

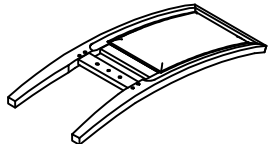

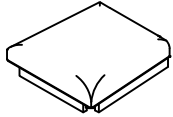

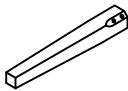
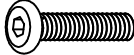

# ASSEMBLY INSTRUCTIONS

## DINING CHAIR

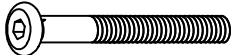
<b>A</b> Chair Back	<b>B</b> Seat Cushion	<b>C</b> Front Leg	<b>D</b> Allen Bolt Ø1/4" x 1 1/2"	<b>E</b> Allen Bolt Ø1/4" x 2"
				
1 pc	1 pc	2 pcs	2 pcs	4 pcs
<b>F</b> Allen Bolt Ø1/4" x 3"	<b>G</b> Lock Washer Ø1/4" x 3/8"	<b>H</b> Flat Washer Ø1/4" x 3/4"	<b>I</b> Allen Key 2 3/8" x 1" x 5/32"	
				
4 pcs	10 pcs	10 pcs	1 pc	

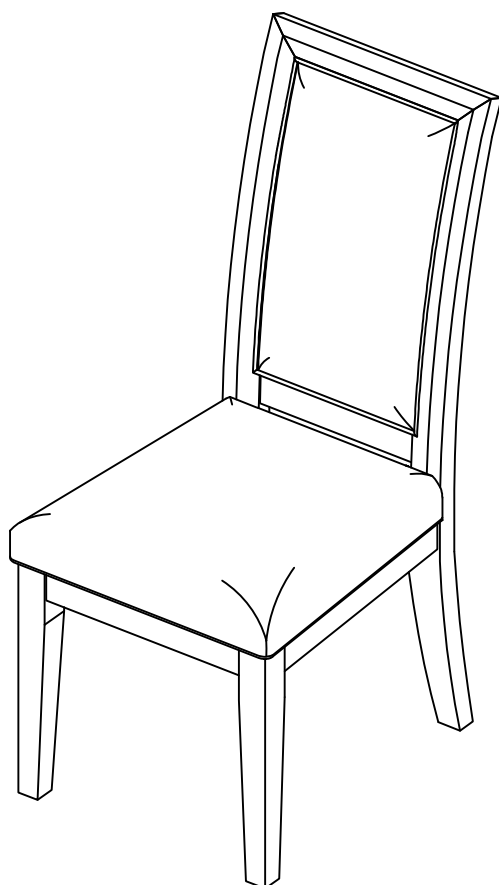

This page lists all the contents included in the box. Please take the time to identify the hardware as well as the individual components to this product. As you unpack and prepare for assembly, place the contents on a carpeted or padded area to protect them from damage.

- 1** Attach the Seat Cushion (B) to the Chair Back (A) using Allen Bolt (D) and Allen Bolt (F), Lock Washer (G) and Flat Washer (H) with the Allen Key (I).

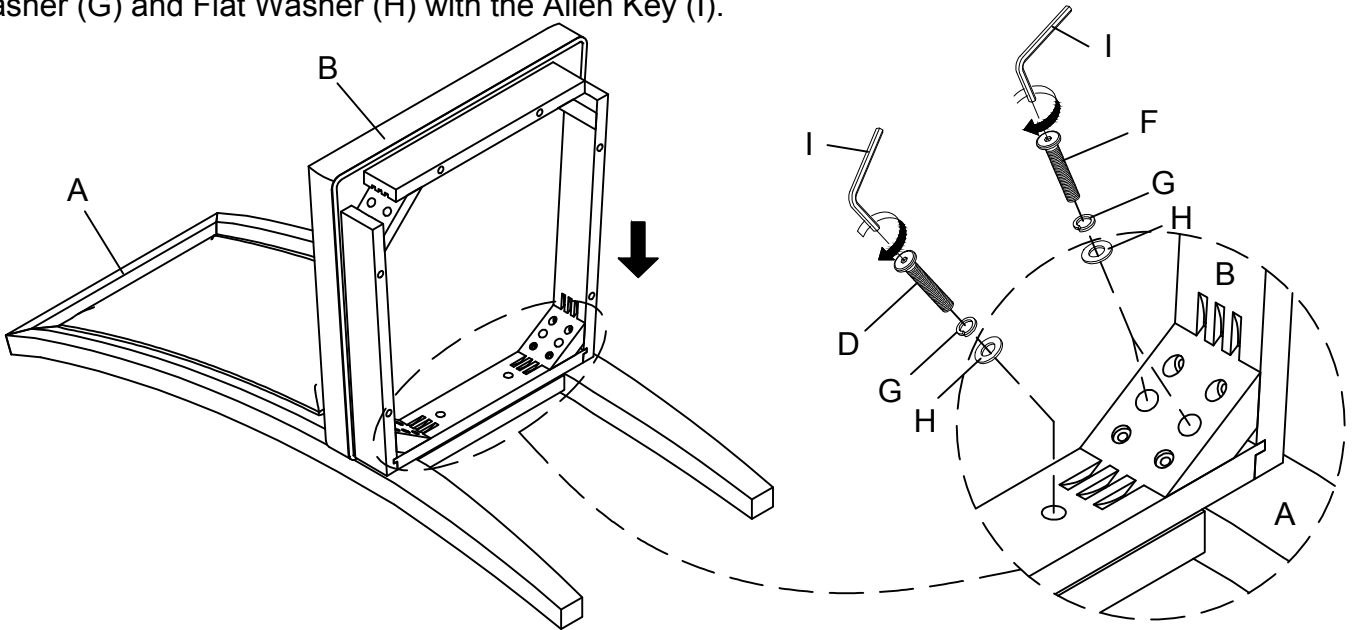

Take the Allen Key and turn the bolts until the legs are secured. **DO NOT TIGHTEN THE BOLTS COMPLETELY.** Stop when you feel you are adding force to tighten the bolt.

- 2** Attach the Front Leg (C) to the Seat Cushion (B) using Allen Bolt (E), Lock Washer (G) and Flat Washer (H) with the Allen Key (I).

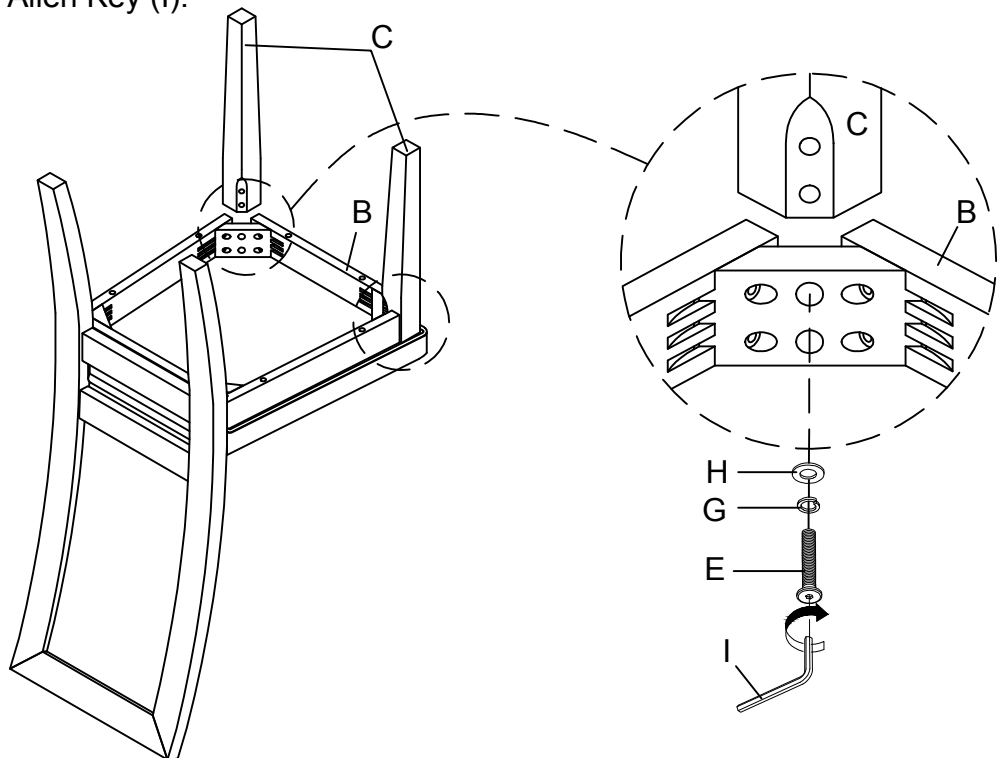

Stand the chair on an even surface and check for balance. If the chair wobbles slightly, apply downward pressure on the uneven leg and tighten the bolts to correct the imbalance. Once the chair is balanced, apply downward pressure evenly in the center of the chair and tighten all bolts, being careful not to over-tighten beyond the hole depth.

Helpful Tip: While tightening the bolts from underneath, have someone sit in the chair.

### Cleaning & Care

Treat surfaces with care. Surfaces are resistant to scratches but are not scratch resistant. Clean surfaces with a dry or damp soft cloth. Do not use abrasive cleaners. Hardware may loosen over time. Periodically check that all connections are tight.