



Ceiling Fan Installation Manual



93089925_C

P2570

Limited Lifetime Warranty

Progress Lighting fan motors are warranted to the original purchaser to be free of electrical and/or mechanical defects for so long as the original purchaser owns the fan. Pull chain switches, reverse switches, capacitors and metal finishes are warranted to be free from defects in materials or workmanship for a period of 1 year from the date of purchase. Warping of wooden or plastic blades is not covered by this warranty nor is corrosion and/or deterioration of any finishes for fans installed within ten miles of any sea coast. Extended warranties for ENERGY STAR® qualified products may apply.

Progress Lighting ceiling fans with built-in LED light sources, when properly installed and under normal conditions of use, are warranted to be free from defects in material and workmanship which cause the light sources to fail to operate in accordance with the specifications for (i) five (5) years from the date of purchase on the LED Light modules and electrical components for fans used in single family residences, and (ii) three (3) years from the date of purchase on the LED Light modules and electrical components for fans used in multi-family or commercial applications. LED bulbs supplied by Progress Lighting carry no warranty other than manufacturer's warranty. Non-LED bulbs carry no warranty.

With proof of purchase, the original purchaser may return the defective fan to the place of purchase during the first 30 days for replacement. After 30 days, the original purchaser MUST contact Progress Lighting at (864) 678-1000 for repair or replacement which shall be determined in Progress Lighting's sole discretion and shall be purchaser's sole and exclusive remedy.

Labor and Shipping Excluded. This warranty does not cover any costs or fees associated with the labor (including, but not limited to, electrician's fees) required to install, remove, or replace a fan or any fan parts.

This warranty shall not apply to any loss or damage resulting from (i) normal wear and tear or alteration, misuse, abuse or neglect, or (ii) improper installation, operation, repair or maintenance by original purchaser or a third party, including without limitation improper voltage supply or power surge, use of improper parts or accessories, unauthorized repair (made or attempted) or failure to provide maintenance to the fan.

THE FOREGOING WARRANTIES STATE PROGRESS LIGHTING'S ENTIRE WARRANTY OBLIGATION AND ORIGINAL PURCHASER'S SOLE AND EXCLUSIVE REMEDY RELATED TO SUCH PRODUCTS. PROGRESS LIGHTING IS NOT RESPONSIBLE FOR DAMAGES (INCLUDING INDIRECT, SPECIAL, INCIDENTAL OR CONSEQUENTIAL), DUE TO PRODUCT FAILURE, WHETHER ARISING OUT OF BREACH OF WARRANTY, BREACH OF CONTRACT, OR OTHERWISE. THIS WARRANTY IS GIVEN IN LIEU OF ALL OTHER WARRANTIES, WHETHER EXPRESSED OR IMPLIED, INCLUDING THOSE OF MERCHANTABILITY, FITNESS FOR A PARTICULAR PURPOSE OR NONINFRINGEMENT.

Some states do not allow limitations on how long an implied warranty lasts or the exclusion or limitations of incidental or consequential damages, so the above limitations and exclusions may not apply to you. This warranty gives you specific rights and you may have other rights which vary from state to state.

Date Purchased _____

Store Purchased _____

Model No. _____ P2570

Serial No. _____

Vendor No. _____ 109226

785247221646

785247221660

UPC 785247221653 _____



Safety Rules.....	1.
Unpacking Your Fan	2.
Installing Your Fan	3.
Operating Your Transmitter	11.
Care of Your Fan	13.
Troubleshooting	14.
Specifications	15.

Table of Contents

1. To reduce the risk of electric shock, insure electricity has been turned off at the circuit breaker or fuse box before beginning.
2. All wiring must be in accordance with the National Electrical Code and local electrical codes. Electrical installation should be performed by a qualified licensed electrician.
3. **WARNING:** To reduce the risk of electrical shock and fire, do not use this fan with any solid-state fan speed control device.
4. **WARNING:** To reduce the risk of fire, electric shock, or personal injury, mount to outlet box marked "Acceptable for Fan Support of 15.9 kg (35 lbs.) Or Less" and use mounting screws provided with the outlet box. Most outlet boxes commonly used for the support of light fixtures are not acceptable for fan support and may need to be replaced. Due to the complexity of the installation of this fan, a qualified licensed electrician is strongly recommended.
9. To avoid personal injury or damage to the fan and other items, be cautious when working around or cleaning the fan.
10. Do not use water or detergents when cleaning the fan or fan blades. A dry dust cloth or lightly dampened cloth will be suitable for most cleaning.
11. After making electrical connections, spliced conductors should be turned upward and pushed carefully up into the outlet box. The wires should be spread apart with the grounded conductor and the equipment-grounding conductor on one side of the outlet box.
12. Electrical diagrams are for reference only. Light kits that are not packed with the fan must be UL Listed and marked suitable for use with the model fan you are installing. Switches must be UL General Use Switches. Refer to the Instructions packaged with the light kits

WARNING

TO REDUCE THE RISK OF FIRE, ELECTRIC SHOCK OR PERSONAL INJURY, MOUNT FAN TO OUTLET BOX MARKED ACCEPTABLE FOR FAN SUPPORT.

WARNING

TO REDUCE THE RISK OF PERSONAL INJURY, DO NOT BEND THE BLADE ARMS (ALSO REFERRED TO AS BRACKETS) DURING ASSEMBLY OR AFTER INSTALLATION. DO NOT INSERT OBJECTS IN THE PATH OF THE BLADES.

5. The outlet box and support structure must be securely mounted and capable of reliably supporting a minimum of 35 lbs (15.9 kg) or less. Use only UL-listed outlet boxes marked **FOR FAN SUPPORT**.
6. The fan must be mounted with a minimum of 7 ft (2.1m) clearance from the trailing edge of the blades to the floor.
7. To operate the reverse function on this fan, press the reversing button while the fan is running.
8. Avoid placing objects in the path of the blades.

NOTE

READ AND SAVE ALL INSTRUCTIONS!

1. Safety Rules

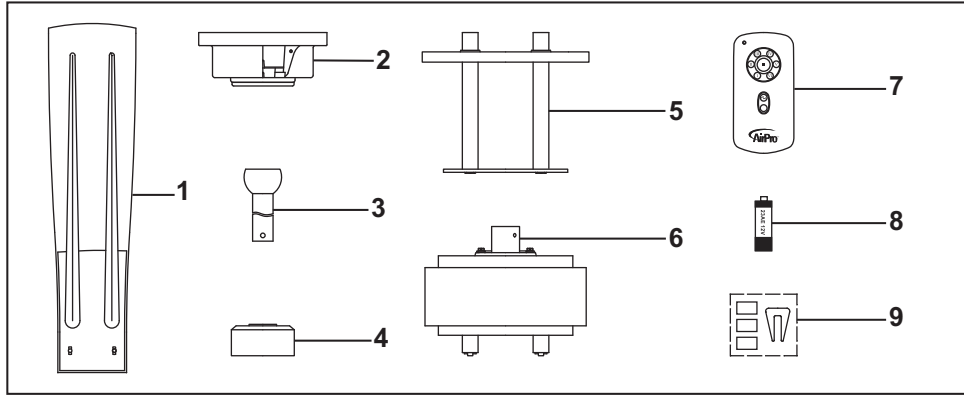

Unpack your fan and check the contents. You should have the following items:

- | | |
|--------------------------|-------------------------|
| 1. Fan blades (4) | 6. Fan motor assembly |
| 2. Canopy assembly | 7. Remote control |
| 3. Ball/downrod assembly | 8. 12V MN21/A23 battery |
| 4. Coupling cover | 9. Balancing kit |
| 5. Decorative scroll | |

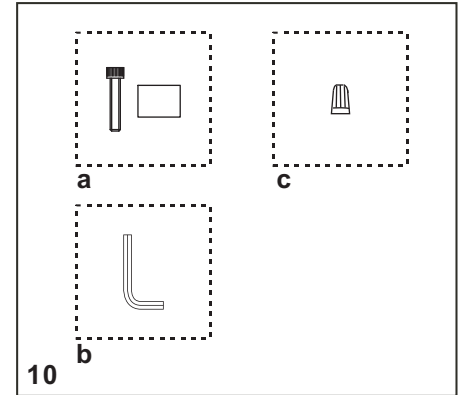

10. Loose parts bag containing:

- a. Blade attachment hardware**
(4 screws, 4 metal washers)
- b. Allen wrench**
- c. Mounting hardware**
Wire nuts (3)

Unpacking Your Fan 2.

Tools Required

Phillips screw driver, straight slot screw driver, adjustable wrench, step ladder, and wire cutters.

Mounting Options

If there isn't an existing UL listed mounting box, then read the following instructions. Disconnect the power by removing fuses or turning off circuit breakers.

Secure the outlet box directly to the building structure. Use appropriate fasteners and building materials. The outlet box and its support must be able to fully support the moving weight of the fan (at least 35 lbs). Do not use plastic outlet boxes.

WARNING

TO REDUCE THE RISK OF FIRE, ELECTRIC SHOCK, OR OTHER PERSONAL INJURY, MOUNT FAN ONLY TO AN OUTLET BOX MARKED ACCEPTABLE FOR FAN SUPPORT AND USE THE MOUNTING SCREWS PROVIDED WITH THE OUTLET BOX. OUTLET BOXES COMMONLY USED FOR THE SUPPORT OF LIGHTING FIXTURES MAY NOT BE ACCEPTABLE FOR FAN SUPPORT AND MAY NEED TO BE REPLACED. CONSULT A QUALIFIED ELECTRICIAN IF IN DOUBT.

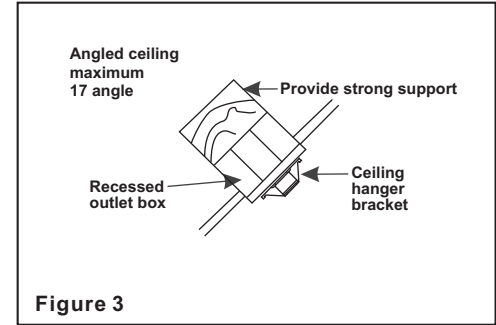
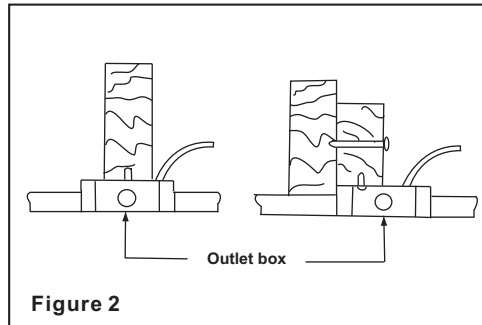
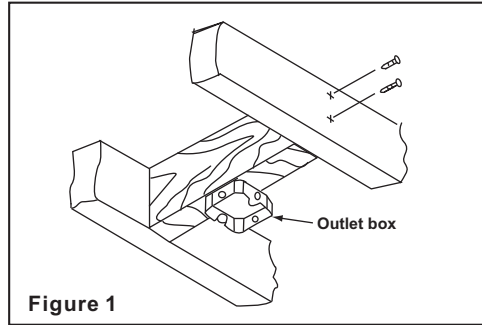

Note: You may need a longer downrod to maintain proper blade clearance when installing on a steep, sloped ceiling.

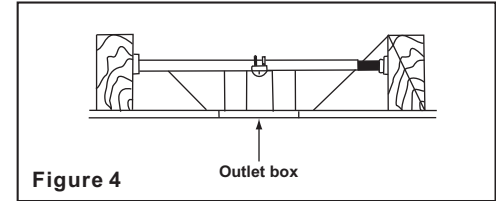

To hang your fan where there is an existing fixture but no ceiling joist, you may need an installation hanger bar as shown in Figure 4 (available at your Progress Lighting Retailer).

3. Installing Your Fan

Hanging the Fan

REMEMBER to turn off the power. Follow the steps below to hang your fan properly.

NOTE: This ceiling fan is supplied with two types of hanging assemblies; the standard ceiling installation using the downrod with ball and socket mounting, and the "close-to-ceiling" mounting. The "close-to-ceiling" mounting is recommended in rooms with less than 8-foot ceilings or in areas where additional space is desired from the floor to the fan blades.

When using the standard downrod installation, the distance from the ceiling to the bottom of the fan blades will be approximately 18 1/8 inches. The "close-to-ceiling" installation reduces the distance from the ceiling to the bottom of the fan blades to approximately 9 inches.

Once you have decided which ceiling installation you will use, proceed with the following instructions. Where necessary, each section of the instructions will note the different procedures to follow for the two types of installation.

Option 1: Standard Ceiling Mounting

1. Remove the canopy ring from the canopy. (Figure 5)

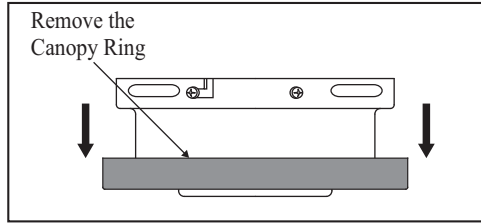

Figure 5

2. Remove the mounting bracket from the canopy by loosening the four screws on the top of the canopy. Remove the two non-slotted screws and loosen the slotted screws. (Figure 6)

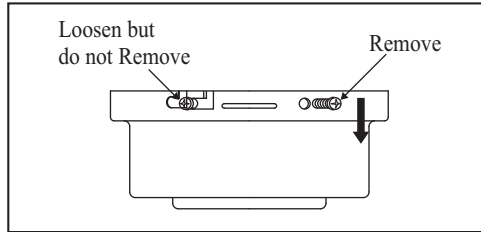

Figure 6

3. Route wires exiting from the top of the fan motor through the coupling cover, decorative scroll, canopy cover, canopy ring, canopy and then through the ball/ downrod. (Figure 7)
4. Loosen, but do not remove the 2 set screws on the collar on top of the motor housing.

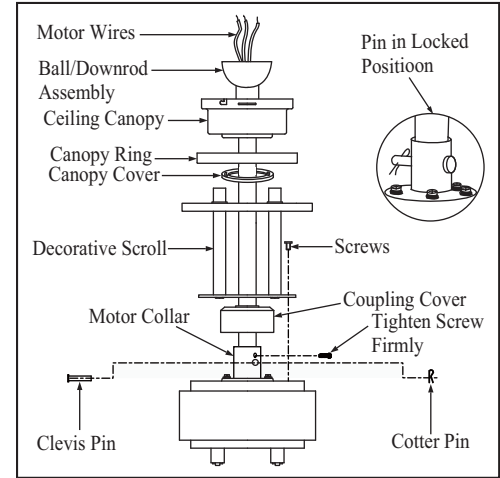

Figure 7

5. Align the holes at the bottom of the downrod with the holes in the coupling on top of the motor housing. (Figure 7) Carefully insert the clevis pin through the holes in the collar and downrod. Be careful not to jam the clevis pin against the wiring inside the downrod. Insert the cotter pin through the hole near the end of the clevis pin until it snaps into its locked position, as noted in the circle inset of Fig. 7.
6. Tighten two set screws on top of the fan motor firmly. Attaching the decorative scroll to the motor housing using the screws provided. (Figure 7)

WARNING
FAILURE TO PROPERLY INSTALL
CLEVIS PIN AS NOTED IN STEP 5
COULD RESULT IN FAN LOOSENING
AND POSSIBLY FALLING.

NOTE: If a longer downrod is needed, take out the screw located in the hanger ball, lower the hanger ball and remove the pin, remove all 3 pieces from the downrod and assemble them onto the new longer downrod before proceeding step 3. (The longer downrod is available at any Progress Lighting retailer)

Option 2: Close-to-Ceiling Mounting

1. Remove the canopy ring from the canopy. (Figure 5)
2. Remove the mounting bracket from the canopy by loosening the four screws on the top of the canopy. Remove the two non-slotted screws and loosen the slotted screws. (Figure 6)
3. Remove the decorative canopy bottom cover from the canopy by turning the canopy bottom cover counterclockwise. (Figure 8)

5.

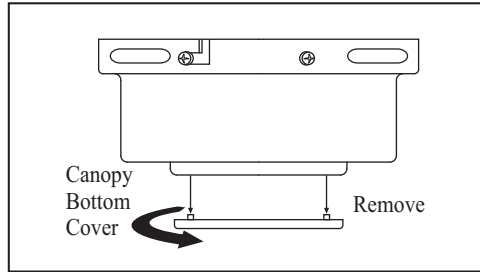

Figure 8

4. Remove three of the six screws and lock washers (every other one) from the collar of top motor. (Figure 9)
5. Route the wires exiting the top of the fan motor through the canopy ring (make sure the slot openings are on top), then proceed to place the ceiling canopy over the collar at the top of the motor. (Figure 10)
6. Align the mounting holes with the holes in the motor and fasten using the screws and lock washers removed in step 4. (Fig. 10)
7. Tighten the mounting screws security.

WARNING
FAILURE TO COMPLETELY TIGHTEN
THE THREE SCREWS IN STEP 7 COULD
RESULT IN FAN LOOSENING AND
POSSIBLY FALLING.

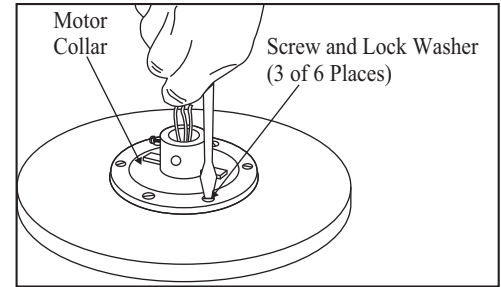

Figure 9

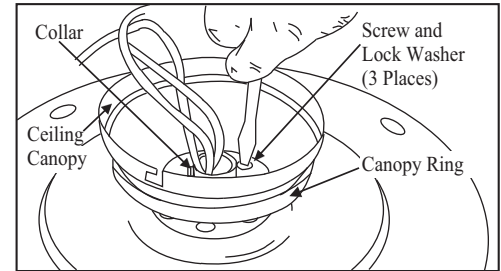

Figure 10

Installing Fan to the Electrical Box

WARNING

TO REDUCE THE RISK OF FIRE, ELECTRIC SHOCK OR OTHER PERSONAL INJURY. MOUNT FAN ONLY TO AN OUTLET BOX OR SUPPORTING SYSTEM MARKED ACCEPTABLE FOR FAN SUPPORT AND USE THE MOUNTING SCREWS PROVIDED WITH THE OUTLET BOX.

1. Pass the 120-volt supply wires through the center hole in the mounting bracket. (Figure 11)
2. Attach the mounting bracket on the outlet box by sliding the mounting bracket over the screws provided with the outlet box. (Figure 11) When using “close-to-ceiling” mounting, it is important that the mounting bracket be level. If necessary, use leveling washers (not included) between the mounting bracket and the outlet box. Note that the flat side of the mounting bracket is toward the outlet box. (Figure 11)
3. Securely tighten the two mounting screws.

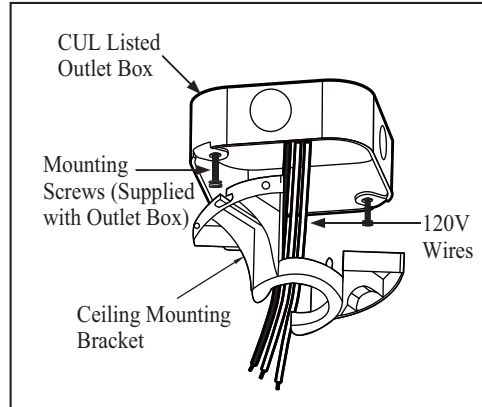

Figure 11

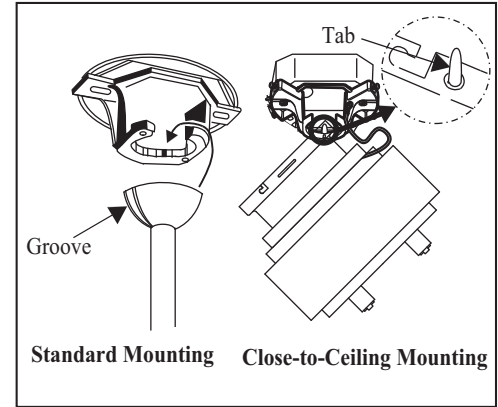

Figure 12

4. Carefully lift the fan assembly up to the ceiling mounting bracket and hang the fan on the tab provided by utilizing one of the holes at the outer rim of the ceiling canopy. (Figure 12) If using standard mounting, seat the hanger ball in the mounting bracket socket. Make sure the tab on the mounting bracket socket is properly seated in the groove in the hanger ball. (Figure 12)

WARNING

THE TAB AS SHOWN IN FIGURE 12 IS ONLY TO BALANCE THE FAN WHILE ATTACHING WIRING. FAILURE TO HANG AS SHOWN IN FIGURE 12 MAY RESULT IN TAB BREAKING CAUSING THE FAN TO FALL. TAB MUST PASS FROM INSIDE TO OUTSIDE OF CANOPY.

WARNING

WHEN USING THE STANDARD BALL/DOWNROD MOUNTING. THE TAB IN THE RING MUST REST IN THE GROOVE OF THE HANGER BALL. FAILURE TO PROPERLY SEAT THE TAB IN THE GROOVE COULD CAUSE DAMAGE TO WIRING.

Make the Electric Connections

WARNING: To avoid possible electrical shock, be sure electricity is turned off at the main fuse box before wiring.

Step 1. Motor to House Supply Wires Electrical Connections: Connect the WHITE wire (Neutral) from the outlet box to the WHITE wire marked "AC in N" from the motor. (Fig. 13)

Step 2. Connect the BLACK wire (Hot) from the outlet box to the BLACK wire marked "AC in L" from the motor. (Fig. 13)

Secure all wire connections with the plastic wire nuts provided.

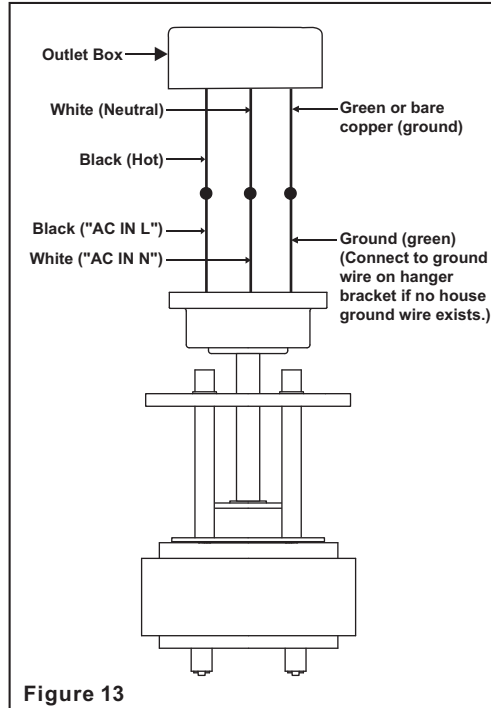

Finishing the Fan Installation

Standard Ceiling Mounting

WARNING
LOCKING SLOTS OF CEILING CANOPY ARE PROVIDED ONLY AS AN AID TO MOUNTING. DO NOT LEAVE FAN ASSEMBLY UNATTENDED UNTIL ALL FOUR CANOPY SCREWS ARE ENGAGED AND FIRMLY TIGHTENED.

Slide canopy up to the ceiling as shown in Figure 14. Make sure you place the wires safely into the outlet box. Secure the canopy to the hanger bracket with the four screws with your fan. Raise up canopy ring and line up the 4 tabs with the 4 grooves on the canopy. Once lined up, slide the canopy ring and secure it to the canopy until snug.

WARNING
MAKE SURE THE TAB ON THE HANGING BRACKET PROPERLY SITS IN THE GROOVE IN THE HANGER BALL BEFORE ATTACHING THE CANOPY TO THE BRACKET BY TURNING THE HOUSING UNTIL IT DROPS INTO PLACE.

Close-to-Ceiling Mounting

Remove the fan from the tab on the hanger bracket. Secure the canopy to the hanger bracket with four screws included with your fan. (Fig. 15) Raise up canopy ring and line up the 4 tabs with the 4 grooves on the canopy. Once lined up, slide the canopy ring and secure it to the canopy until snug.

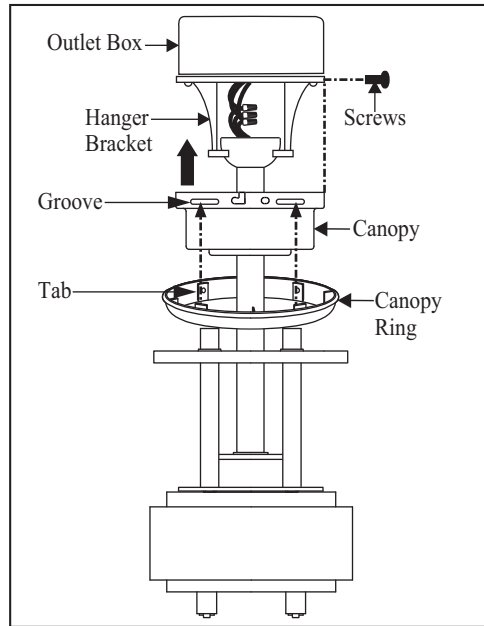

Figure 14

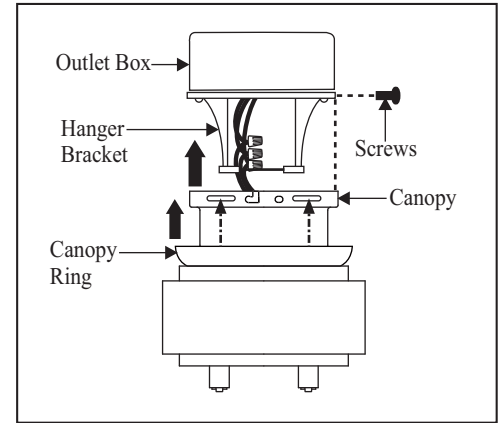
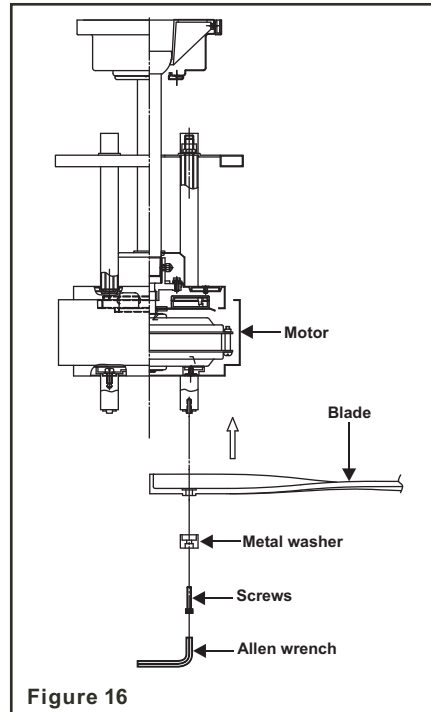

Figure 15

Attaching the Fan Blades

Step 1. Align the holes from the blade to the holes from the motor, and secure the blade in place by using the screws and metal washers with the allen wrench provided. (Fig. 16)

Step 2. Repeat this process to attach the other blades. (Fig. 16)



Blade Balancing

All blades are grouped by weight. Because natural woods vary in density, the fan may wobble even though the blades are weighed equally.

The following procedure should correct most fan wobbling problems. Check after each step.

1. Check that all blade and blade arm screws are secure.
2. Most fan wobbling problems are caused when blade levels are unequal. Check this level by selecting a point on the ceiling above the tip of one of the blades. Measure this distance as shown in Figure 17. Rotate the fan until the next blade is positioned for measurement. Repeat for each blade. The distance deviation should be equal within 1/8".
3. Use the enclosed Blade Balancing Kit if the blade wobble is still noticeable.
4. If the blade wobble is still noticeable, interchanging two adjacent (side by side) blades can redistribute the weight and possibly result in smoother operation.

WARNING
TO REDUCE THE RISK OF PERSONAL INJURY, DO NOT BEND THE BLADE HOLDERS WHILE INSTALLING, BALANCING THE BLADES, OR CLEANING THE FAN. DO NOT INSERT FOREIGN OBJECTS BETWEEN ROTATING FAN BLADES.

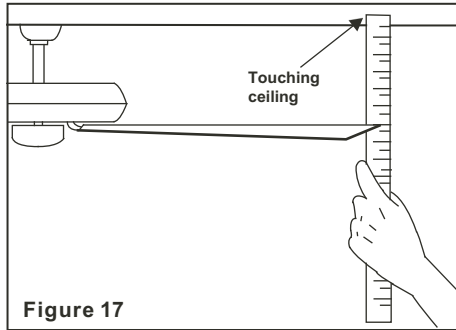

Figure 17

Installing the battery

Install a 12V MN21/A23 battery (included) into the remote control. To prevent damage to the remote control, remove the battery if not used for long periods. (Fig. 18)

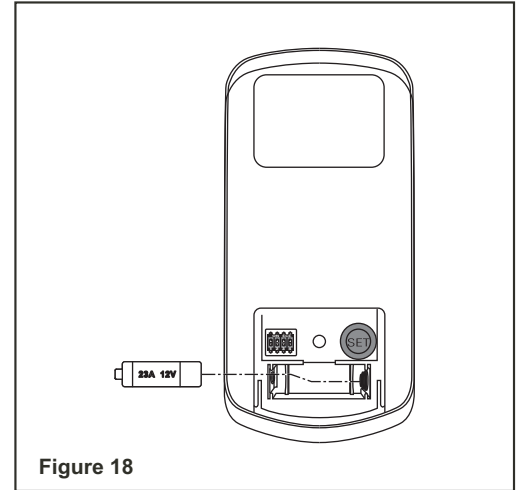

Figure 18

Remote Control Button Definitions:

These six buttons are used to set the fan speed as follows:

I = minimum speed

II = low speed

III = medium low speed

IV = medium speed

V = medium high speed

VI = high speed

■ button: Turns the fan off.

⊗ button: Controls fan direction.

Your DC brushless motor is equipped with an automatically learned type remote control. There are no frequency switches on the receiver; the receiver unit will automatically scan the frequency from the remote control if any changes are made. The frequency settings on the transmitter should be changed **ONLY in case of interference or if a second or more ceiling fans with the same type of control system are installed in the same structure.**

Setting the Remote Control

Follow the below steps to set the remote control:

The auto learning function will only mandate within 60 seconds when turning the fan's AC power ON.

a) Select desired frequency from the transmitter. The dip switches can be set to 16 different combinations. (Fig. 20)

b) From the back of the transmitter, with the fan's power off, restore power to the fan. Press and hold "SET" button for about 5 seconds and release. If optional light kit is installed, the light kit will flash twice and the signal light on the hand held transmitter will come on when the button is pressed. The fan has completed the pairing process with the remote control and is ready for use. (Fig. 20)

NOTE: If the self calibration test failed, turn the AC power off; restore power and process the self calibration test again.

NOTE: During self calibration test, the remote is non-functional.

NOTE: The learning frequency function and self calibration test will continue to retain the last set frequency and calibration set even when the AC power is shut off. If the frequency is changed the self calibration test will occur again.

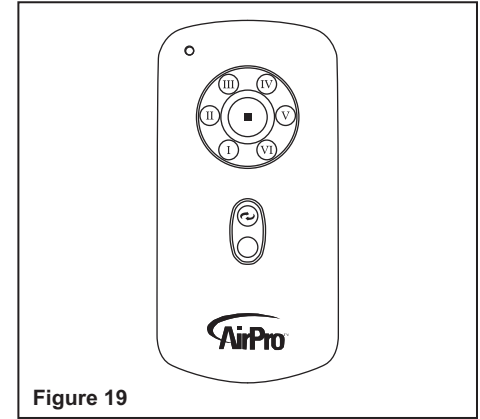

Figure 19

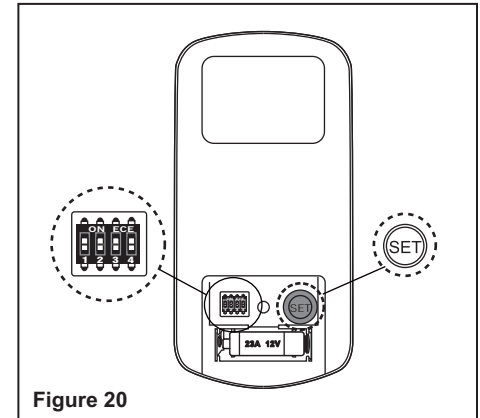

Figure 20

11. Operating Your Transmitter

This receiver provides the following protective function:

1. Lock Rotor Position: The DC motor has a built-in safety against a stalled or locked rotor condition (stalled blade rotation). If there is an obstruction or fault with the motor, the current monitoring function will automatically turn power off to the motor after 30 seconds. Remove the obstruction and turn the AC power off. Restore power and re-start fan motor.

2. Over 80W protection: When the receiver detects motor power consumption which is greater than 80W, the receiver power will be stopped and operation will immediately discontinue. Wait for 5 seconds and then turn the receiver power back on.

Speed settings for warm or cool weather depend on factors such as the room size. Ceiling height, number of fans and so on.

NOTE: To operate the reverse function on this fan, press the reverse button while the fan is running.

Warm weather - (Forward) A downward airflow creates a cooling effect as shown in Fig. 21. This allows you to set your air conditioner on a warmer setting without affecting your comfort.

Cool weather - (Reverse) An upward airflow moves warm air off the ceiling area as shown in Fig. 22. This allows you to set your heating unit on a cooler setting without affecting your comfort.

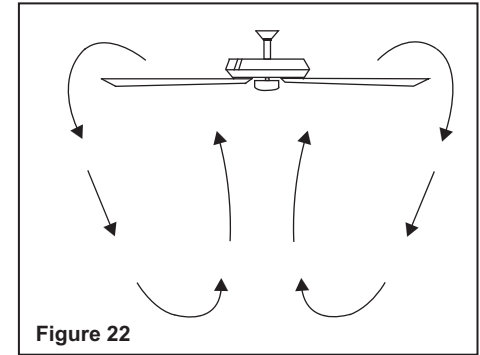
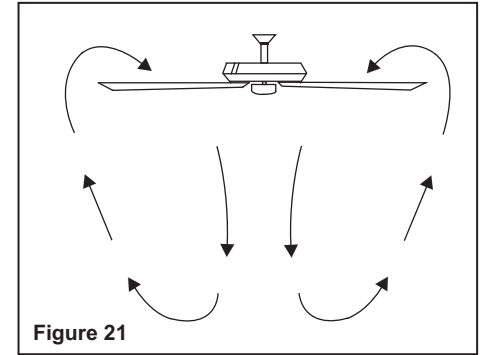

Here are some suggestions to help you maintain your fan

1. Because of the fan's natural movement, some connections may become loose. **Check the support connections, brackets, and blade attachments twice a year.** Make sure they are secure. **(It is not necessary to remove fan from ceiling.)**

2. Clean your fan periodically to help maintain its new appearance over the years. Use only a soft brush or lint-free cloth to avoid scratching the finish. The plating is sealed with a lacquer to minimize discoloration or tarnishing. Do not use water when cleaning. This could damage the motor, or the wood, or possibly cause an electrical shock.

3. You can apply a light coat of furniture polish to the wood blades for additional protection and enhanced beauty. Cover small scratches with a light application of shoe polish.

4. **There is no need to oil your fan.** The motor has permanently lubricated bearings.

IMPORTANT
MAKE SURE THE POWER IS OFF AT THE
ELECTRICAL PANEL BOX BEFORE YOU
ATTEMPT ANY REPAIRS. REFER TO THE
SECTION "MAKING ELECTRICAL
CONNECTIONS"

13. Care of Your Fan

Problem

Solution

Fan will not start.

1. Check circuit fuses or breakers.
2. Check line wire connections to the fan and switch wire connections in the switch housing.
CAUTION: Make sure main power is off.
3. Check to make sure the dip switches from the transmitter and receiver are set to the same frequency.

Fan sounds noisy.

1. Make sure all motor housing screws are snug.
2. Make sure the screws that attach the fan blade bracket to the motor hub is tight.
3. Make sure wire nut connections are not rubbing against each other or the interior wall of the switch housing.
CAUTION: Make sure main power is off.
4. Allow a 24-hour "breaking-in" period. Most noise associated with a new fan disappear during this time.
5. If using an optional light kit, make sure the screws securing the glassware are tight. Check that light bulb is also secure.
6. Some fan motors are sensitive to signals from solid-state variable speed controls. If you have installed this type of control, choose and install another type of control.
7. Make sure the upper canopy is a short distance from the ceiling. It should not touch the ceiling.

Remote control malfunction

1. Do not connect the fan with wall mounted variable speed control (s).
2. Make sure the dip switches are set correctly.

Troubleshooting 14.

Fan Size	Speed	Volts	Amps	Watts	RPM	CFM	N.W.	G.W.	C.F.
56"	Low	120	0.046	2.08	53	1951.56	17.41 lbs	19.84 lbs	2.10'
	High	120	0.43	32.67	159	6767.71			

These are approximate measures. They do not include Amps and Wattage used by the light kit.

This device complies with part 15 of the FCC Rules. Operation is subject to the following two conditions: (1) This device may not cause harmful interference, and (2) this device must accept any interference received, including interference that may cause undesired operation.

Warning: Changes or modifications to this unit not expressly approved by the party responsible for compliance could void the user's authority to operate the equipment.

NOTE: This equipment has been tested and found to comply with the limits for a Class B digital device, pursuant to Part 15 of the FCC Rules. These limits are designed to provide reasonable protection against harmful interference in a residential installation. This equipment generates, uses and can radiate radio frequency energy and, if not installed and used in accordance with the instructions, may cause harmful interference to radio communications.

However, there is no guarantee that interference will not occur in a particular installation. If this equipment does cause harmful interference to radio or television reception, which can be determined by turning the equipment off and on, the user is encouraged to try to correct the interference by one or more of the following measures:

- Reorient or relocate the receiving antenna.
- Increase the separation between the equipment and receiver.
- Connect the equipment into an outlet on a circuit different from that to which the receiver is connected.
- Consult the dealer or an experienced radio/TV technician for help.

15. Specifications

©2020 Progress Lighting, Inc.
701 Millennium Blvd.,
Greenville, SC 29607
All Rights Reserved