

# BLACK DIAMOND®

## Chest Freezer Instruction Manual



**BDCF-5**  
5.4 cu. ft.



**BDCF-9R**  
8.1 cu. ft.



**BDCF-10R**  
10 cu. ft.



**BDCF-13R**  
12.2 cu. ft.



**BDCF-16/2R**  
15.4 cu. ft.

**This manual contains important information regarding your unit. Please read this manual thoroughly prior to equipment set-up, operation, and maintenance. Failure to comply with regular maintenance guidelines outlined in this manual may void the warranty.**

## IMPORTANT SAFEGUARDS

Please pay close attention to the safety notices in this section. Disregarding these notices may lead to serious injury and/or damage to the unit.



**WARNING**

### DANGER:

- Risk of fire or explosion.
- Flammable refrigerant R290 used.
- To be repaired only by trained service personnel.
- **DO NOT** use mechanical devices to defrost refrigerator.
- **DO NOT** puncture refrigerant tubing.
- **DO NOT** pierce or burn.
- **DO NOT** store in a room with continuously operating ignition sources (for example: open flames, an operating gas appliance or an operating electric heater).

## ATTENTION

- This appliance is not intended for use by persons (including children) with reduced physical, sensory or mental capabilities, or lack of experience and knowledge, unless they have been given supervision or instruction concerning use of the appliance by a person responsible for their safety.
- **DO NOT** allow children to play with unit.
- **DO NOT** leave children unattended with unit, adult supervision required.
- **NEVER** sit in the drawers or hang from the door.
- **DO NOT** use this unit for anything other than intended use.
- **DO NOT** overload outlet, to minimize shock and fire hazards.
- **DO NOT** spray the unit with water.
- **DO NOT** attempt to remove or repair any component.
- **DO NOT** attempt to alter or tamper with the electrical cord.
- If the supply cord is damaged, it must be replaced by the manufacturer or its service agent or a similarly qualified person in order to avoid a hazard.
- **DO NOT** rest unit on or against the electrical cord or plug.
- **DO NOT** defrost the appliance with other electrical devices (i.e. hair dryer) or any artificial means and do not use sharp metal objects to remove the ice on the freezer, as this could cause damage to the refrigerant system.
- **DO NOT** operate any electrical appliances inside the refrigerator or freezer.
- **WARNING:** Do not place bottles (glass or plastic) containing liquids (especially effervescent liquids) into the freezer as they could cause the bottle to burst during freezing.
- **WARNING:** Do not store explosive substances such as aerosol cans with a flammable propellant in this appliance.
- **DO NOT** damage the refrigerant circuit.
  - \* In the event that the refrigerant circuit is damaged, avoid open flames or ignition sources and ventilate the room in which the unit is placed – **DO NOT** use the appliance until you have been advised to do so by a service engineer.
- **DO NOT** store any flammable and explosive gas or liquids inside the unit.
- The appliance shall be stored in a well-ventilated area where the room size corresponds to the room area as specified for operation.
- The appliance shall be stored so as to prevent mechanical damage from occurring.
- **WARNING:** Keep ventilation openings, in the appliance enclosure or in the built-in structure, clear of obstruction.
- **DO NOT** touch the cooling surfaces while the appliance operates, especially with wet hands, because the skin may stick to cold surfaces.
- **DO NOT** eat ice which has just been removed from the freezer as this can cause freezer burns to the hands and tongue.

# BLACK◆DIAMOND®

## TRANSPORTATION AND PLACEMENT

- **WARNING:** When positioning the appliance ensure the supply cord is not trapped or damaged.
- **WARNING: DO NOT** place extension sockets or charging transformers/power supplies adjacent to the compressor as they could overheat.
- Install and level the unit on a floor able to take its weight and in a place suitable for its size and use.
- Insert the plug into a socket which is appropriate. This appliance has a plug already fitted – if the plug is not suitable for your socket we suggest that you call an authorized electrician for assistance. If the plug is damaged in any way – do not attempt to use it. It must be replaced with a new plug.
- Do not install the appliance in direct sunlight and close to heat sources. Do not allow the appliance to be exposed to rain.
- Choose a well ventilated area. There should be at least 4" (10 cm) of open space along the sides, top, and back of the freezer.
- Before switching on place the appliance in an upright position and wait at least three hours without moving the appliance. This will give the refrigerant circuit time to settle and operate efficiently.
- Install the appliance in a dry and well-ventilated place. The appliance is for use in places within the temperature ranges defined according to the climatic class given on the Data Label located on the back of the product. The appliance may not operate consistently if it is sited for extended periods of time below the cold end of the climate class temperature range for which the appliance is designed.
- If the appliance is installed next to another refrigerator or freezer, observe the minimum distance of 4" (10 cm) to avoid condensation.
- The manufacturer is not responsible for failure to complete installation as described in this guide.

## PROPER GROUNDING REQUIRED

- To minimize shock and fire hazards, make sure that the unit is properly grounded.

## POWER SOURCE

- **DO NOT** plug or unplug the cord with wet hands, to minimize shock and fire hazards
- **DO NOT** plug this appliance into an extension lead.
- **DO NOT** use old or damaged power supply cables.
- **DO NOT** twist, bend or trap the cable. Cables should also be kept clear of heat sources.
- **UNPLUG UNIT BEFORE** maintenance and cleaning.
- When the unit will not be in use for a long period of time, disconnect the power first, then clean it.
- Avoid turning on and off the power too frequently.
- After unplugging the unit, wait at least 5 minutes before re-plugging it. Failure to do so could cause damage to the compressor.
- Specified capacity of the wire is 6A. Section squares of the wire is 0.75 mm<sup>2</sup>. Single line or compound lines are all allowed. The fuse of 2.5A specified electric current should be installed.
- If damaged, power cord should be replaced with the same of 6A and 0.75 mm<sup>2</sup>.
- Single-phase power supply, 50Hz, voltage range 187~242V. If the voltage is unstable, install a voltage stabilizer with capacity above 1000W.

## DISPOSAL

- **DO NOT** dispose of this appliance with household waste.
- Dispose of properly in accordance with Federal or local regulations.
- Your old appliances contain insulation gases and refrigerant that must be disposed of properly.
- Refer to local regulations regarding disposal of the appliance for its flammable gas.
- Before you scrap the appliance, please take off the doors to prevent children from being trapped.
- If this appliance is to replace an old one equipped with a lock, break or remove the lock as a safety measure to avoid children becoming trapped inside.
- Before carrying out decommissioning procedure, it is essential that the technician is completely familiar with the equipment and all its detail. It is recommended good practice that all refrigerants are recovered safely. Prior to the task being carried out, an oil and refrigerant sample shall be taken in case analysis is required prior to re-use of recovered refrigerant. It is essential that electrical power is available before the task is commenced.
- When removing refrigerant from a system, either for servicing or decommissioning, it is recommended

# BLACK◆DIAMOND®

good practice that all refrigerants are removed safely. The recovery equipment shall be in good working order with a set of instructions concerning the equipment that is at hand and shall be suitable for the recovery of all appropriate refrigerants including, when applicable, FLAMMABLE REFRIGERANTS. The recovered refrigerant shall be returned to the refrigerant supplier in the correct recovery cylinder, and the relevant waste transfer note arranged. Do not mix refrigerants in recovery units and especially not in cylinders.

## INSTALLATION WARNINGS:

- The appliance shall be installed in accordance with national wiring regulations
- The appliance is to be installed in accordance with the Safety Standard for Refrigeration Systems, ANSI/ASHRAE 15.

## Notice:

- \* Any person who is involved with working on or breaking into a refrigerant circuit should hold a current valid certificate from an industry-accredited assessment authority, which authorizes their competence to handle refrigerants safely in accordance with an industry recognized assessment specification.
- \* Servicing shall only be performed as recommended by the equipment manufacturer. Maintenance and repair requiring the assistance of other skilled personnel shall be carried out under the supervision of the person competent in the use of flammable refrigerants.
- \* Component parts shall be replaced with like components so as to minimize the risk of possible ignition due to incorrect parts.

## INSTALLATION:

1. Unpack and remove all packaging before using the freezer.
2. Don't tip over the freezer more than 45° while moving it.
3. Install in a cool, dry environment with good ventilation, and without corrosive gas.
4. Do not install unit close to heat sources or directly under the sunlight.
5. Allow 4" (10 cm) of space between the wall and the front and the back of the unit.
6. Place on a clean, level surface.
7. Allow freezer to come to temperature before storing food inside.

## PANEL FUNCTIONS

- The unit has one control for regulating the temperature. The temperature control is located on the lower right-hand corner.
- The first time you turn the unit on, turn the temperature control knob in a clockwise direction to the maximum setting "7" and run for at least 2 hours before putting frozen foods inside. This will ensure the cabinet is thoroughly chilled before food is put in.
- The range of the temperature control is from position "1", the warmest, to "7", the coldest. Adjust the temperature control to the setting that best suits your needs. The setting of "4" should be correct for home or office refrigerator use.
- To turn the refrigerator off, turn the temperature control to "0"
- Red light: Power on

## NOTE:

- Turning the temperature control to the "0" position stops the cooling cycle but does not shut off the power to the refrigerator.
- If the unit is unplugged, loses power, or is turned off, you must wait 3 to 5 minutes before restarting the unit. If you attempt to restart before this time delay, the refrigerator will not start.
- Large amounts of food will lower the cooling efficiency of the appliance.
- If you choose to change the thermostat setting, adjust the thermostat control by one numerical increment at a time. Allow several hours for the temperature to stabilize between adjustments.
- \* There are different configurations. Please refer to your own appliance's appearance.

# BLACK DIAMOND®

## PARTS OF THE UNIT



NO.	PART
1	Handle*
2	Door*
3	Basket

NO.	PART
4	Grill Cover
5	Control Panel
6	Wheel

\* There are different configurations. Please refer to your own appliance's appearance.

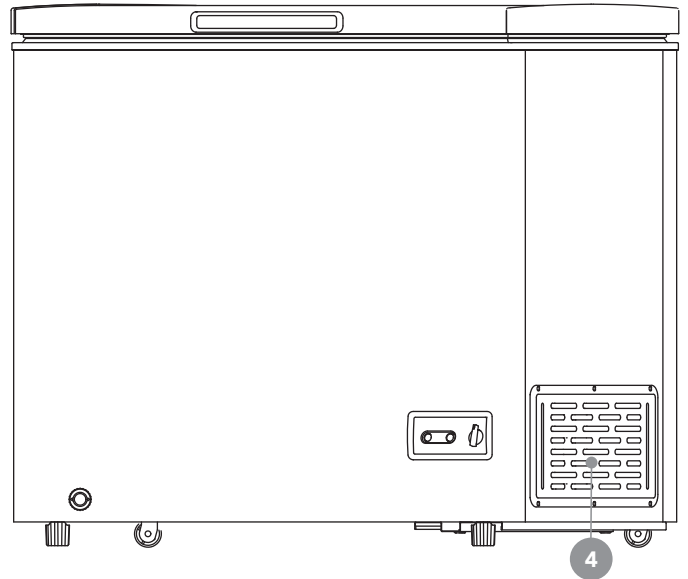

## TEMPERATURE ADJUSTMENT/OPERATION

The temperature of the appliance is controlled by setting the thermostat dial on the front of the cabinet.

- The number 1 indicates the warmest setting.
- The number 7 indicates the coldest setting.
- The number 4 setting should be sufficient for regular home use.
- The temperature range of the appliance is approximately  $-12 \sim -24^{\circ}\text{C}$  ( $10.4 \sim -11.2^{\circ}\text{F}$ ).
- To stop the cooling function, turn the dial to the "0" position.

### Important:

- The temperature inside the appliance can vary based on ambient room temperature, the frequency that the lid is opened and the amount of fresh food that has recently been added to the appliance.
- **Do not** overload the appliance as this can affect performance.
- **Do not** freeze large quantities of fresh food at the same time.

Control Panel

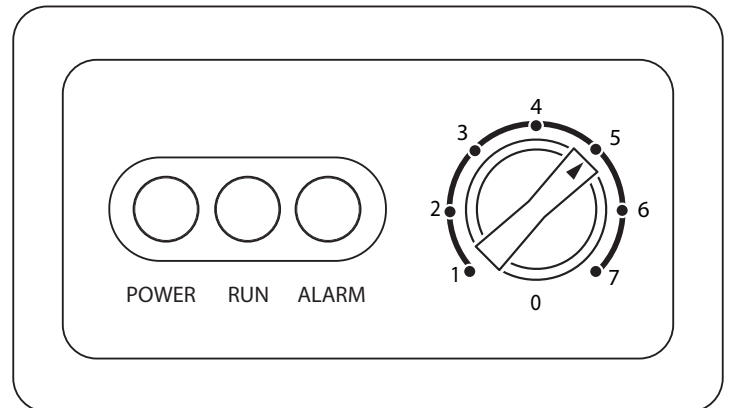

# BLACK DIAMOND®

ONLY FOR BDCF-10R, BDCF-13R, BDCF-16/2R UNITS:

## Latch Hook Installation

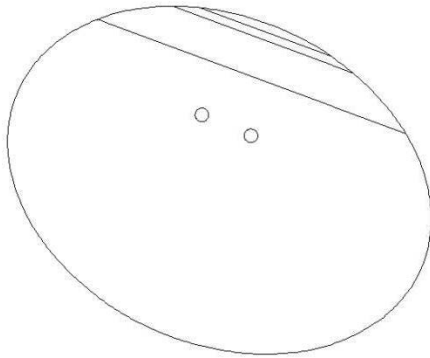

1. Remove tape covering latch holes.

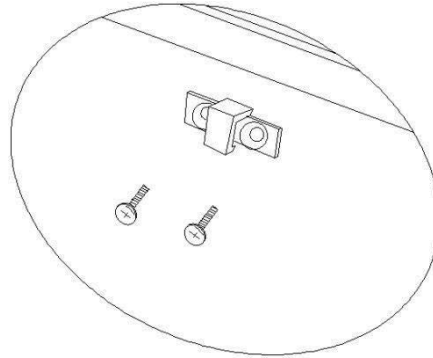

2. Align latch over holes. Align screws over holes.

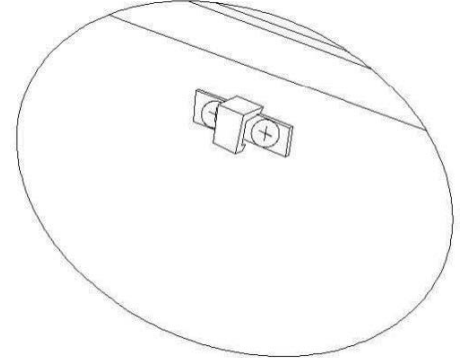

3. Tighten screws in place.

## Handle Installation

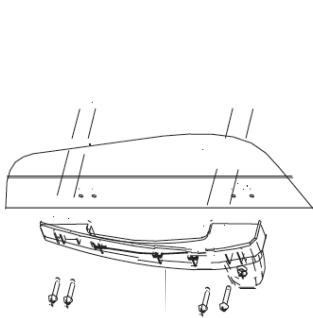

1. Fix the handle on the door with four screws.

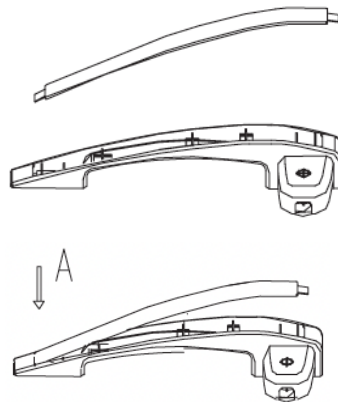

2. Insert the one side of handle cover (A) into the handle pedestal.

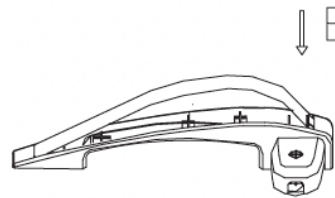

3. Insert the other side of handle cover (B) into the handle pedestal.

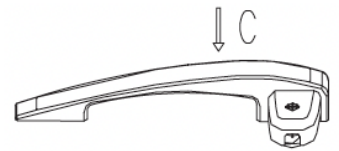

4. Press the cover into the handle pedestal (C).

# BLACK◆DIAMOND®

## FOOD STORAGE

- The use of a freezer is for freezing fresh food and storing frozen food for long periods of time and making ice cubes.
- **DO NOT** put fresh or warm food with frozen food side by side as it can thaw the frozen food.
- While freezing fresh food (i.e. meat, fish etc) divide them into smaller portions, this will allow you to defrost only the food you need.
- For storing frozen food; the instructions shown on frozen food packages should always be followed carefully, if no information is provided food should not be stored for more than 3 months from the purchased date.
- When buying frozen food; ensure that these have been frozen at suitable temperatures and that the packing is intact.
- Frozen food should be transported in appropriate containers to maintain the quality of the food and should be placed into the freezer as soon as possible.
- If a package of frozen food shows signs of humidity and abnormal swelling it is probable that it has been previously stored at an unsuitable temperature and that the contents have deteriorated. **DO NOT** use this food, dispose of it as soon as possible.
- The storage life of frozen food depends on the room temperature, thermostat setting, how often the door is opened, the type of food and the length of time required to transport the product from the shop to your home. Always follow the instructions printed on the package and never exceed the maximum storage life indicated.
- **DO NOT** fill the freezer full of products. You should leave space between items and the inner surface of the cabinet, so as to keep good ventilation of cold air and freeze evenly.
- **DO NOT** put in any bottled or canned beverage with a freezing point above the temperature in the cabinet when it is below zero.
- For foods that should be moisture-free or lose water easily, seal them in hermetical food bags before putting in the cabinet to avoid food odors and reduce frost.
- **DO NOT** store volatile and combustible gases, liquids such as strong alkaline, strong acids, petrol, etc.

## DEFROSTING AND CLEANING

- **WARNING:** Disconnect power cord before cleaning any parts of the unit.
- Keep the power supply and lower part of connect wires away from water to avoid electricity leakage.
- **DO NOT** use boiling water, flammable, explosive or corrosive chemicals, such as acid, petrol and oil, or dirt-removing powder.
- **DO NOT** use steel wool, caustic soap, abrasive cleaners, or bleach.
- **WARNING: DO NOT** use mechanical devices (hairdryers, electrical heaters and other similar electrical appliances) to accelerate the defrosting process.
- **DO NOT** use pointed, sharp objects or tools, (such as steel brushes, knives, or forks) to remove the frost to avoid evaporator damage.
- **DO NOT** wash your freezer by pouring water into it.

Defrost twice a year **or** when a frost layer of around 1/4" (7 mm) has formed.

1. Turn off the power and pull out the power plug from the wall socket.
2. Take out the frozen foods, open the door for warming and melting.  
\* All food should be wrapped and stored in a cold place (e.g. fridge or larder).
3. Containers full of warm water may be placed carefully in the freezer to speed up the defrosting.
4. When defrosting has finished, sponge out any defrost water which collects at the bottom of the freezer and dry the interior thoroughly.
5. Wipe the inner and outer sides with a soft cloth or a sponge using mild soap and warm water.
6. Dry inside and outside of unit with a soft cloth.
7. Once defrosting/cleaning has been completed, plug in the appliance and allow freezer to return to its temperature setting.
8. Replace foods in unit.

# BLACK◆DIAMOND®

## TROUBLE SHOOTING

- Before requesting any service on your unit, please check the following points. Please note that this guide serves only as a reference for solutions to common problems.

ISSUE	POSSIBLE CAUSE		CHECK	SOLUTION
Compressor does not work	Power is off	The fuse is broken	Check the fuse	Replace the fuse
		The connection between plug and socket is not good	Check the socket	Repair or replace the socket
		The circuit of input and output is out of use	Make sure that the power is on	Check the circuit with electric instrument
	The thermostat knob is not in the proper position		Check the thermostat	Rotate the thermostat to the proper position
Compressor keeps on working	The temperature inside is too high	Frost on the evaporator is too thick	Check whether the frost is thicker than 6-8mm	Defrost regularly
		The door is being opened too frequently		Reduce the times of opening
		Too much food has been stored at once		Take out some of the food
	The temperature inside is OK	The ambient temperature is too high while the thermostat indicates a small number	Check if the thermostat knob is at '5' - '6' (or higher)	Adjust the thermostat knob. Recommended setting is from 2 to 4.
		The thermostat does not work	Replace the thermostat	
Too noisy	The floor is not level		Make sure that the freezer is level	Put pad under the castors
	The screw in fan or condenser is loose		The screw is loose	Rotate the fixed screw
	The refrigerating circuits touch each other			Separate them

- If it is necessary, please contact after-sales service for repair

## THE FOLLOWING ARE NOT FAULTS:

ISSUE	CAUSES AND RESOLUTIONS
There is a sound of liquid flowing in the freezer	It is the sound of refrigerant flowing in the circulating pipeline of the refrigerating system, this is normal
Too noisy	The freezer is not installed in a level ground, adjust the freezer's position
The refrigeration system does not work for a long time but the inside temperature is very low	It is an indicator of good insulation and low cooling retention, this is normal.

## REFRIGERATION WARRANTY

### ONE (1) YEAR LIMITED WARRANTY ON PARTS AND LABOR, ONE (1) YEAR WARRANTY ON COMPRESSOR AND EVAPORATOR

The Legacy Companies (the "Company") warrants this product (the "Product") will be free from defects in material and workmanship under normal use and service as specified by the Company for duration of:

- One (1) Year Limited Warranty on Parts and Labor
- One (1) Year Warranty on Compressor and Evaporator

This Limited Warranty is non-transferable.

During the Warranty Period, your exclusive remedy is repair or replacement without charge of the Product or any component found to be defective at the Company's discretion. If the Product or any component is no longer available, the Company will replace it with a similar one of equal or greater value.

The Warranty Period begins at time of installation as documented by registration of the warranty. Registering the warranty is the responsibility of the end user. If the warranty is not registered, the Warranty Period begins at time of purchase. If no proof of purchase is available, the Warranty Period begins at time of shipment from the Company. Under no circumstances does the Warranty Period begin later than 6 months after the time of shipment from the Company.

The obligation of the Company under this warranty is limited to the repair or replacement, at the Company's sole discretion, of defective parts or assemblies that are reported during the Warranty Period and determined by the Company to be defective but excluding all labor charges (except as provided in the next paragraph).

The Company will pay straight time labor at the product location only to repair or replace a defective component for covered defects reported to Company within one (1) year from the date of start of the Warranty Period, provided that the work is performed by a service provider acceptable to the Company. Such charges shall be determined in accordance with the Company's current warranty guidelines and shall exclude charges for overtime, Travel in excess of 100 miles roundtrip, multiple trip charges and other premium charges, which shall be the sole responsibility of the equipment owner. Free and unimpeded access to the equipment must be provided. Labor charges resulting from time required to gain access to the equipment including: security protocols, moving equipment or impediments to gain access, or waiting for equipment to be accessible, will be the sole responsibility of the owner.

Costs expressly excluded from this warranty include, but are not limited to:

- Adjustments
- Cleaning and/or sanitizing
- Consumable/wearable items, such as gaskets, filters, light bulbs, legs, casters, hinges, non-stick cooking surfaces, etc.
- Labor to remove and/or install replacement equipment
- Disposal of defective equipment
- Improper or inadequate utility connections, including but not limited to:
  - \* Voltage outside of data plate specifications
  - \* Improper gas pressure
  - \* Improper gas supply
  - \* Water pressure outside of specified range
  - \* Poor water quality
- External drain malfunction.
- Adverse operating conditions as set forth in the owner/user manual for the product.
- Non-authorized modification of the product.
- Improper installation of the product, including installation in a hostile environment
- Improper maintenance, abuse or misuse of the product.
- Causes beyond the reasonable control of the Company, including without limitation fires, freezing, floods and other natural disasters.
- Damage during transit.

No warranty shall apply to any product on which the model or serial number has been altered or removed. Adjustments or modifications to any equipment manufactured by the Company are not covered by this warranty.

This Warranty only extends to the original owner/end user and is not transferable or applicable to products sold through unauthorized channels.

This Warranty covers installations for Commercial use only. Any installation in a residential location is not covered.

This warranty applies to the original installation location only.

Equipment installed in a mobile environment (food truck, RV, boat, etc.) or outdoors will have a Warranty Period of 30 days unless expressly endorsed for the application in the Company's sales information.

All warranty requests are to be made through the Company's Warranty and Technical Service team. All warranty requests shall include the product model and serial number, original installation date and/or Proof of Purchase, photo of the equipment serial number data plate and complete customer identification and location.

Replacement parts are warranted for 90 days or the balance of the original Warranty Period, whichever is greater. Company and its agents are expressly permitted to specify rebuilt parts as suitable replacement parts. All replacement parts must be approved Company parts obtained through the Company or a Company approved parts distributor.

THIS WARRANTY IS IN LIEU OF ALL IMPLIED WARRANTIES, INCLUDING WARRANTIES OF MERCHANTABILITY, FITNESS FOR A PARTICULAR PURPOSE, PERFORMANCE, OR OTHERWISE, WHICH ARE HEREBY EXCLUDED. IN NO EVENT SHALL THE COMPANY BE LIABLE FOR ANY DAMAGES, WHETHER DIRECT, INDIRECT, INCIDENTAL, FORESEEABLE, CONSEQUENTIAL, OR SPECIAL ARISING OUT OF OR IN CONNECTION WITH THIS PRODUCT INCLUDING DAMAGES ARISING FOR LOSS OF PROFIT, FOOD OR BEVERAGE SPOILAGE CLAIMS, OR OTHER COMMERCIAL LOSS.

You may have other legal rights depending upon where you live. Some States or Provinces do not allow limitations on warranties so the foregoing may not apply to you.