

BLACK DIAMOND®

Project Name: _____

Location: _____

Item #: _____

Qty: _____

Black Diamond Ice Cream Dipping Cabinet, 20 Tub, 20.1 cu ft Capacity, in White

USDP-67



Enhance ice cream and gelato service with the Black Diamond Ice Cream Dipping Cabinet, designed for high-volume parlors, dessert shops, and restaurants. Offering a 20.1 cu. ft. capacity and efficient compressor cooling, it ensures products are maintained between -10° and 5°F for ideal serving consistency. Its durable white exterior, aluminum interior, and polycarbonate glass lids optimize hygiene and display, while an eco-friendly R290 refrigerant and electronic controls provide sustainability and ease of use.

FEATURES AND CONSTRUCTION

- Capacity of 20.1 cu ft supports up to 20 three-gallon tubs, with 12 on display and 8 in storage
- Equipped with a 1/2 HP compressor for efficient cooling performance
- Constructed with a durable aluminum interior for easy cleaning
- Maintains a temperature range of -10° to 5°F
- Lift-up polycarbonate glass lids provide durability and exceptional product visibility
- Includes 6 adjustable shelves for flexible, organized storage
- Fixed base with no casters ensures secure and stable placement
- Includes stainless steel top shelf for extra storage space
- Glass canopy provides clear visibility of ice cream flavors

ELECTRIC

115V / 60Hz / 1Ph

Cord Length (Inches): 98.40"

Plug Type: NEMA 5-15P

Cord set included

NEMA 5-15P



3RD PARTY APPROVALS



WARRANTY (USA / CANADA)

Two (2) Year Limited Warranty on Parts and Labor, Five (5) Year Warranty on Compressor and Evaporator

Contact us for details at 1.877.368.2797



INCLUDED COMPONENTS

- Shelves

STORAGE CAPACITY

- Cubic Feet: 20.1 cu. ft.
- Display: (12) 3 Gal Containers, Storage: (8) 3 Gal Containers

TEMPERATURE

- Holding Temperature (Fahrenheit): -10° - 5°

These models are designed to operate in an environment where temperature and humidity do not exceed 75°F (24°C) and 55% relative humidity

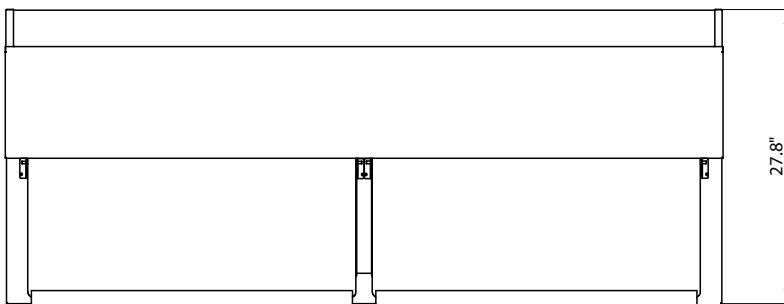
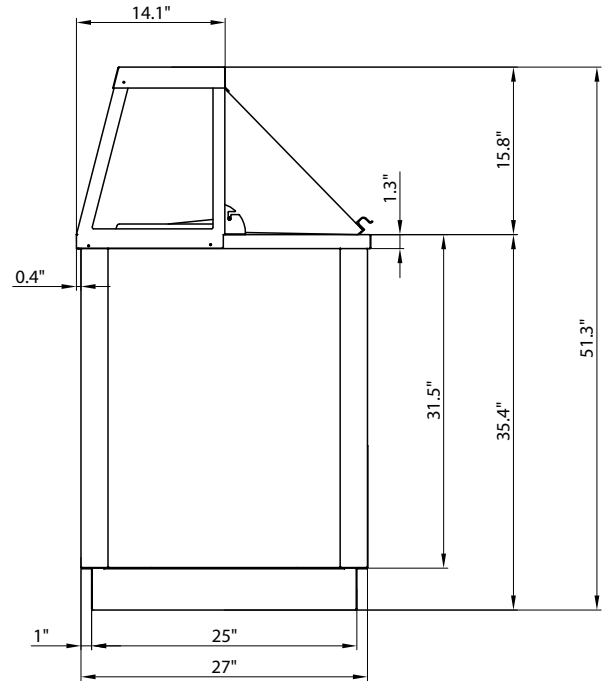
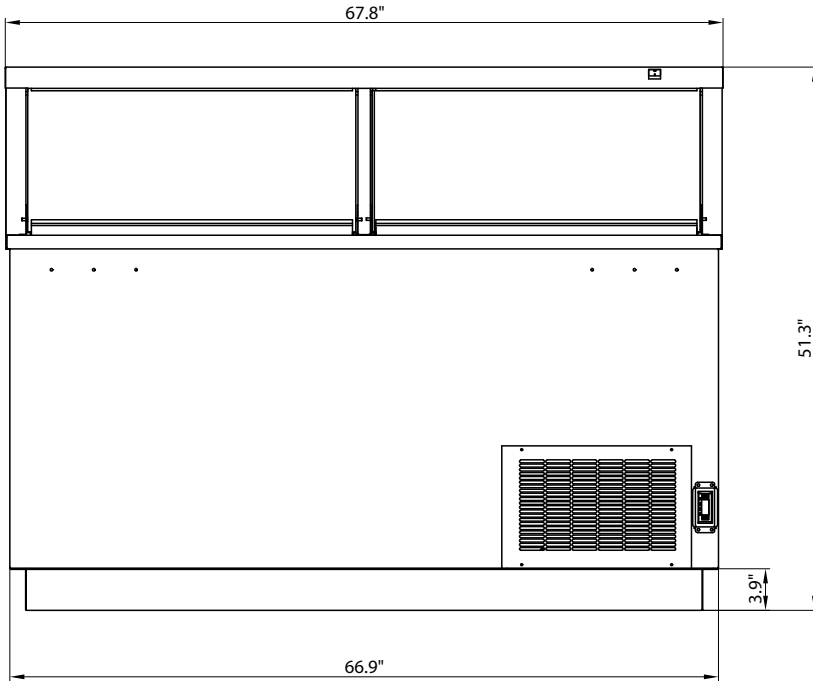

TOP

Dipping Cabinet

Total Tub Storage	Tub Display / Storage	Amps	HP	Refrigerant	Assembled Dimensions (in)	Item Weight (lbs)	Shipping Weight (lbs)
(20) 3 Gal Containers	Display: (12) 3 Gal Containers Storage: (8) 3 Gal Containers	5.64A	1/2	R290 3.53	67.80" x 27.80" x 51.30"	308.7	444.0

Due to periodic changes in designs, methods, procedures, policies and regulations, the specifications contained in this document are subject to change without notice. While we exercise good faith efforts to provide information that is accurate, we are not responsible for errors or omissions in information provided or conclusions reached as a result of using the specifications. By using the information provided, the user assumes all risks in connection with such use.