

# ASSEMBLY INSTRUCTION

## 36" COUNTER HEIGHT TABLE

**A** Table Top



1pc

**B** Table Leg



4pcs

**C** Jcbc Bolt  
M8 x 80mm

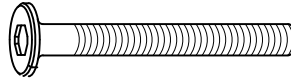

8 pcs

**D** Spring Washer  
M8



8 pcs

**E** Flat Washer  
M8 x 22mm



8 pcs

**F** Allen Key  
M8 x 60



1 pc



This page lists all the contents included in the box. Please take the time to identify the hardware as well as the individual components to this product. As you unpack and prepare for assembly, place the contents on a carpeted or padded area to protect them from damage.

**1**

Put the Table Top (A) upside down on the soft and smooth surface. Attach Table Leg (B) onto Table Top (A). Then insert Jcbc Bolt (C), Spring Washer (D) and Flat Washer (E) into holes of each corner block of Table Top (A), by using Allen Key (F).

\*\*\*Do not fully tighten the nut or bolts until all nuts and bolts are attached.

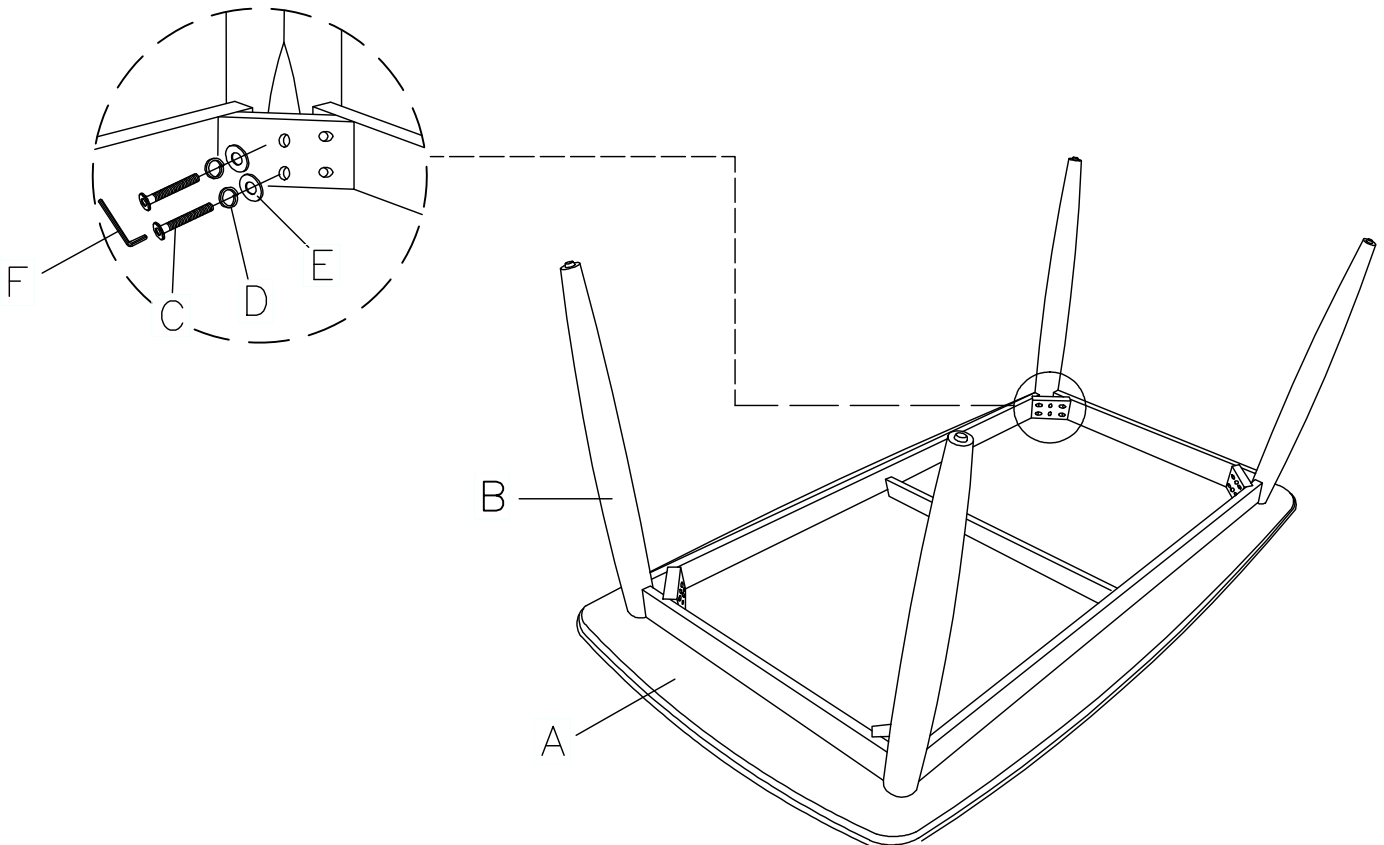

Stand table up on an even surface and check that it is balanced. If there is a slight wobble, apply downward pressure in the corner where a leg is uneven. Keeping pressure in that corner, tighten all bolts. If balanced, apply downward pressure evenly in the center and tighten all bolts. Do not over-tighten beyond hole depth.

#### Cleaning & Care

Treat surface with care. Surface is resistant to scratches but is not scratch resistant. Clean surface with a dry or damp soft cloth. Do not use abrasive cleaners. Hardware may loosen over time. Periodically check that all connections are tight.

# ASSEMBLY INSTRUCTION

## 24" COUNTER HEIGHT CHAIR

**A** Back Rest

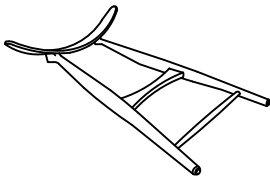

1pc

**B** Front Leg Frame

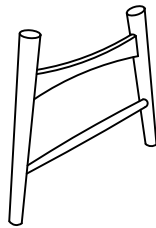

1pc

**C** Side Rail -  
LSF/RSF

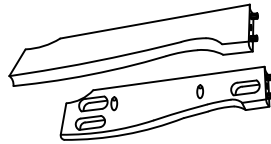

2pcs

**D** Cushion



1pc

**E** Stretcher

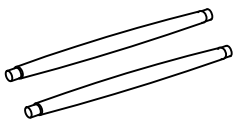

2pcs

**F** Jcbc Bolt  
M6 x 50mm

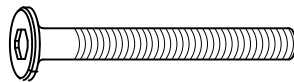

6 pcs

**G** Spring Washer  
M6



6 pcs

**H** Flat Washer  
M6 x 13mm



6 pcs

**I** Pan Head Screw  
M4 x 32mm

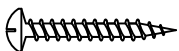

8 pcs

**J** Allen Key  
M4 x 110



1pc

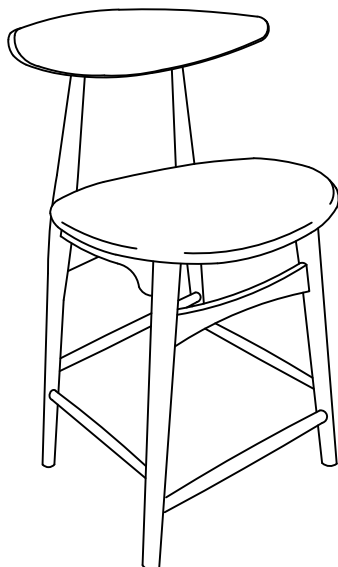

This page lists all the contents included in the box. Please take the time to identify the hardware as well as the individual components to this product. As you unpack and prepare for assembly, place the contents on a carpeted or padded area to protect them from damage.

- 1** Put the Back Rest (A) upside down on the soft and smooth surface. With assistance attach Side Rail - LSF/RSF (C) onto Back Rest (A). Insert Stretcher (E) into hole on Back Rest (A). Then insert Jcbc Bolt (F), Spring Washer (G) and Flat Washer (H) into predrilled holes of each Side Rail, by using Allen Key (J). Do not fully tighten the bolts in this step.

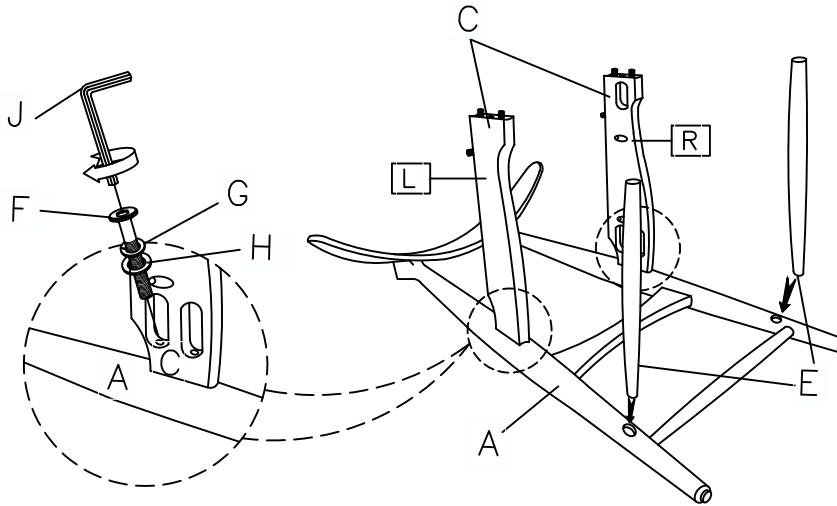

Take the Allen Wrench, and turn the bolts until the legs are secure.  
**DO NOT TIGHTEN COMPLETELY.**  
Stop when you feel you are adding force to tighten the bolt.

- 2** Attach Front Legs Frame (B) onto Side Rail LSF/RSF (C), insert Flat Washer (H), Spring Washer (G) and Jcbc Bolt (F) using Allen Key (J). Put Pan Head Screw (I) by using Screwdriver (not included) into screw hole on Stretcher (E).

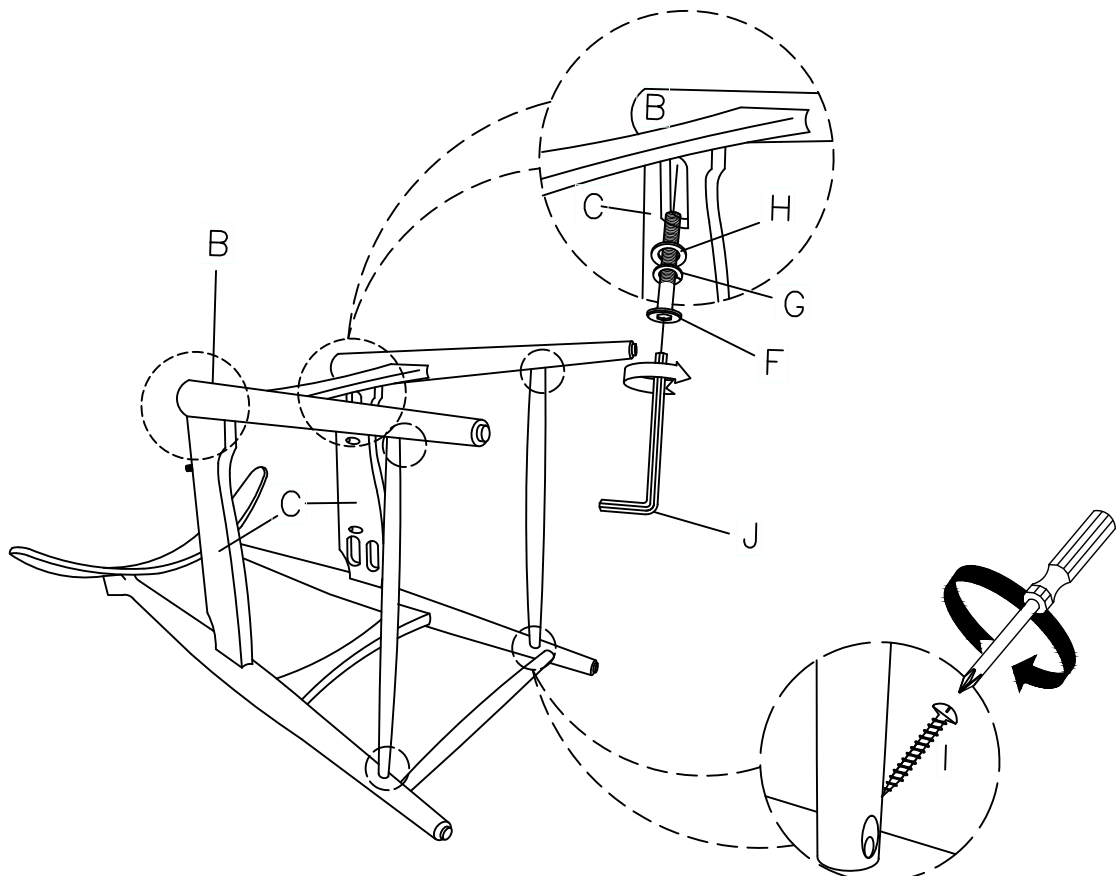

- 3** Stand chair up on an even surface and check that it is balanced. If there is a slight wobble, apply downward pressure on each corner where a leg is uneven. Keeping pressure in that corner, tighten all bolts. If balanced, apply downward pressure evenly in the center and tighten all bolts. Tighten all JCBC by using Allen Key (J).

While the chair legs uneven after assembled, please adjust the adjustable glide to make it balance.

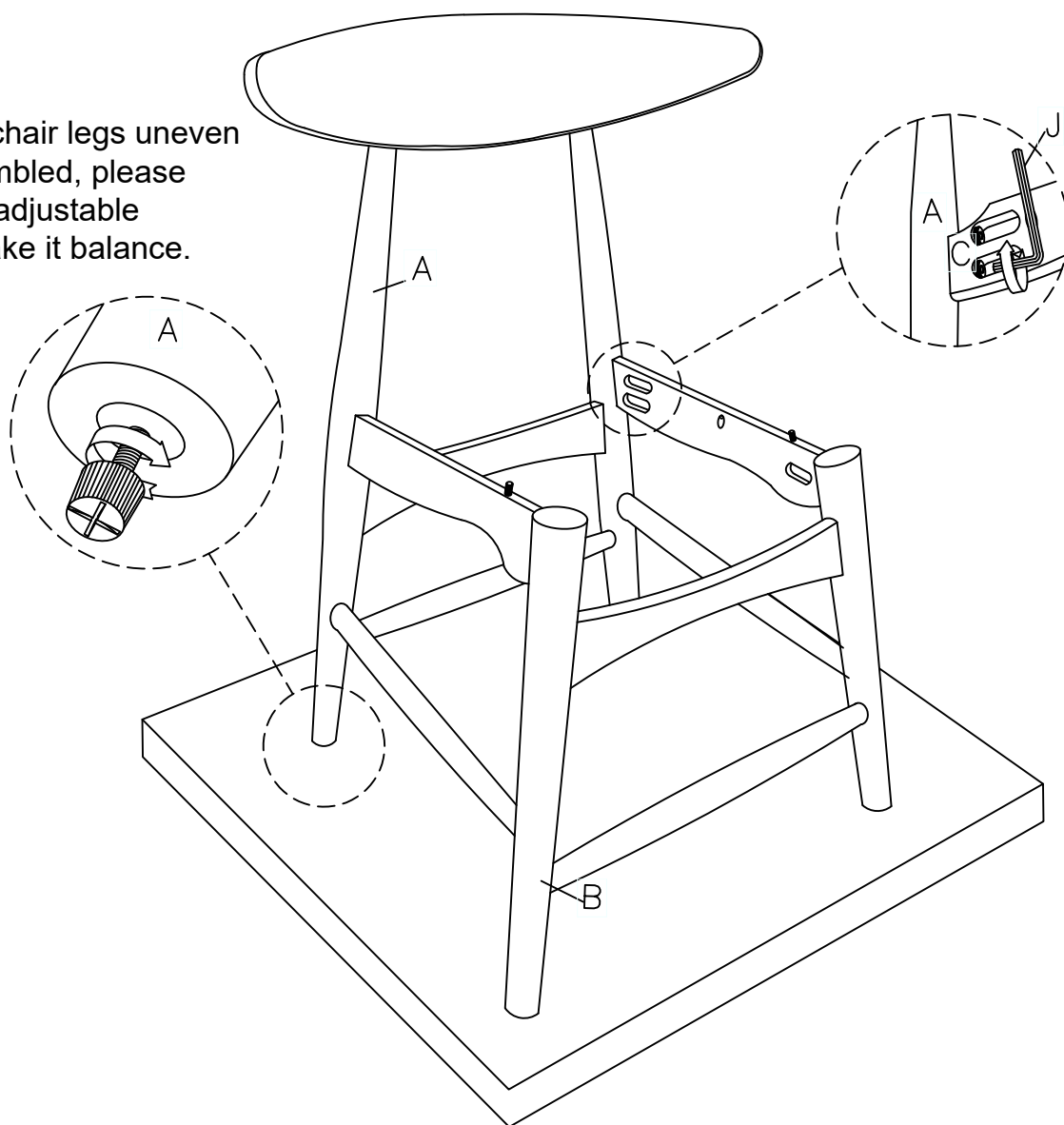

*Helpful Tip:-*Have someone applying downward pressure on the chair while you tighten the bolts.

- 4** Attach Cushion (D) with Pan Head Screw (I) by using Screwdriver (not included). Tighten all wood screws in this step.

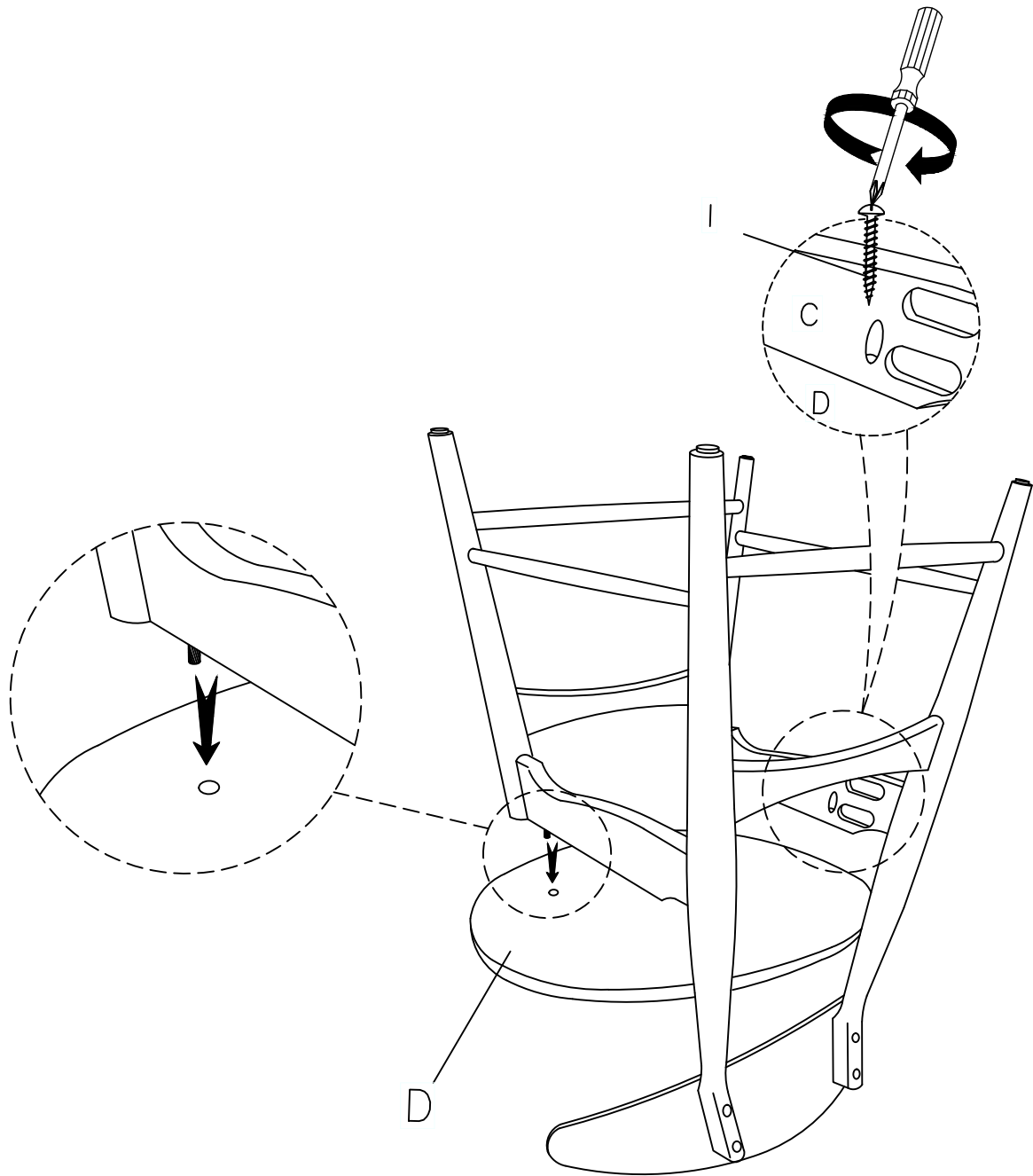

#### Cleaning & Care

Treat surface with care. Surface is resistant to scratches but is not scratch resistant. Clean surface with a dry or damp soft cloth. Do not use abrasive cleaners. Hardware may loosen over time. Periodically check that all connections are tight.