



MANUFACTURED BY:  
Backyard Discovery  
3305 Airport Drive, Pittsburg, KS 66762  
800-856-4445

Basepoint Business Centre: Rivermead Drive, Westlea, Swindon SN5 7EX Phone: 0800-118-2476  
J.P. Coenstraat 7, The Bridge, The Hague, 2595 WP, Netherlands Phone: 0800-567-8990

# ROSEWOOD FALLS

## Swing Set

### Model # 2400092

The assembly manual must be retained  
since it contains important information



#### WARNING

**Adult Assembly Required.**

**Not suitable for children under 36 months due to small parts.**

**FOR DOMESTIC USE ONLY. INTENDED FOR OUTDOOR USE.**

CAN ICES-003 (B)/NMB-003 (B)



**Please visit [www.backyarddiscovery.com](http://www.backyarddiscovery.com)**

For the most up to date assembly manual, to register your set, or to order replacement parts

*Para obtener instrucciones en español, visite [www.backyarddiscovery.com](http://www.backyarddiscovery.com)*



**EASY STEP-BY-STEP**  
**3D INTERACTIVE INSTRUCTIONS**

DOWNLOAD THE FREE APP



# Owner's Manual - Basic Setup Dimensions & Assembly Notes

Place the set on level ground, not less than 6'-7" [2 m] from any structure or obstruction such as a fence, garage, house, overhanging branches, laundry lines, or electrical wires.

- While assembling unit, take time before and after each phase to make sure fort is level. If fort is not level, assembly will be difficult and improper assembly may result. Extra care must be taken to insure the fort is square.
- The safe play area refers to a zone extending 6'-7" (2 m) beyond the play product on all sides, including the space above the play product.

## SAFE PLAY AREA DIAGRAM

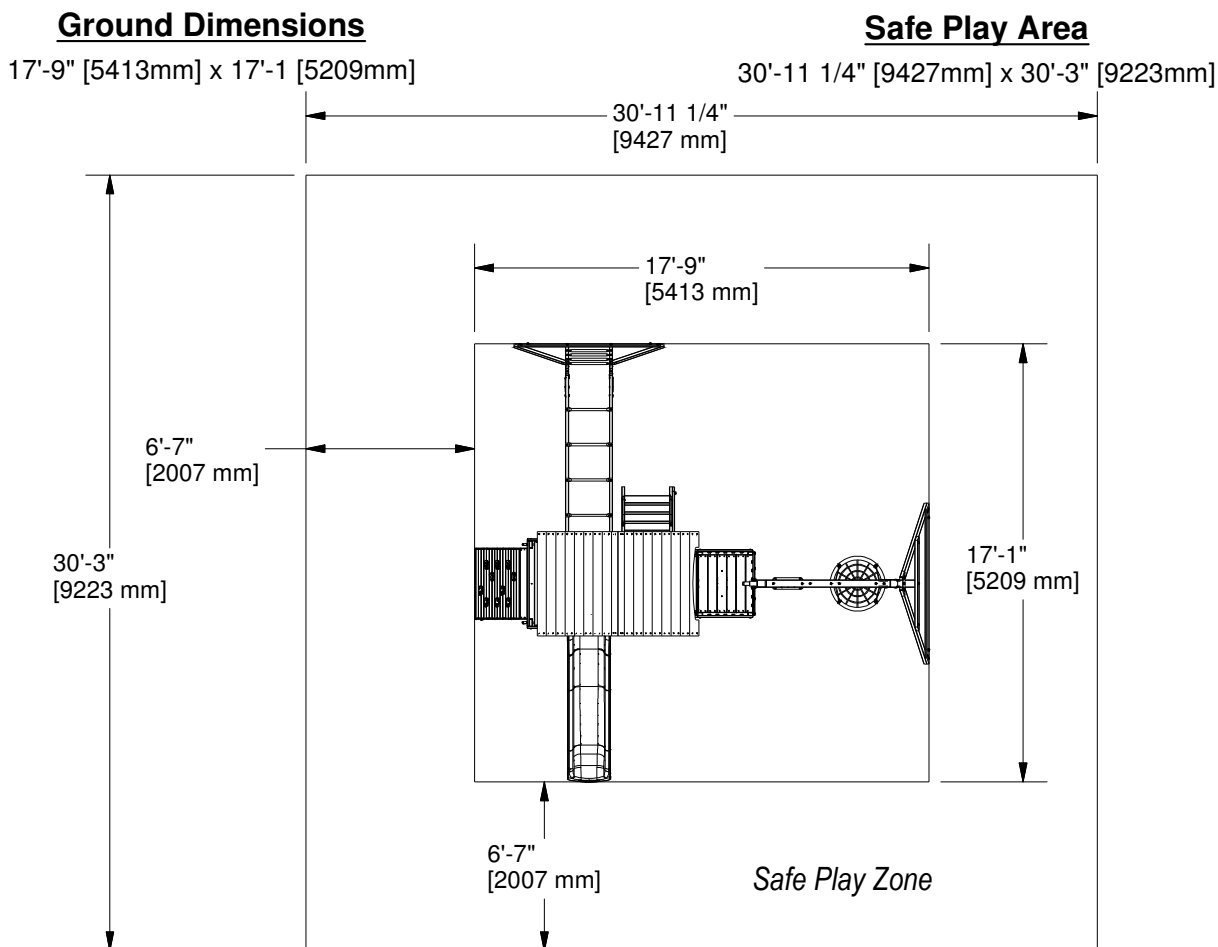

**SAFE PLAY HEIGHT: 17'-1 3/4" [5228mm]**  
**MAXIMUM FALL HEIGHT: 6'-3/4" [1847mm]**

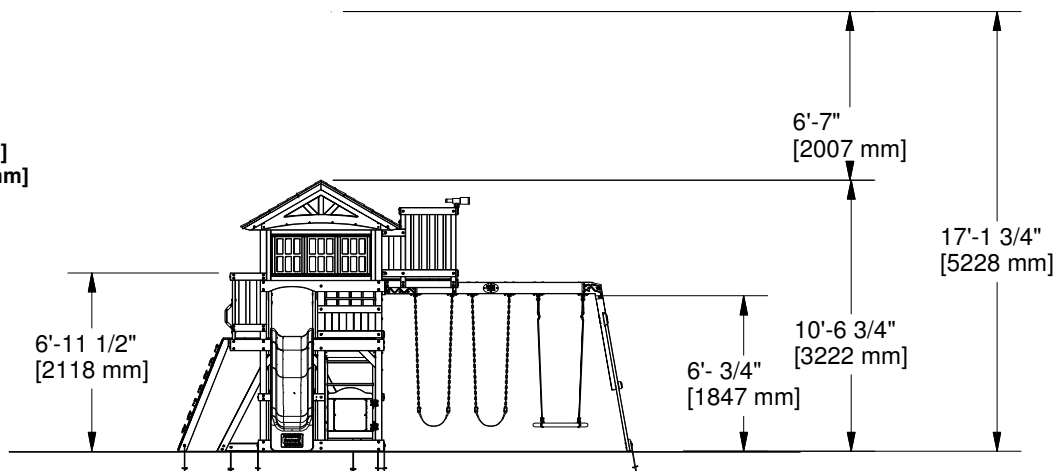

### General Information:

Your set has been designed and engineered for children only and for residential use only.  
 A maximum of 150 lbs. per child is recommended for play activities designed for individual use.  
 A maximum of 120 lbs. per child is recommended for play activities designed for multiple child use.  
 A maximum of 12 children is recommended for this swing set.

# Owner's Manual - Parts Identification

## Wood Components (Not to Scale)



**A1 SWING BEAM EXTENDED - W4L21338**  
(x1) 3 3/8"x5 1/4"x89 1/2" (86x134x2274)



**A2 SB 9" BLOCK - W4L21339**  
(x1) 3 3/8"x5 1/4"x9" (86x134x228)



**AD02 WALL RAIL - W4L21401**  
(x2) 1"x3 7/8"x65 3/4" (24x100x1670)

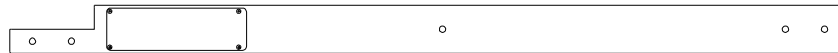

**B01 POST ASSEMBLY - W2A04616**  
(x1) 3"x3"x63 7/16" (76x76x1330)

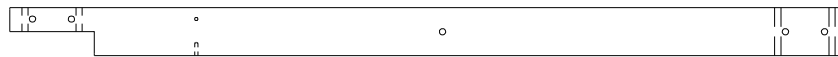

**B02 POST - W4L21356**  
(x1) 3"x3"x52 3/8" (76x76x1330)

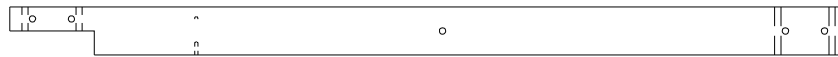

**B03 POST - W4L21357**  
(x1) 3"x3"x52 3/8" (76x76x1330)



**B04 POST - W4L21358**  
(x1) 3"x3"x52 3/8" (76x76x1330)



**B05 POST - W4L21383**  
(x1) 3"x3"x60 3/8" (76x76x1532)



**B06 POST - W4L21384**  
(x1) 3"x3"x60 3/8" (76x76x1532)



**B07 POST - W4L21385**  
(x1) 3"x3"x60 3/8" (76x76x1532)



**B08 POST - W4L21386**  
(x1) 3"x3"x60 3/8" (76x76x1532)

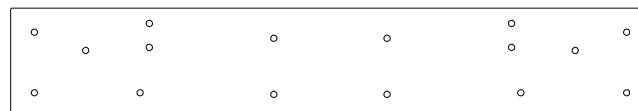

**C01 TOP SWING BEAM RAIL - W4L21390**  
(x1) 1 3/8"x6 3/4"x40" (36x172x1017)

# Owner's Manual - Parts Identification

## Wood Components (Not to Scale)



**E01 ANGLE BRACE - W4L21379**  
(x8) 1 7/16"x3 3/8"x17 1/2" (36x86x444)



**E02 WALL BOARD - W4L21402**  
(x2) 1 3/8"x3 3/8"x54 3/8" (36x86x1382)



**E03 CROWS NEST FLOOR RAIL - W4L21340**  
(x2) 1 3/8"x3 3/8"x33 1/4" (36x86x846)

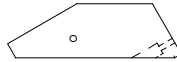

**E04 CROWS NEST DECK BRACE - W4L21341**  
(x2) 1 7/16"x3 3/8"x10 7/8" (36x86x276)



**E05 WALL UPRIGHT - W4L21364**  
(x1) 1 3/8"x3 3/8"x49 1/2" (36x86x1256)

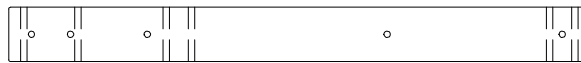

**E06 UPRIGHT - W4L21417**  
(x2) 1 3/8"x3 3/8"x36 1/4" (36x86x922)



**E09 UPRIGHT - W4L21332**  
(x2) 1 3/8"x3 3/8"x57 3/8" (36x86x1456)



**E11 RIGHT UPRIGHT - W4L21322**  
(x1) 1 3/8"x3 3/8"x57 3/8" (36x86x1456)



**E12 LEFT UPRIGHT - W4L21321**  
(x1) 1 3/8"x3 3/8"x57 3/8" (36x86x1456)



**E13 MONKEY BAR UPRIGHT - W4L21419**  
(x2) 1 3/8"x3 3/8"x77 3/8" (36x86x1966)



**E74 MONKEY BAR RAIL - W4L21422**  
(x2) 1 3/8"x3 3/8"x77 1/8" (36x86x1959)

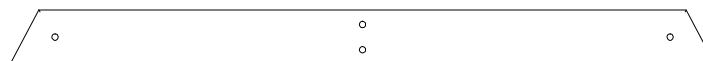

**E79 END SUPPORT - W4L21336**  
(x1) 1 1/2"x3 1/2"x44" (36x86x1120)

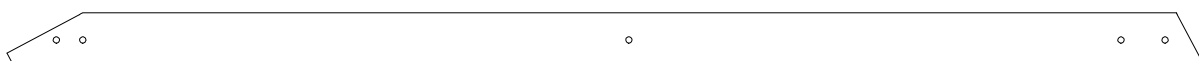

**E80 ANGLE BRACE - W4L21335**  
(x2) 1 3/8"x3 3/8"x74 7/8" (36x86x1903)

# Owner's Manual - Parts Identification

## Wood Components (Not to Scale)

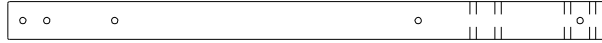

**F01 CROWS NEST WALL SUPPORT - W4L21405**  
(x2) 1 3/8"x2 3/8"x37 1/2" (36x60x952)



**F02 CROWS NEST WALL SUPPORT - W4L21406**  
(x2) 1 3/8"x2 3/8"x37 1/2" (36x60x952)



**G01 GROUND BOARD - W4L21359**  
(x1) 1"x5 1/4"x59" (24x134x1498)



**G02 GROUND BOARD - W4L21360**  
(x2) 1"x5 1/4"x40" (24x134x1017)



**G03 GROUND BOARD - W4L21418**  
(x1) 1"x5 1/4"x59" (24x134x1498)

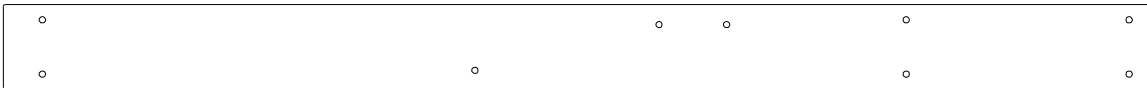

**G04 FLOOR RAIL - W4L21373**  
(x1) 1"x5 1/4"x72" (24x134x1830)



**G05 FLOOR RAIL - W4L21374**  
(x1) 1"x5 1/4"x72" (24x134x1830)

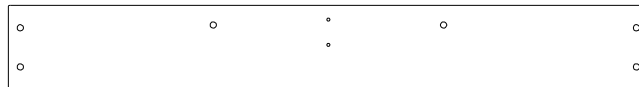

**G06 FLOOR RAIL - W4L21375**  
(x1) 1"x5 1/4"x40" (24x134x1017)

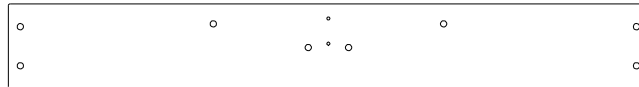

**G07 FLOOR RAIL - W4L21376**  
(x1) 1"x5 1/4"x40" (24x134x1017)

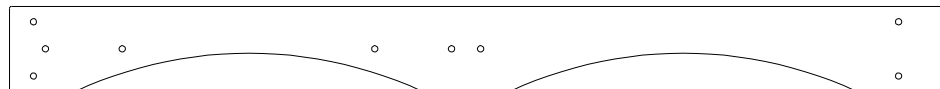

**G08 BACK ARCHED RAIL - W4L21389**  
(x1) 1"x5 1/4"x58 1/2" (24x134x1486)

# Owner's Manual - Parts Identification

## Wood Components (Not to Scale)



**G11 FLOOR RAIL - W4L21394**  
(x1) 1"x5 1/4"x40" (24x134x1017)

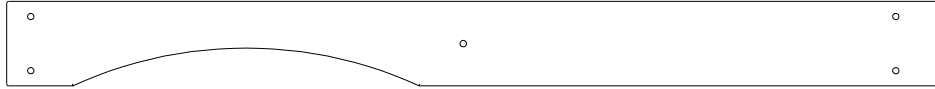

**G12 FRONT ARCHED RAIL - W4L21388**  
(x1) 1"x5 1/4"x58 1/2" (24x134x1486)



**G13 GROUND BOARD - W4L21349**  
(x1) 1"x5 1/4"x24 3/8" (24x134x618)



**G50 GROUND BOARD - W4L21334**  
(x1) 1"x5 1/4"x75 1/4" (24x134x1912)



**H01 COUNTERTOP RAIL - W4L21362**  
(x1) 1"x3 3/8"x31 1/8" (24x86x792)

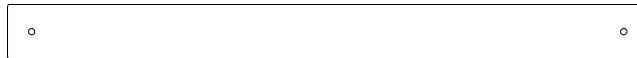

**H02 WALL RAIL - W4L21363**  
(x1) 1"x3 3/8"x40" (24x86x1017)



**H03 SLIDE RAIL - W4L21355**  
(x1) 1"x3 3/8"x40" (24x86x1017)



**H04 WALL RAIL - W4L21365**  
(x1) 1"x3 3/8"x40" (24x86x1017)



**H05 FLOOR JOIST - W4L21377**  
(x1) 1"x3 3/8"x57 1/8" (24x86x1450)



**H06 FLOOR BLOCK - W4L21378**  
(x4) 1"x3"x3 3/8" (24x76x86)

# Owner's Manual - Parts Identification

## Wood Components (Not to Scale)



**H07 WALL RAIL - W4L21382**  
(x2) 1"x3 3/8"x40" (24x86x1017)



**H08 WALL RAIL - W4L21387**  
(x2) 1"x3 3/8"x17" (24x86x432)

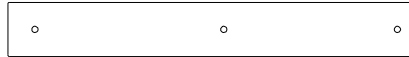

**H09 WALL BOARD - W4L21391**  
(x1) 1"x3 3/8"x25 5/8" (24x86x650)

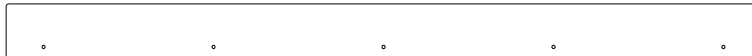

**H10 WINDOW TRIM - W4L21392**  
(x4) 1"x3 3/8"x47 1/8" (24x86x1198)



**H11 ATTACHMENT BOARD - W4L21423**  
(x1) 1"x3 3/8"x33 1/4" (24x86x843)



**H13 WALL BOARD - W4L21397**  
(x1) 1"x3 3/8"x25 5/8" (24x86x650)



**H14 WALL BOARD - W4L21403**  
(x2) 1"x3 3/8"x54 3/8" (24x86x1382)



**H15 WALL BOARD - W4L21353**  
(x2) 1"x3 3/8"x30 1/4" (24x86x768)

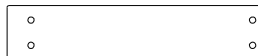

**H16 WALL RAIL - W4L21354**  
(x2) 1"x3 3/8"x16 1/8" (24x86x408)



**H18 CROWS NEST FLOOR RAIL - W4L21342**  
(x1) 1"x3 3/8"x27" (24x86x686)



**H19 CROWS NEST FLOOR SUPPORT - W4L21343**  
(x1) 1"x3 3/8"x24 1/8" (24x86x614)



**H20 FLOOR JOIST - W4L21407**  
(x1) 1"x3 3/8"x12 1/8" (24x86x308)



**H21 CROWS NEST WALL RAIL - W4L21408**  
(x2) 1"x3 3/8"x29 7/8" (24x86x758)

# Owner's Manual - Parts Identification

## Wood Components (Not to Scale)



**H22 CROWS NEST WALL RAIL - W4L21409**  
(x2) 1"x3 3/8"x34 3/4" (24x86x882)



**H23 CROWS NEST WALL RAIL - W4L21411**  
(x2) 1"x3 3/8"x26" (24x86x660)



**H24 CROWS NEST WALL RAIL - W4L21412**  
(x2) 1"x3 3/8"x11 1/8" (24x86x282)



**H25 ATTACHMENT BOARD - W4L21325**  
(x1) 1"x3 3/8"x23 7/8" (24x86x606)



**H26 LADDER RUNG - W4L21323**  
(x4) 1"x3 3/8"x21 3/4" (24x86x554)

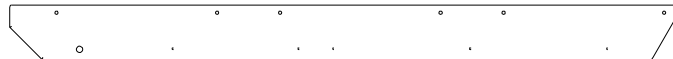

**H27 LEFT ROOF RAFTER - W4L21415**  
(x2) 1"x3 3/8"x42 1/8" (24x86x1069)

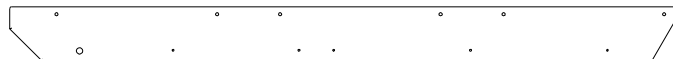

**H28 RIGHT ROOF RAFTER - W4L21416**  
(x2) 1"x3 3/8"x42 1/8" (24x86x1069)



**H81 MONKEY BAR BRACE - W4L21420**  
(x2) 1"x3 3/8"x51 5/8" (24x86x1311)



**H82 MONKEY BAR GROUND BOARD - W4L21421**  
(x1) 1"x3 3/8"x70 3/8" (24x86x1786)



**J01 COUNTERTOP RAIL - W4L21366**  
(x1) 1"x2 3/8"x26 7/8" (24x60x682)



**J02 COUNTERTOP RAIL - W4L21367**  
(x1) 1"x2 3/8"x10 3/4" (24x60x272)



**J03 COUNTERTOP RAIL - W4L21368**  
(x1) 1"x2 3/8"x10 3/4" (24x60x272)

# Owner's Manual - Parts Identification

## Wood Components (Not to Scale)



**J04 BAY WINDOW SIDE - W4L21348**  
(x4) 1"x1 7/8"x18 1/4" (24x48x464)



**J05 WINDOW TRIM - W4L21393**  
(x4) 1"x2"x26 1/4" (24x50x668)



**K01 COUNTERTOP BOARD - W4L21372**  
(x1) 5/8"x5 1/4"x26 7/8" (16x134x682)

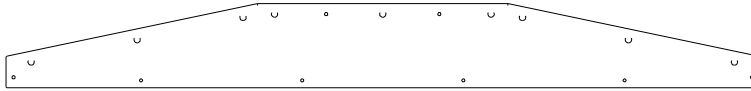

**K02 BAY WINDOW HEADER - W4L21347**  
(x4) 5/8"x5 1/4"x47 1/8" (16x134x1197)



**K03 CROWS NEST FLOOR BOARD - W4L21346**  
(x1) 5/8"x5 1/4"x27" (16x134x686)



**L03 CROWS NEST FLOOR BOARD - W4L21344**  
(x6) 5/8"x4 3/8"x27" (16x112x686)



**L04 CROWS NEST FLOOR BOARD - W4L21345**  
(x1) 5/8"x4 3/8"x27" (16x112x686)

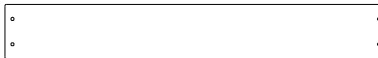

**M01 PICKET - W4L21369**  
(x18) 5/8"x3 3/8"x23 7/8" (16x86x606)



**M02 COUNTERTOP BOARD - W4L21370**  
(x1) 5/8"x3 3/8"x26 7/8" (16x86x682)



**M03 COUNTERTOP BOARD - W4L21371**  
(x1) 5/8"x3"x23 7/8" (16x76x605)

# Owner's Manual - Parts Identification

## Wood Components (Not to Scale)



**M04 FLOOR BOARD - W4L21381**  
(x15) 5/8"x3 3/8"x41 7/8" (16x86x1065)



**M05 WALL BOARD - W4L21404**  
(x6) 5/8"x3 3/8"x27" (16x86x686)



**M06 CROWS NEST WALL RAIL - W4L21410**  
(x2) 5/8"x3 3/8"x29 7/8" (16x86x758)



**M07 WALL RAIL - W4L21395**  
(x1) 5/8"x3 3/8"x40" (16x86x1017)

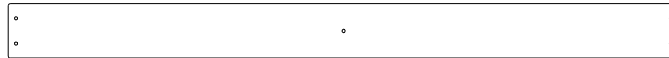

**M08 FLOOR BOARD - W4L21398**  
(x3) 5/8"x3 3/8"x41 7/8" (16x86x1065)



**M09 FLOOR BOARD - W4L21400**  
(x1) 5/8"x3 3/8"x34" (16x86x863)



**M10 FLOOR BOARD - W4L21396**  
(x1) 5/8"x3 3/8"x41 7/8" (16x86x1065)



**M12 REAR SUPPORT - W4L21324**  
(x1) 5/8"x3 3/8"x23 7/8" (16x86x606)



**M13 ROCK BOARD - W4L21328**  
(x9) 5/8"x3 3/8"x33 1/4" (16x86x843)



**M14 WALL BOARD - W4L21352**  
(x7) 5/8"x3 3/8"x11 3/4" (16x86x300)



**M15 ROCK BOARD - W4L21329**  
(x4) 5/8"x3 3/8"x33 1/4" (16x86x843)

# Owner's Manual - Parts Identification

## Wood Components (Not to Scale)



**M16 ROCK BOARD - W4L21330**  
(x3) 5/8"x3 3/8"x33 1/4" (16x86x843)



**M17 TOP BOARD - W4L21333**  
(x1) 5/8"x3 3/8"x33 1/4" (16x86x843)



**N02 CROWS NEST WALL BOARD - W4L21414**  
(x2) 5/8"x2 3/8"x22 3/8" (16x60x568)



**N04 ROCK WALL BOARD - W4L21327**  
(x1) 5/8"x1 5/8"x33 1/4" (16x40x843)



**N05 ROCKWALL CLEAT - W4L21331**  
(x1) 5/8"x2 3/8"x53 7/8" (16x60x1370)



**O01 CROWS NEST WALL BOARD - W4L21413**  
(x16) 5/8"x1 3/8"x32 1/4" (16x34x819)

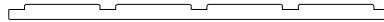

**S01 WINDOW FRAME - W4L21351**  
(x1) 1"x1"x23 7/8" (24x24x605)



**S02 WINDOW FRAME - W4L21350**  
(x5) 1"x1"x9 3/8" (24x24x237)



**SP71 SWING BEAM SUPPORT - W4L21337**  
(x1) 3 3/8"x3 3/8"x49 1/2" (86x86x1256)

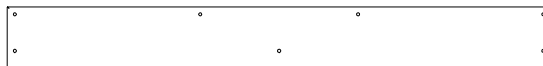

**Y01 FLOOR BOARD - W4L21380**  
(x1) 5/8"x3 7/8"x34" (16x100x864)

# Owner's Manual - Parts Identification

## Wood Components (Not to Scale)

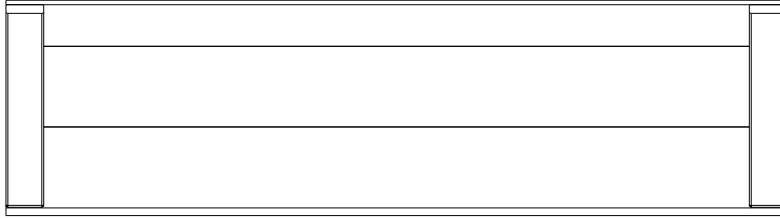

**RP1 PEAK ROOF PANEL - W2A04618**  
(x2) 1 5/8"x13 3/8"x48 7/8" (42x341x1241)



**RP2 ROOF PANEL - W2A04617**  
(x3) 1 5/8"x15 5/8"x59 3/8" (42x396x1241)

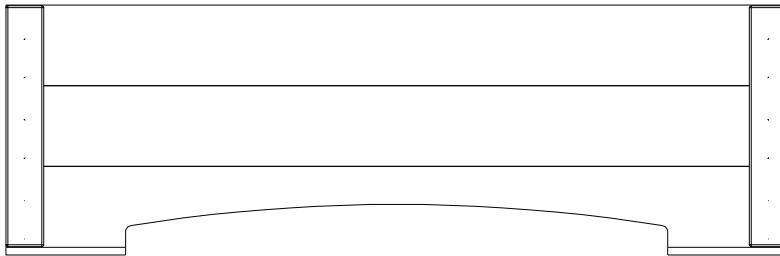

**RP3 ROOF PANEL - W2A04619**  
(x1) 1 5/8"x15 5/8"x59 3/8" (42x396x1241)

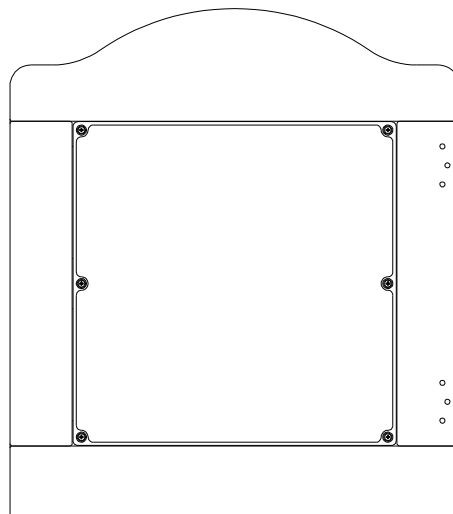

**DR1 DOOR ASSEMBLY - W2A04620**  
(x1) 1 1/4"x21 1/16"x23 7/8" (32x535x606)

# Owner's Manual - Parts Identification

## Hardware Components

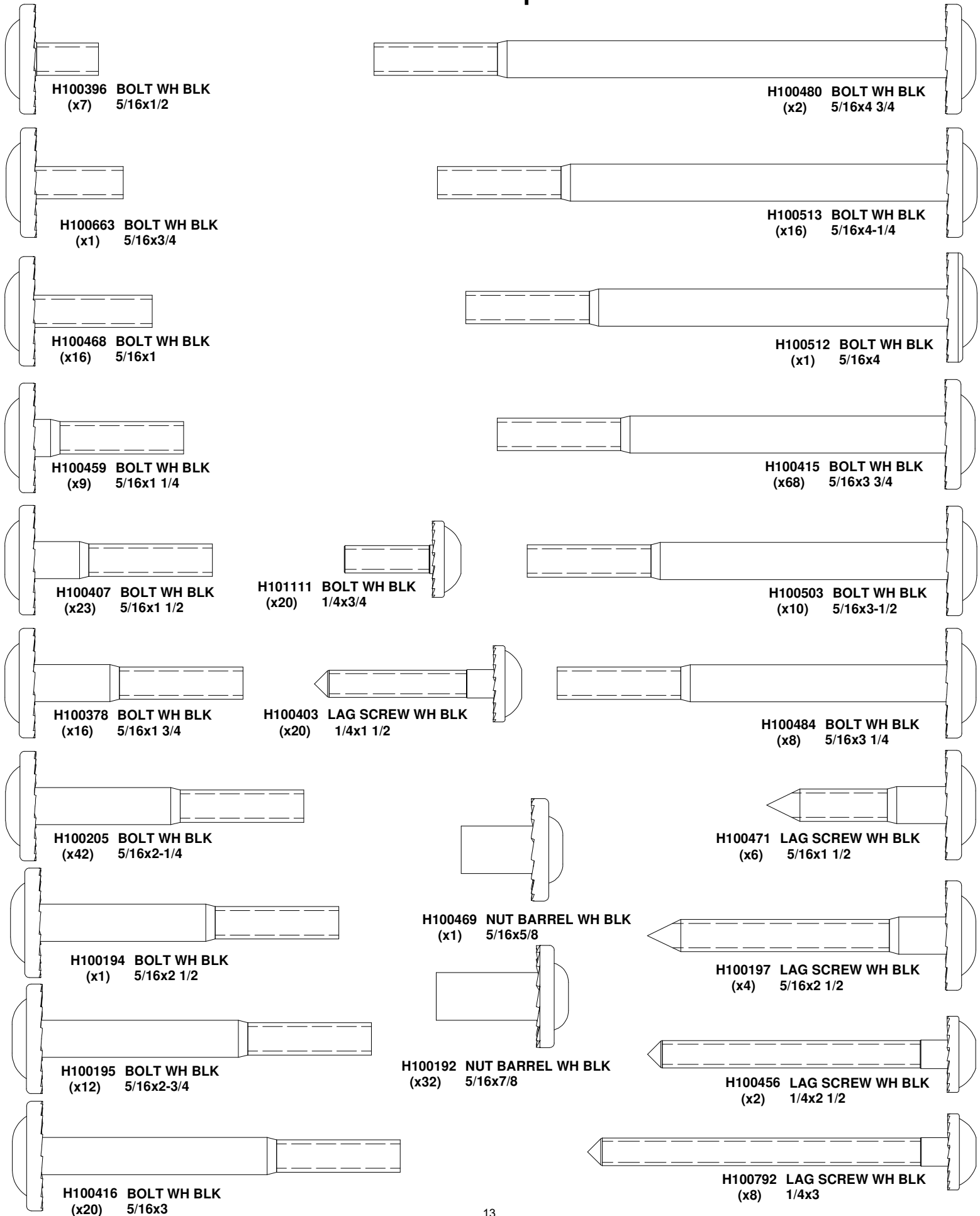

# Owner's Manual - Parts Identification

## Hardware Components

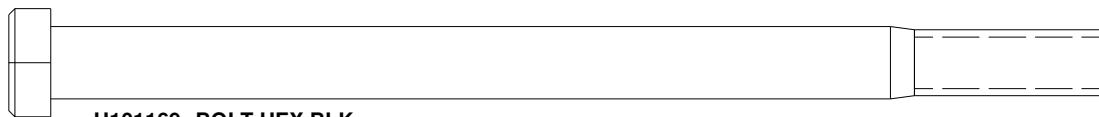

**H101169 BOLT HEX BLK**  
(x12) 3/8x5-1/2

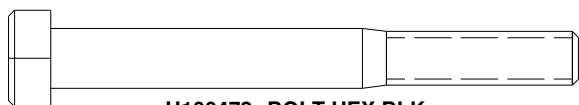

**H100472 BOLT HEX BLK**  
(x2) 5/16x2 3/4

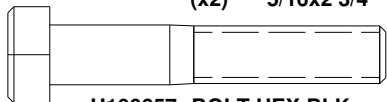

**H100657 BOLT HEX BLK**  
(x4) 5/16x1 3/4

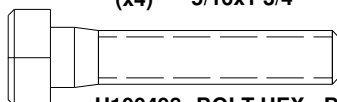

**H100498 BOLT HEX - BLK**  
(x4) 5/16x1 1/2

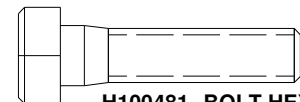

**H100481 BOLT HEX BLK**  
(x4) 5/16x1 1/4

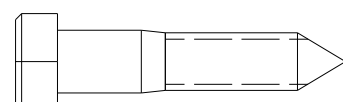

**H100659 LAG SCREW BLK**  
(x8) 5/16x1 1/2

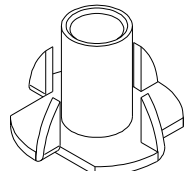

**H100379 T-NUT BLK**  
(x232) 5/16

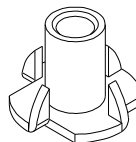

**H100398 T-NUT BLK**  
(x20) 1/4

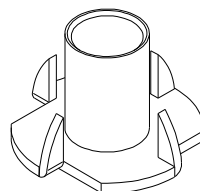

**H101168 T-NUT BLK**  
(x12) 3/8

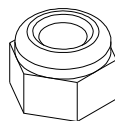

**H100479 NUT LOCK BLK**  
(x2) 5/16

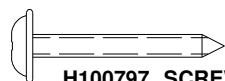

**H100797 SCREW PWH BLK**  
(x46) 8x1

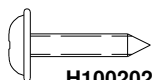

**H100202 SCREW PWH BLK**  
(x10) 8x5/8

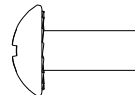

**H101272 NUT BARREL PTH BLK**  
(x6) 8x32

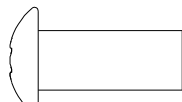

**H100831 NUT BARREL PTH BLK**  
(x4) 1/4x3/4

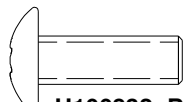

**H100832 BOLT PTH BLK (with LOCTITE)**  
(x4) 1/4x3/4

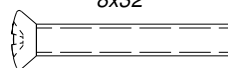

**H100806 SCREW POH BLK**  
(x6) 8/32x1 1/8



**H100382 SCREW PFH BLK**  
(x10) 8x1 3/4



**H100391 SCREW PFH BLK**  
(x46) 8x2

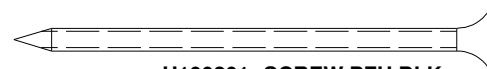

**H100201 SCREW PFH BLK**  
(x26) 8x2-1/2

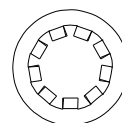

**H100473 WASHER LOCK INT BLK**  
(x22) 8x15

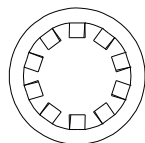

**H101166 WASHER LOCK INT BLK**  
(x12) 10x18

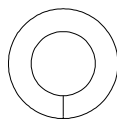

**H100477 WASHER SPLIT BLK**  
(x20) 5/16

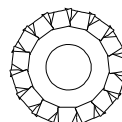

**H100405 WASHER LOCK EXT BLK**  
(x10) 6x15

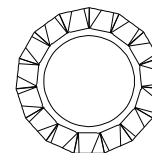

**H100199 WASHER LOCK EXT BLK**  
(x19) 12x19

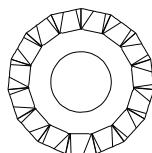

**H100198 WASHER LOCK EXT BLK**  
(x181) 8x19

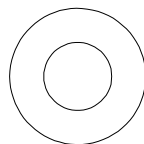

**H100474 WASHER FLAT BLK**  
(x2) 9x18

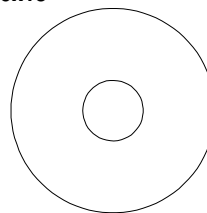

**H100478 WASHER FLAT BLK**  
(x22) 8x27

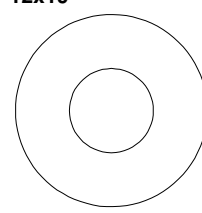

**H101167 WASHER FLAT BLK**  
(x12) 11x25

# Owner's Manual - Parts Identification

## Accessory Components (Not to Scale)



**A4M01126**  
(x1) **26" WEB SWING**



**A4M02256**  
(x4) **CHAIN BLACK 51.25"**



**A6P00595**  
(x2) **SWING SEAT GREY 22"**

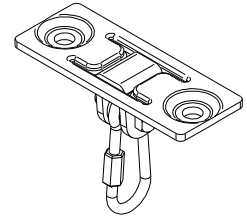

**A4M02171**  
(x6) **SWING HANGER**

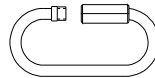

**A4M00633**  
(x4) **QUICK LINK BLK**

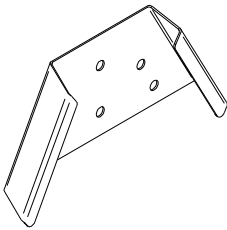

**A4M01782**  
(x1) **A-FRAME BRACKET**

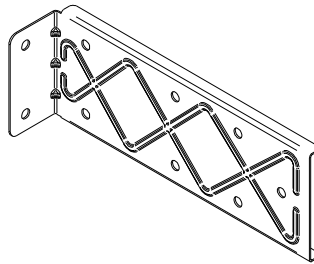

**A4M01679**  
(x2) **EXTENDED SWING BEAM BRACKET**



**A4M03403** **BYD ID TAG LARGE**  
(x1)

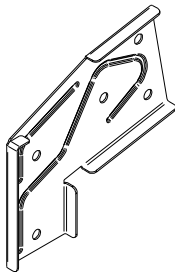

**A4M00617**  
(x1) **SWING BEAM EXTENSION BRACKET-LEFT**

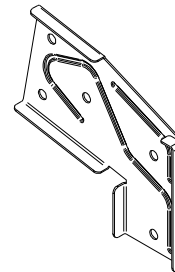

**A4M00618**  
(x1) **SWING BEAM EXTENSION BRACKET-RIGHT**



**H100147**  
(x1) **T-30 TORX BIT**

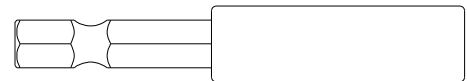

**H101100**  
(x1) **MAGNETIC DRIVER**

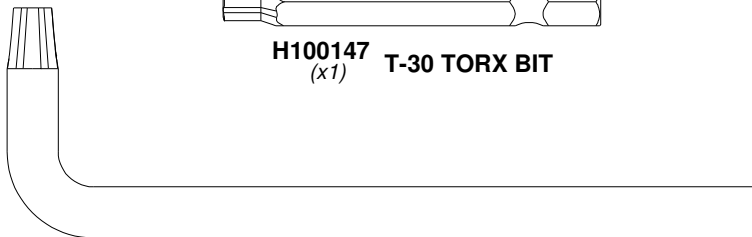

**H100114**  
(x1) **T-30 TORX WRENCH**

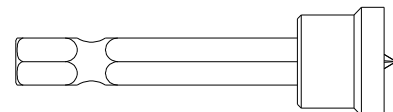

**H100764**  
(x1) **SCREW SETTER**

# Owner's Manual - Parts Identification

## Accessory Components (Not to Scale)

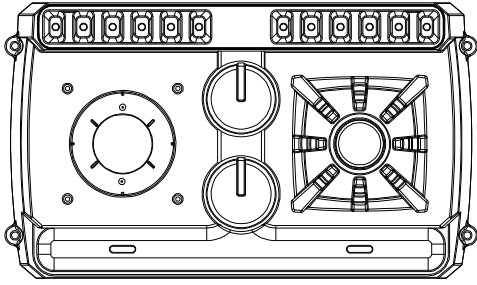

**A6P00335**  
(x1) **STOVE BASE**

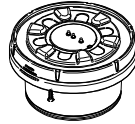

**A6P00330**  
(x1) **INDUCTIVE BURNER KIT**

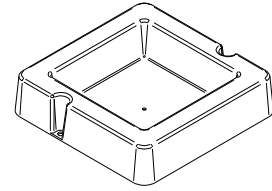

**A6P00032**  
(x1) **SURFACE MOUNT BASIN**



**A6P00410**  
(x1) **PICKET PAL**

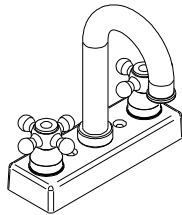

**A6P00024**  
(x1) **FAUCET KIT**



**A6P00592**  
(x5) **GREY HC ROCK #1**

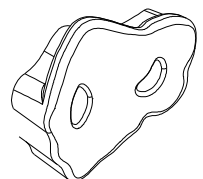

**A6P00593**  
(x5) **GREY HC ROCK #2**



**A6P00340**  
(x1) **LADLE**



**A6P00339**  
(x1) **SPATULA**

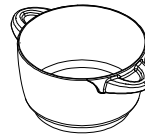

**A6P00336**  
(x1) **BOIL POT**



**A6P00338**  
(x1) **FRY PAN**

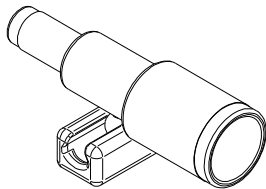

**A6P00596**  
(x1) **TELESCOPE GREY**



**A6P00331**  
(x1) **BLENDER**



**A6P00337**  
(x2) **POT/PAN LID**

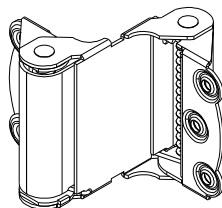

**A4M01089**  
(x2) **SPRING HINGE**



**A4M02635**  
(x1) **METAL ANGLE BRACE**

# Owner's Manual - Parts Identification

## Accessory Components (Not to Scale)

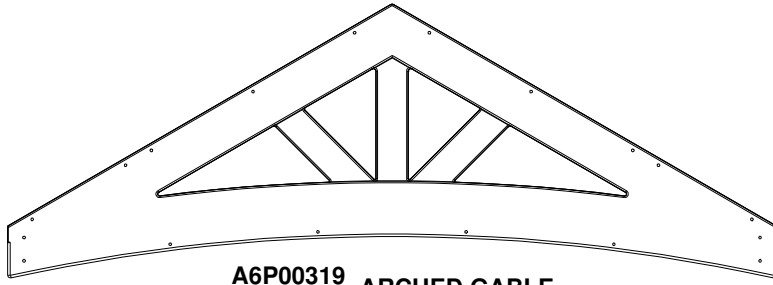

**A6P00319**  
(x2) **ARCHED GABLE**

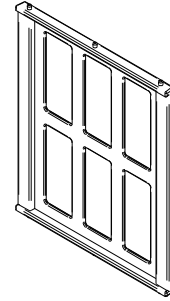

**A100373**  
(x6) **BAY WINDOW PANEL**

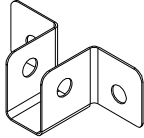

**A4M02606**  
(x1) **JOIST HANGER 90°**



**A4M02250**  
(x2) **HAND GRIP GREY 816 C/C**

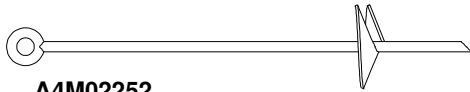

**A4M02252**  
(x10) **AUGER GROUND STAKE**



**A4M02251**  
(x2) **LADDER RUNG 578 GREY**

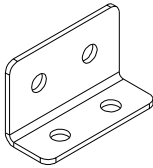

**A4M00855**  
(x5) **L BRACKET**  
**32x51x82**

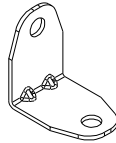

**A4M01047**  
(x10) **L BRACKET**  
**2.5x38x55x55**

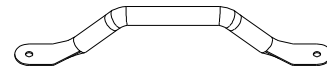

**A4M02249**  
(x6) **HAND GRIP METAL GREY 381 C/C**

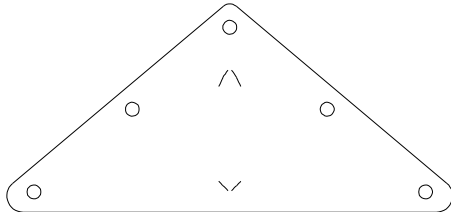

**A4M00614**  
(x2) **TRIANGLE**  
**PLATE 100° 5**  
**HOLE**

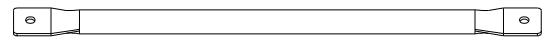

**A4M04648**  
(x8) **METAL RUNG**  
**GREY**

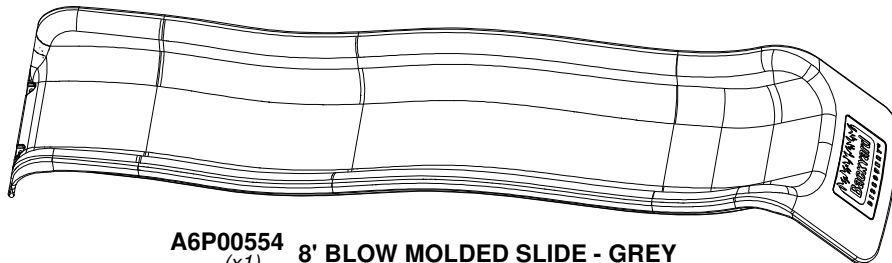

**A6P00554**  
(x1) **8' BLOW MOLDED SLIDE - GREY**

# PRE-ASSEMBLY STEP 1 - SORTING PARTS

It is critical for ease of assembly that you take the time to sort and organize the wood and hardware.

---

## WOOD PARTS:

- Organize wood parts by the three-digit, alpha-numeric number stamped on each board (ex. P01).
- If there are multiple boards with the same stamped number, stack those pieces together.
- Stamps can be found on the flat surface of the boards or on the end of the boards.
- Allow yourself plenty of room - the wood pieces can take up a significant amount of space.

**NOTE: CARTONS ARE NOT ORGANIZED BY BOARD NUMBER.**

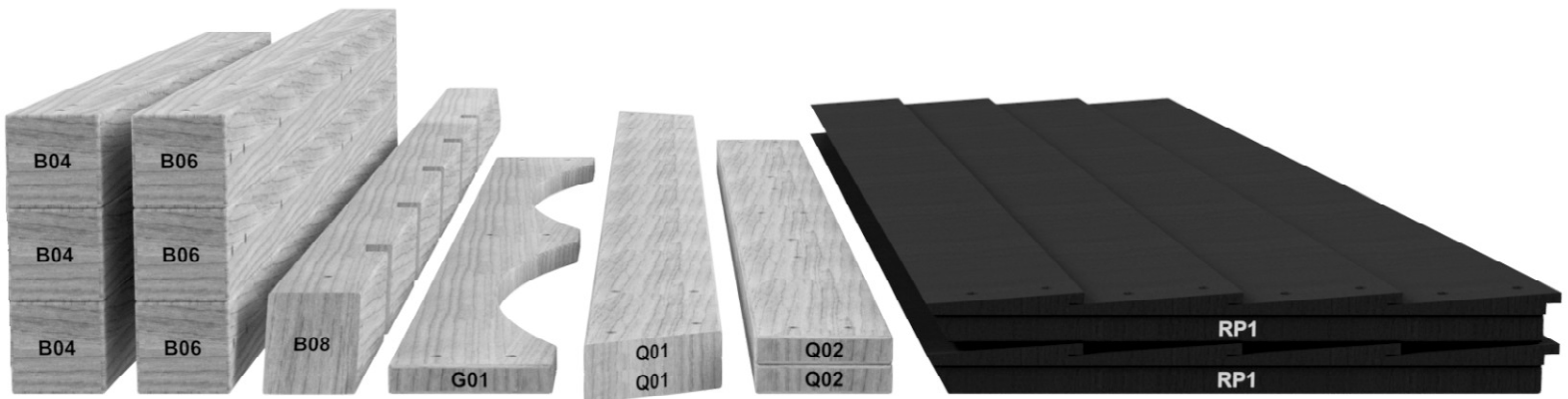

---

## HARDWARE PARTS:

- We recommend that you have a separate table to organize the hardware.
- Hardware bags are printed with a seven-digit, alpha-numeric part number.
- You can organize your hardware by part number or group by hardware type (i.e. bolts, nuts, etc.).
- During assembly you only need to reference the last four digits of the number.

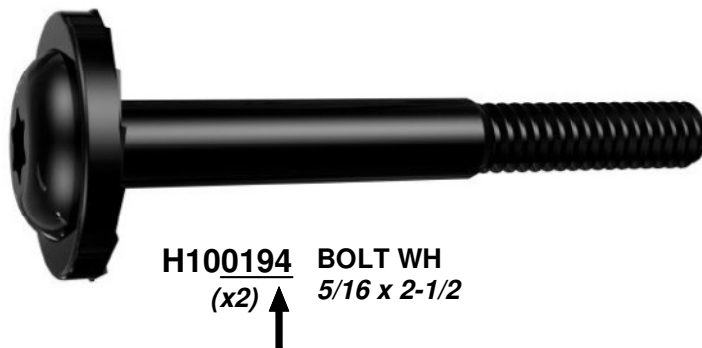

# PRE-ASSEMBLY STEP 2 - TOOLS REQUIRED



**Cordless Drill or  
Electric Drill**



**Drill Attachments:  
Phillips Head**



**1/8", 3/16", 3/8" & 7/16"  
Drill Bits**



**Phillips Screw Driver**



**Open End Wrenches 1/2" & 9/16"**



**3/8" Drive Ratchet, 1/2" &  
9/16" STD Sockets 1/2" & 9/16" Deep  
Sockets**



**Claw Hammer**



**Rubber Mallet - Optional**



**Tape Measure**

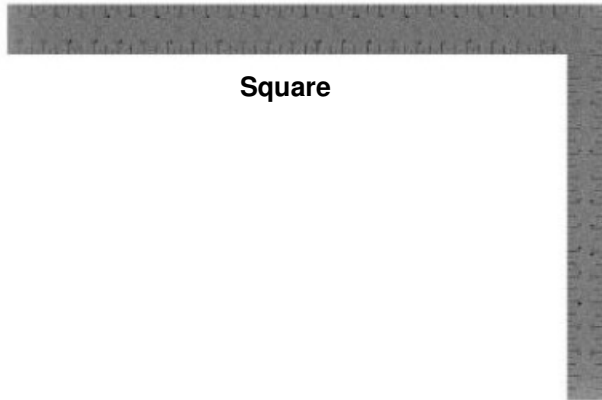

**Square**





**Level 24"**

# PRE-ASSEMBLY STEP 3 - CHOOSE YOUR ASSEMBLY METHOD



There are several types of assembly instructions available to you.

1. Printed Assembly Manual included with your set
2. BILT APP - 3D interactive instructions
3. Combination of the Printed Manual and BILT APP (Note: Step numbers can differ between the two methods)

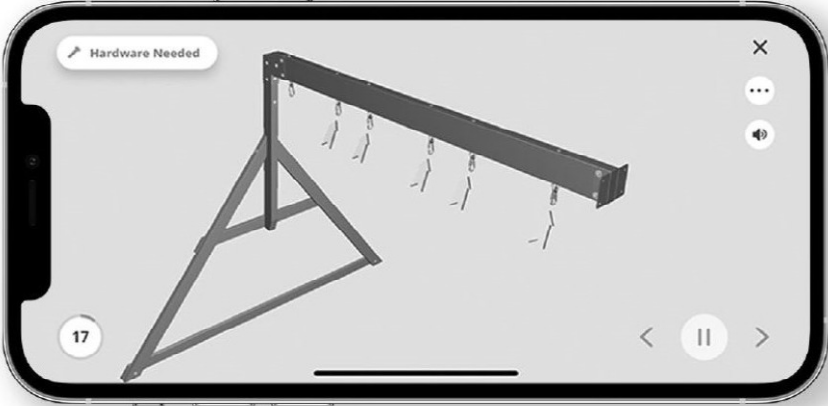

## Scan for easy 3D instructions

Download the BILT app  
before you begin



# ELECTRONICS SAFETY WARNING

**Note:**

This equipment has been tested and found to comply with the limits for a Class B digital device, pursuant to part 15 of the FCC Rules. These limits are designed to provide reasonable protection against harmful interference in a residential installation. This equipment generates, uses and can radiate radio frequency energy and, if not installed and used in accordance with the instructions, may cause harmful interference to radio communications. However, there is no guarantee that interference will not occur in a particular installation. If this equipment does cause harmful interference to radio or television reception, which can be determined by turning the equipment off and on, the user is encouraged to try to correct the interference by one or more of the following measures:

- Reorient or relocate the receiving antenna.
- Increase the separation between the equipment and receiver.
- Connect the equipment into an outlet on a circuit different from that to which the receiver is connected.
- Consult the dealer or an experienced radio/TV technician for help

Caution: Changes or modifications not expressly approved by the party responsible for compliance could void the user's authority to operate the equipment.

# STEP 1 - BAY WINDOW ASSEMBLY

QTY	PART NUMBER	DESCRIPTION
4	H100200	SCREW PFH 8x1-1/2" BLK
4	H100385	SCREW PFH 8x1" BLK

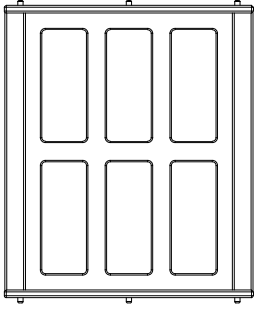

**A100373**  
(3) **BAY WINDOW PANEL**



**J04 BAY WINDOW SIDE - W4L21348**  
(x2) 1"x1 7/8"x18 1/4" (24x48x464)



**K02 BAY WINDOW HEADER - W4L21347**  
(x2) 5/8"x5 1/4"x47 1/8" (16x134x1197)

**REPEAT THIS STEP TWICE.**

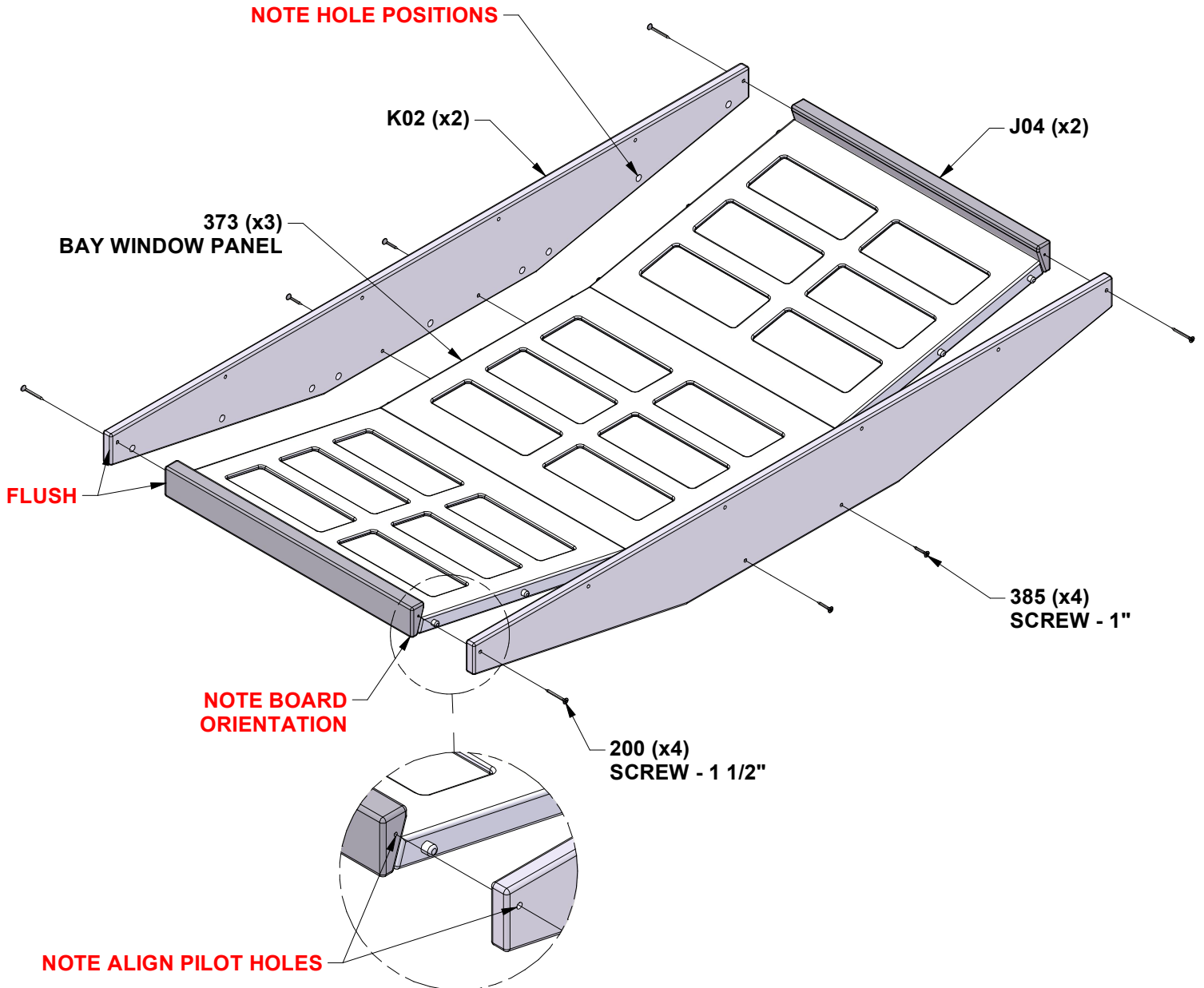

# STEP 1 - CROWS NEST DECK ASSEMBLY

QTY	PART NUMBER	DESCRIPTION
4	H100201	SCREW PFH 8x2-1/2" BLK
4	H100379	T-NUT 5/16" BLK

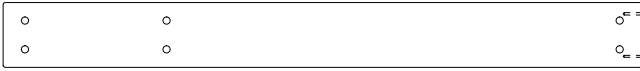

**E03 CROWS NEST FLOOR RAIL - W4L21340**  
 (x2) 1 3/8"x3 3/8"x33 1/4" (36x86x846)



**H18 CROWS NEST FLOOR RAIL - W4L21342**  
 (x1) 1"x3 3/8"x27" (24x86x686)

**INSTALL T-NUTS IN WOOD FIRST.  
 ALIGN PILOT HOLES.**

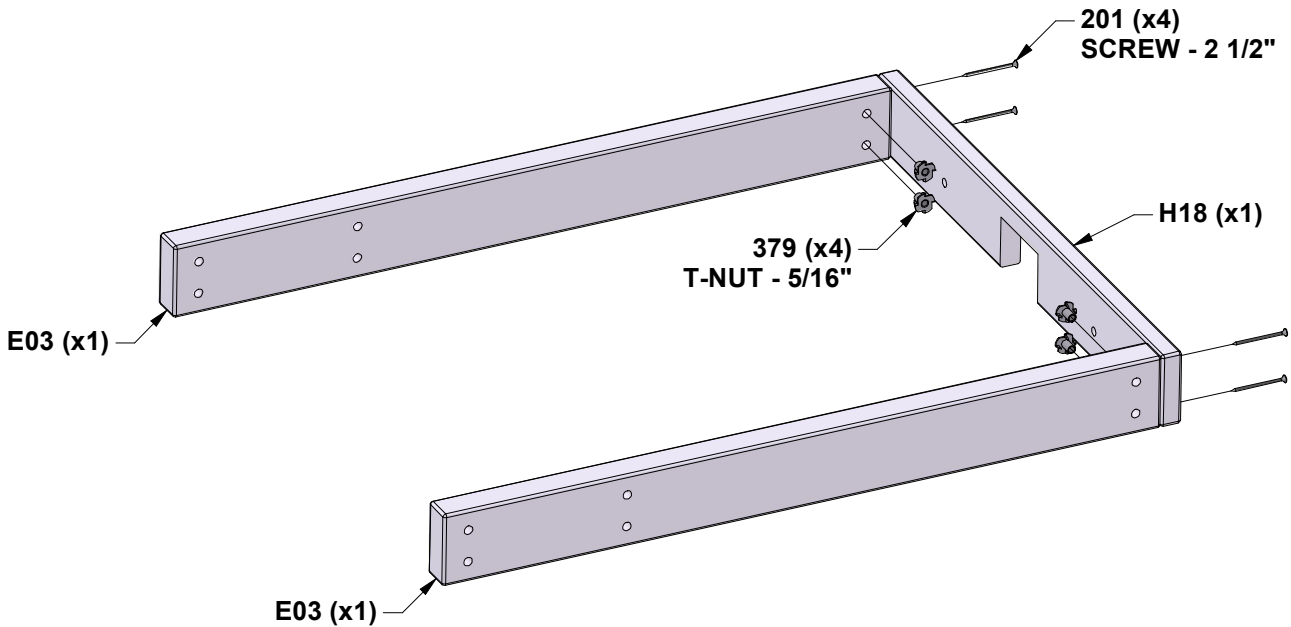

# STEP 2 - CROWS NEST DECK ASSEMBLY

QTY	PART NUMBER	DESCRIPTION
2	H100205	BOLT WH 5/16x2-1/4" BLK
2	H100198	WASHER LOCK EXT 8x19 BLK
2	H100379	T-NUT 5/16" BLK

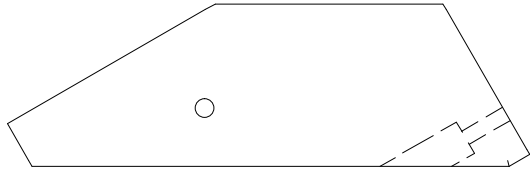

**E04 CROWS NEST DECK BRACE - W4L21341**  
 (x2) 1 7/16"x3 3/8"x10 7/8" (36x86x276)

## INSTALL T-NUTS IN WOOD FIRST

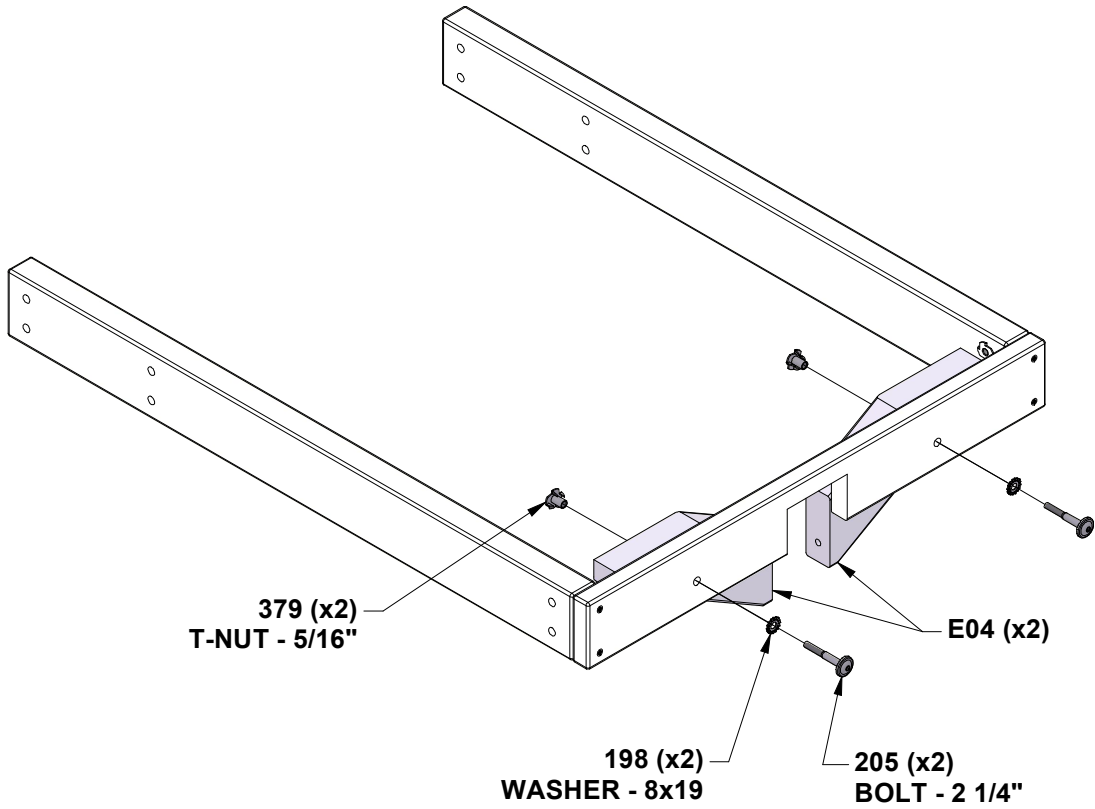
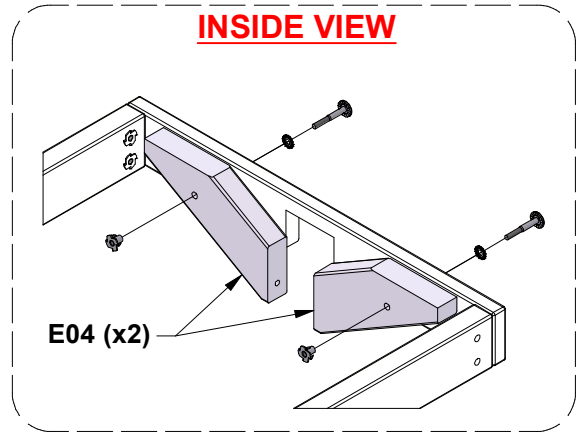

# STEP 3 - CROWS NEST NEST DECK ASSEMBLY

QTY	PART NUMBER	DESCRIPTION
30	H100200	SCREW PFH 8x1-1/2" BLK



**L03 CROWS NEST FLOOR BOARD - W4L21344**  
(x6) 5/8"x4 3/8"x27" (16x112x686)



**K03 CROWS NEST FLOOR BOARD - W4L21346**  
(x1) 5/8"x5 1/4"x27" (16x134x686)

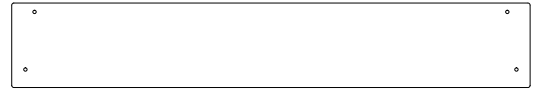

**L04 CROWS NEST FLOOR BOARD - W4L21345**  
(x1) 5/8"x4 3/8"x27" (16x112x686)

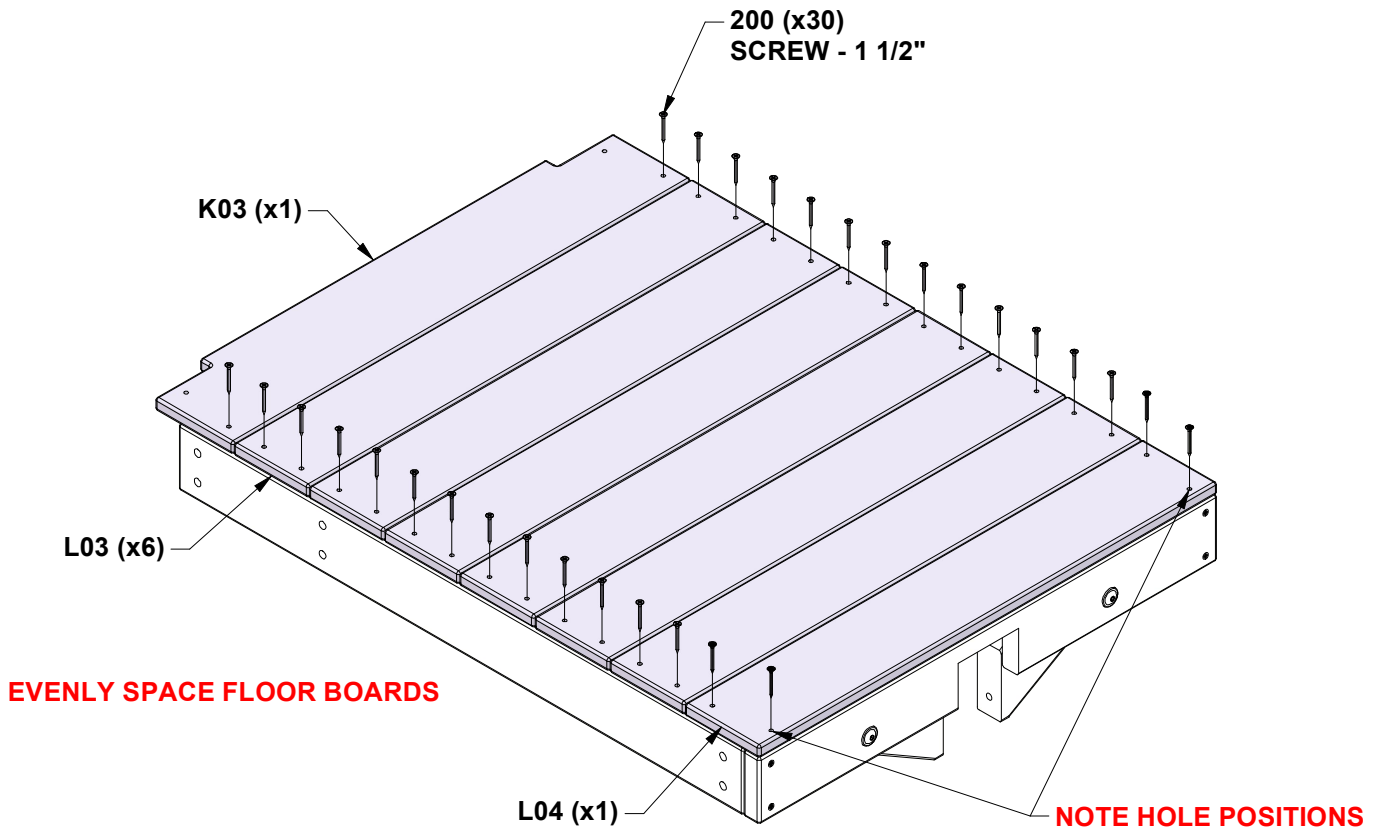
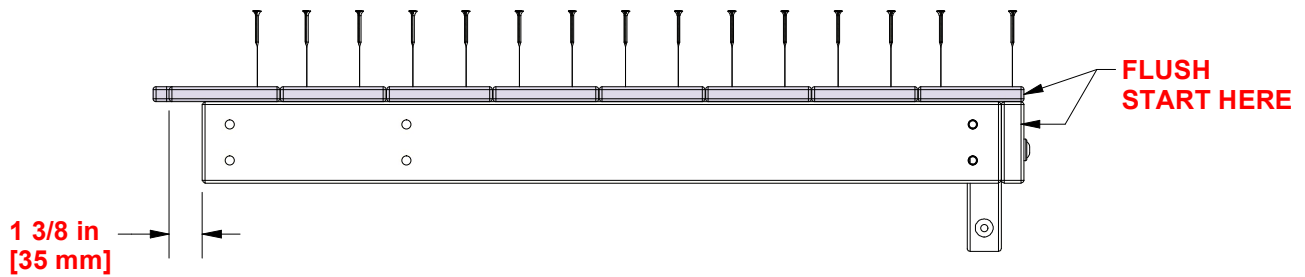

# STEP 4 - CROWS NEST DECK ASSEMBLY

QTY	PART NUMBER	DESCRIPTION
2	H100387	SCREW PFH 8x1-1/4" BLK



**H19 CROWS NEST FLOOR SUPPORT - W4L21343**  
 (x1) 1"x3 3/8"x24 1/8" (24x86x614)

**MARK LOCATIONS SHOWN. USING A 3/16" (5 mm) DRILL BIT, DRILL (2) PILOT HOLES THROUGH DECK.**

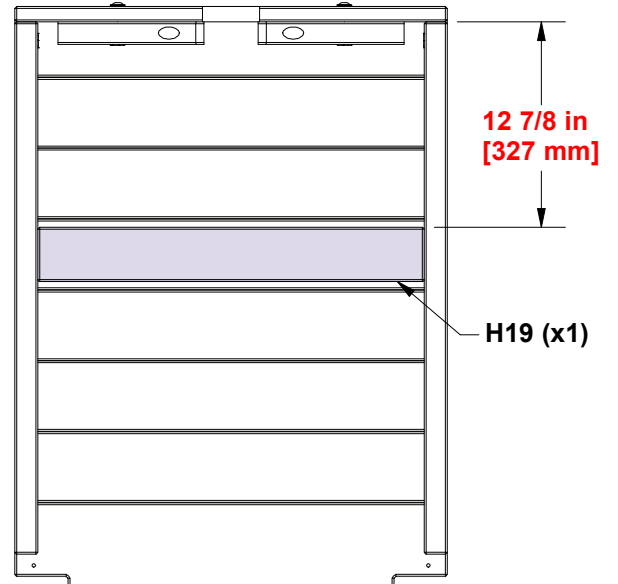
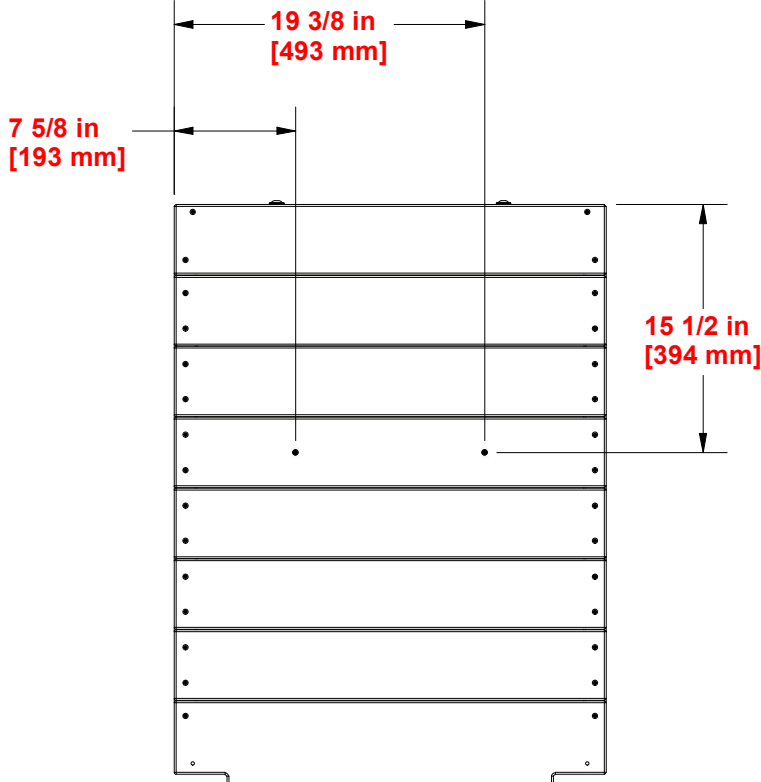
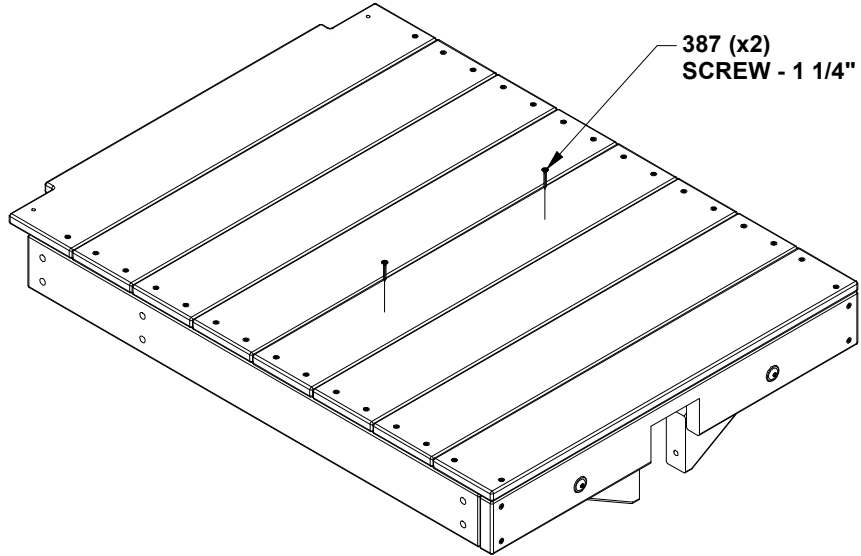

# STEP 1 - LADDER ASSEMBLY

QTY	PART NUMBER	DESCRIPTION
8	H100201	SCREW PFH 8x2-1/2 BLK

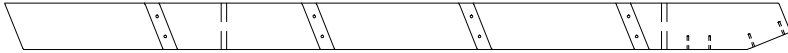

**E12 LEFT UPRIGHT - W4L21321**  
(x1) 1 3/8"x3 3/8"x57 3/8" (36x86x1456)



**H26 LADDER RUNG - W4L21323**  
(x4) 1"x3 3/8"x21 3/4" (24x86x554)

## ALIGN PILOT HOLES.

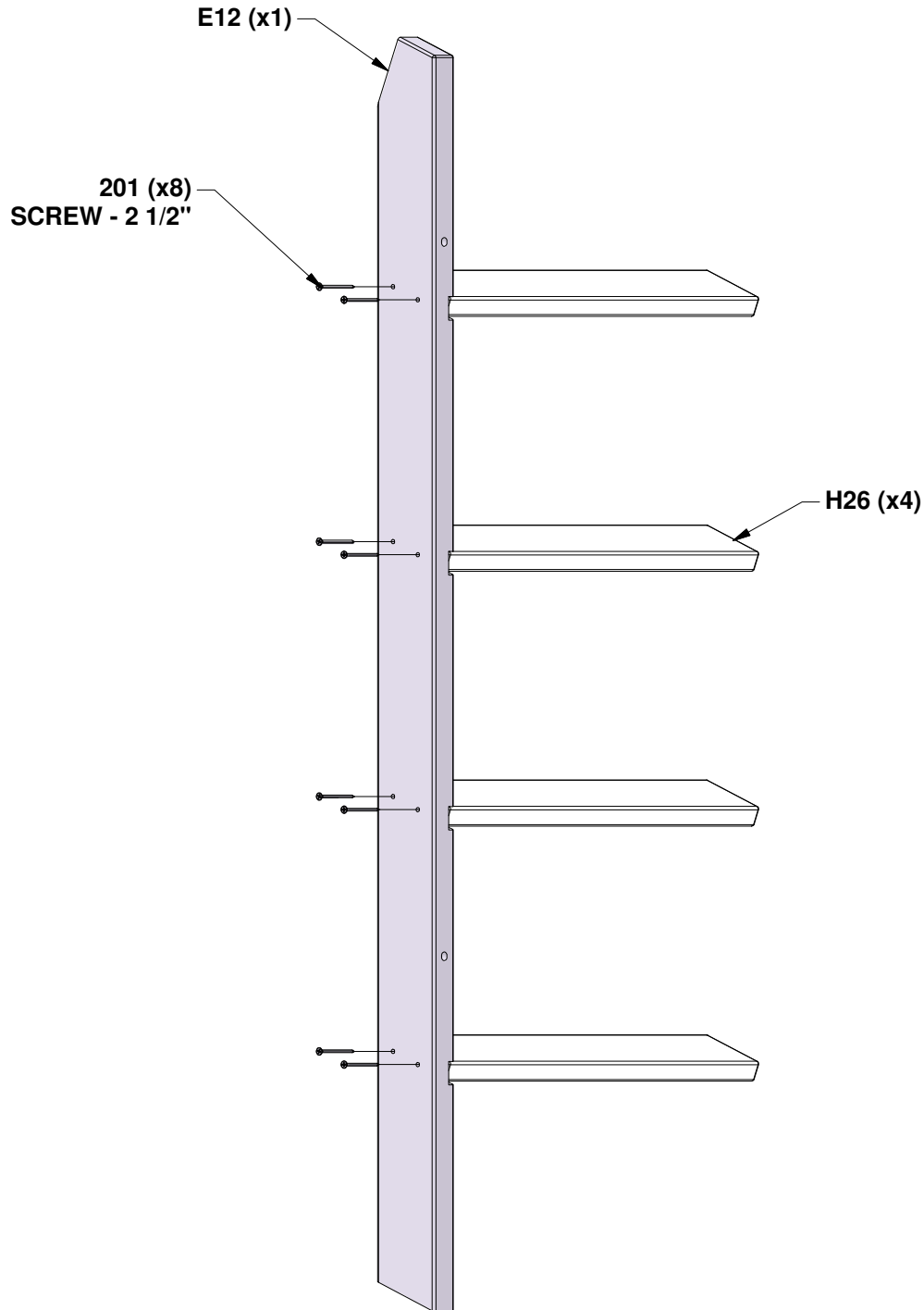

# STEP 2 - LADDER ASSEMBLY

QTY	PART NUMBER	DESCRIPTION
8	H100201	SCREW PFH 8x2-1/2 BLK



**E11 RIGHT UPRIGHT - W4L21322**  
**(x1) 1 3/8"x3 3/8"x57 3/8" (36x86x1456)**

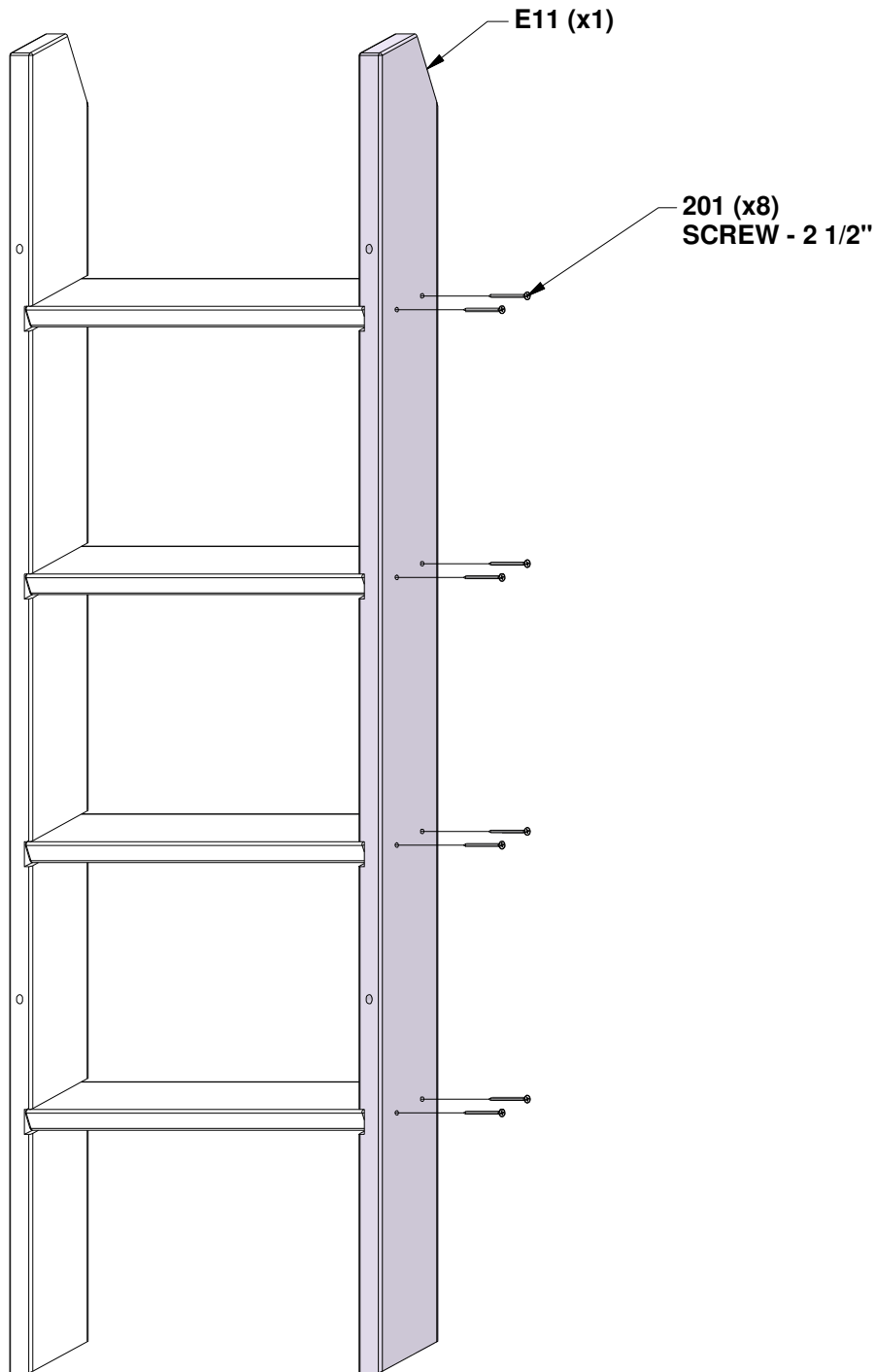

# STEP 3 - LADDER ASSEMBLY

QTY	PART NUMBER	DESCRIPTION
4	H100200	SCREW PFH 8x1-1/2 BLK
4	H100391	SCREW PFH 8x2 BLK



**M12 REAR SUPPORT - W4L21324**  
(x1) 5/8"x3 3/8"x23 7/8" (16x86x606)



**H25 ATTACHMENT BOARD - W4L21325**  
(x1) 1"x3 3/8"x23 7/8" (24x86x606)

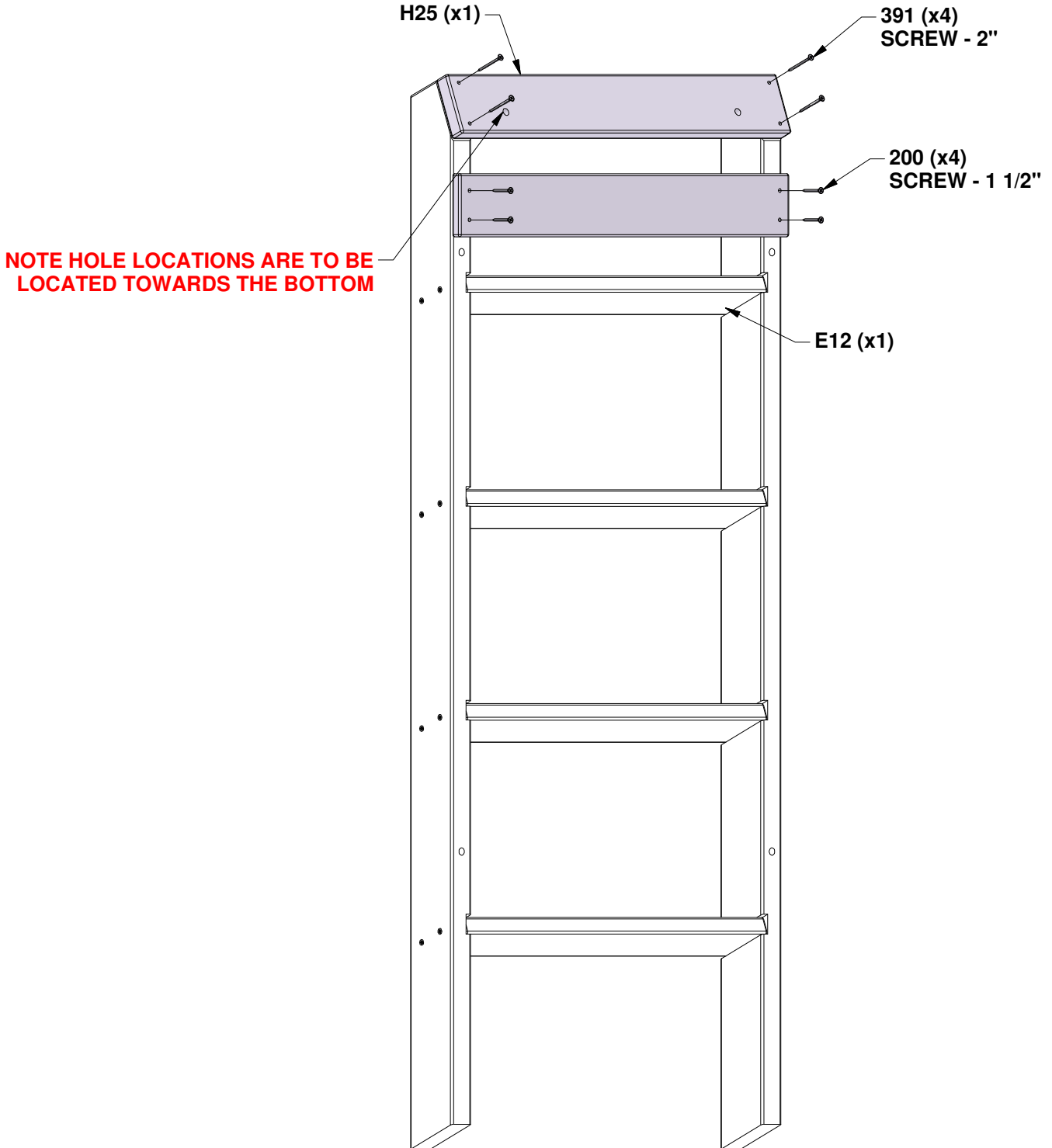

# STEP 4 - LADDER ASSEMBLY

QTY	PART NUMBER	DESCRIPTION
4	H100503	BOLT WH 5/16x3 1/2 BLK
4	H100379	T-NUT 5/16 BLK



## INSTALL T-NUTS IN WOOD FIRST

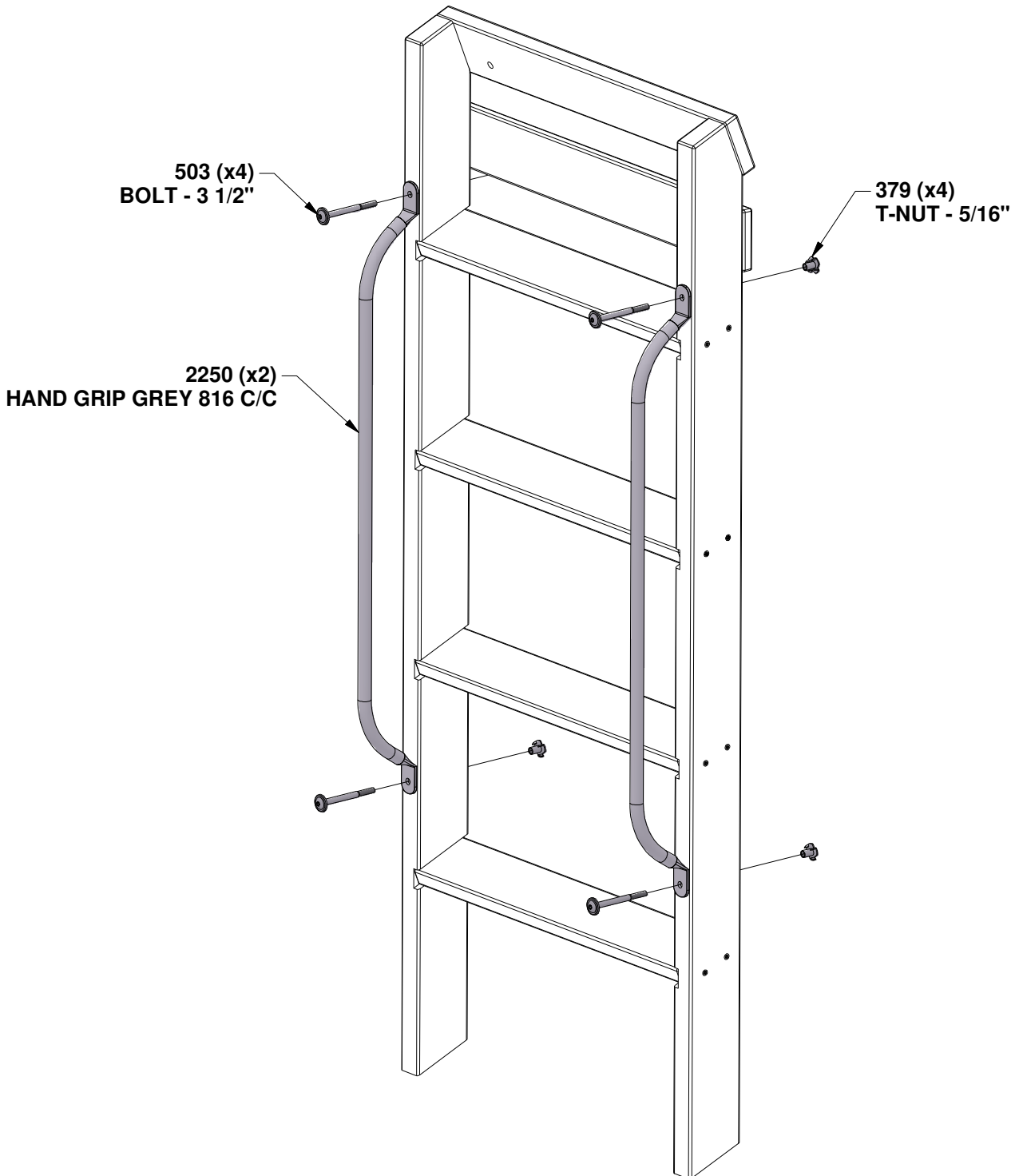

# STEP 1 - MONKEY BARS

QTY	PART NUMBER	DESCRIPTION
2	H100205	BOLT WH 5/16x2-1/4 BLK
6	H100379	T-NUT 5/16 BLK
8	H100403	LAG SCREW WH 1/4x1-1/2 BLK
6	H100407	BOLT WH 5/16x1 1/2 BLK
2	H100478	WASHER FLAT 8x27 BLK
2	H100479	NUT LOCK 5/16 BLK



**E74 MONKEY BAR RAIL - W4L21422**  
(x2) 1 3/8"x3 3/8"x77 1/8" (36x86x1959)

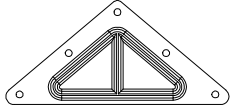

**A4M00614 TRIANGLE PLATE**  
(x2) 100° 5 HOLE

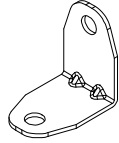

**A4M01047 L BRACKET**  
(x4) 2.5x38x55x55

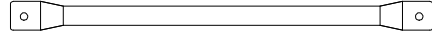

**A4M04648 METAL RUNG**  
(x4) GREY

## INSTALL T-NUTS IN WOOD FIRST

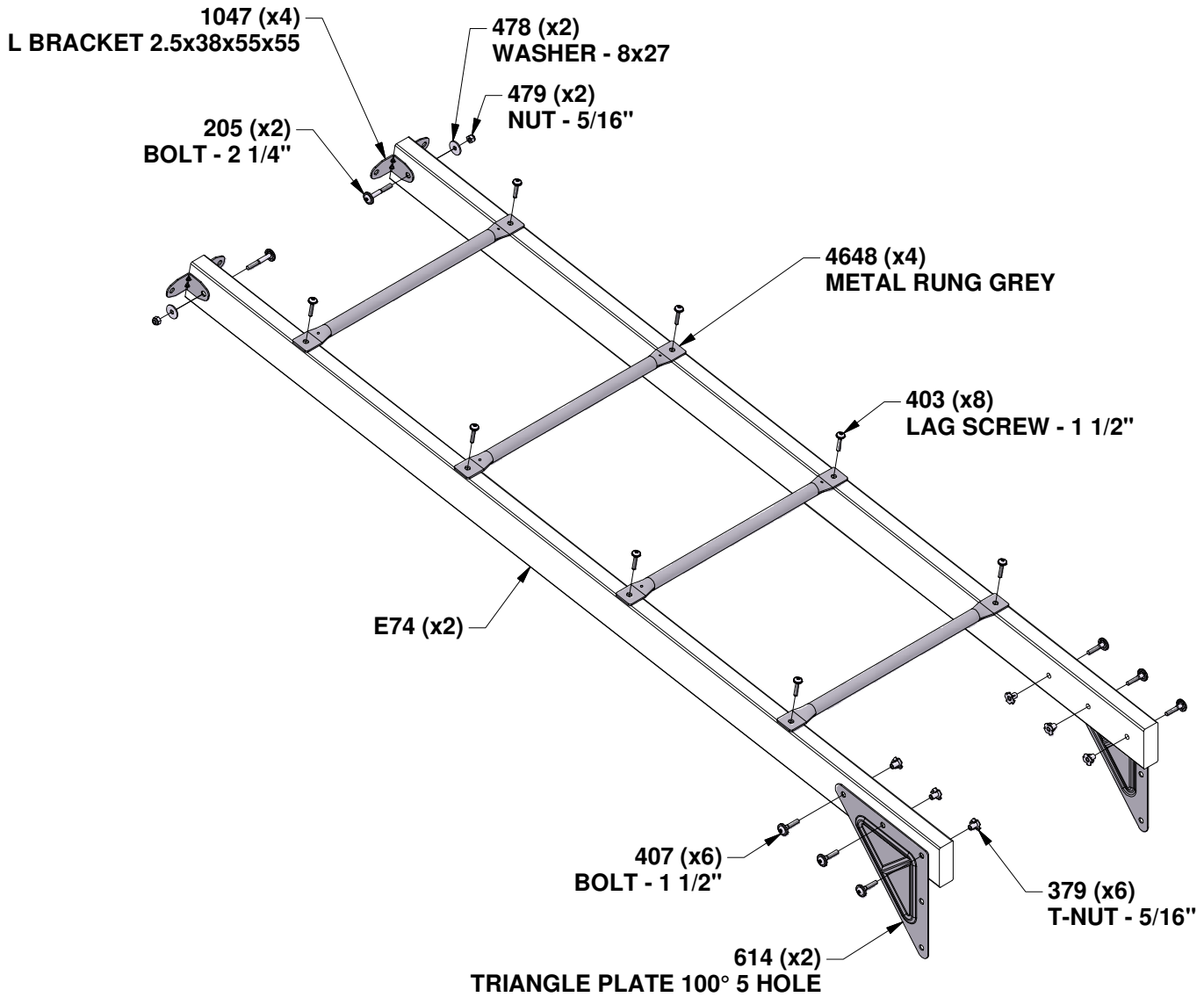

# STEP 2 - MONKEY BARS

QTY	PART NUMBER	DESCRIPTION
4	H100379	T-NUT 5/16 BLK
4	H100407	BOLT WH 5/16x1 1/2 BLK



**E13 MONKEY BAR UPRIGHT - W4L21419**  
(x2) 1 3/8"x3 3/8"x77 3/8" (36x86x1966)

## INSTALL T-NUTS IN WOOD FIRST

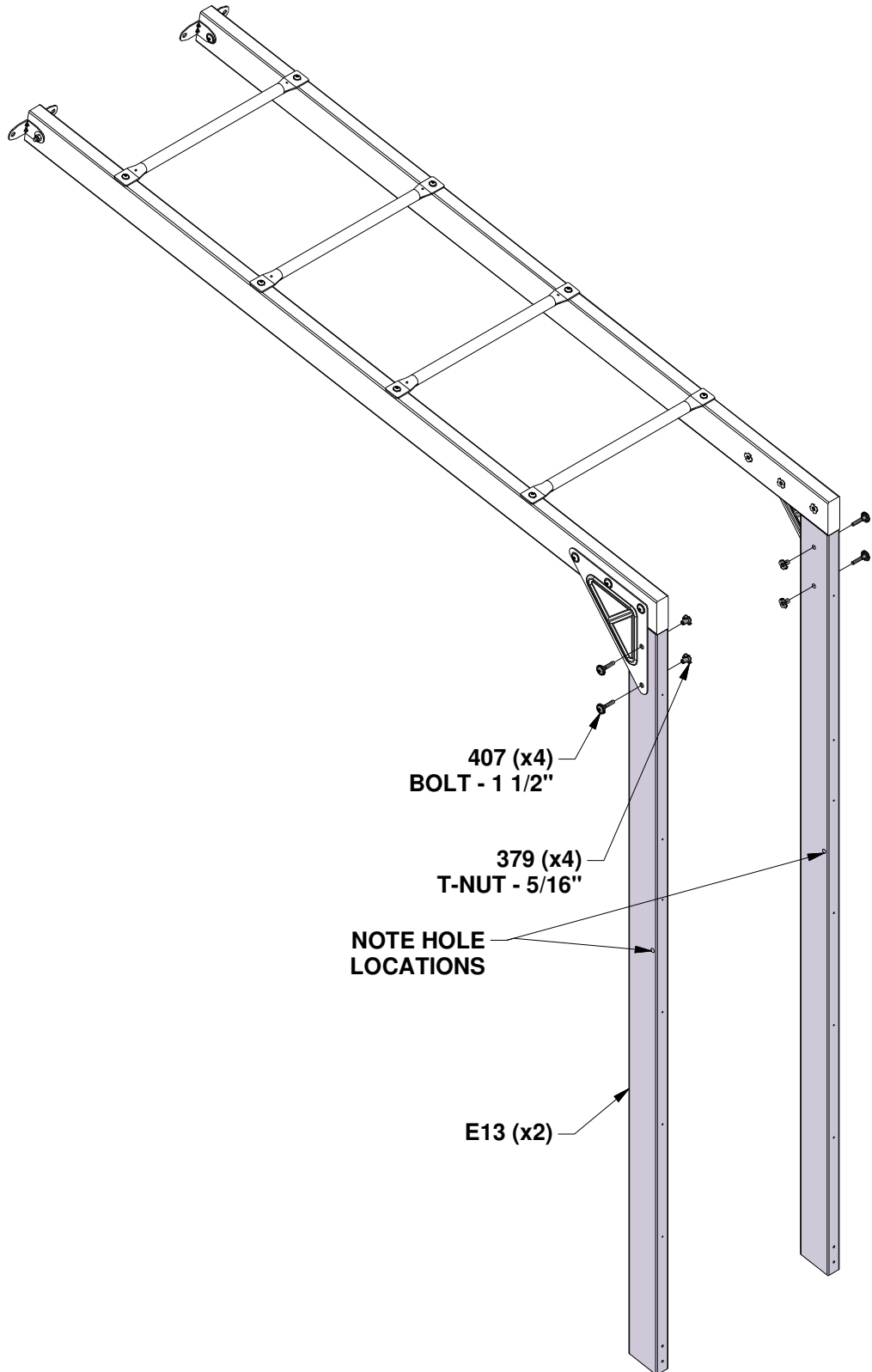

# STEP 3 - MONKEY BARS

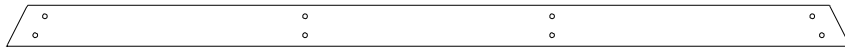

**H82 MONKEY BAR GROUND BOARD - W4L21421**  
(x1) 1"x3 3/8"x70 3/8" (24x86x1786)



**H81 MONKEY BAR BRACE - W4L21420**  
(x2) 1"x3 3/8"x51 5/8" (24x86x1311)

QTY	PART NUMBER	DESCRIPTION
4	H100192	NUT BARREL WH 5/16x7/8 BLK
4	H100197	LAG SCREW WH 5/16x2-1/2 BLK
8	H100198	WASHER LOCK EXT 8x19 BLK
4	H100199	WASHER LOCK EXT 12x19 BLK
2	H100379	T-NUT 5/16 BLK
4	H100407	BOLT WH 5/16x1 1/2 BLK
2	H100472	BOLT HEX 5/16x2-3/4 BLK
2	H100473	WASHER LOCK INT 8x15 BLK
2	H100474	WASHER FLAT 9x18 BLK

## INSTALL T-NUTS IN WOOD FIRST

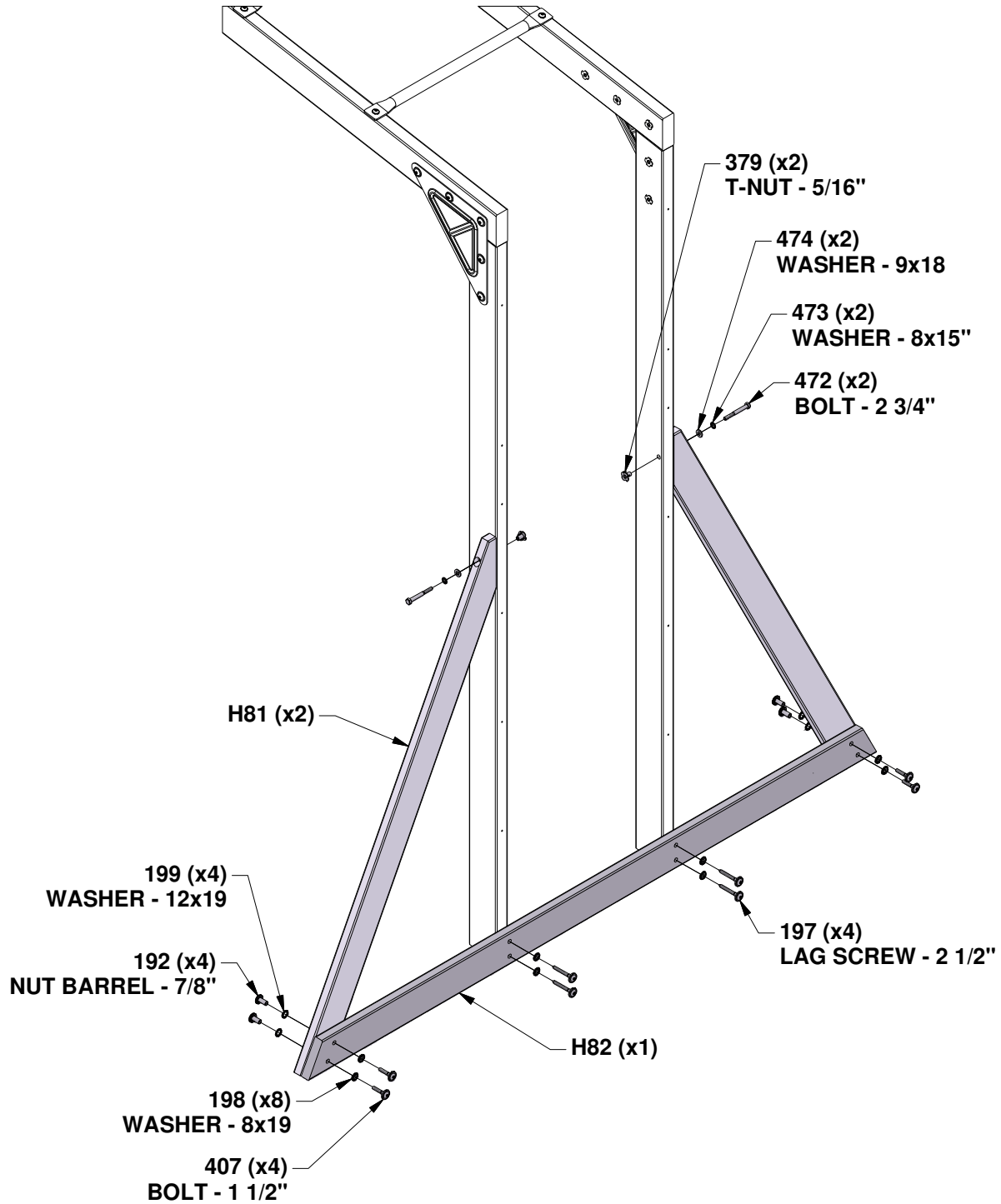

# STEP 4 - MONKEY BARS

QTY	PART NUMBER	DESCRIPTION
12	H100403	LAG SCREW WH 1/4x1-1/2 BLK



A4M02249 HAND GRIP METAL  
(x2) GREY 381 c/c

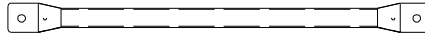

A4M04648 METAL RUNG GREY  
(x4)

## ALIGN PILOT HOLES

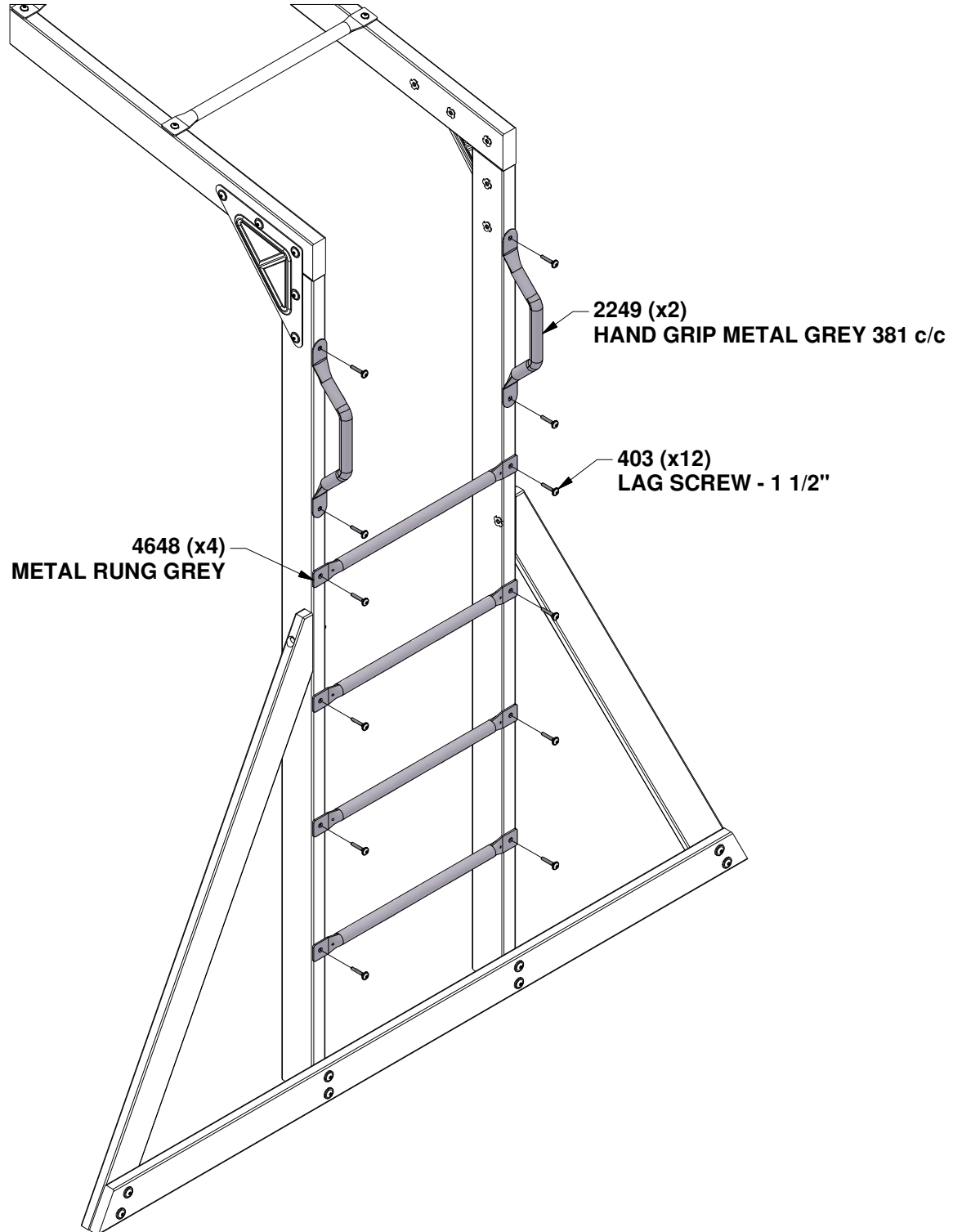

# STEP 1 - ROCK WALL

QTY	PART NUMBER	DESCRIPTION
20	H100398	T-NUT 1/4
20	H100473	WASHER LOCK INT 8x15 BLK
20	H101111	BOLT WH 1/4x3/4 BLK



**M15 ROCK BOARD - W4L21329**  
(x4) 5/8"x3 3/8"x33 1/4" (16x86x843)



**M16 ROCK BOARD - W4L21330**  
(x3) 5/8"x3 3/8"x33 1/4" (16x86x843)



**A6P00592 GREY HC ROCK #1**  
(x5)

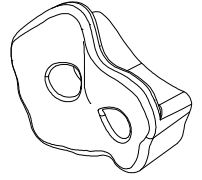

**A6P00593 GREY HC ROCK #2**  
(x5)

## INSTALL T-NUTS IN WOOD FIRST

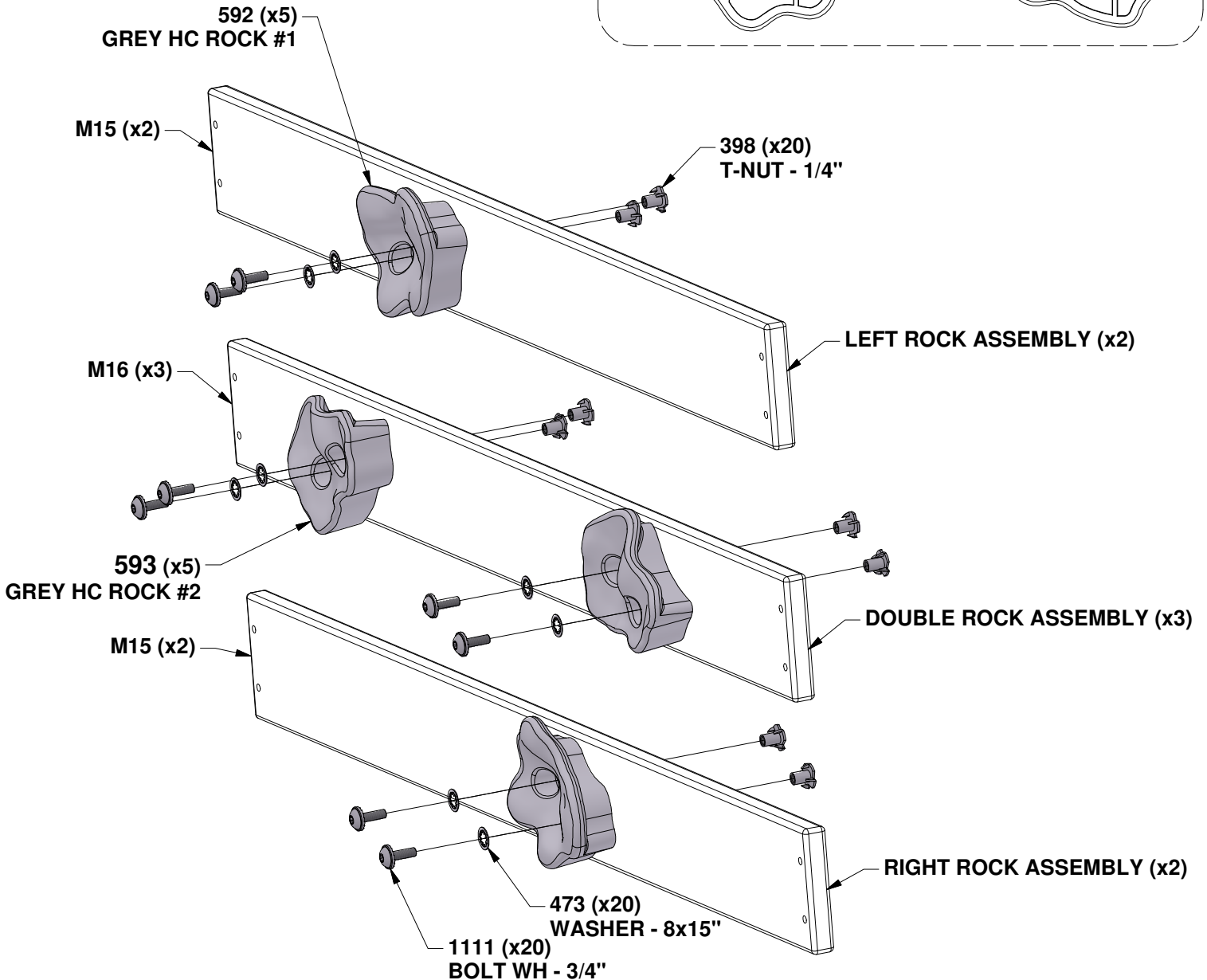
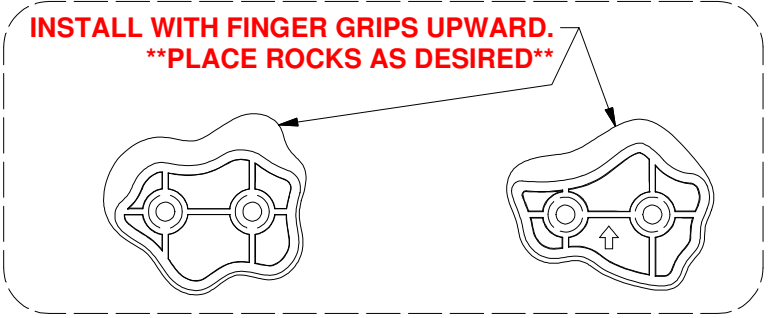

# STEP 2 - ROCK WALL

QTY	PART NUMBER	DESCRIPTION
66	H100200	SCREW PFH 8x1-1/2 BLK



LEFT ROCK ASSEMBLY (x2)



DOUBLE ROCK ASSEMBLY (x3)



RIGHT ROCK ASSEMBLY (x2)



E09 UPRIGHT - W4L21332  
(x2) 1 3/8"x3 3/8"x57 3/8" (36x86x1456)



M13 ROCK BOARD - W4L21328  
(x9) 5/8"x3 3/8"x33 1/4" (16x86x843)

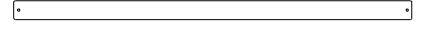

N04 ROCK WALL BOARD - W4L21327  
(x1) 5/8"x1 5/8"x33 1/4" (16x40x843)

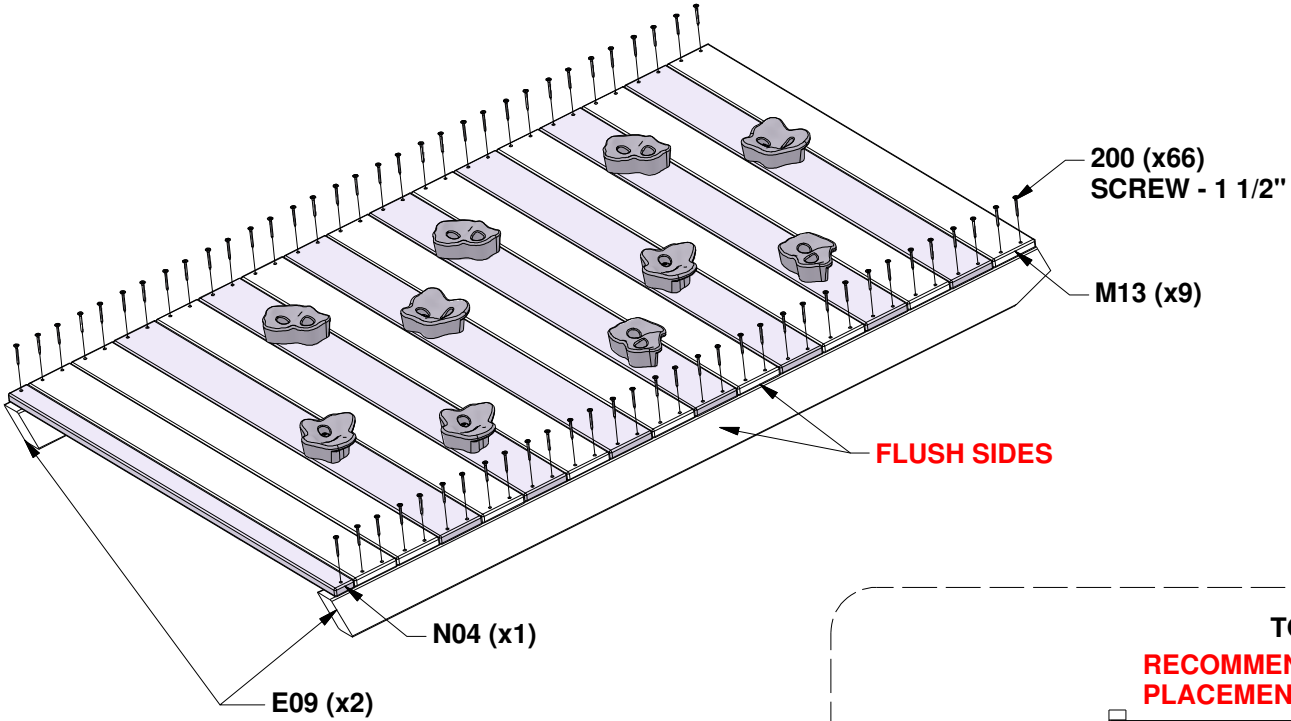

FLUSH SIDES

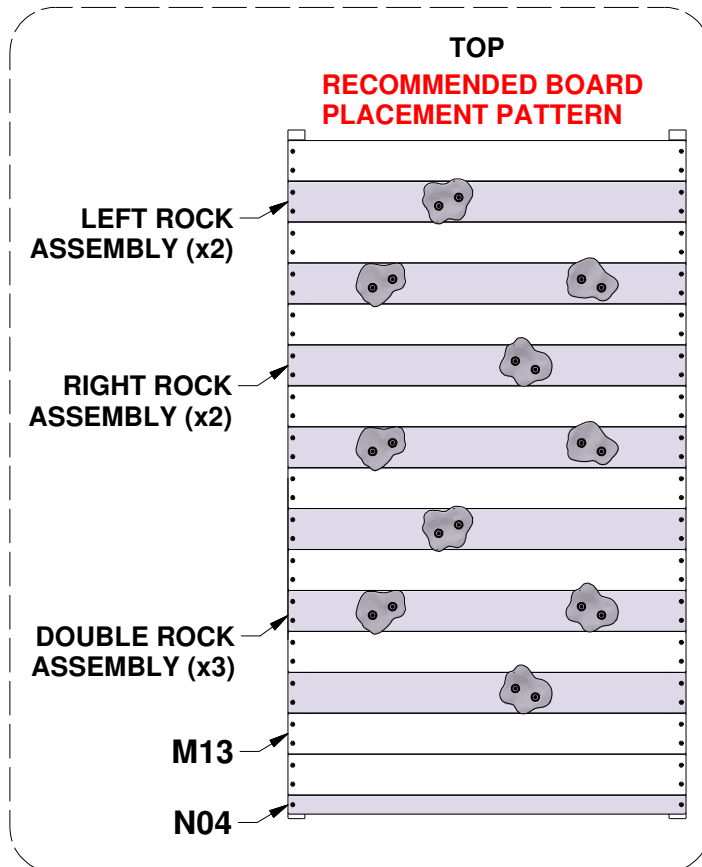
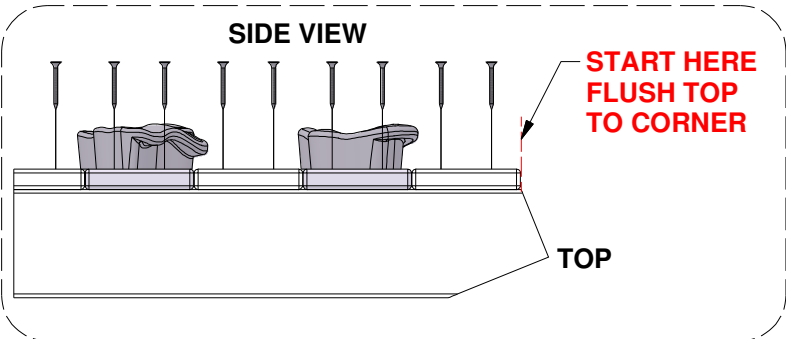

# STEP 3 - ROCK WALL

QTY	PART NUMBER	DESCRIPTION
11	H100380	SCREW PFH 8x1 1/8 BLK



**N05 ROCKWALL CLEAT - W4L21331**  
 (x1) 5/8"x2 3/8"x53 7/8" (16x60x1370)

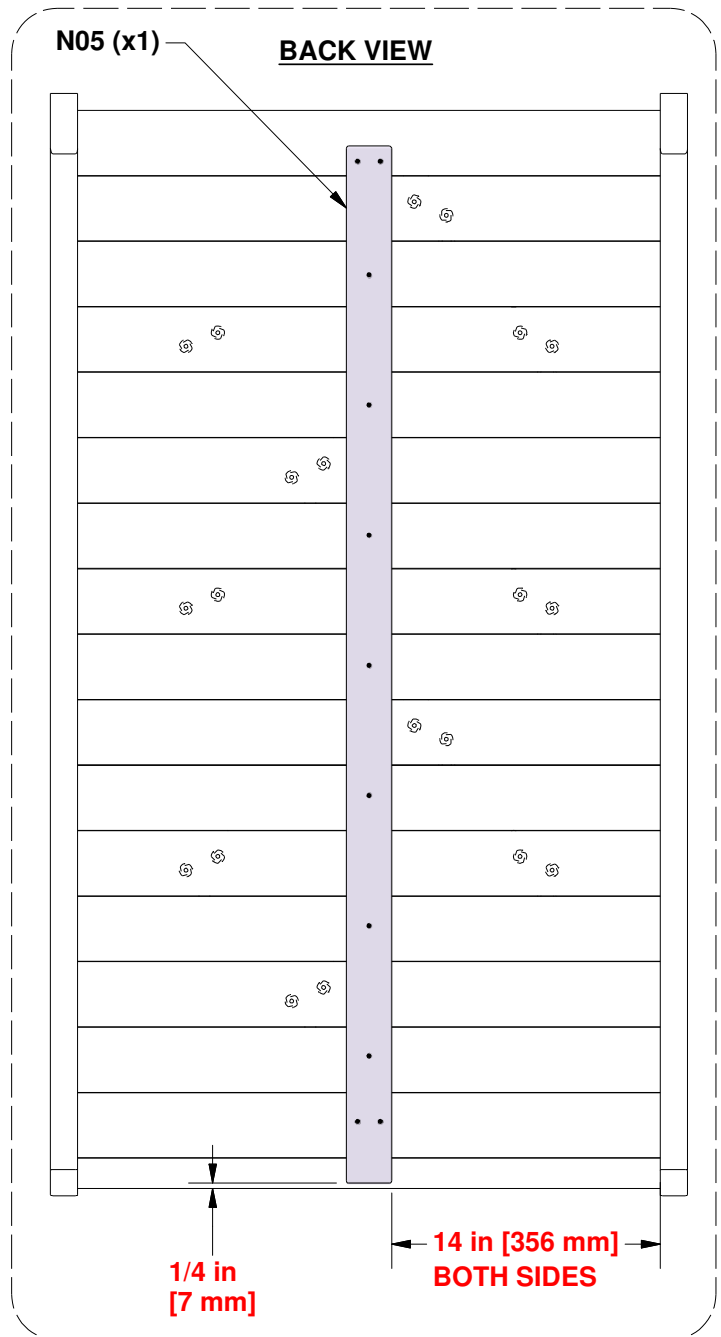
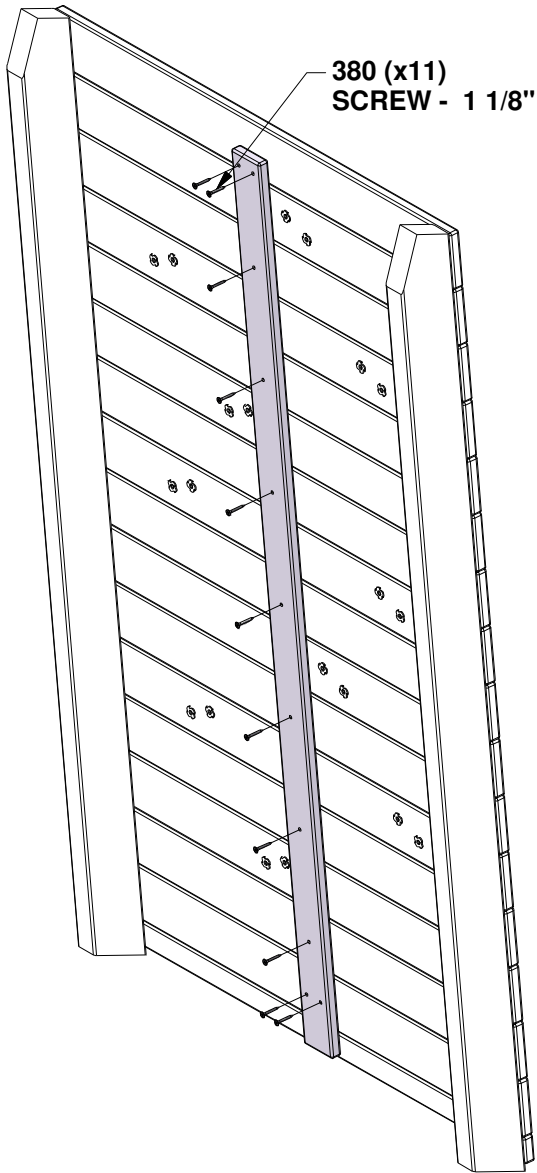

# STEP 4 - ROCK WALL

QTY	PART NUMBER	DESCRIPTION
2	H100379	T-NUT 5/16 BLK
4	H100391	SCREW PFH 8x2 BLK



H11 ATTACHMENT BOARD - W4L21423  
(x1) 1"x3 3/8"x33 1/4" (24x86x843)

## INSTALL T-NUTS IN WOOD FIRST

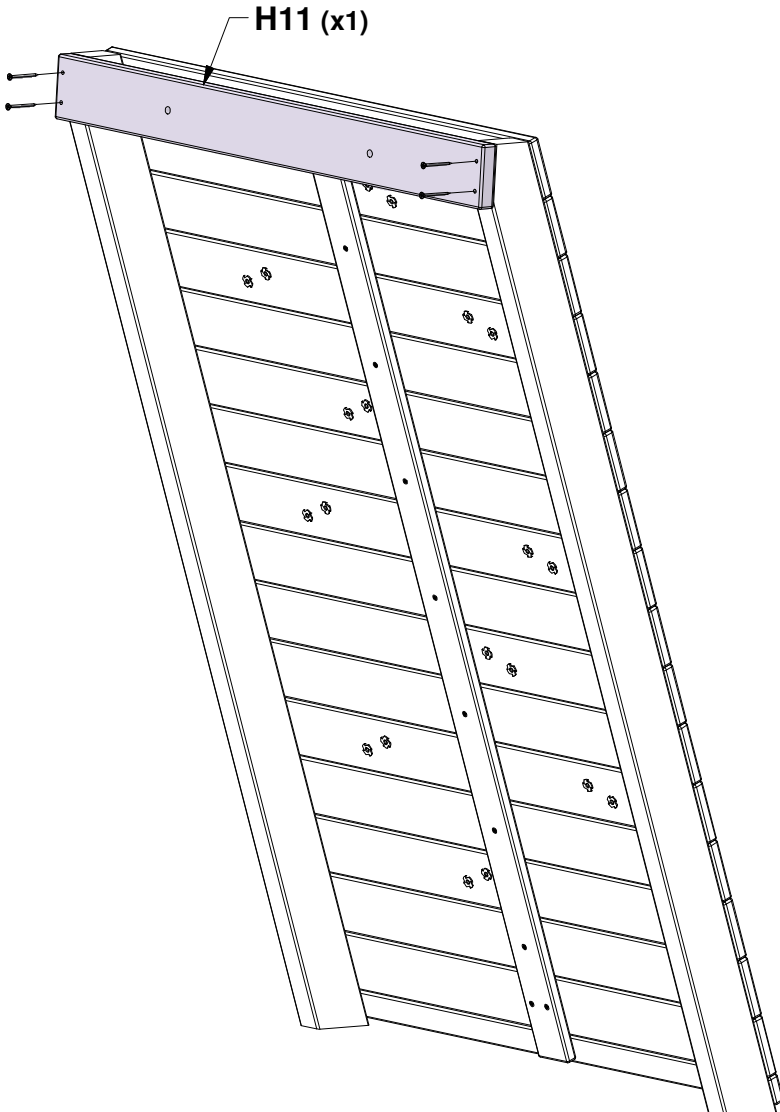
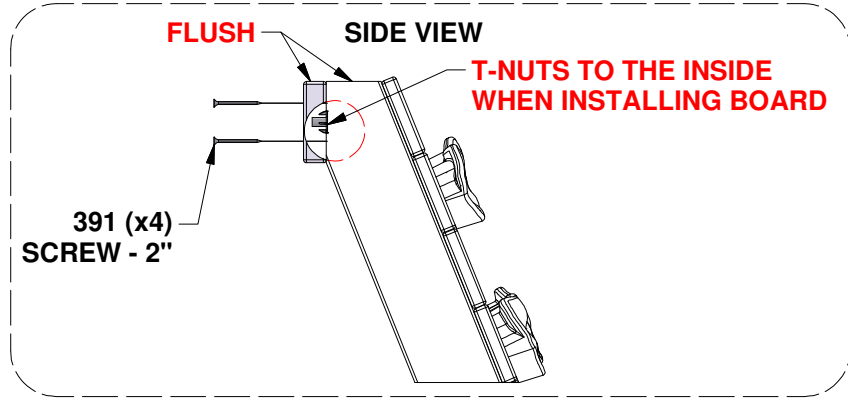
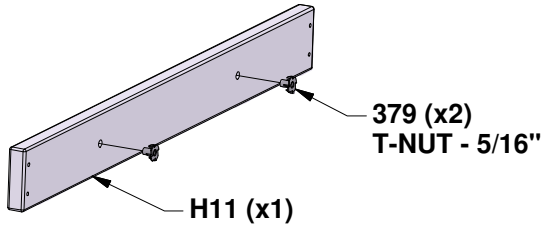

# STEP 5 - ROCK WALL

QTY	PART NUMBER	DESCRIPTION
4	H100391	SCREW PFH 8x2 BLK



**M17 TOP BOARD - W4L21333**  
(x1) 5/8"x3 3/8"x33 1/4" (16x86x843)

**ALIGN BOARD AS SHOWN  
THEN DRILL (4) 1/8" [3mm]  
PILOT HOLES FOR SCREWS.**

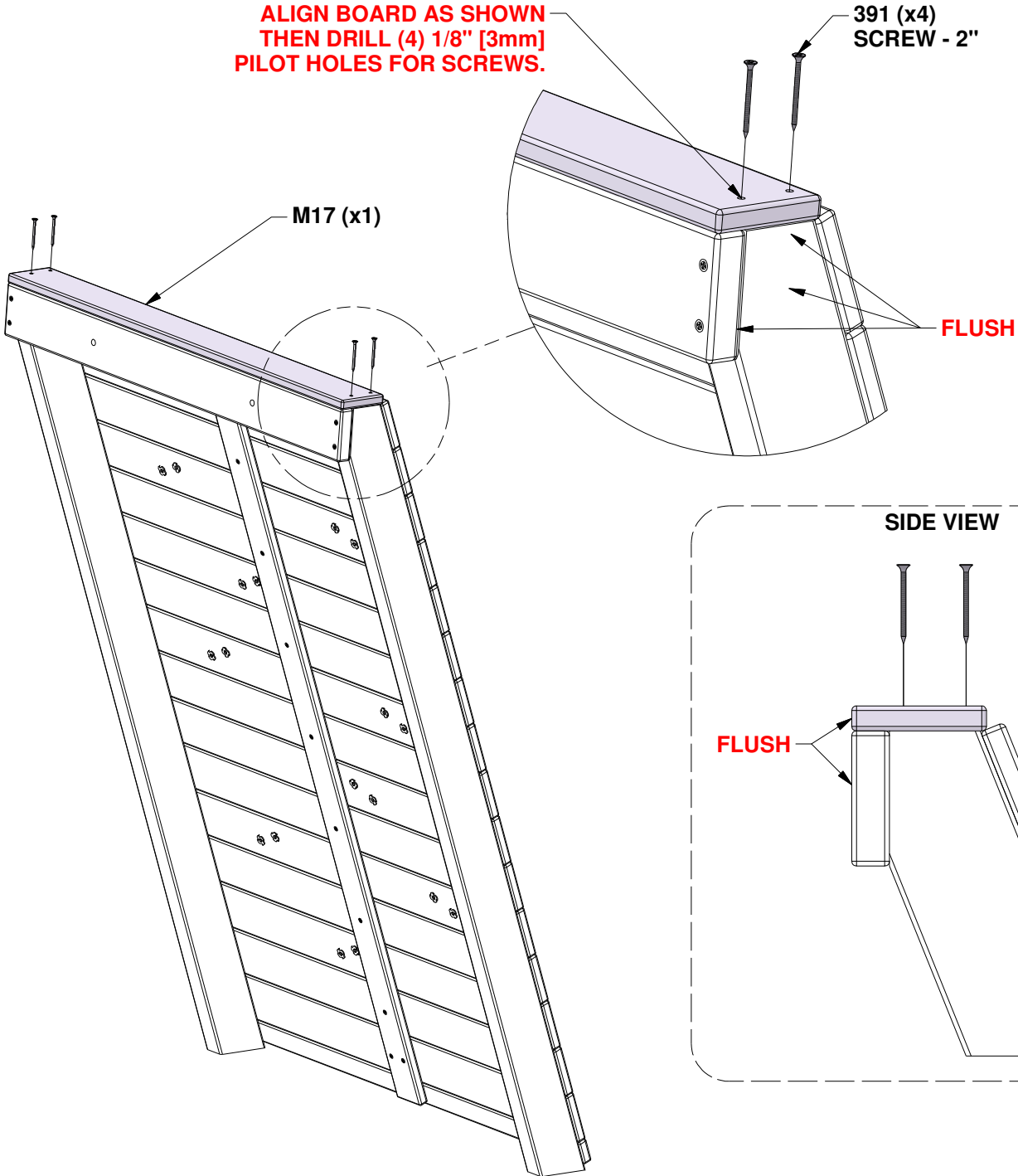

# STEP 1 - SWING BEAM ASSEMBLY

QTY	PART NUMBER	DESCRIPTION
10	H100416	BOLT WH 5/16x3" BLK
10	H100192	NUT BARREL WH 5/16x7/8" BLK

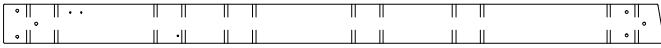

**A1 SWING BEAM EXTENDED - W4L21338**  
(x1) 3 3/8"x5 1/4"x89 1/2" (86x134x2274)



**A2 SB 9" BLOCK - W4L21339**  
(x1) 3 3/8"x5 1/4"x9" (86x134x228)

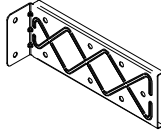

**A4M01679 EXTENDED SWING BEAM BRACKET**  
(x2)

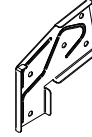

**A4M00617 SWING BEAM EXTENSION BRACKET - LEFT**  
(x1)

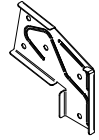

**A4M00618 SWING BEAM EXTENSION BRACKET - RIGHT**  
(x1)

**LEAVE 416 BOLTS & 192 NUT BARRELS HAND TIGHT.**

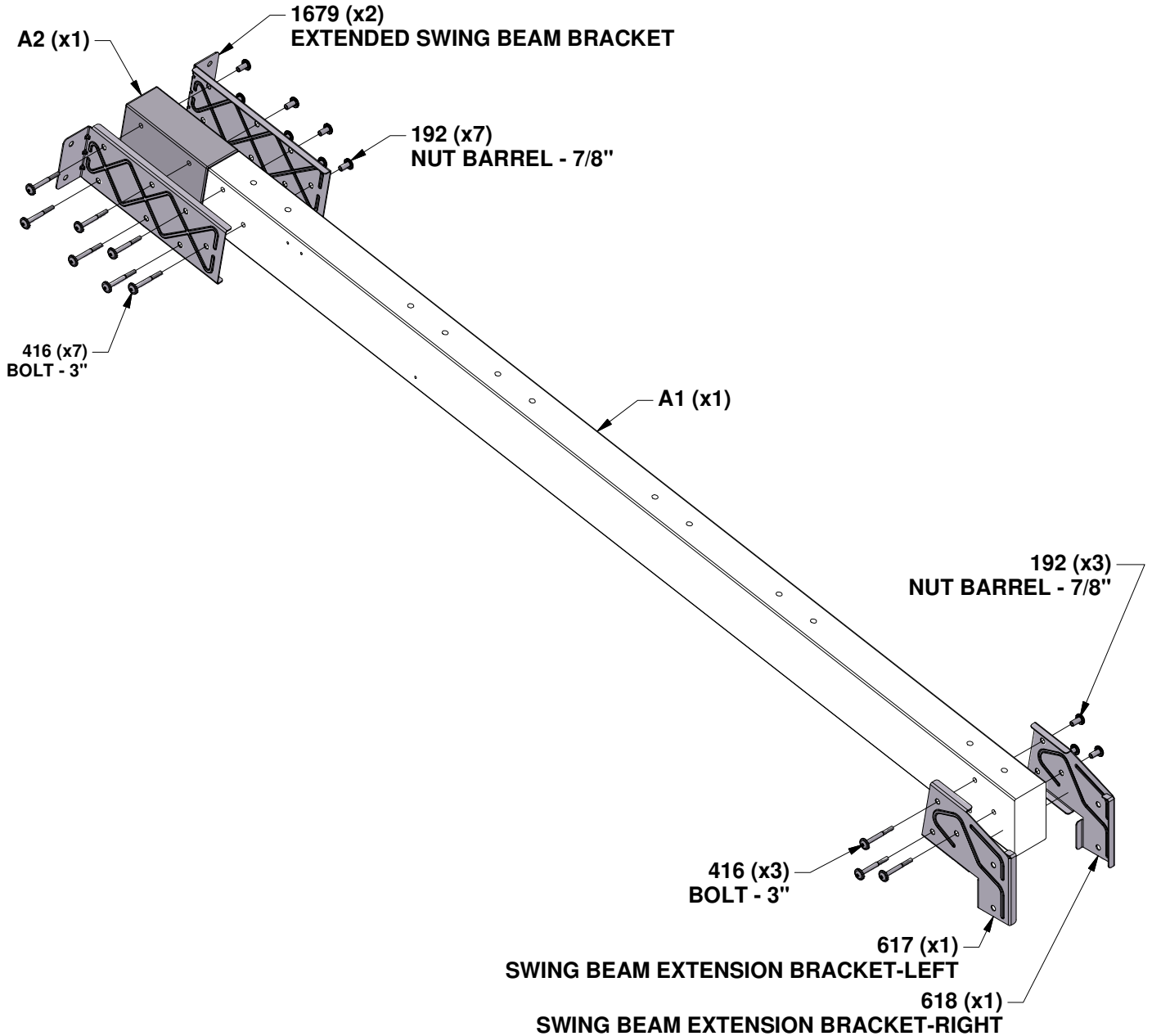
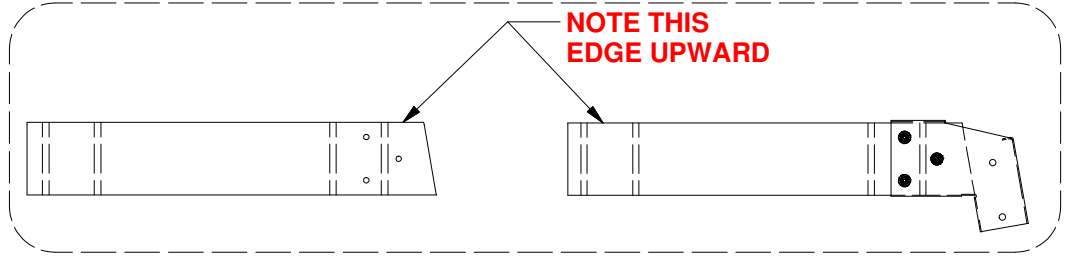

# STEP 2 - SWING BEAM ASSEMBLY

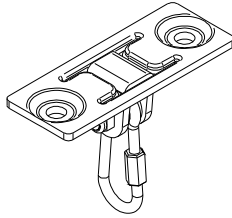

**A4M02171**  
(x6) **SWING HANGER**

QTY	PART NUMBER	DESCRIPTION
12	H101166	WASHER LOCK INT 10x18 BLK
12	H101167	WASHER FLAT 11x25 BLK
12	H101168	T-NUT 3/8" BLK
12	H101169	BOLT HEX 3/8x5-1/2 BLK

**INSTALL T-NUTS IN WOOD FIRST**

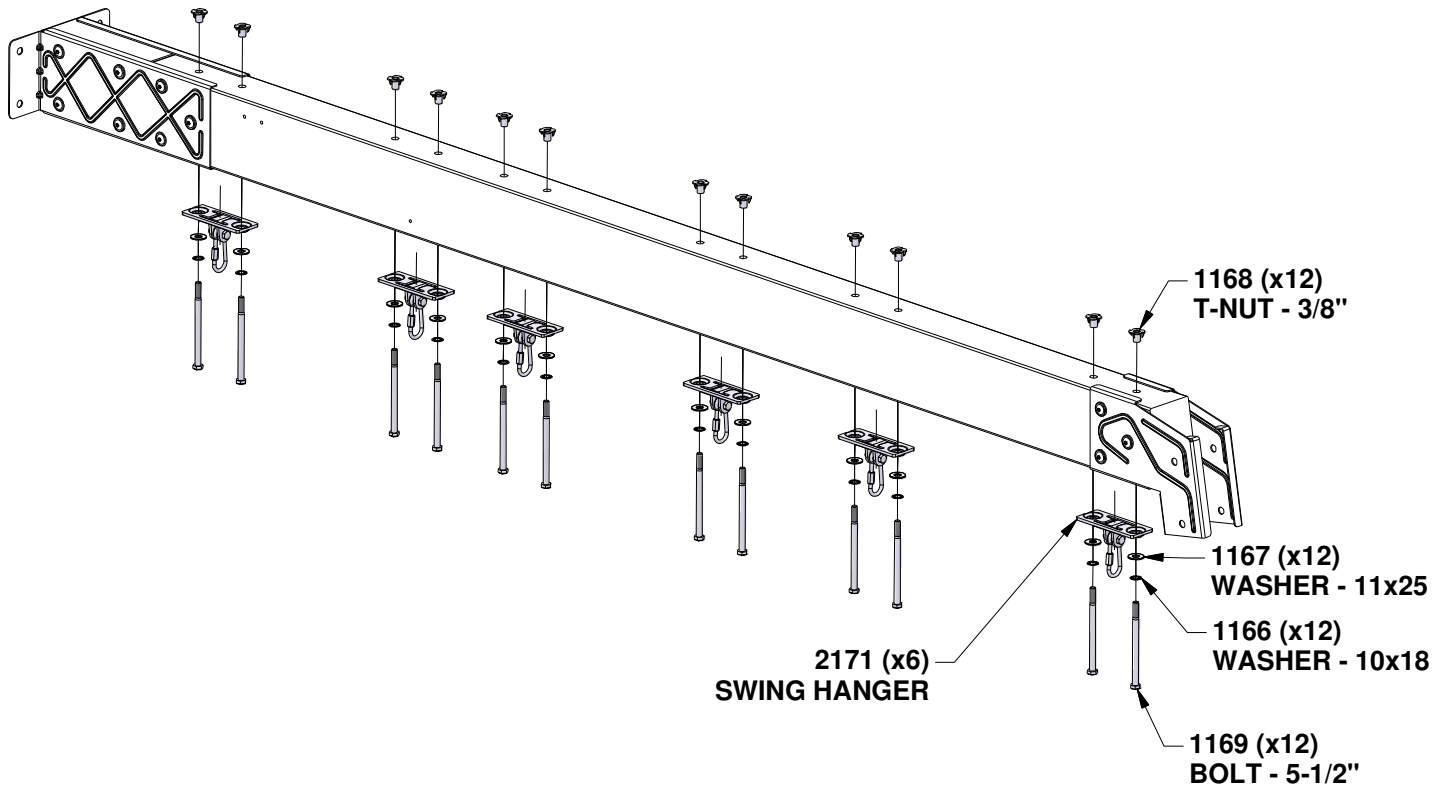

# STEP 3 - SWING BEAM ASSEMBLY

QTY	PART NUMBER	DESCRIPTION
4	H100202	SREW PWH 8x5/8" BLK



**A4M03403 BYD ID TAG LARGE**  
(x1)

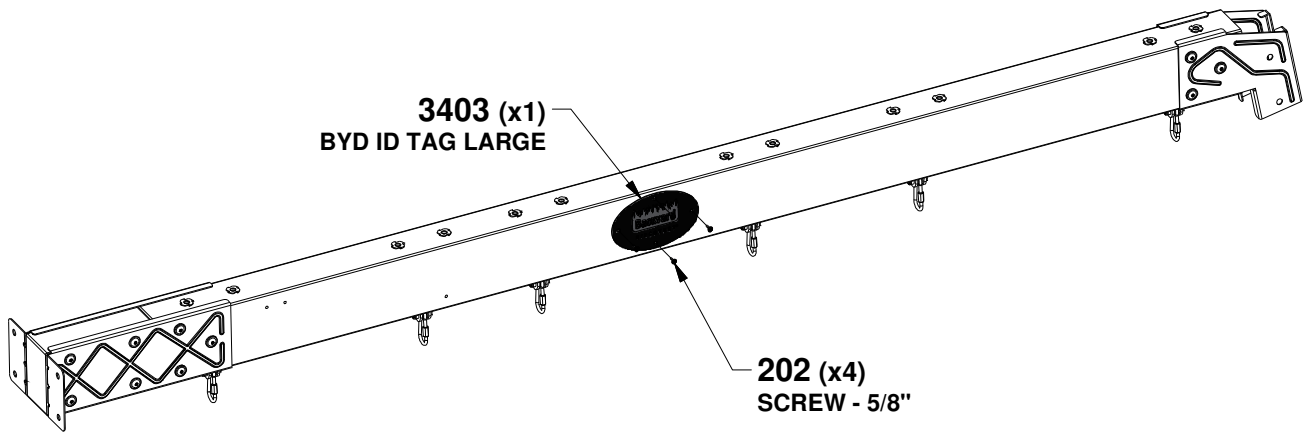
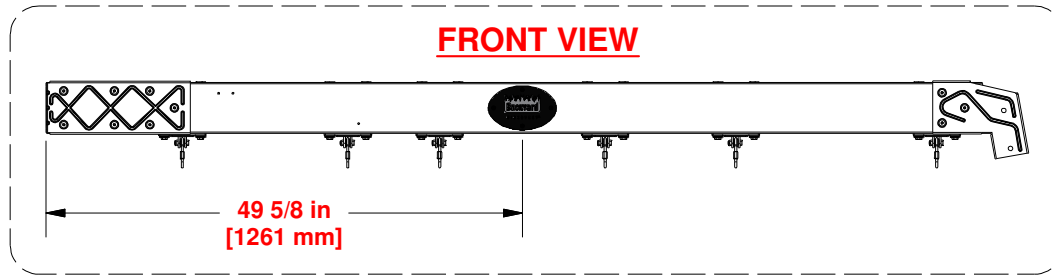

# STEP 4 - SWING BEAM ASSEMBLY

QTY	PART NUMBER	DESCRIPTION
2	H100503	BOLT WH 5/16x3-1/2" BLK
4	H100407	BOLT WH 5/16x1-1/2" BLK
6	H100379	T-NUT 5/16" BLK

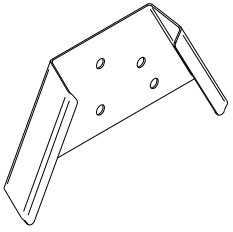

**A4M01782**  
(x1) **A-FRAME BRACKET**



**SP71 SWING BEAM SUPPORT - W4L21337**  
(x1) 3 3/8"x3 3/8"x49 1/2" (86x86x1256)

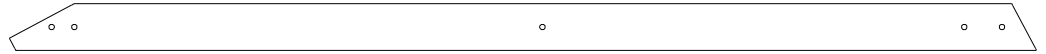

**E80 ANGLE BRACE - W4L21335**  
(x2) 1 3/8"x3 3/8"x74 7/8" (36x86x1903)

## INSTALL T-NUTS IN WOOD FIRST

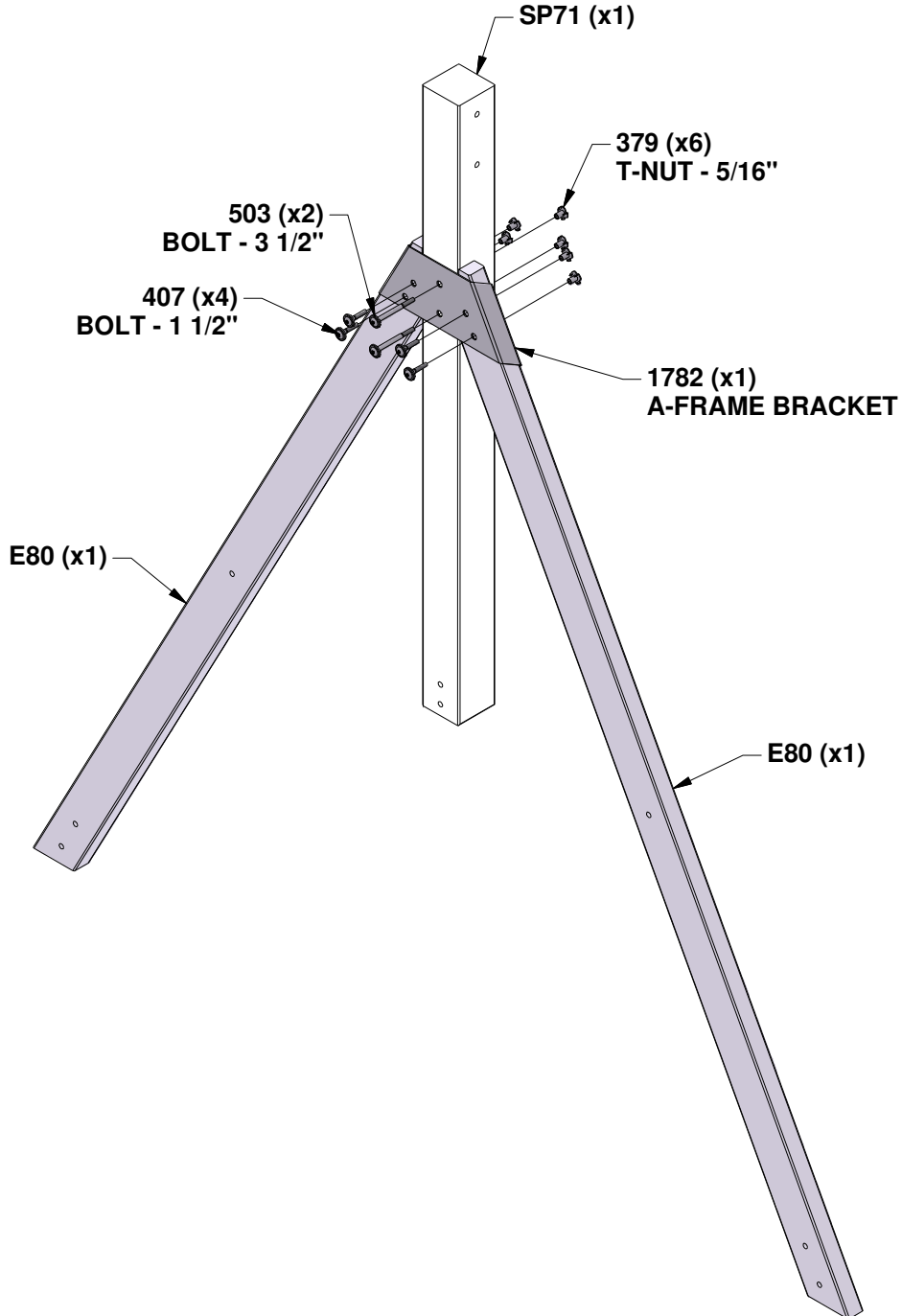

# STEP 5 - SWING BEAM ASSEMBLY

QTY	PART NUMBER	DESCRIPTION
2	H100195	BOLT WH 5/16x2-3/4" BLK
4	H100205	BOLT WH 5/16x2-1/4" BLK
8	H100198	WASHER LOCK EXT 8x19 BLK
8	H100379	T-NUT 5/16" BLK
2	H100480	BOLT WH 5/16x4-3/4" BLK

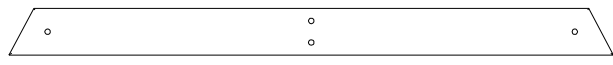

**E79 END SUPPORT - W4L21336**  
(x1) 1 1/2"x3 1/2"x44" (36x86x1120)



**G50 GROUND BOARD - W4L21334**  
(x1) 1"x5 1/4"x75 1/4" (24x134x1912)

**INSTALL T-NUTS IN WOOD FIRST**

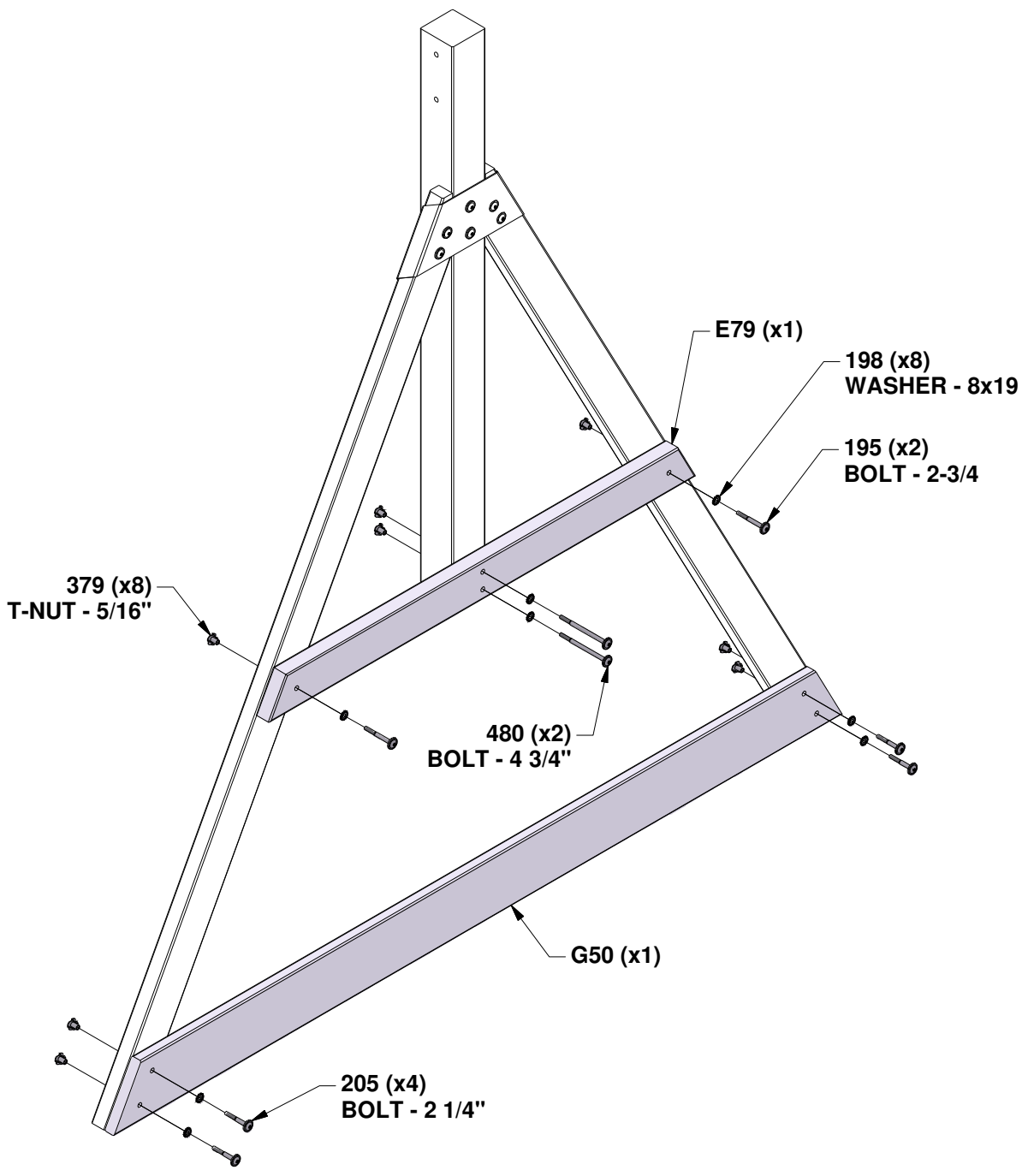

# **STEP 6 - SWING BEAM ASSEMBLY**

QTY	PART NUMBER	DESCRIPTION
2	H100416	BOLT WH 5/16x3" BLK
2	H100192	NUT BARREL WH 5/16x7/8" BLK

**TIGHTEN ALL 416 BOLTS & 192 NUT BARRELS NOW.**

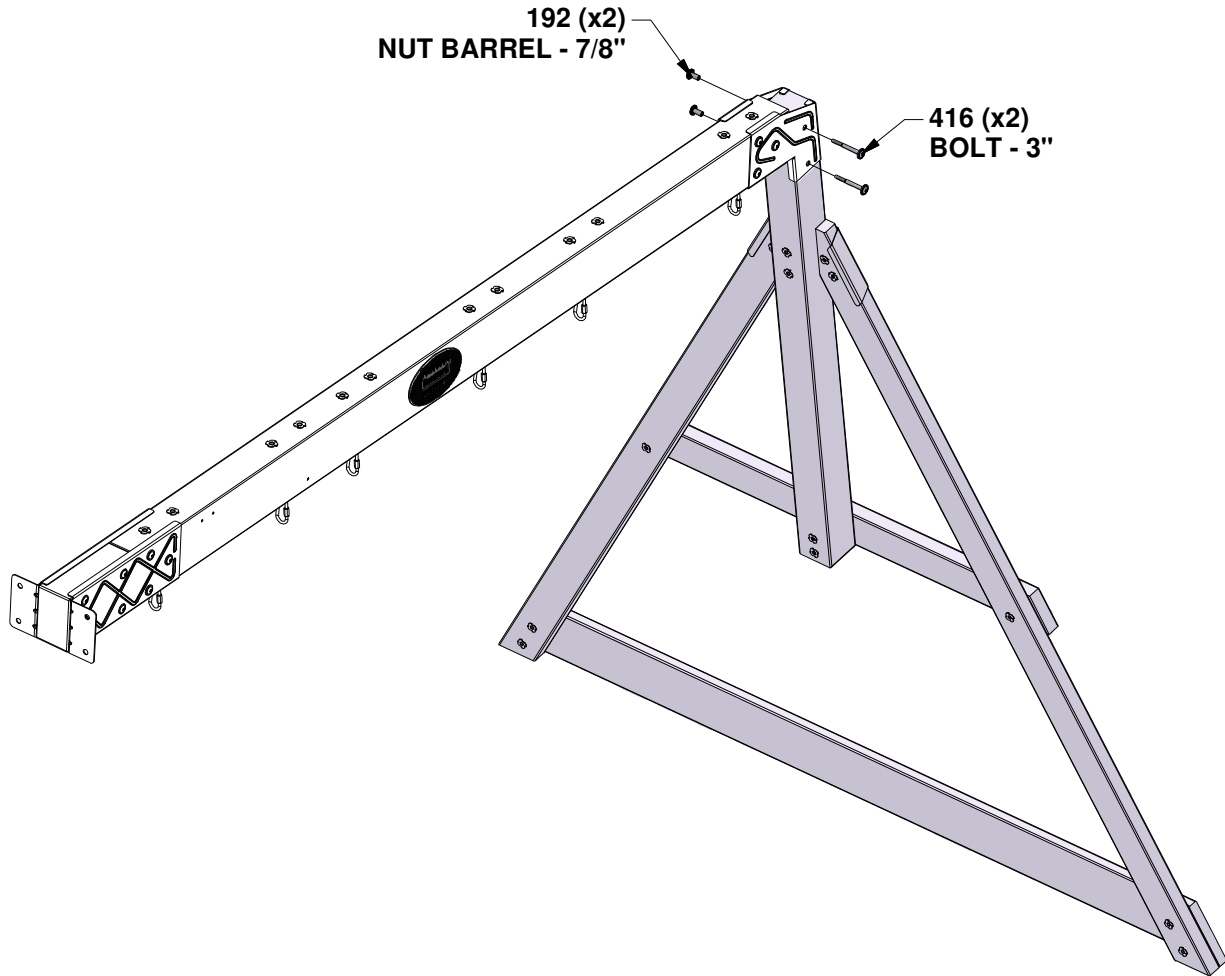

# STEP 1 - FORT ASSEMBLY

QTY	PART NUMBER	DESCRIPTION
8	H100198	WASHER LOCK EXT 8x19 BLK
8	H100379	T-NUT 5/16 BLK
8	H100415	BOLT WH 5/16x3 3/4 BLK

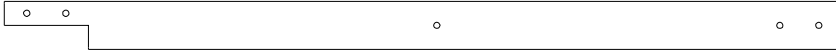

**B03 POST - W4L21357**  
(x1) 3"x3"x52 3/8" (76x76x1330)



**B01 POST ASSEMBLY - W2A03946**  
(x1) 3"x3"x63 7/16" (76x76x1330)



**G06 FLOOR RAIL - W4L21375**  
(x1) 1"x5 1/4"x40" (24x134x1017)

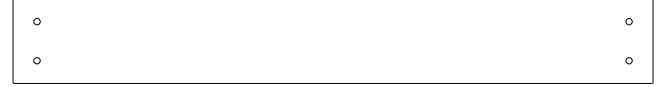

**G02 GROUND BOARD - W4L21360**  
(x1) 1"x5 1/4"x40" (24x134x1017)

## INSTALL T-NUTS IN WOOD FIRST

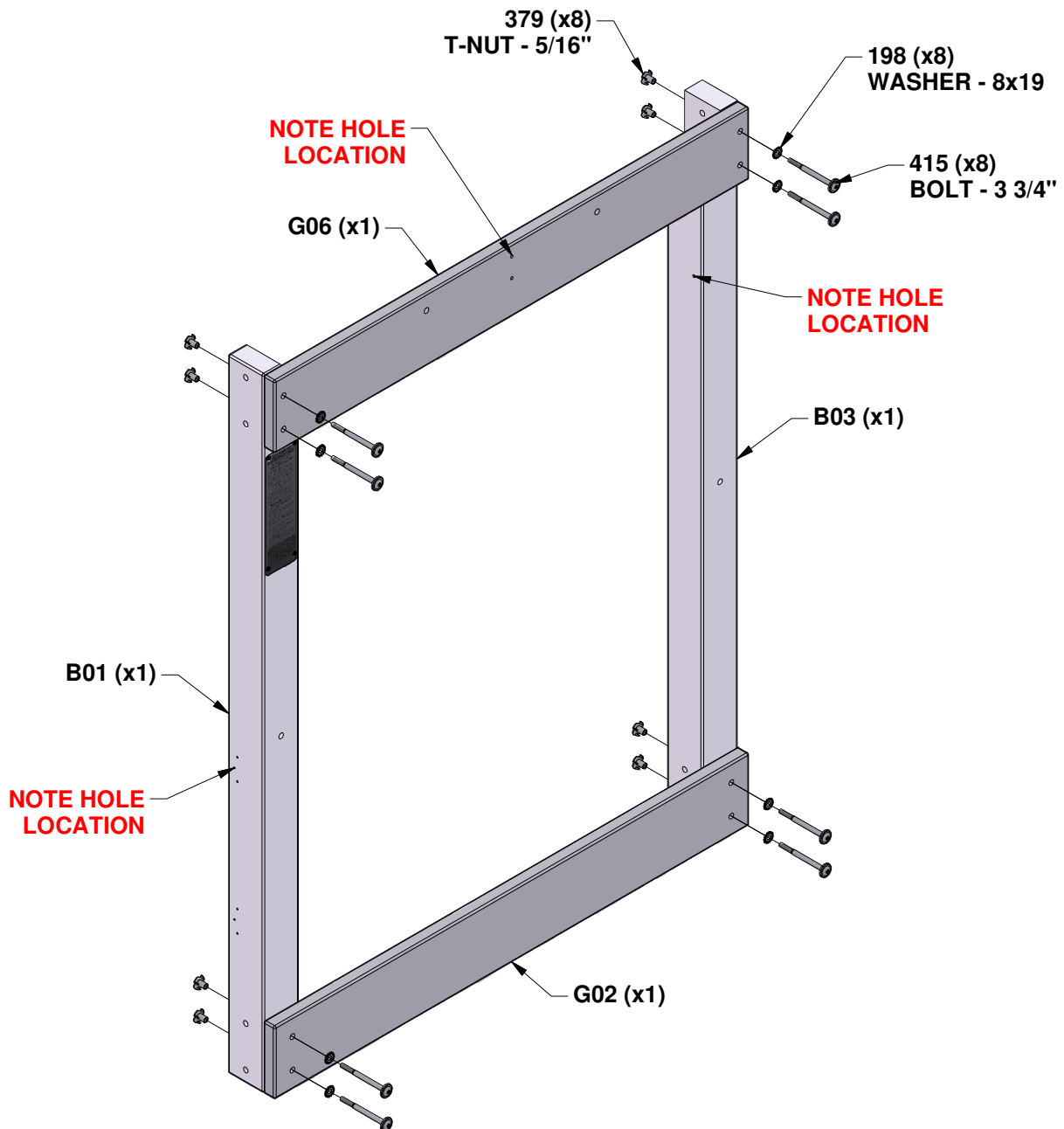

# STEP 2 - FORT ASSEMBLY

QTY	PART NUMBER	DESCRIPTION
8	H100198	WASHER LOCK EXT 8x19 BLK
8	H100379	T-NUT 5/16 BLK
8	H100415	BOLT WH 5/16x3 3/4 BLK

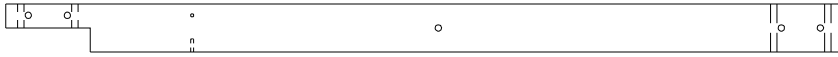

**B02 POST - W4L21356**  
(x1) 3"x3"x52 3/8" (76x76x1330)



**B04 POST - W4L21358**  
(x1) 3"x3"x52 3/8" (76x76x1330)



**G02 GROUND BOARD - W4L21360**  
(x1) 1"x5 1/4"x40" (24x134x1017)

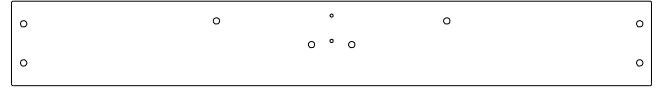

**G07 FLOOR RAIL - W4L21376**  
(x1) 1"x5 1/4"x40" (24x134x1017)

## INSTALL T-NUTS IN WOOD FIRST

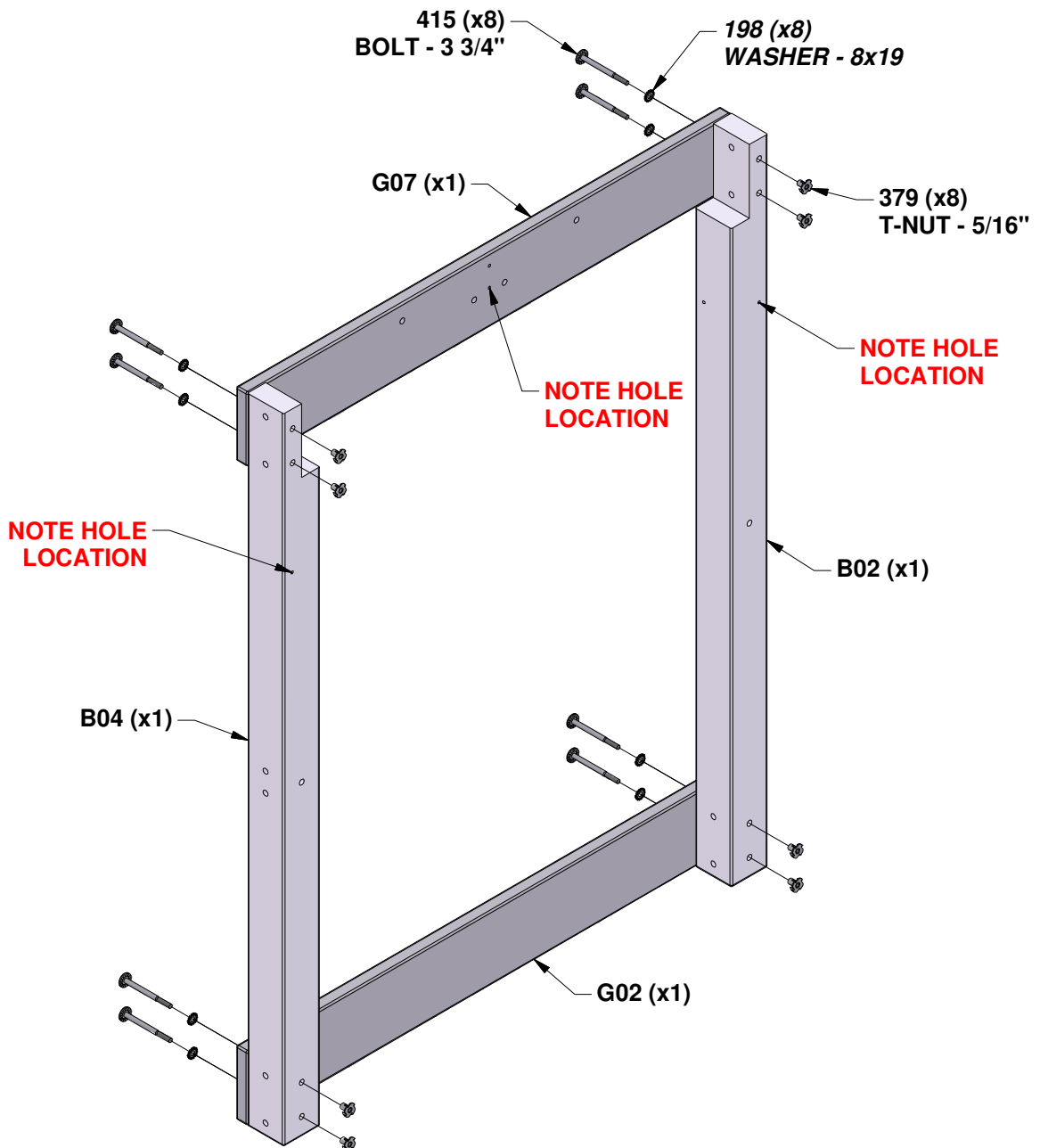

# STEP 3 - FORT ASSEMBLY

QTY	PART NUMBER	DESCRIPTION
8	H100198	WASHER LOCK EXT 8x19 BLK
8	H100379	T-NUT 5/16 BLK
8	H100415	BOLT WH 5/16x3 3/4 BLK



**G01 GROUND BOARD - W4L21359**  
(x1) 1"x5 1/4"x59" (24x134x1498)



**G03 GROUND BOARD - W4L21418**  
(x1) 1"x5 1/4"x59" (24x134x1498)

## INSTALL T-NUTS IN WOOD FIRST

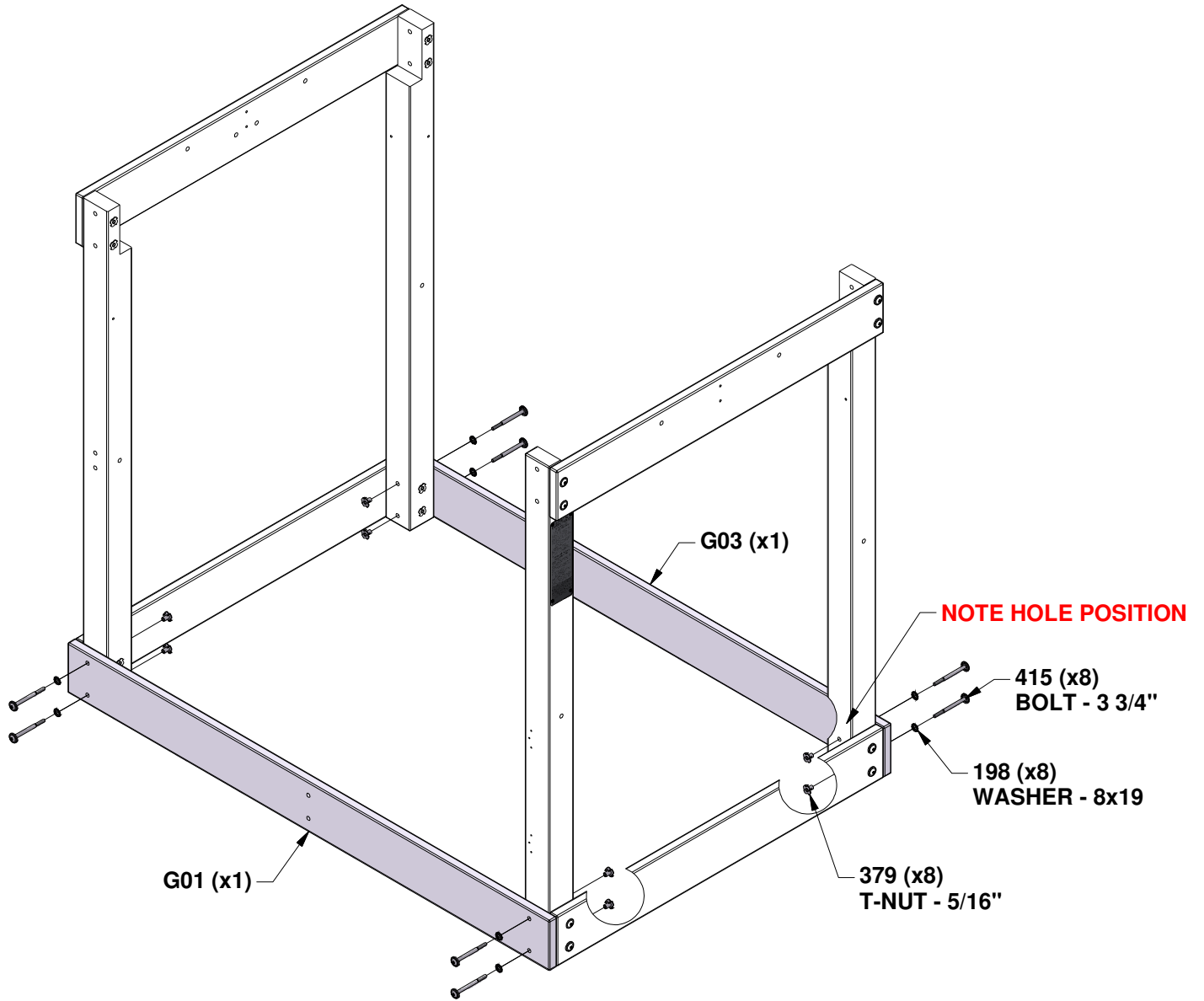

# STEP 4 - FORT ASSEMBLY

QTY	PART NUMBER	DESCRIPTION
2	H100198	WASHER LOCK EXT 8x19 BLK
2	H100379	T-NUT 5/16 BLK
2	H100415	BOLT WH 5/16x3 3/4 BLK



H02 WALL RAIL - W4L21363  
(x1) 1"x3 3/8"x40" (24x86x1017)

## INSTALL T-NUTS IN WOOD FIRST

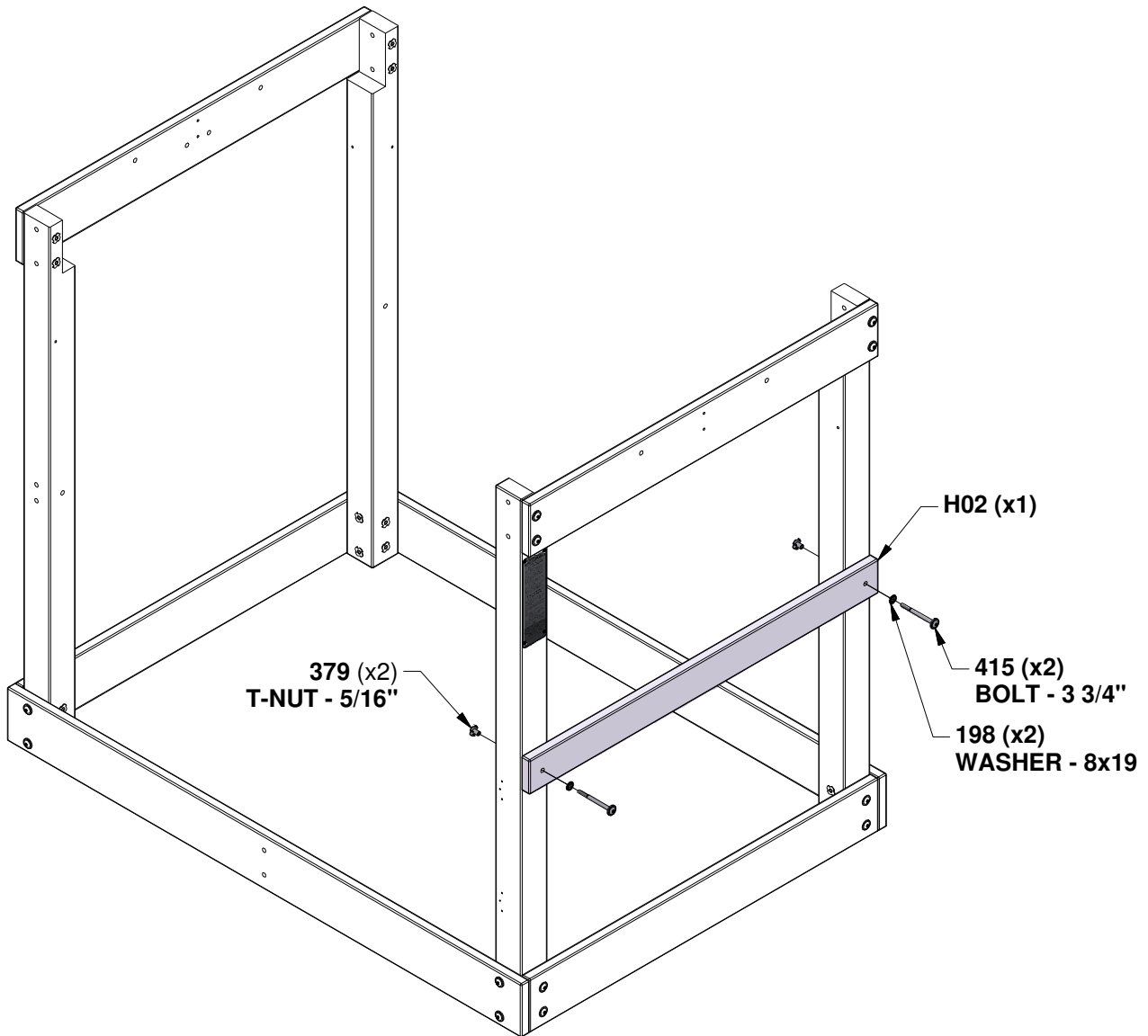

# STEP 5 - FORT ASSEMBLY

QTY	PART NUMBER	DESCRIPTION
7	H100198	WASHER LOCK EXT 8x19 BLK
3	H100205	BOLT WH 5/16x2 1/4 BLK
7	H100379	T-NUT 5/16 BLK
4	H100415	BOLT WH 5/16x3 3/4 BLK



**E05 WALL UPRIGHT - W4L21364**  
(x1) 1 3/8"x3 3/8"x49 1/2" (36x86x1256)



**H01 COUNTERTOP RAIL - W4L21362**  
(x1) 1"x3 3/8"x31 1/8" (24x86x792)



**H04 WALL RAIL - W4L21365**  
(x1) 1"x3 3/8"x40" (24x86x1017)

## INSTALL T-NUTS IN WOOD FIRST

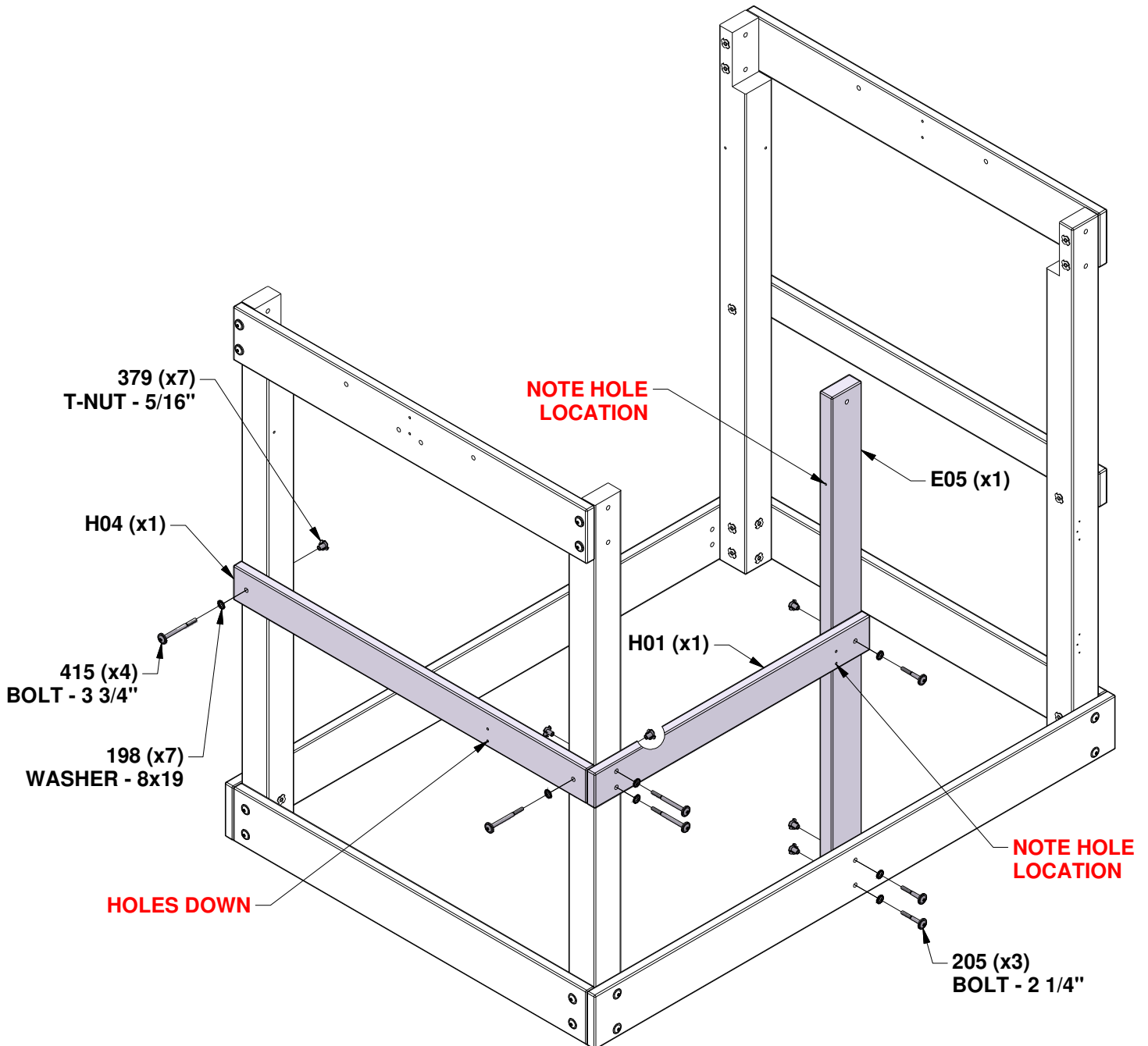

# STEP 6 - FORT ASSEMBLY

QTY	PART NUMBER	DESCRIPTION
40	H100387	SCREW PFH 8x1 1/4 BLK

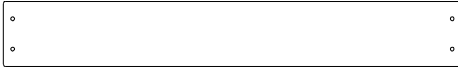

**M01 PICKET - W4L21369**  
 (x10) 5/8"x3 3/8"x23 7/8" (16x86x606)

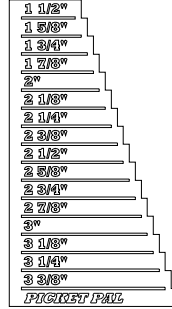
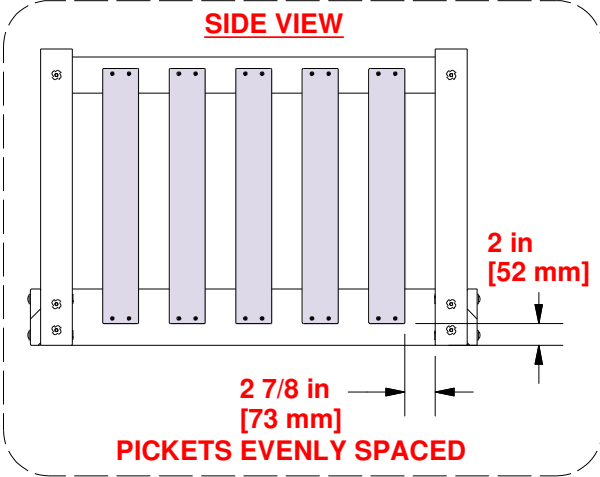

**PICKET PAL**

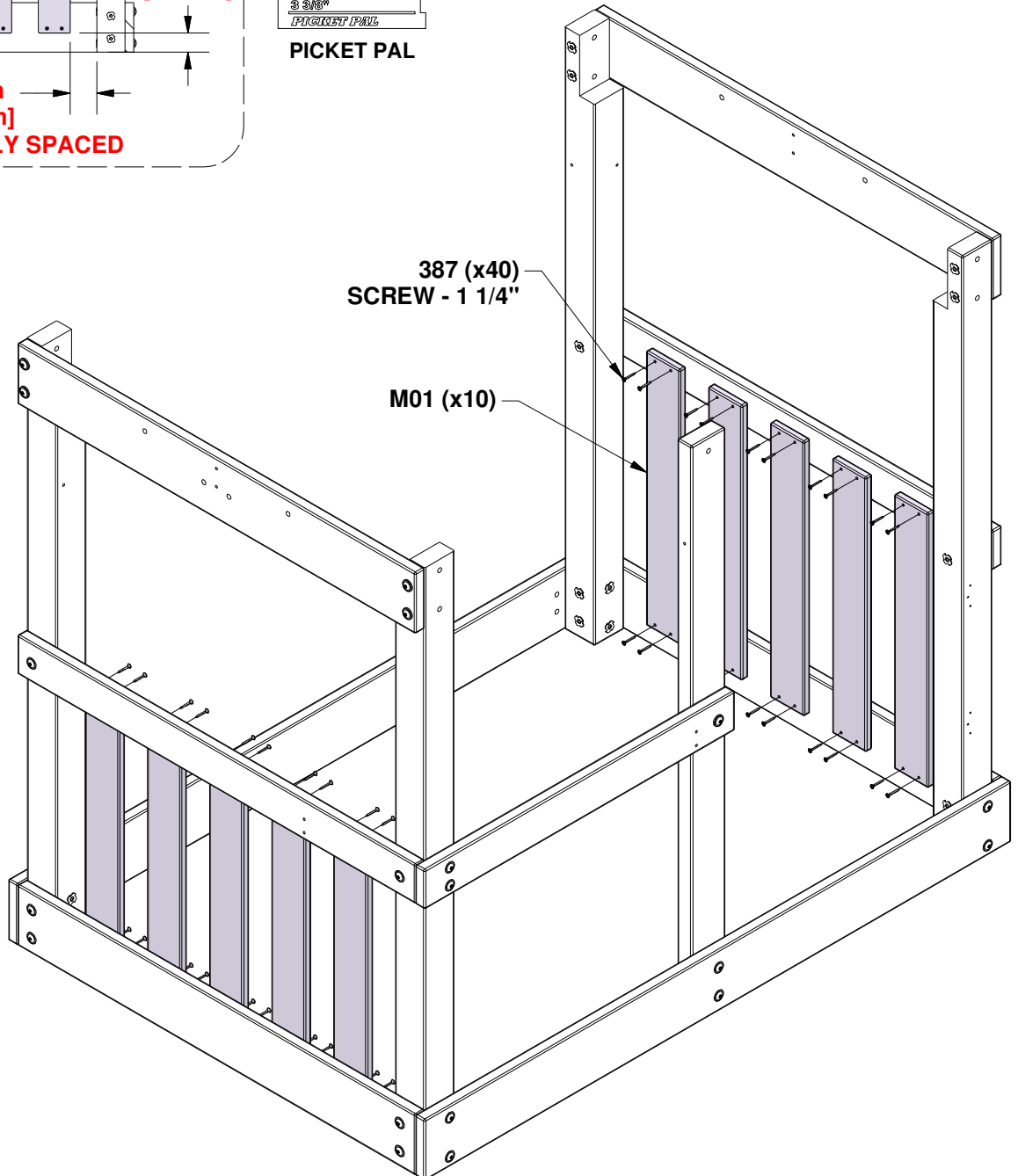

# STEP 7 - FORT ASSEMBLY

QTY	PART NUMBER	DESCRIPTION
16	H100387	SCREW PFH 8x1 1/4 BLK



**M01 PICKET - W4L21369**  
**(x4) 5/8"x3 3/8"x23 7/8" (16x86x606)**

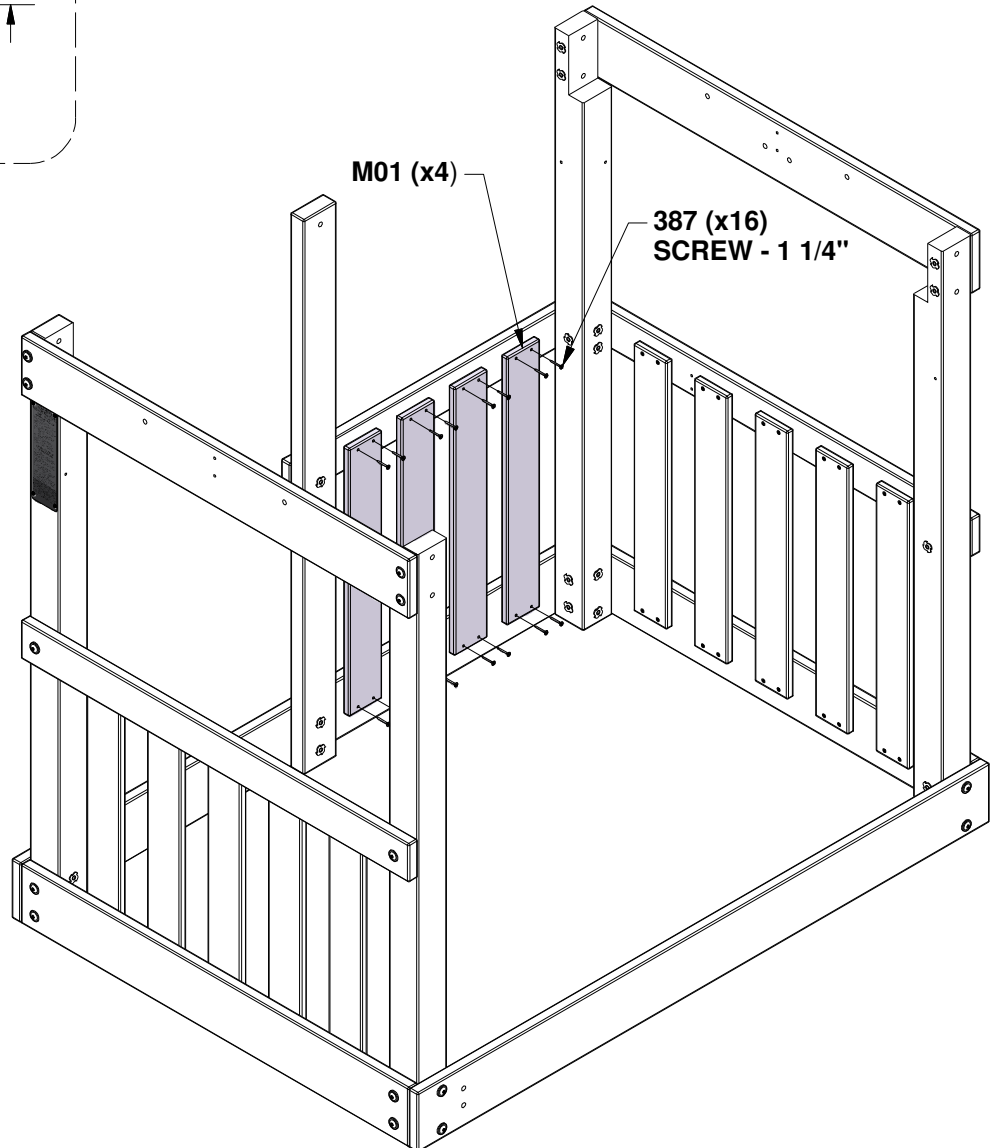
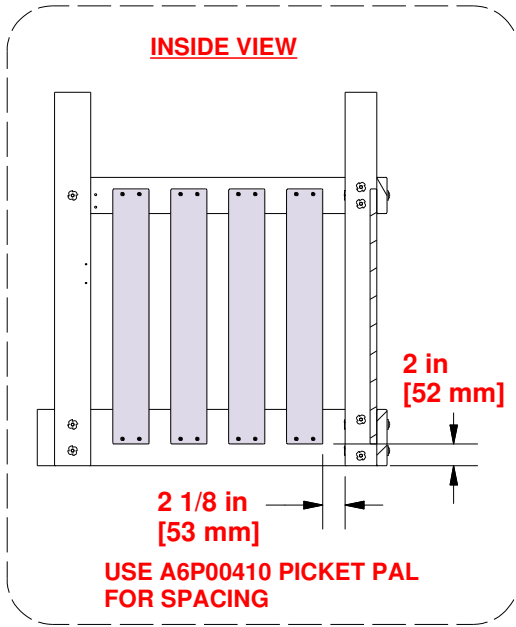

# STEP 8 - FORT ASSEMBLY

QTY	PART NUMBER	DESCRIPTION
10	H100391	SCREW PFH 8x2 BLK
4	H100797	SCREW PWH 8x1 BLK



**J01 COUNTERTOP RAIL - W4L21366**  
 (x1) 1"x2 3/8"x26 7/8" (24x60x682)

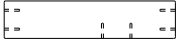

**J02 COUNTERTOP RAIL - W4L21367**  
 (x1) 1"x2 3/8"x10 3/4" (24x60x272)



**J03 COUNTERTOP RAIL - W4L21368**  
 (x1) 1"x2 3/8"x10 3/4" (24x60x272)



**A4M02635 METAL ANGLE BRACE**  
 (x1)

## ALIGN PILOT HOLES

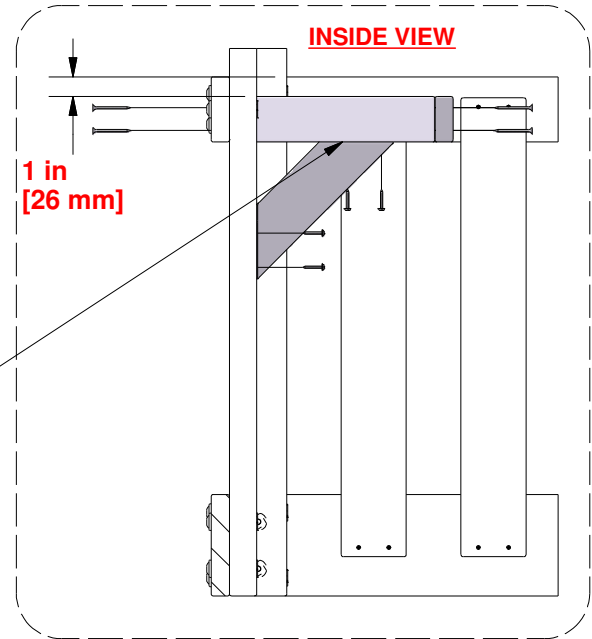

**NOTE PILOT HOLES ON J02 FACE DOWNWARDS**

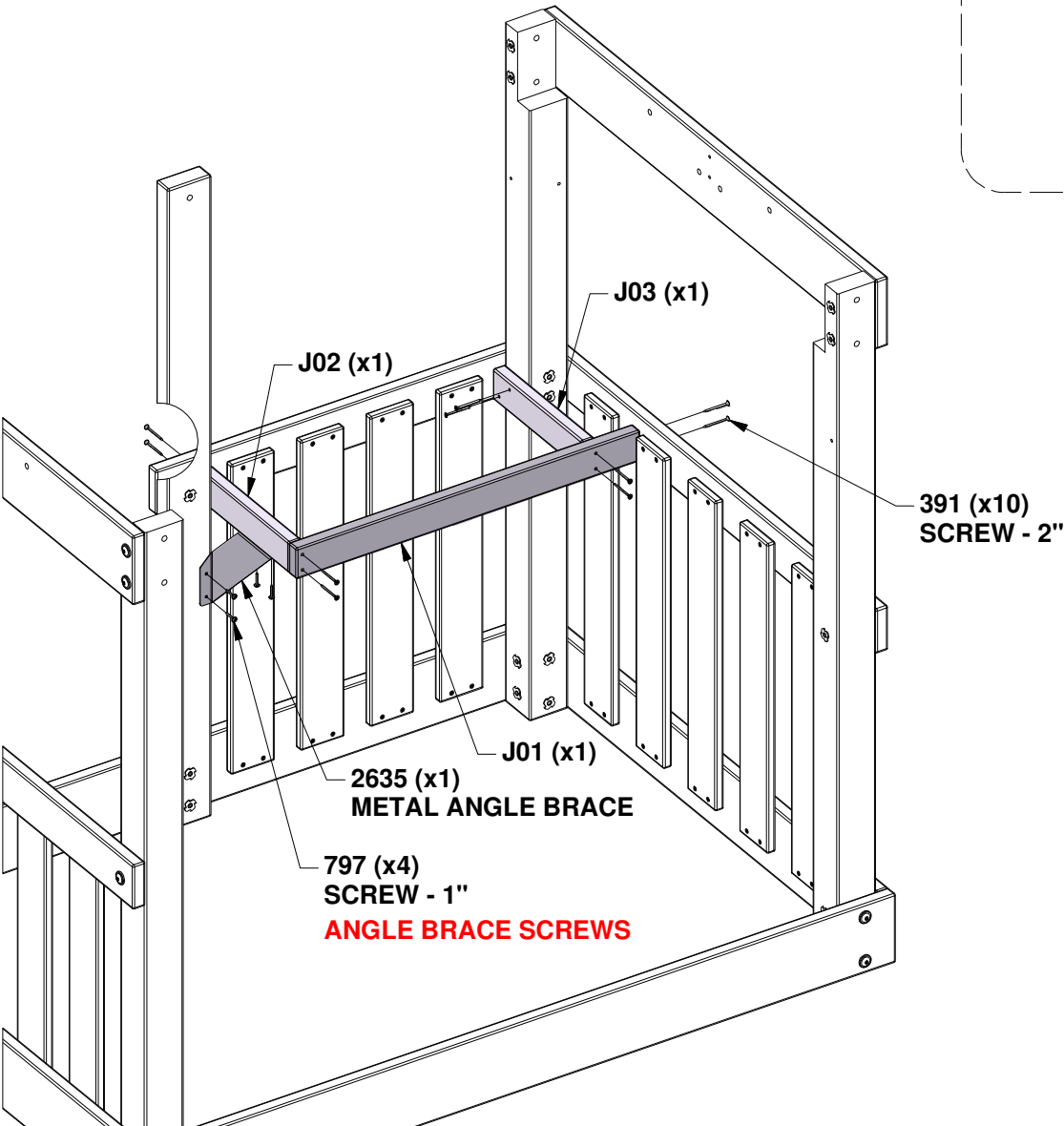

# STEP 9 - FORT ASSEMBLY

QTY	PART NUMBER	DESCRIPTION
11	H100200	SCREW PFH 8x1 1/2 BLK

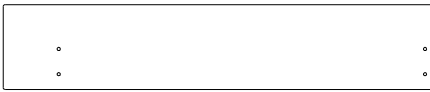

**K01 COUNTERTOP BOARD - W4L21372**  
(x1) 5/8"x5 1/4"x26 7/8" (16x134x682)

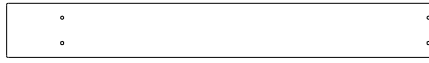

**M02 COUNTERTOP BOARD - W4L21370**  
(x1) 5/8"x3 3/8"x26 7/8" (16x86x682)



**M03 COUNTERTOP BOARD - W4L21371**  
(x1) 5/8"x3"x23 7/8" (16x76x605)

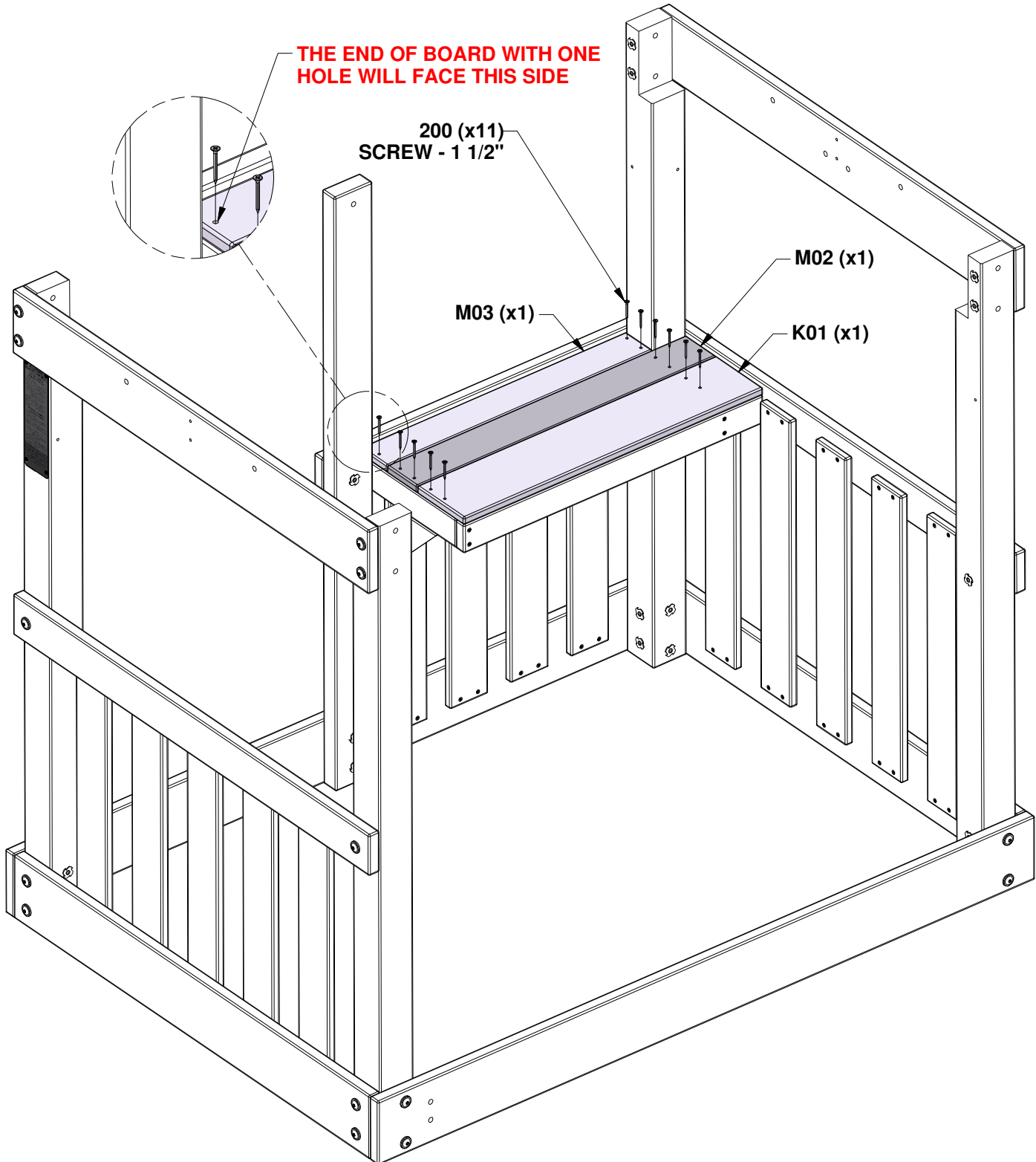

# STEP 10 - FORT ASSEMBLY

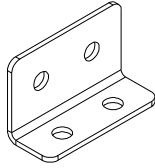

**A4M00855 L BRACKET**  
(x1) 32x51x82

QTY	PART NUMBER	DESCRIPTION
2	H100192	NUT BARREL WH 5/16x7/8 BLK
2	H100199	WASHER LOCK EXT 12x19 BLK
2	H100396	BOLT WH 5/16x1/2 BLK

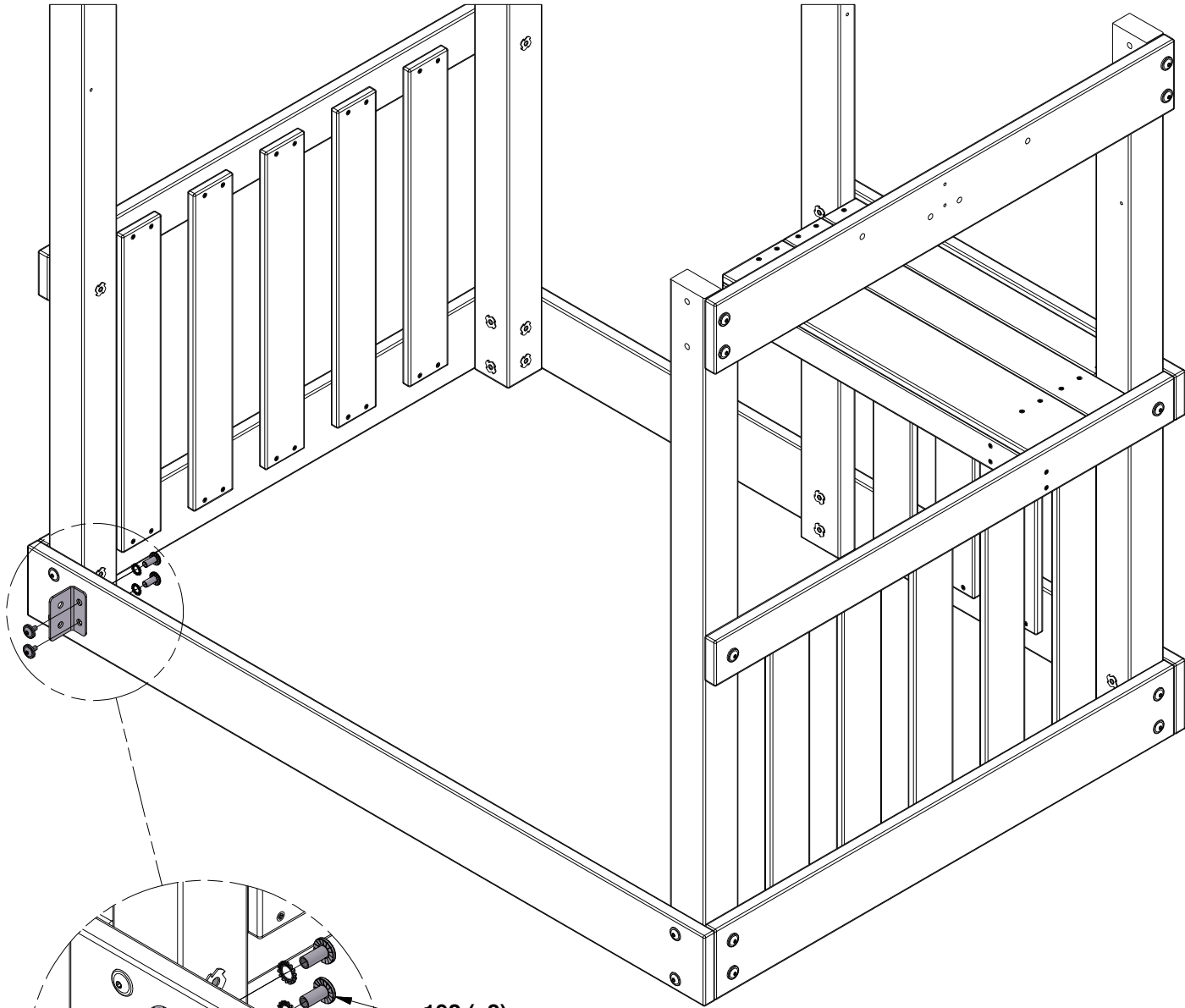

192 (x2)  
NUT BARREL - 7/8"  
199 (x2)  
WASHER - 12x19

855 (x1)  
L BRACKET 32x51x82

396 (x2)  
BOLT - 1/2"

# STEP 11 - FORT ASSEMBLY

QTY	PART NUMBER	DESCRIPTION
9	H100198	WASHER LOCK EXT 8x19 BLK
1	H100205	BOLT WH 5/16x2-1/4 BLK
9	H100379	T-NUT 5/16 BLK
8	H100415	BOLT WH 5/16x3 3/4 BLK

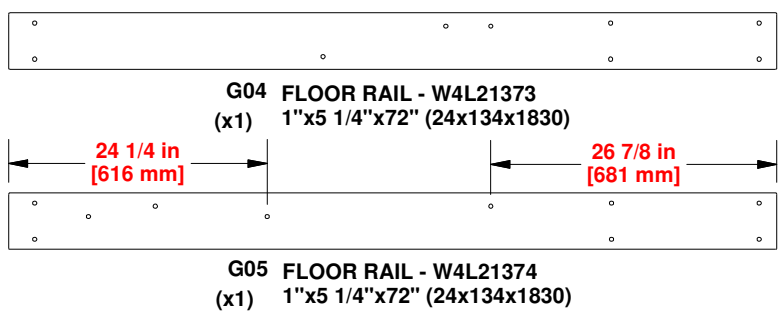
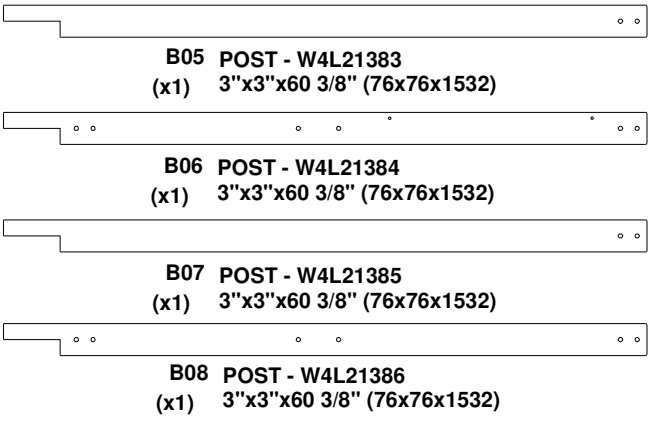

## INSTALL T-NUTS IN WOOD FIRST

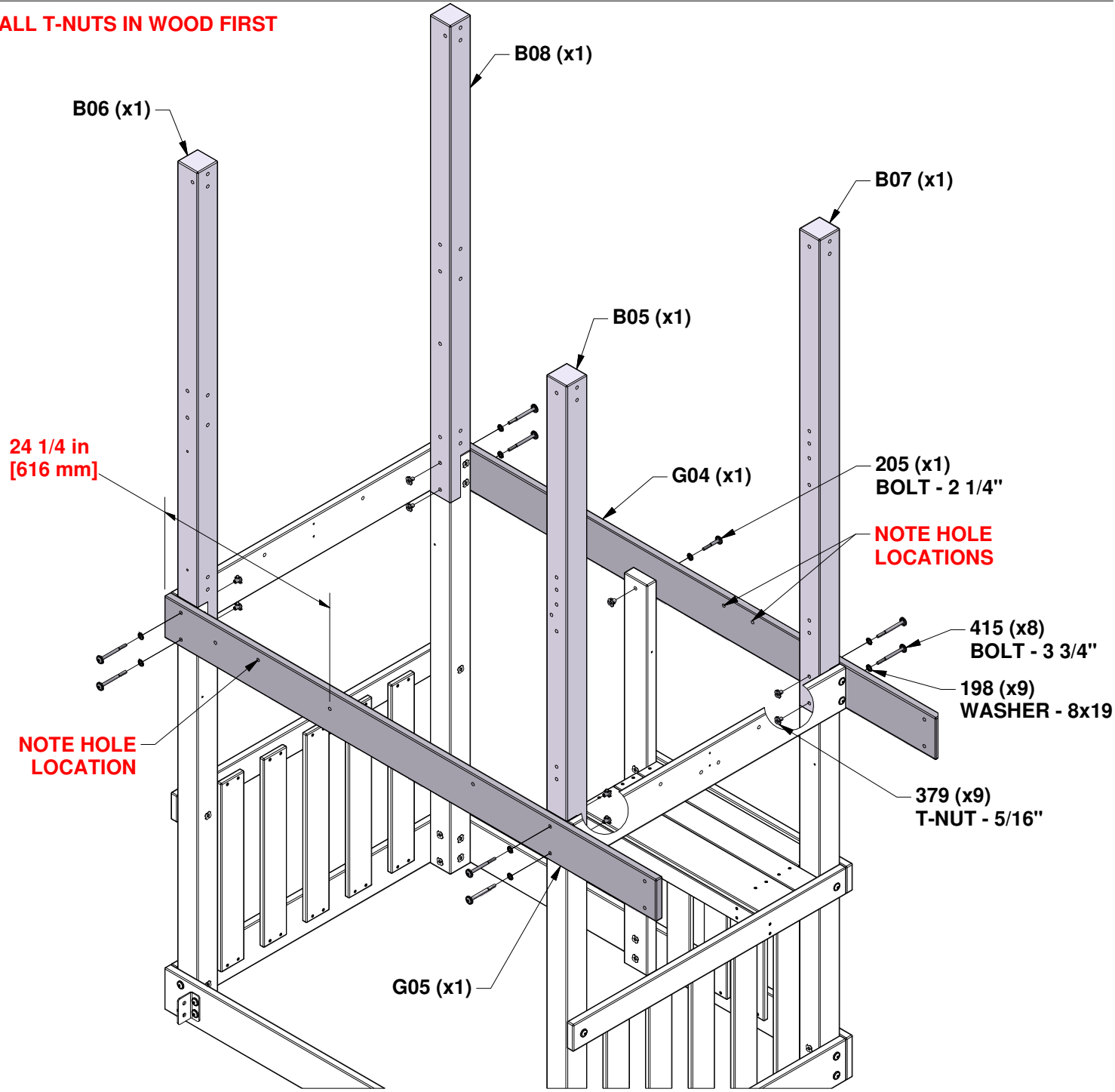

# STEP 12 - FORT ASSEMBLY

QTY	PART NUMBER	DESCRIPTION
4	H100201	SCREW PFH 8x2 1/2 BLK



H05 FLOOR JOIST - W4L21377  
(x1) 1"x3 3/8"x57 1/8" (24x86x1450)

**ALIGN PILOT HOLES ON BOTH ENDS**

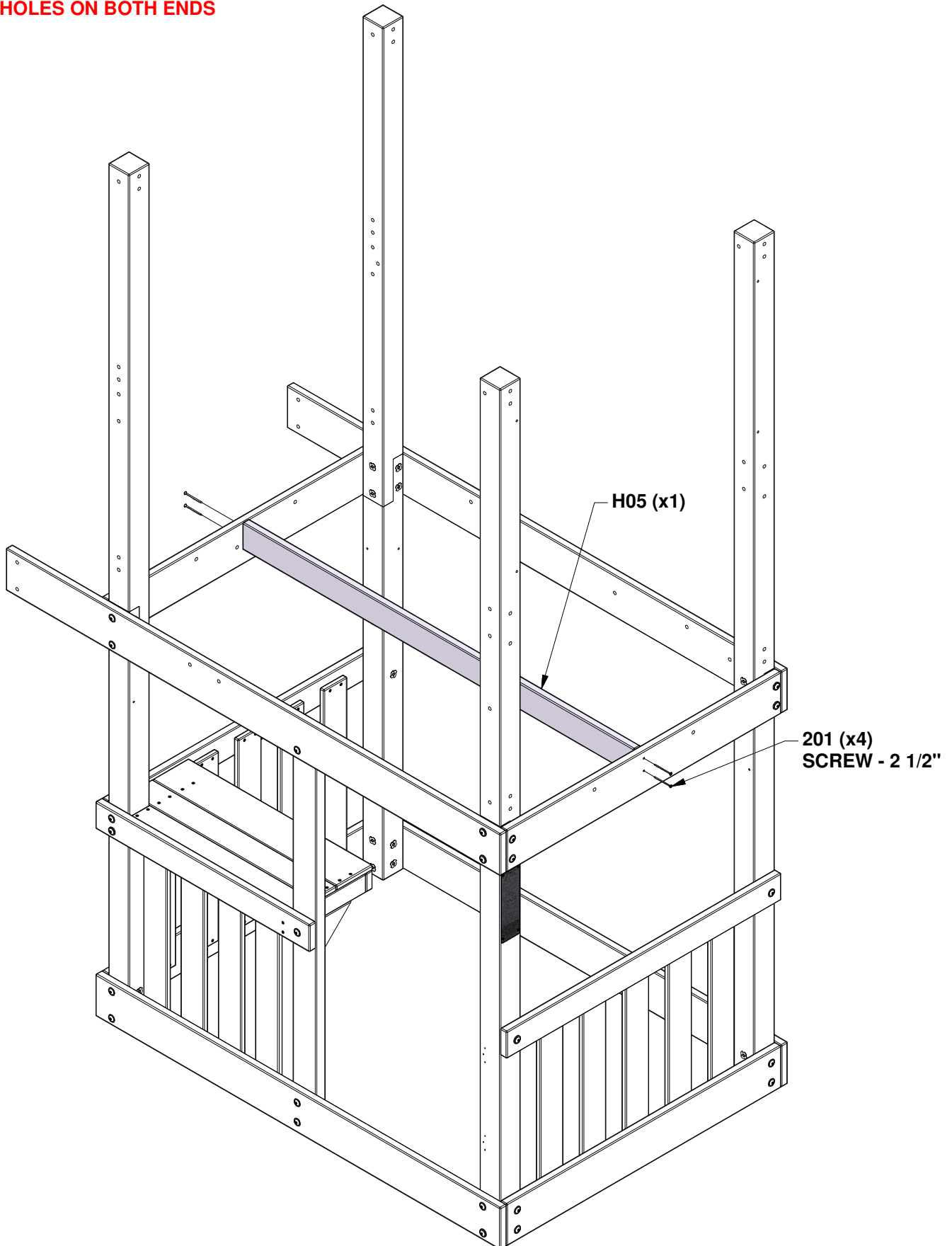

# STEP 13 - FORT ASSEMBLY

QTY	PART NUMBER	DESCRIPTION
8	H100200	SCREW PFH 8x1 1/2 BLK

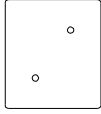

**H06 FLOOR BLOCK - W4L21378**  
**(x4) 1"x3"x3 3/8" (24x76x86)**

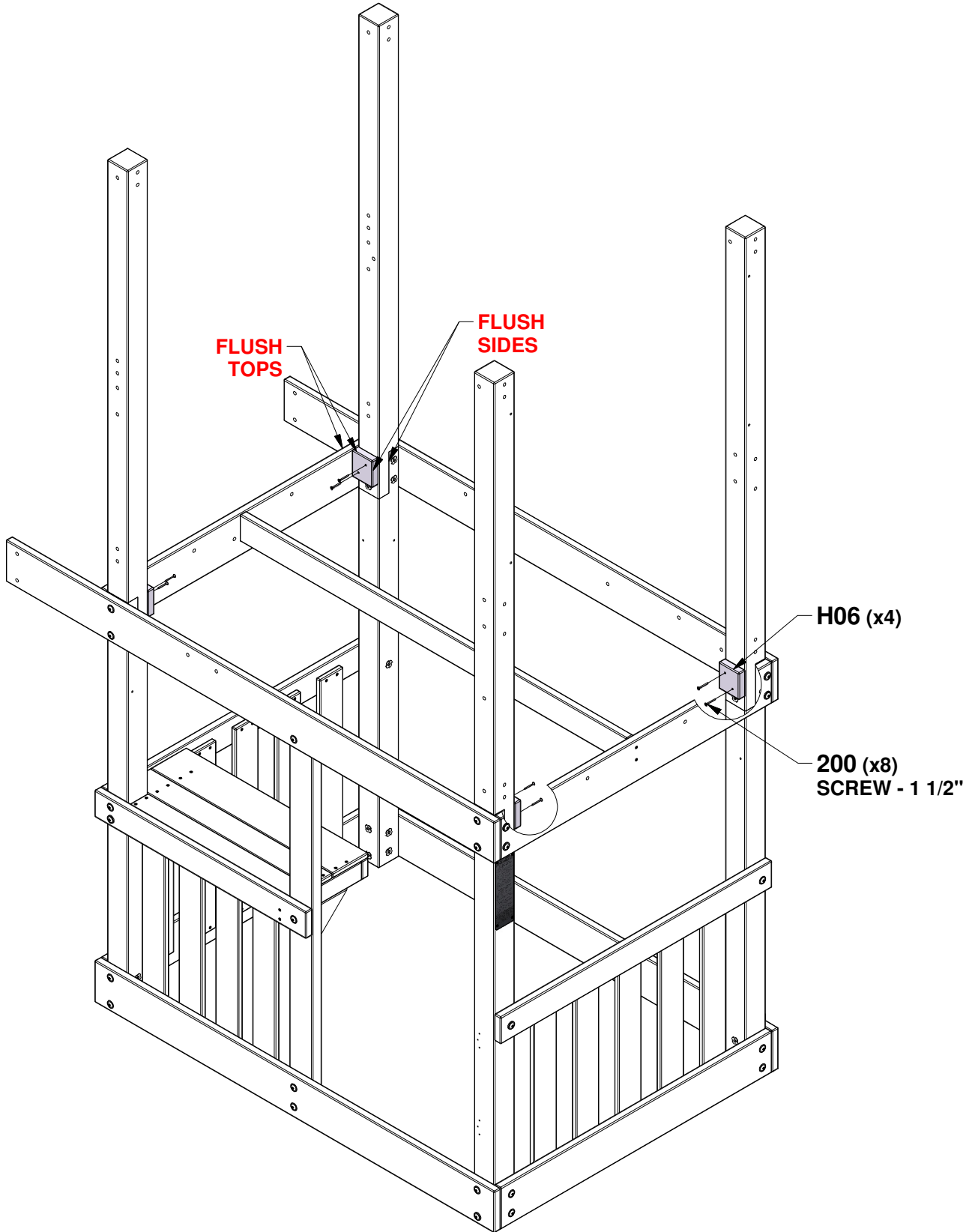

# STEP 14 - FORT ASSEMBLY



**E01 ANGLE BRACE - W4L21379**  
**(x8) 1 7/16"x3 3/8"x17 1/2" (36x86x444)**

QTY	PART NUMBER	DESCRIPTION
8	H100198	WASHER LOCK EXT 8x19 BLK
8	H100205	BOLT WH 5/16x2 1/4 BLK
8	H100379	T-NUT 5/16 BLK
8	H100405	WASHER LOCK EXT 6x15 BLK
8	H100792	LAG SCREW WH 1/4x3 BLK

## INSTALL T-NUTS IN WOOD FIRST

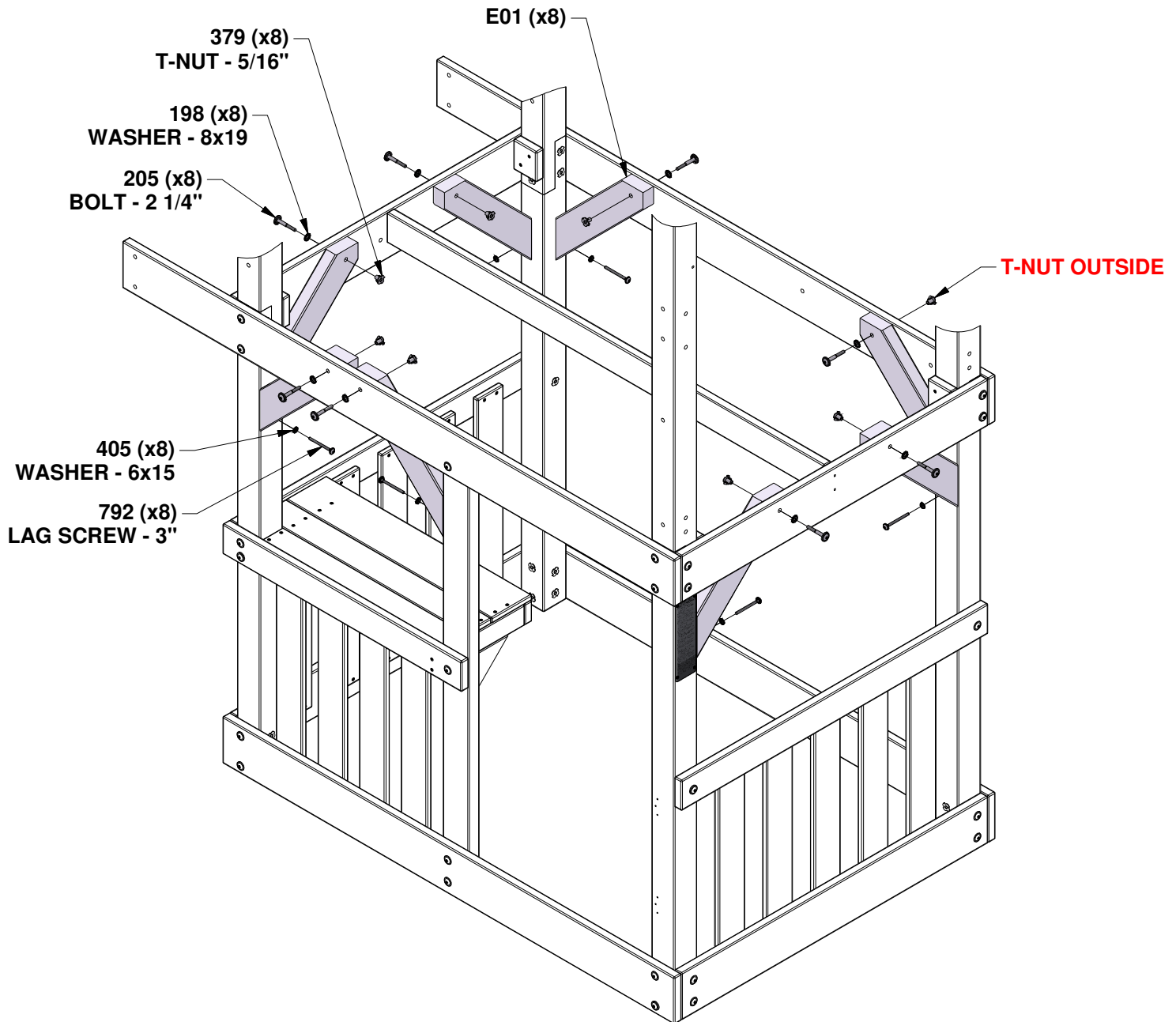

# STEP 15 - FORT ASSEMBLY

QTY	PART NUMBER	DESCRIPTION
2	H100379	T-NUT 5/16 BLK
2	H100468	BOLT WH 5/16x1 BLK
1	H100469	NUT BARREL WH 5/16x5/8 BLK
1	H100663	BOLT WH 5/16x3/4 BLK



**H20 FLOOR JOIST - W4L21407**  
(x1) 1"x3 3/8"x12 1/8" (24x86x308)

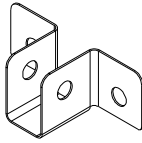

**A4M02606**  
(x1) **JOIST HANGER 90°**

## INSTALL T-NUTS IN WOOD FIRST

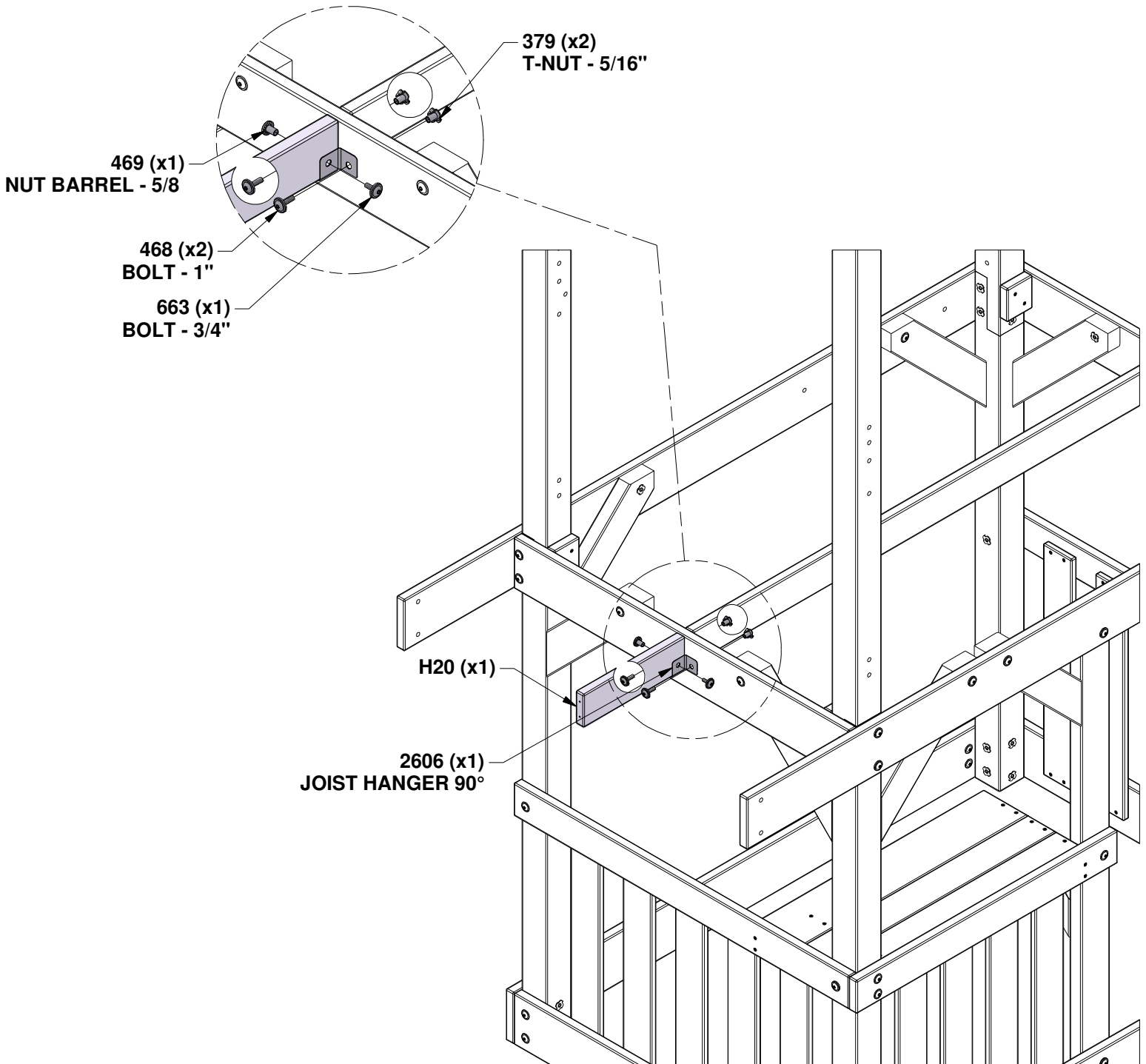

# STEP 16 - FORT ASSEMBLY

QTY	PART NUMBER	DESCRIPTION
8	H100198	WASHER LOCK EXT 8x19 BLK
2	H100201	SCREW PFH 8x2-1/2 BLK
4	H100205	BOLT WH 5/16x2-1/4 BLK
8	H100379	T-NUT 5/16 BLK
4	H100513	BOLT WH 5/16x4 1/4 BLK



**E06 UPRIGHT - W4L21417**  
(x2) 1 3/8"x3 3/8"x36 1/4" (36x86x922)

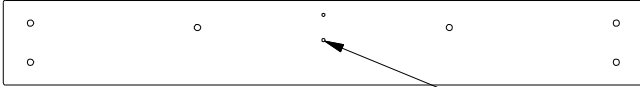

**G11 FLOOR RAIL - W4L21394**  
(x1) 1"x5 1/4"x40" (24x134x1017)

**HOLES UPWARD  
WHEN INSTALLED**

## INSTALL T-NUTS IN WOOD FIRST

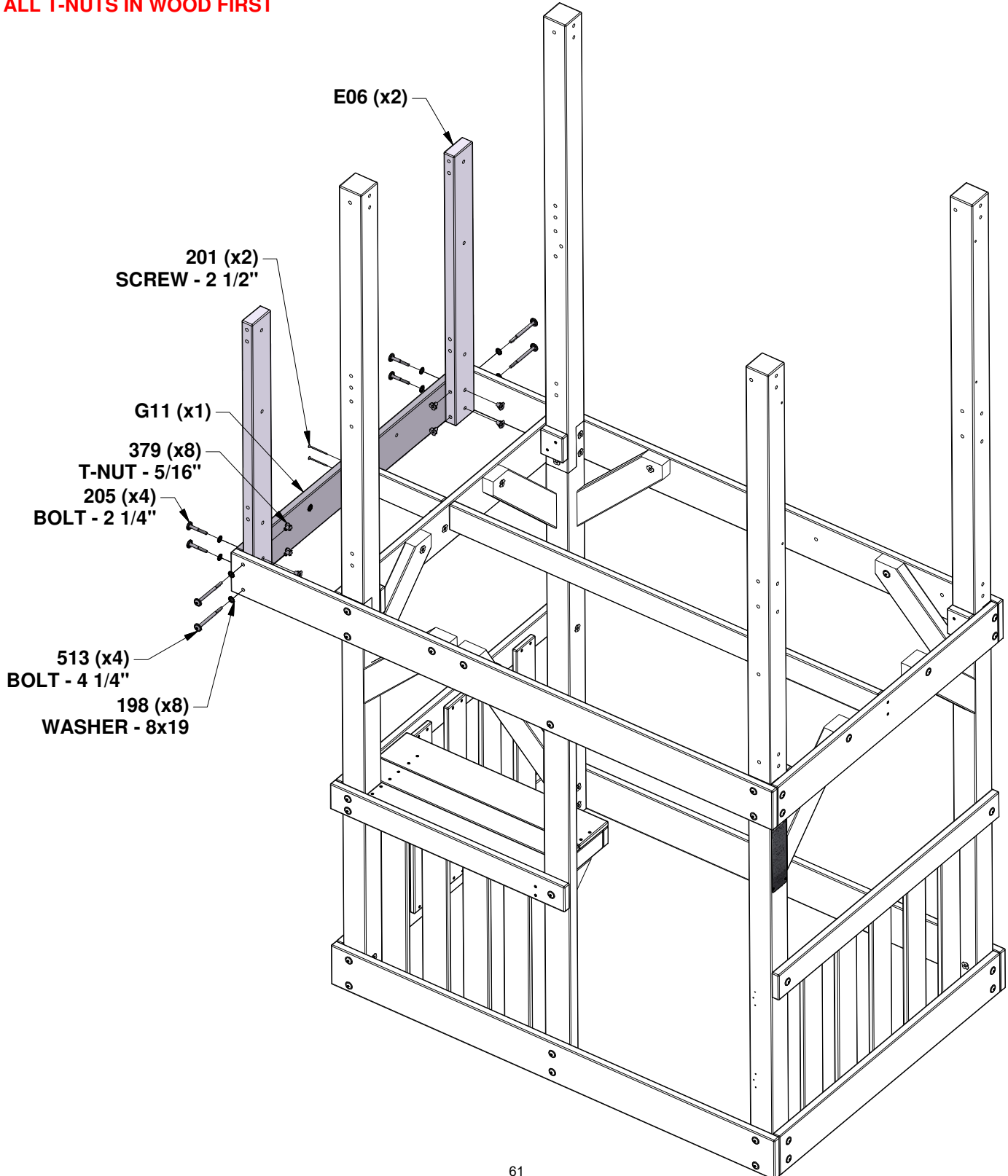

# STEP 17 - FORT ASSEMBLY



H08 WALL RAIL - W4L21387  
(x2) 1"x3 3/8"x17" (24x86x432)

QTY	PART NUMBER	DESCRIPTION
8	H100198	WASHER LOCK EXT 8x19 BLK
8	H100379	T-NUT 5/16 BLK
4	H100415	BOLT WH 5/16x3 3/4 BLK
4	H100513	BOLT WH 5/16x4 1/4 BLK

## INSTALL T-NUTS IN WOOD FIRST

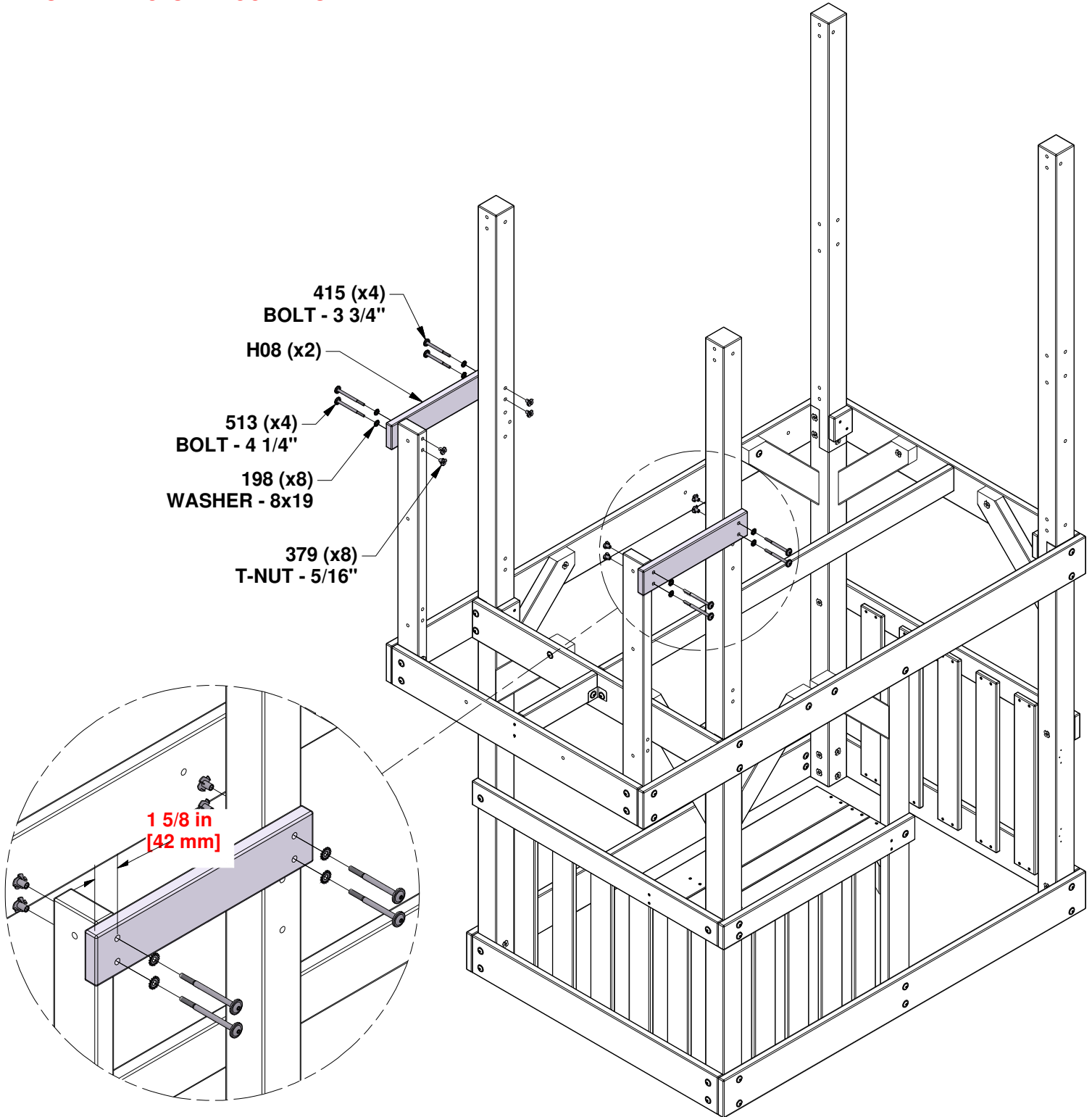

# STEP 18 - FORT ASSEMBLY

QTY	PART NUMBER	DESCRIPTION
2	H100198	WASHER LOCK EXT 8x19 BLK
2	H100205	BOLT WH 5/16x2-1/4 BLK
2	H100379	T-NUT 5/16 BLK



**H03 SLIDE RAIL - W4L21355**  
(x1) 1"x3 3/8"x40" (24x86x1017)

## INSTALL T-NUTS IN WOOD FIRST

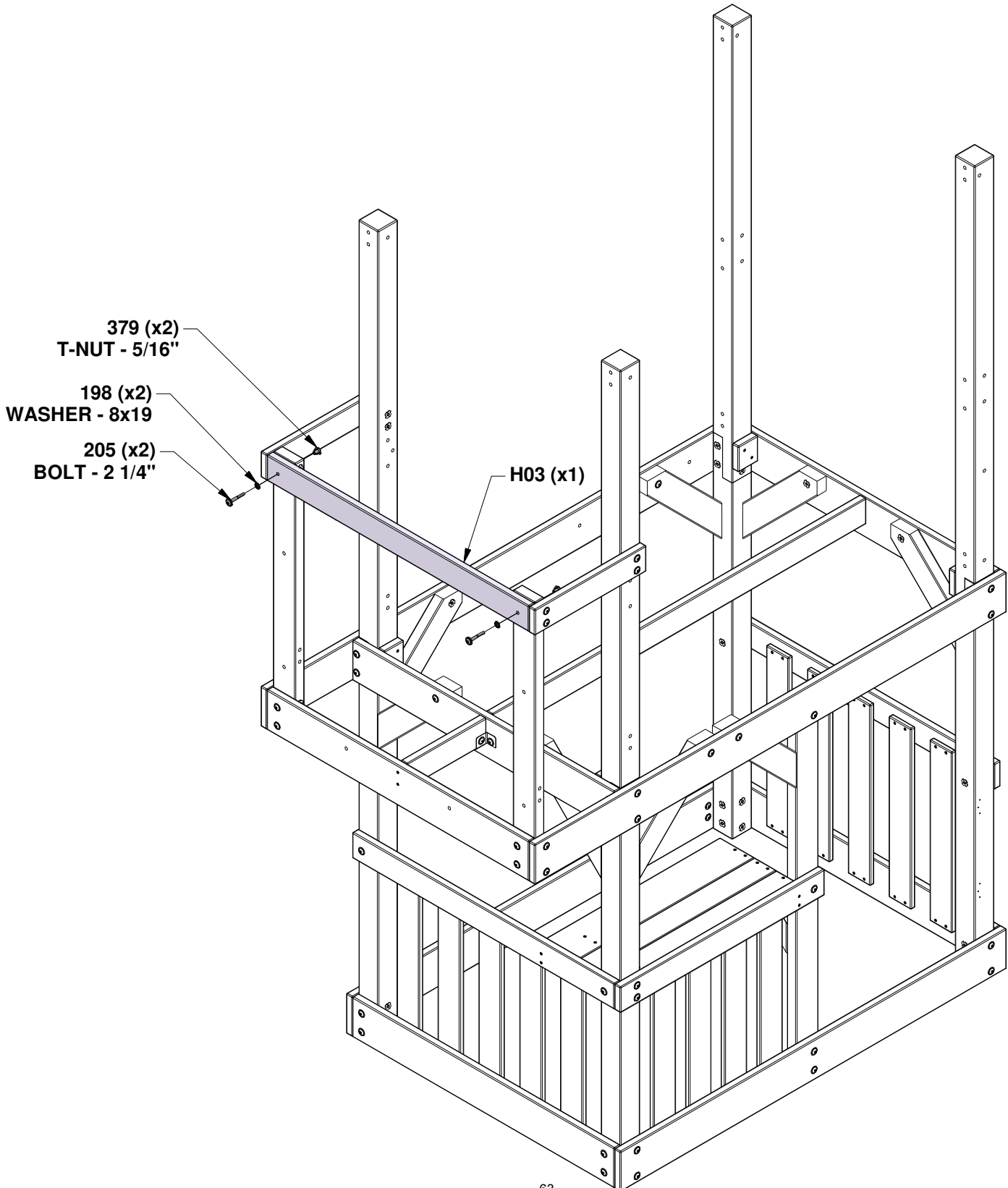

# STEP 19 - FORT ASSEMBLY

QTY	PART NUMBER	DESCRIPTION
27	H100200	SCREW PFH 8x1-1/2 BLK



**M08 FLOOR BOARD - W4L21398**  
 (x3) 5/8"x3 3/8"x41 7/8" (16x86x1065)

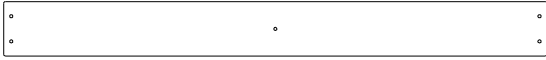

**M09 FLOOR BOARD - W4L21400**  
 (x1) 5/8"x3 3/8"x34" (16x86x863)

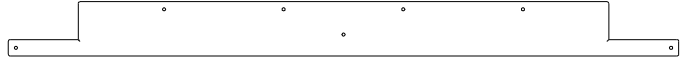

**M10 FLOOR BOARD - W4L21396**  
 (x1) 5/8"x3 3/8"x41 7/8" (16x86x1065)

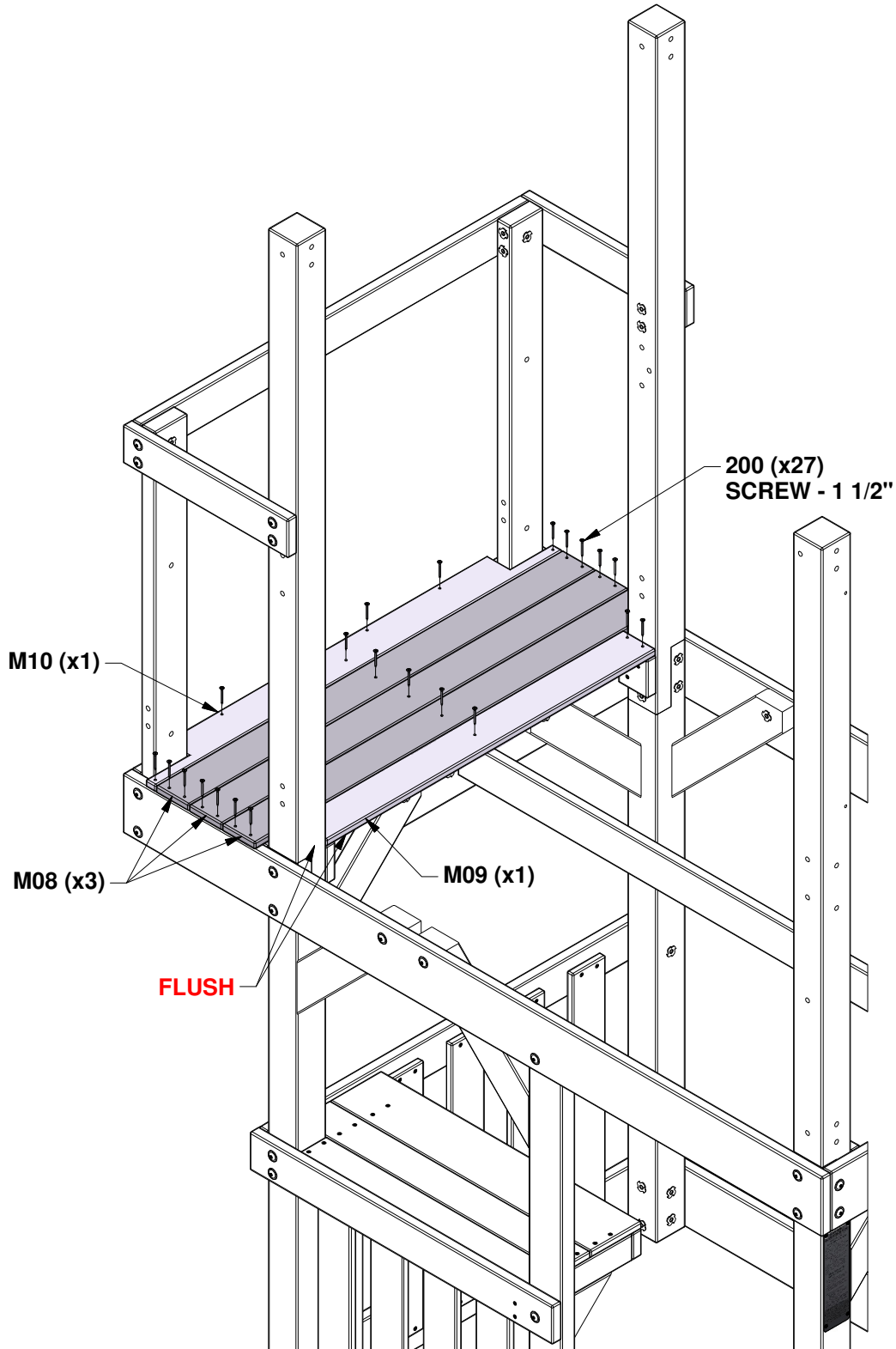

# STEP 20 - FORT ASSEMBLY



H16 WALL RAIL - W4L21354  
(x2) 1"x3 3/8"x16 1/8" (24x86x408)

QTY	PART NUMBER	DESCRIPTION
8	H100198	WASHER LOCK EXT 8x19 BLK
8	H100379	T-NUT 5/16 BLK
4	H100415	BOLT WH 5/16x3 3/4 BLK
4	H100513	BOLT WH 5/16x4 1/4 BLK

## INSTALL T-NUTS IN WOOD FIRST

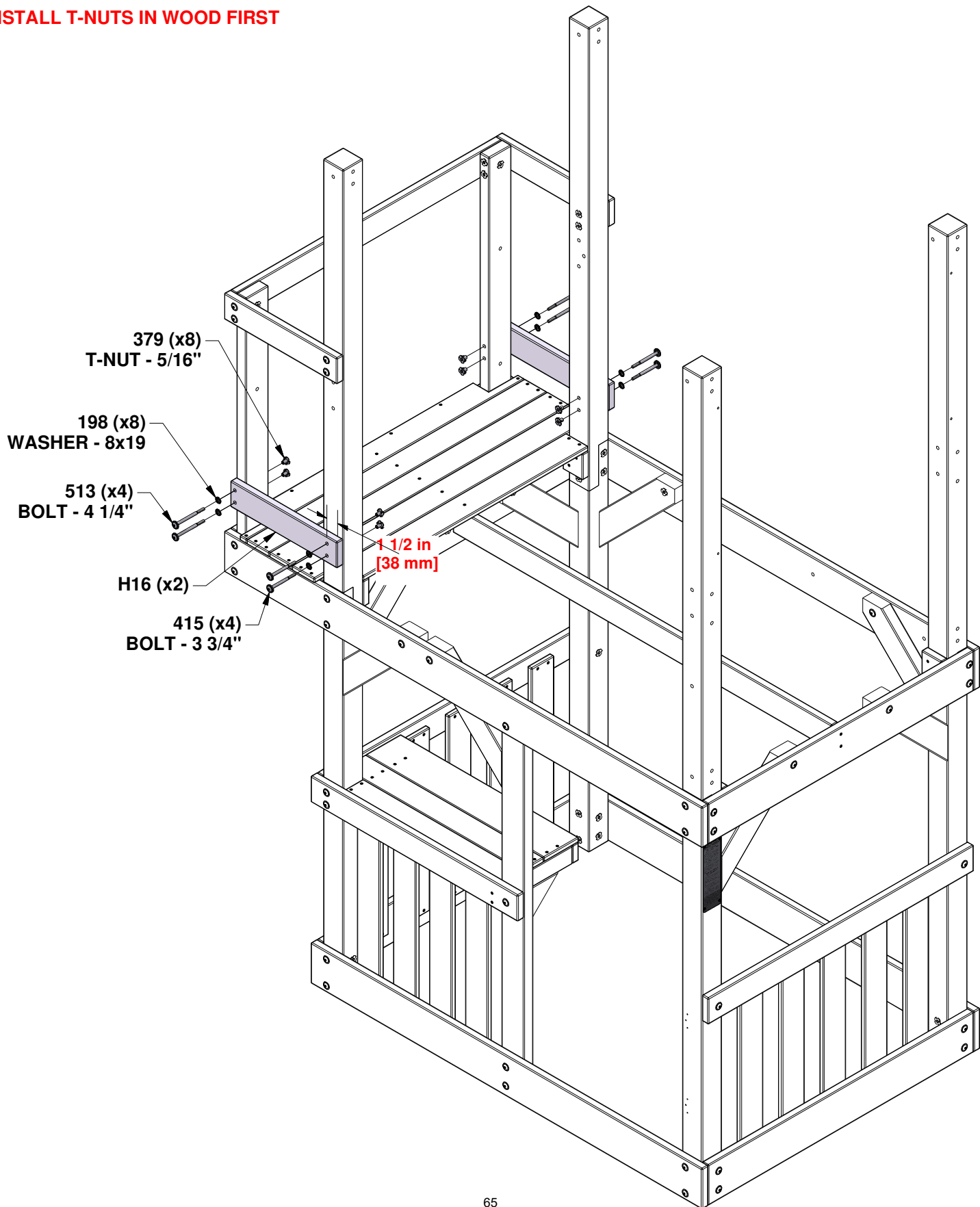

# STEP 21 - FORT ASSEMBLY

QTY	PART NUMBER	DESCRIPTION
82	H100200	SCREW PFH 8x1-1/2 BLK



**M04 FLOOR BOARD - W4L21381**  
(x15) 5/8"x3 3/8"x41 7/8" (16x86x1065)



**Y01 FLOOR BOARD - W4L21380**  
(x1) 5/8"x3 7/8"x34" (16x100x864)

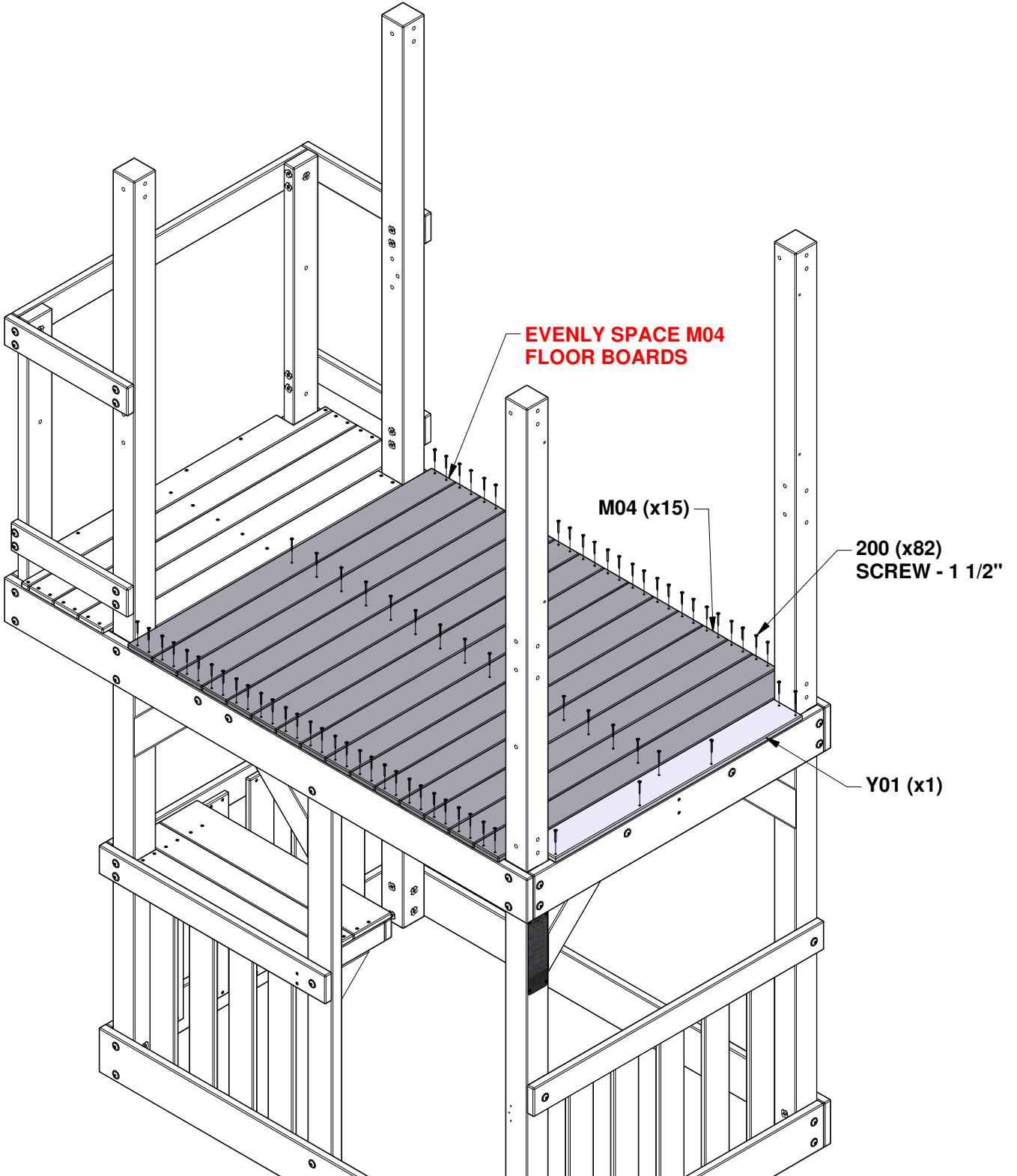

# STEP 22 - FORT ASSEMBLY

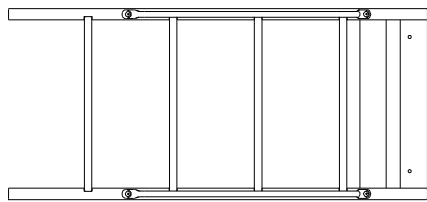

(x1) LADDER ASSEMBLY



G13 GROUND BOARD - W4L21349  
(x1) 1"x5 1/4"x24 3/8" (24x134x618)

QTY	PART NUMBER	DESCRIPTION
2	H100192	NUT BARREL WH 5/16x7/8 BLK
1	H100194	BOLT WH 5/16x2-1/2 BLK
2	H100198	WASHER LOCK EXT 8x19 BLK
2	H100199	WASHER LOCK EXT 12x19 BLK
2	H100378	BOLT WH 5/16x1 3/4 BLK
3	H100379	T-NUT 5/16 BLK
2	H100396	BOLT WH 5/16x1/2 BLK

## INSTALL T-NUTS IN WOOD FIRST

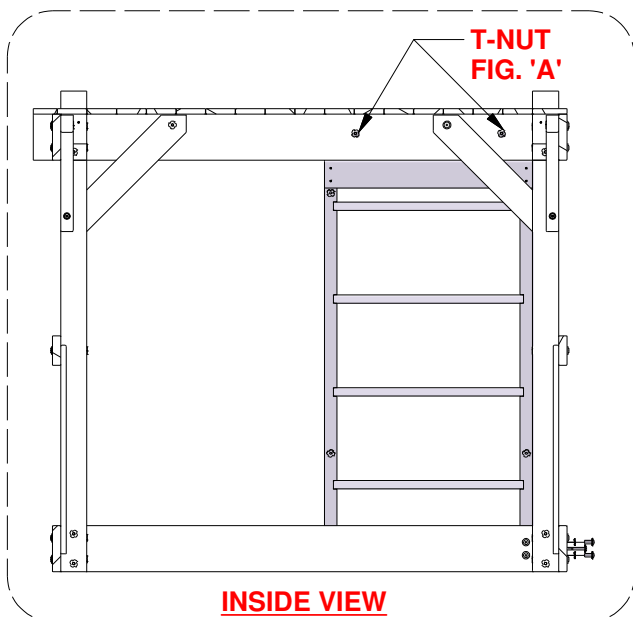
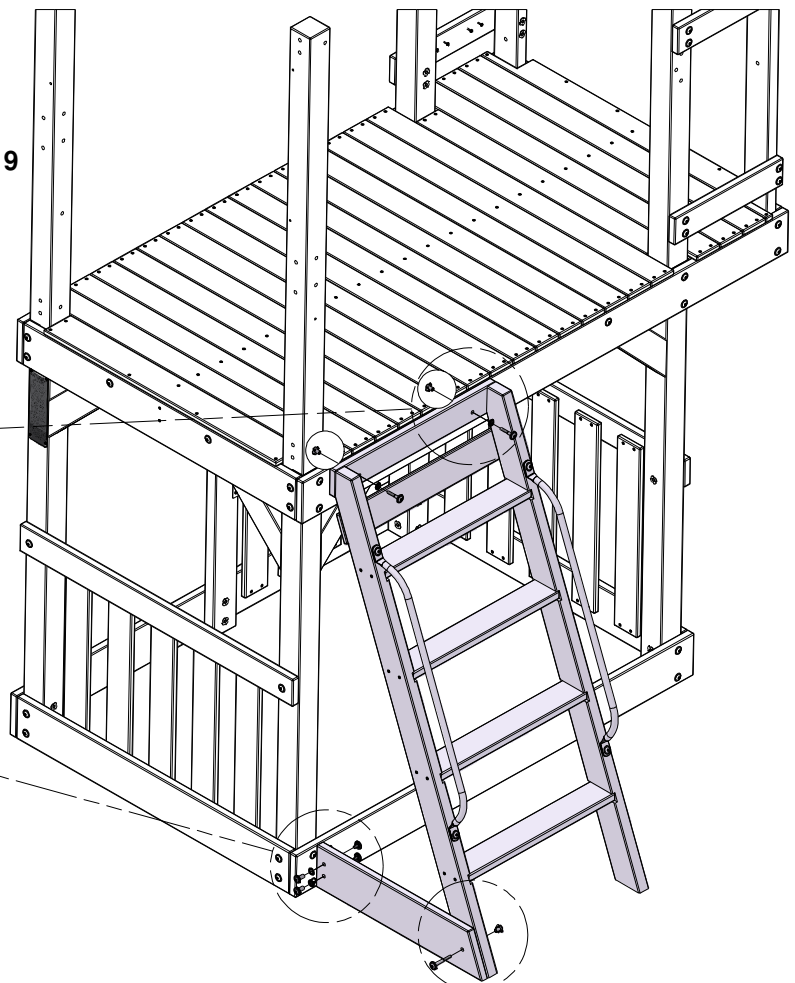
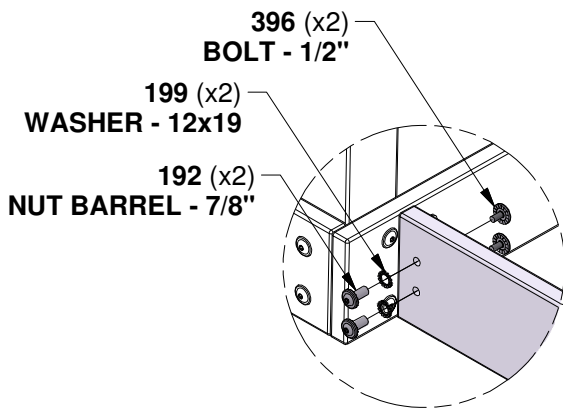
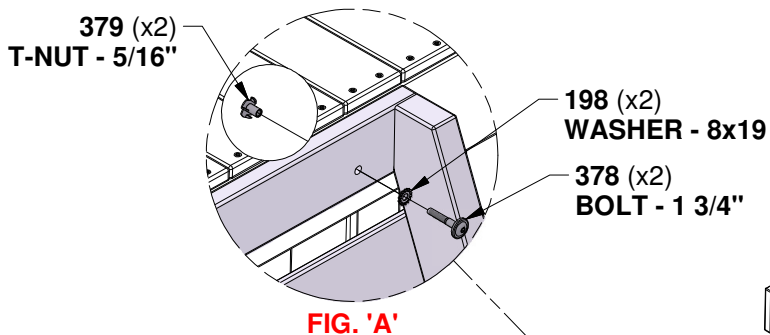

**USING G13 AS A TEMPLATE,  
DRILL A 3/8" [10mm] HOLE  
FOR HARDWARE.  
HAND TIGHTEN ONLY.**

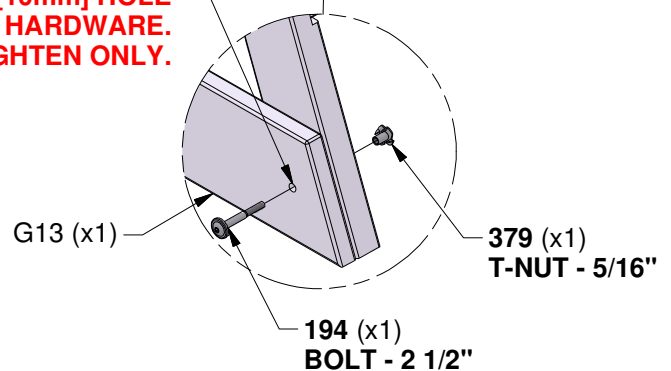

# STEP 23 - FORT ASSEMBLY

QTY	PART NUMBER	DESCRIPTION
4	H100198	WASHER LOCK EXT 8x19 BLK
4	H100379	T-NUT 5/16 BLK
4	H100415	BOLT WH 5/16x3 3/4 BLK



**H07 WALL RAIL - W4L21382**  
**(x1) 1"x3 3/8"x40" (24x86x1017)**

## INSTALL T-NUTS IN WOOD FIRST

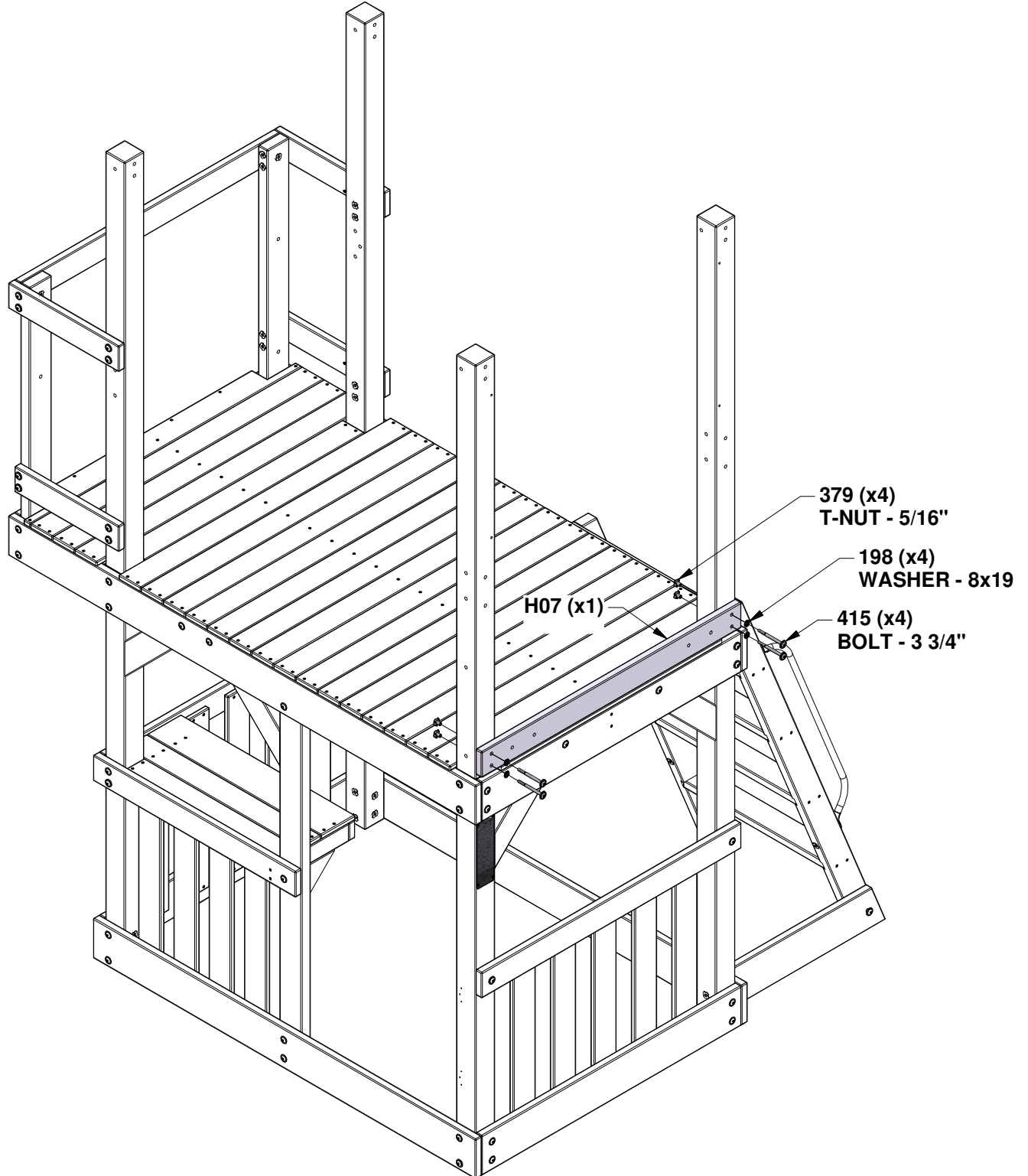

# STEP 24 - FORT ASSEMBLY

**TOP**



**C01 TOP SWING BEAM RAIL - W4L21390**  
(x1) 1 3/8"x6 3/4"x40" (36x172x1017)

QTY	PART NUMBER	DESCRIPTION
8	H100198	WASHER LOCK EXT 8x19 BLK
8	H100379	T-NUT 5/16 BLK
4	H100415	BOLT WH 5/16x3 3/4 BLK
4	H100513	BOLT WH 5/16x4 1/4 BLK



**G12 FRONT ARCHED RAIL - W4L21388**  
(x1) 1"x5 1/4"x58 1/2" (24x134x1486)

**INSTALL T-NUTS IN WOOD FIRST**

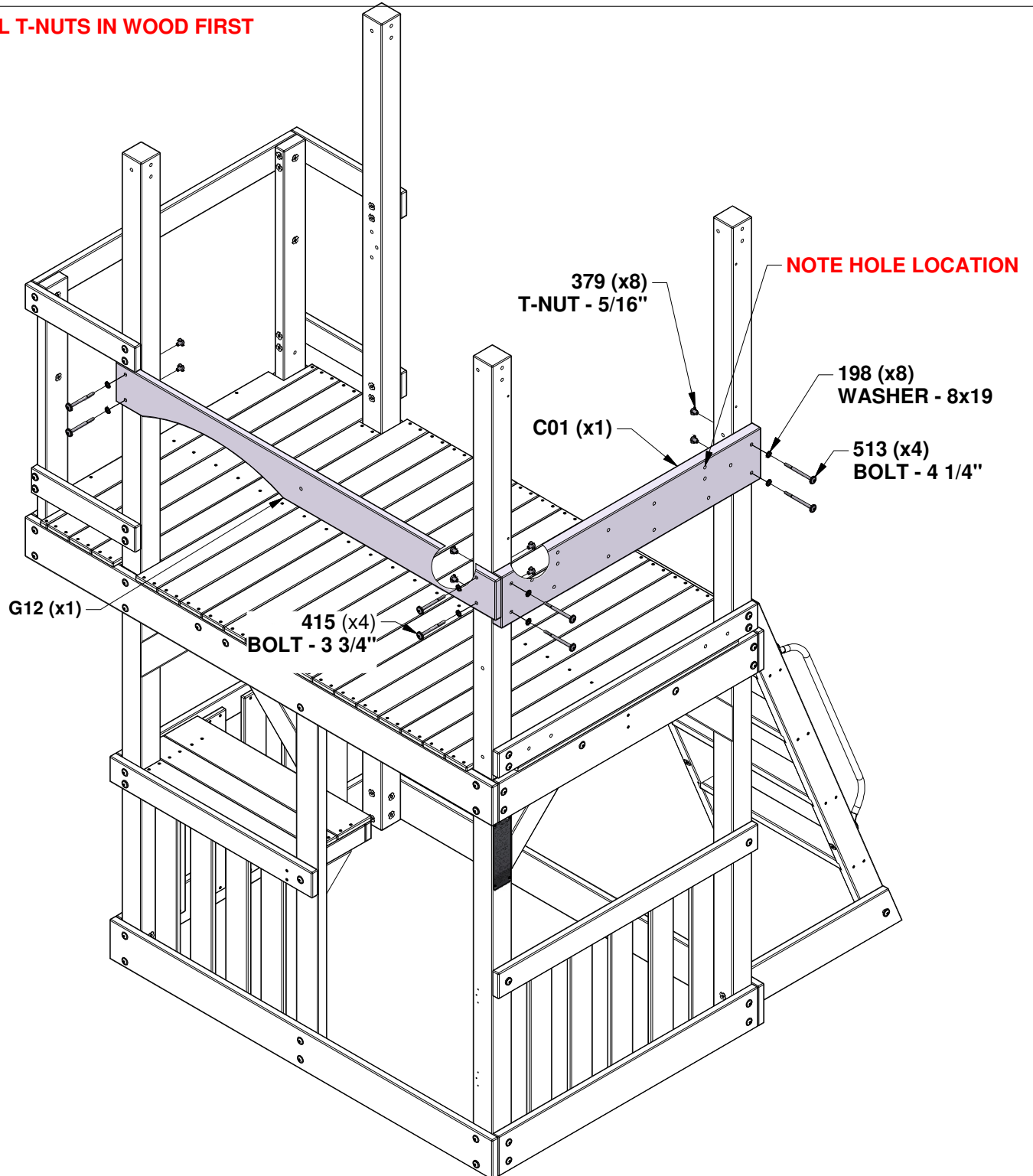

# STEP 25 - FORT ASSEMBLY

QTY	PART NUMBER	DESCRIPTION
4	H100198	WASHER LOCK EXT 8x19 BLK
4	H100379	T-NUT 5/16 BLK
4	H100415	BOLT WH 5/16x3 3/4 BLK

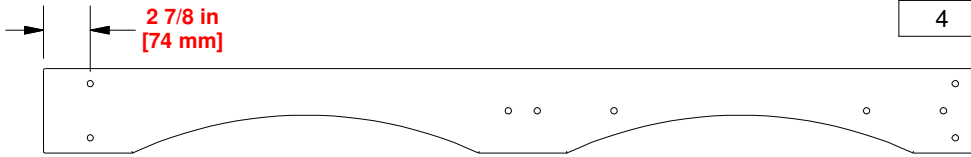

**G08 BACK ARCHED RAIL - W4L21389**  
(x1) 1"x5 1/4"x58 1/2" (24x134x1486)

## INSTALL T-NUTS IN WOOD FIRST

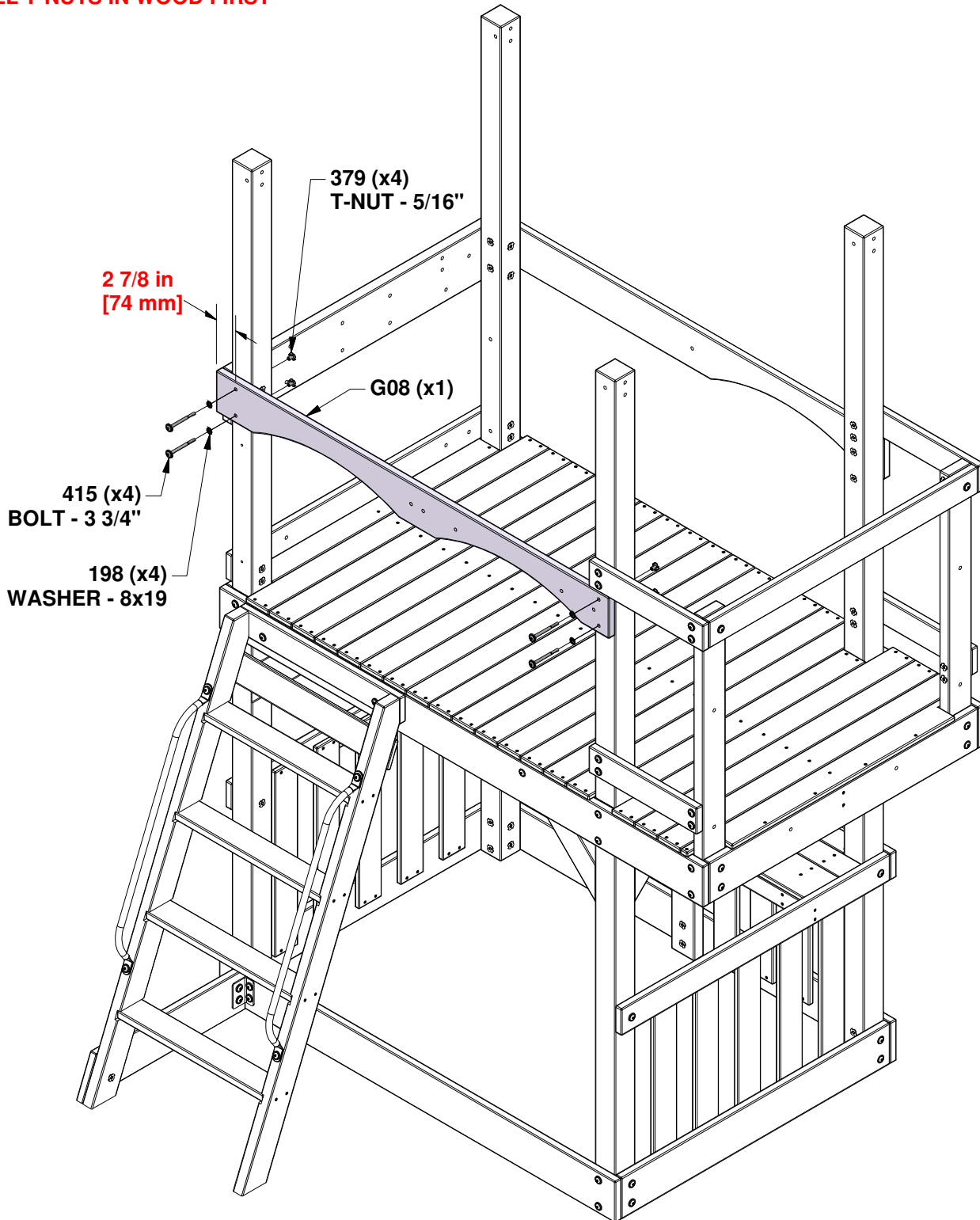

# STEP 26 - FORT ASSEMBLY

QTY	PART NUMBER	DESCRIPTION
16	H100387	SCREW PFH 8x1 1/4 BLK



**M01 PICKET - W4L21369**  
(x4) 5/8"x3 3/8"x23 7/8" (16x86x606)

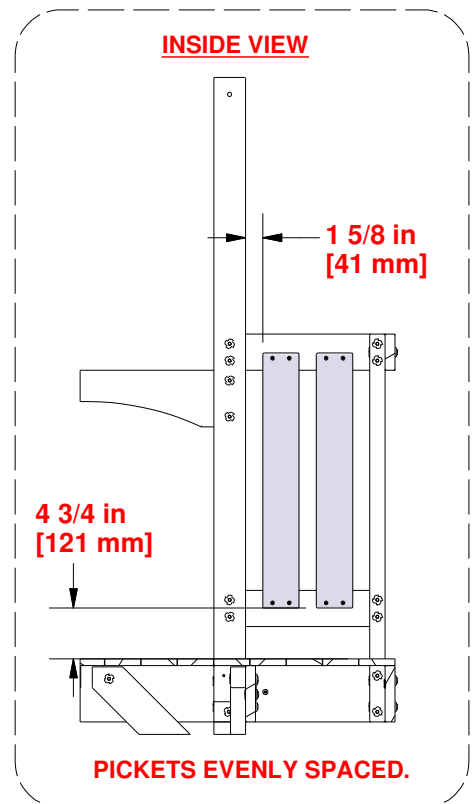
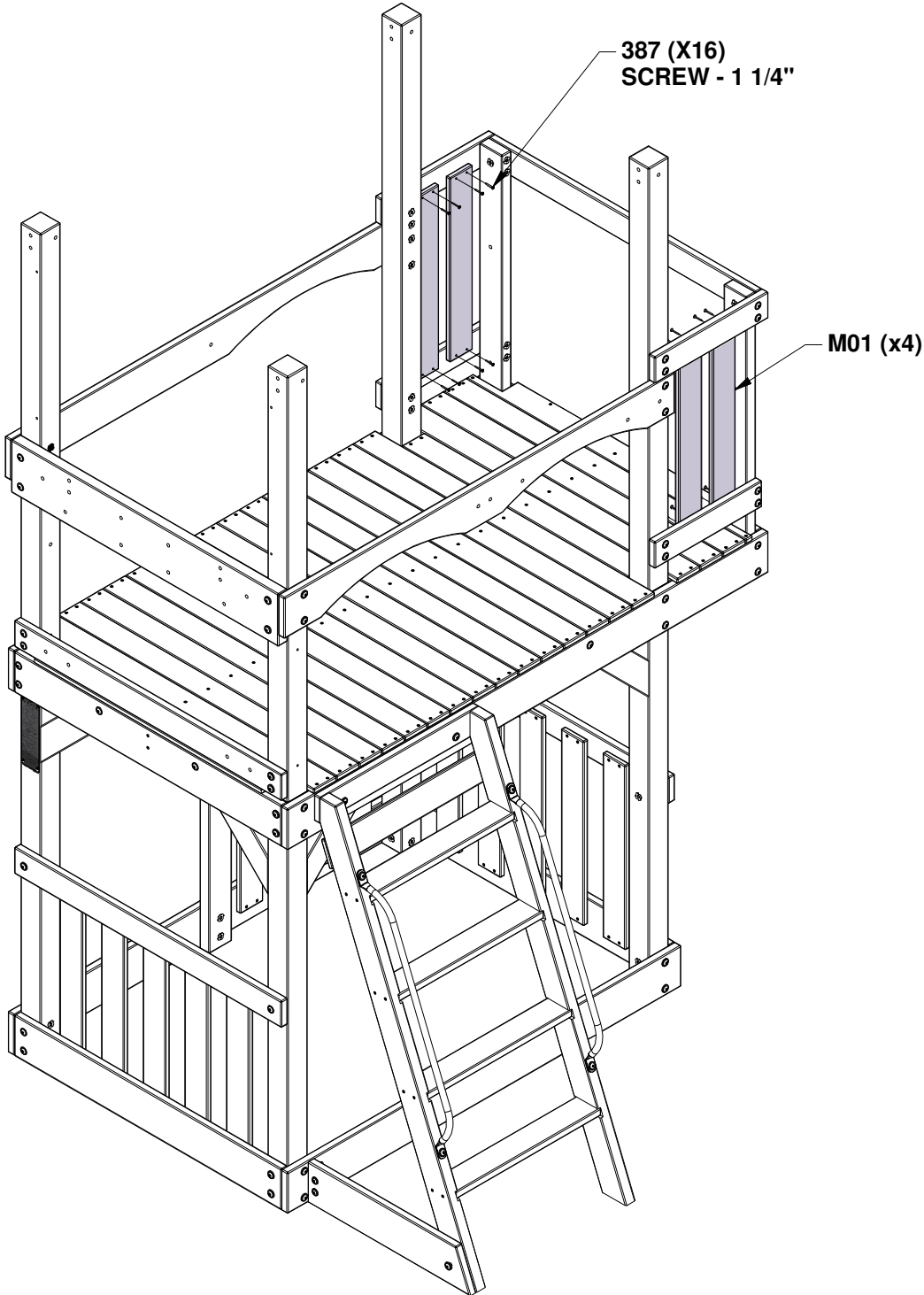

# STEP 27 - FORT ASSEMBLY

QTY	PART NUMBER	DESCRIPTION
1	H100192	NUT BARREL WH 5/16x7/8 BLK
4	H100198	WASHER LOCK EXT 8x19 BLK
1	H100199	WASHER LOCK EXT 12x19 BLK
2	H100378	BOLT WH 5/16x1 3/4 BLK
5	H100379	T-NUT 5/16 BLK
1	H100396	BOLT WH 5/16x1/2 BLK
1	H100407	BOLT WH 5/16x1 1/2 BLK
2	H100415	BOLT WH 5/16x3 3/4 BLK

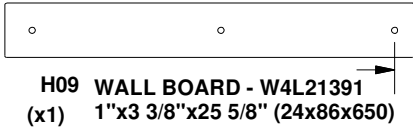

1 1/4 in  
[31 mm]



A4M01047 L BRACKET  
(x1) 2.5x38x55x55



1 3/4 in  
[43 mm]

1 1/2 in  
[38 mm]

H15 WALL BOARD - W4L21353  
(x2) 1"x3 3/8"x30 1/4" (24x86x768)

## INSTALL T-NUTS IN WOOD FIRST

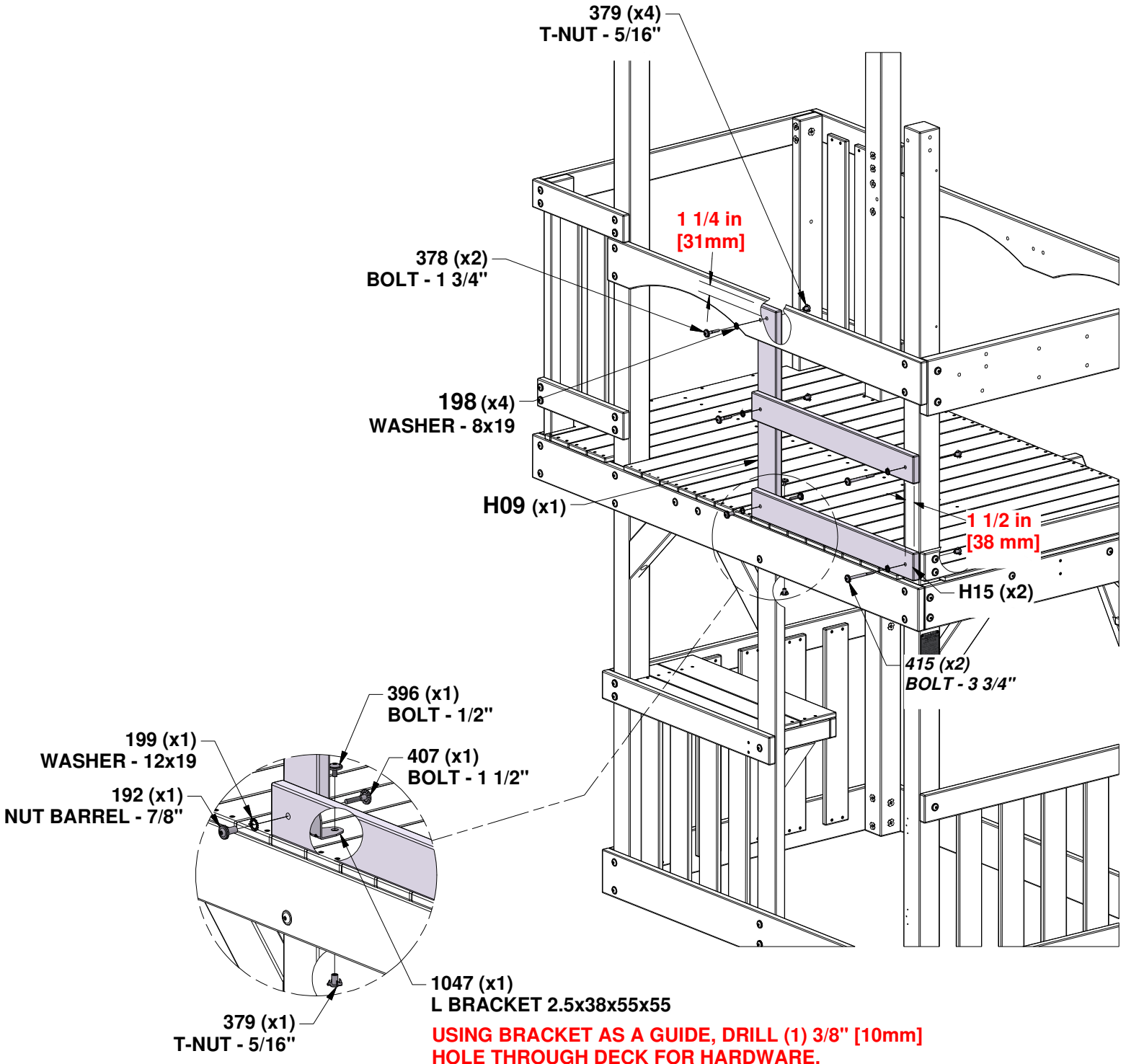

# STEP 28 - FORT ASSEMBLY

QTY	PART NUMBER	DESCRIPTION
1	H100378	BOLT WH 5/16x1 3/4 BLK
1	H100198	WASHER LOCK EXT 8x19 BLK
2	H100379	T-NUT 5/16 BLK
2	H100396	BOLT WH 5/16x1/2 BLK
1	H100199	WASHER LOCK EXT 12x19 BLK
1	H100192	NUT BARREL WH 5/16x7/8 BLK



**H13 WALL BOARD - W4L21397**  
(x1) 1"x3 3/8"x25 5/8" (24x86x650)



**A4M01047 L BRACKET**  
(x1) 2.5x38x55x55

## INSTALL T-NUTS IN WOOD FIRST

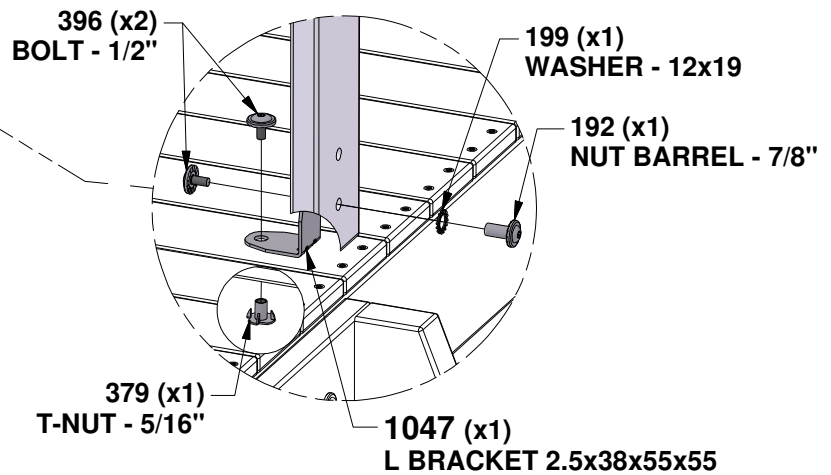
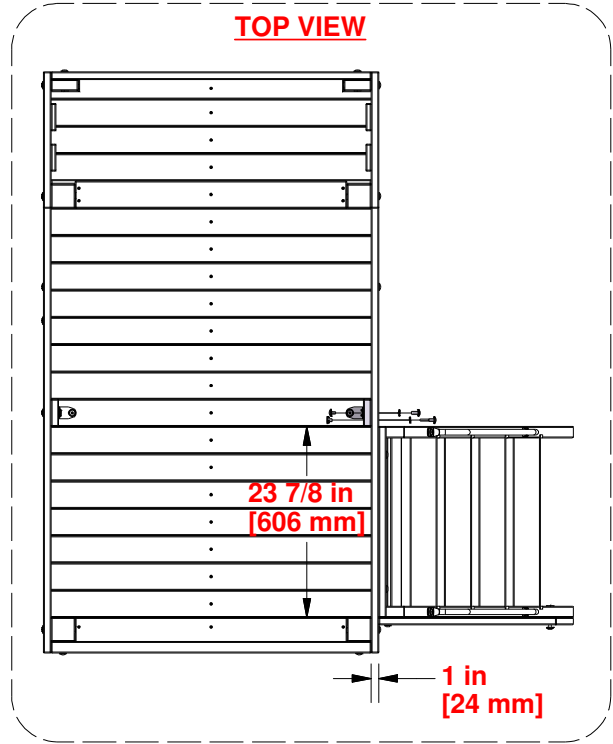
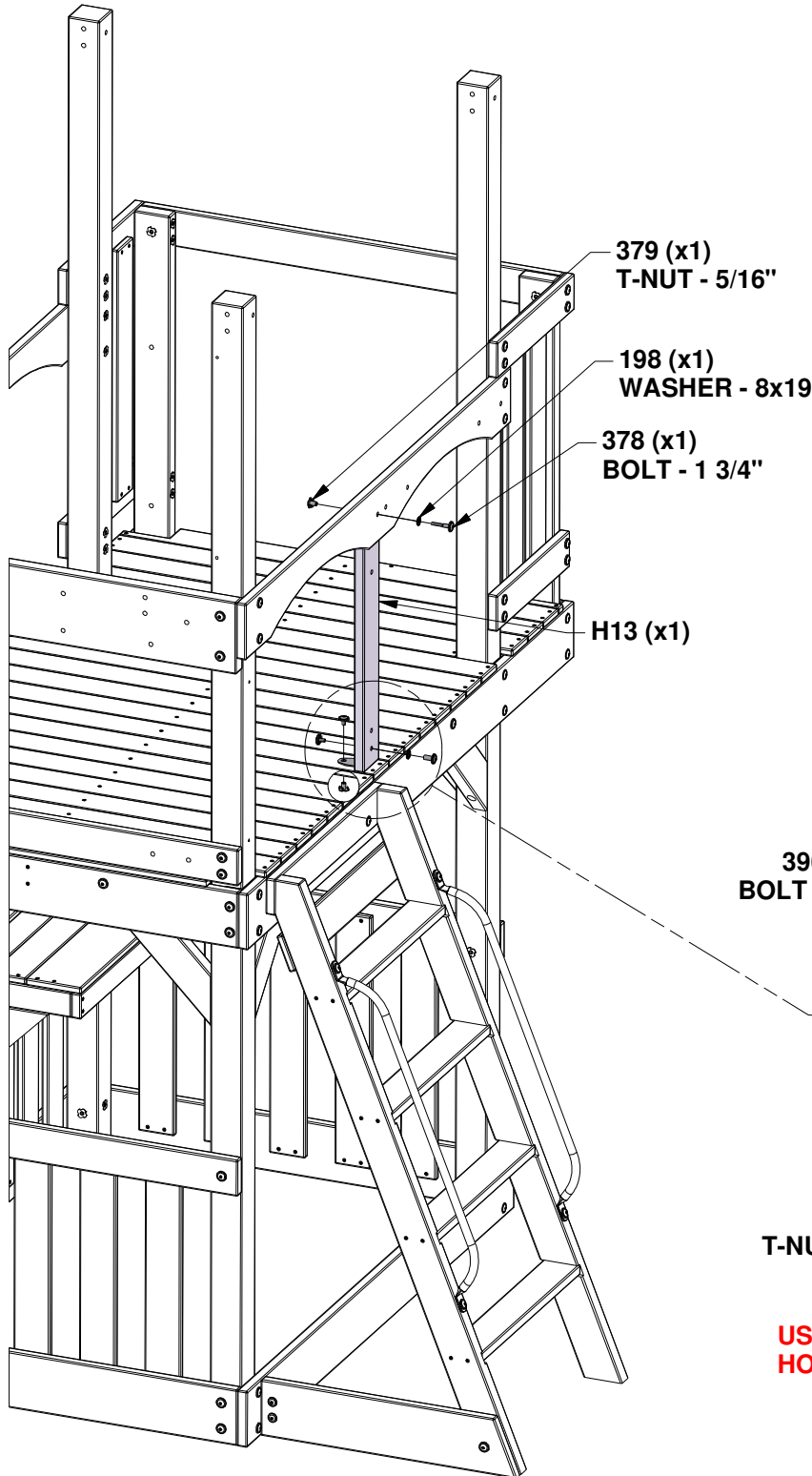

**USING BRACKET AS A GUIDE, DRILL (1) 3/8" [10mm] HOLE THROUGH DECK FOR HARDWARE.**

# STEP 29 - FORT ASSEMBLY

QTY	PART NUMBER	DESCRIPTION
4	H100198	WASHER LOCK EXT 8x19 BLK
4	H100379	T-NUT 5/16 BLK
4	H100415	BOLT WH 5/16x3 3/4 BLK



**AD02 WALL RAIL - W4L21401**  
 (x2) 1"x3 7/8"x65 3/4" (24x100x1670)

## INSTALL T-NUTS IN WOOD FIRST

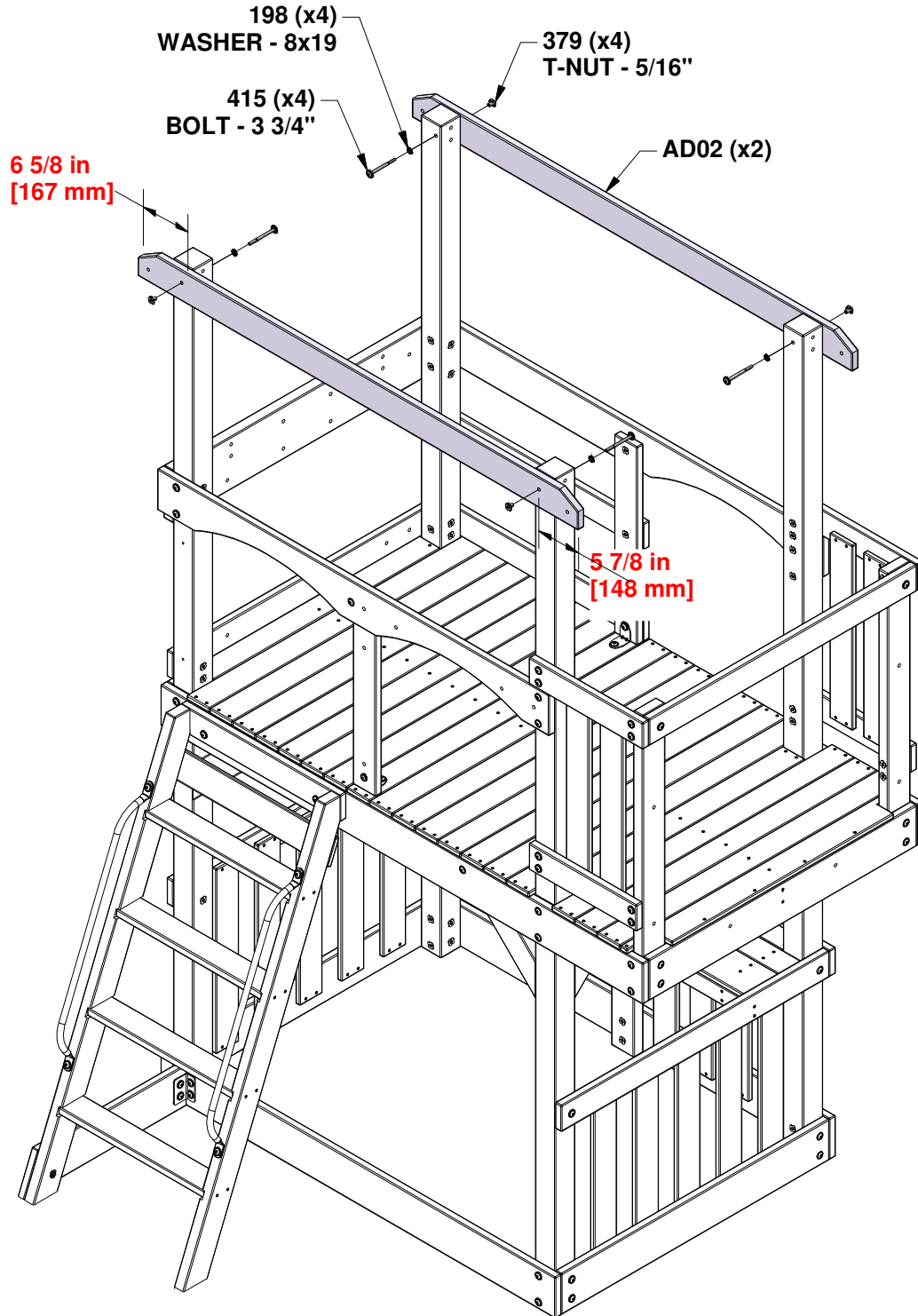

# STEP 30 - FORT ASSEMBLY

QTY	PART NUMBER	DESCRIPTION
8	H100198	WASHER LOCK EXT 8x19 BLK
8	H100379	T-NUT 5/16 BLK
4	H100415	BOLT WH 5/16x3 3/4 BLK
4	H100503	BOLT WH 5/16x3 1/2 BLK

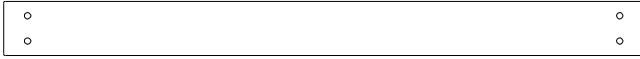

**M07 WALL RAIL - W4L21395**  
(x1) 5/8"x3 3/8"x40" (16x86x1017)



**H07 WALL RAIL - W4L21382**  
(x1) 1"x3 3/8"x40" (24x86x1017)

## INSTALL T-NUTS IN WOOD FIRST

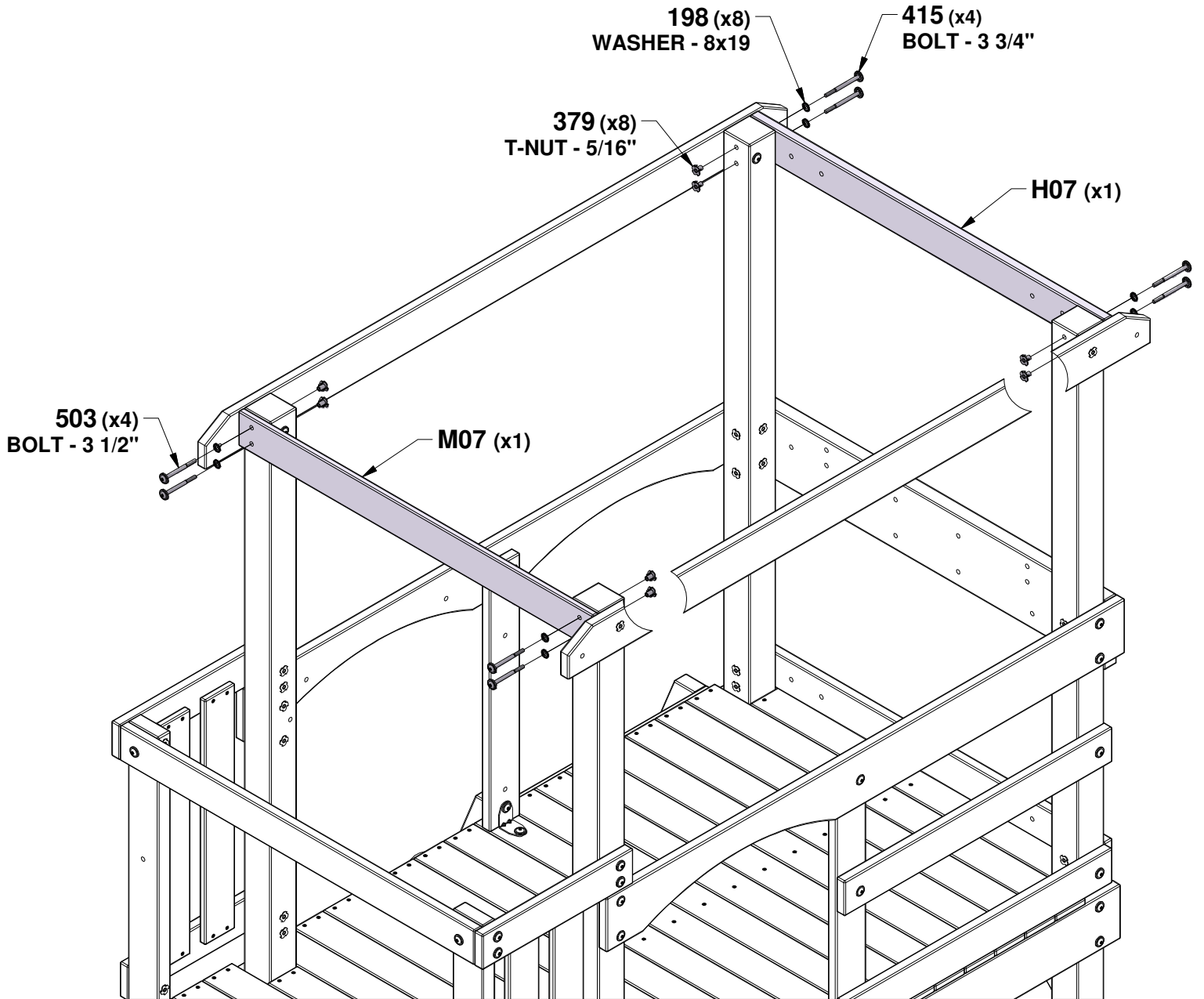

# STEP 31 - FORT ASSEMBLY

QTY	PART NUMBER	DESCRIPTION
28	H100387	SCREW PFH 8x1 1/4 BLK



M14 WALL BOARD - W4L21352  
(x7) 5/8"x3 3/8"x11 3/4" (16x86x300)

## INSIDE VIEW

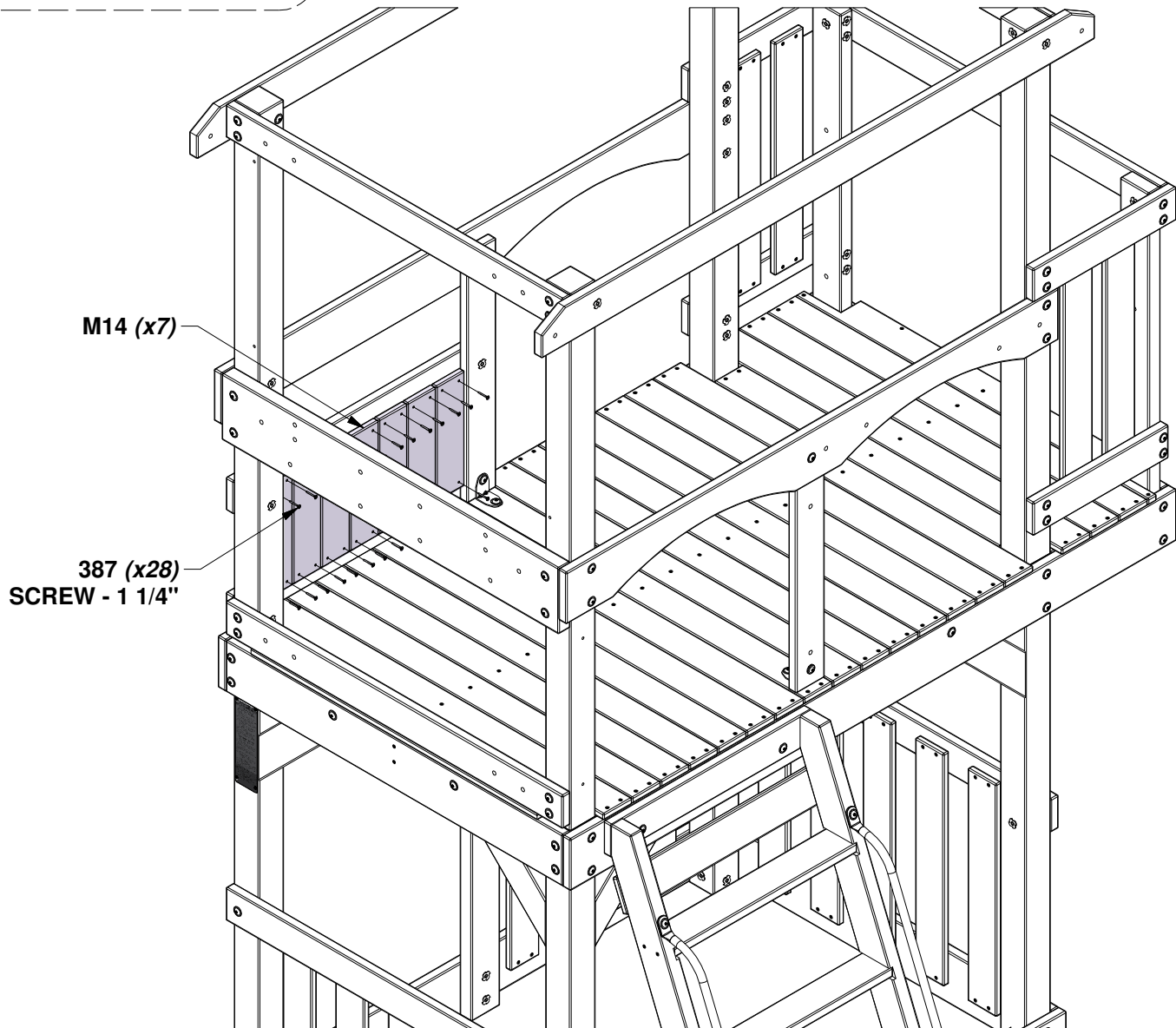
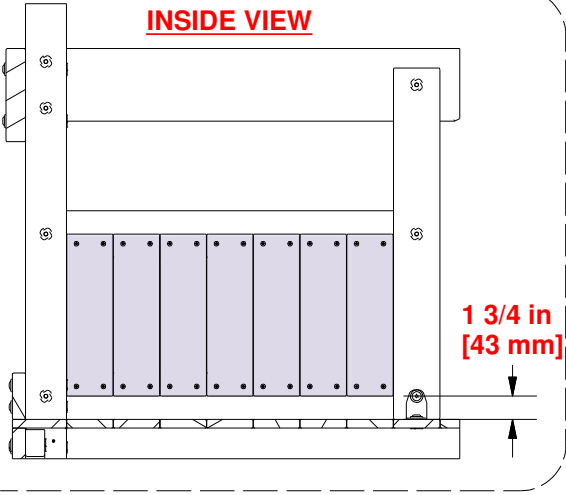

# STEP 32 - FORT ASSEMBLY

QTY	PART NUMBER	DESCRIPTION
10	H100382	SCREW PFH 8x1 3/4 BLK
5	H100395	SCREW PFH 8x3/4 BLK



**S01 WINDOW FRAME - W4L21351**  
 (x1) 1"x1"x23 7/8" (24x24x605)



**S02 WINDOW FRAME - W4L21350**  
 (x5) 1"x1"x9 3/8" (24x24x237)

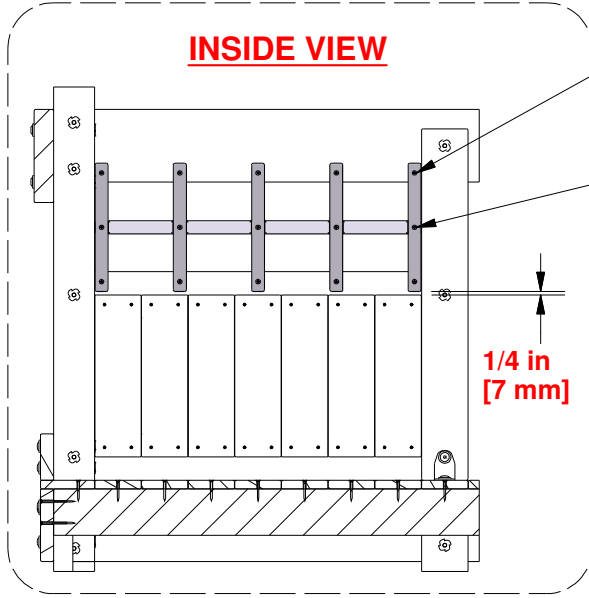

**382**  
**SCREW - 1 3/4"**  
**TOP & BOTTOM ROW**

**395**  
**SCREW - 3/4"**  
**MIDDLE ROW**

**1/4 in**  
**[7 mm]**

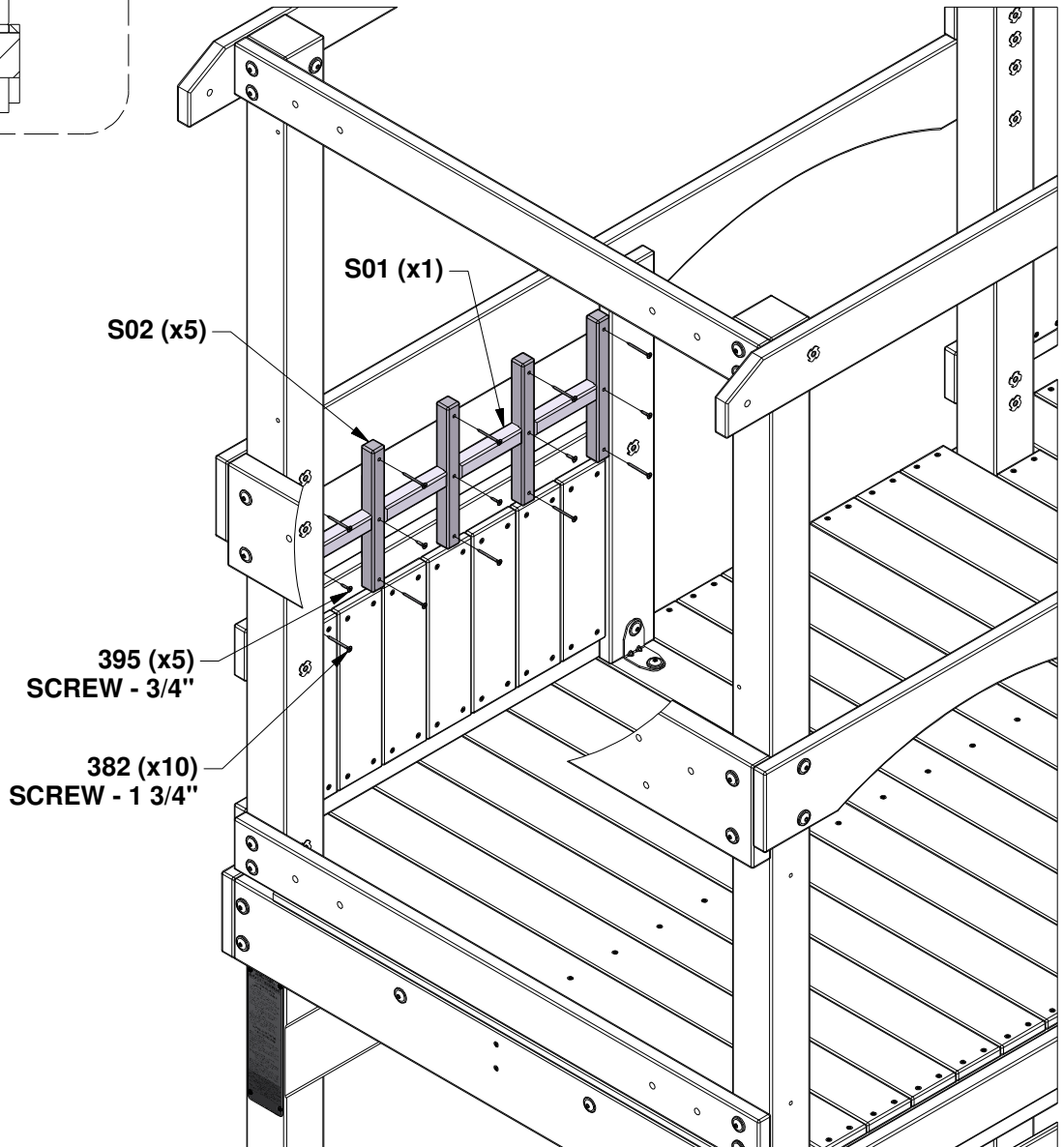

# STEP 33 - FORT ASSEMBLY

QTY	PART NUMBER	DESCRIPTION
14	H100200	SCREW PFH 8x1-1/2 BLK

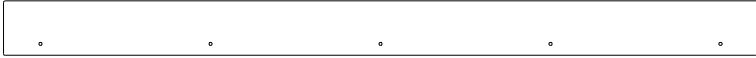

**H10 WINDOW TRIM - W4L21392**  
(x2) 1"x3 3/8"x47 1/8" (24x86x1198)



**J05 WINDOW TRIM - W4L21393**  
(x2) 1"x2"x26 1/4" (24x50x668)

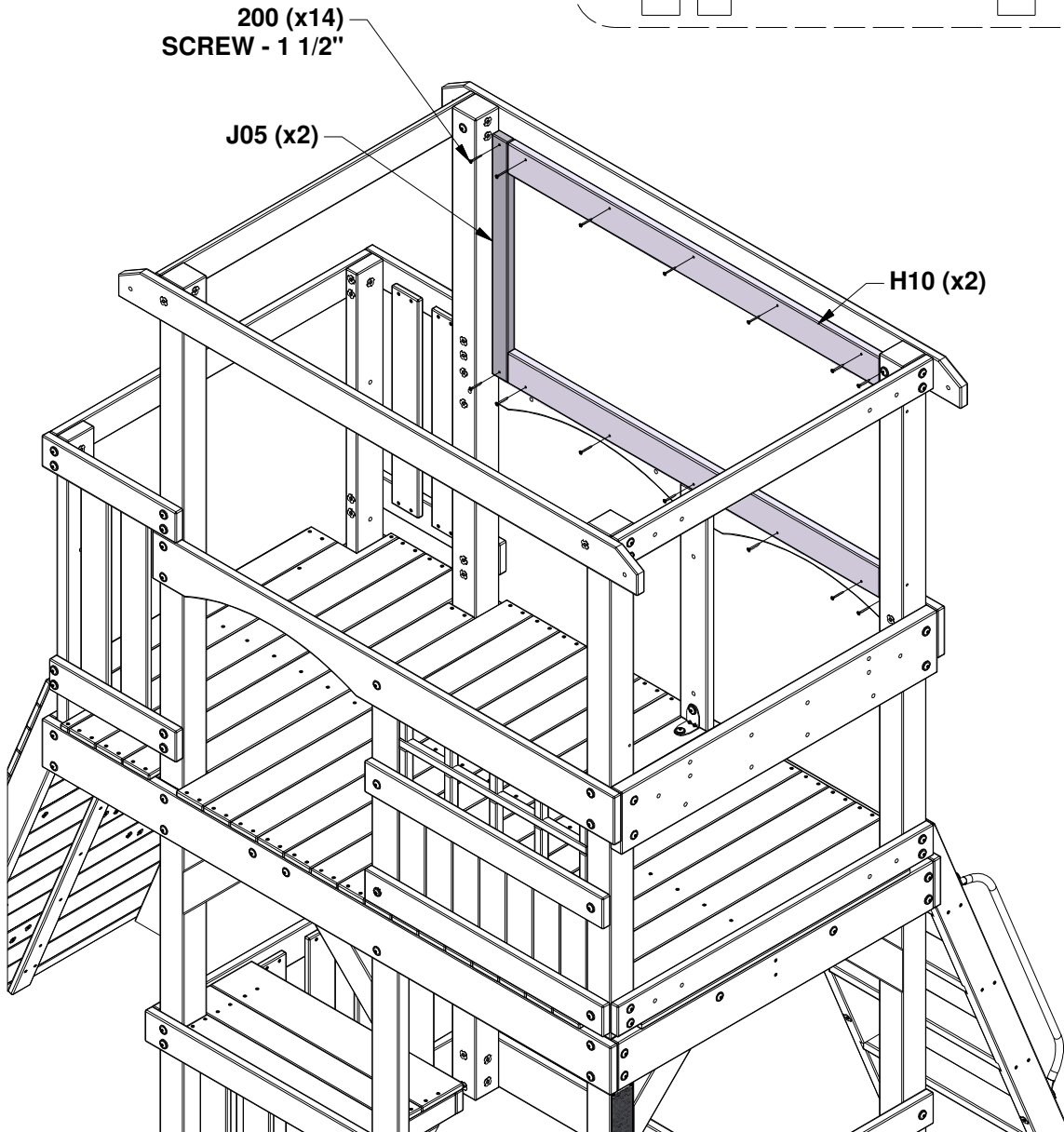
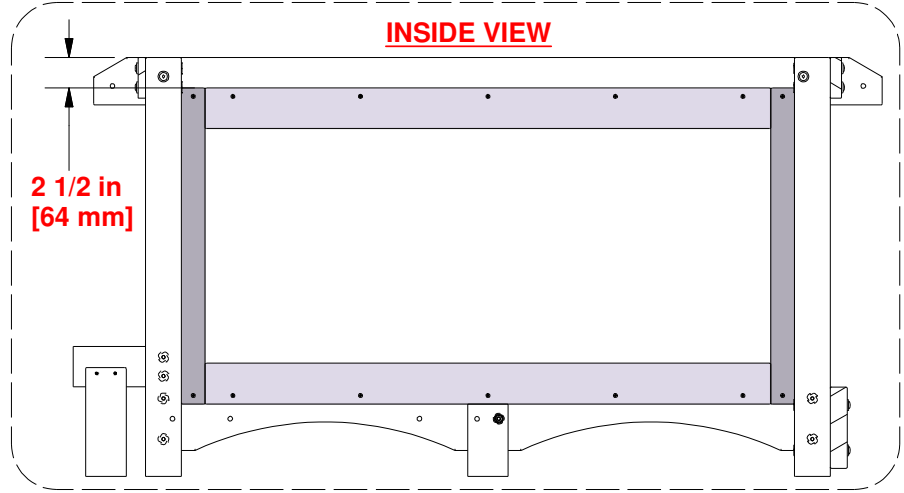

# STEP 34 - FORT ASSEMBLY

QTY	PART NUMBER	DESCRIPTION
14	H100200	SCREW PFH 8x1 1/2 BLK



**H10 WINDOW TRIM - W4L21392**  
 (x2) 1"x3 3/8"x47 1/8" (24x86x1198)



**J05 WINDOW TRIM - W4L21393**  
 (x2) 1"x2"x26 1/4" (24x50x668)

## INSIDE VIEW

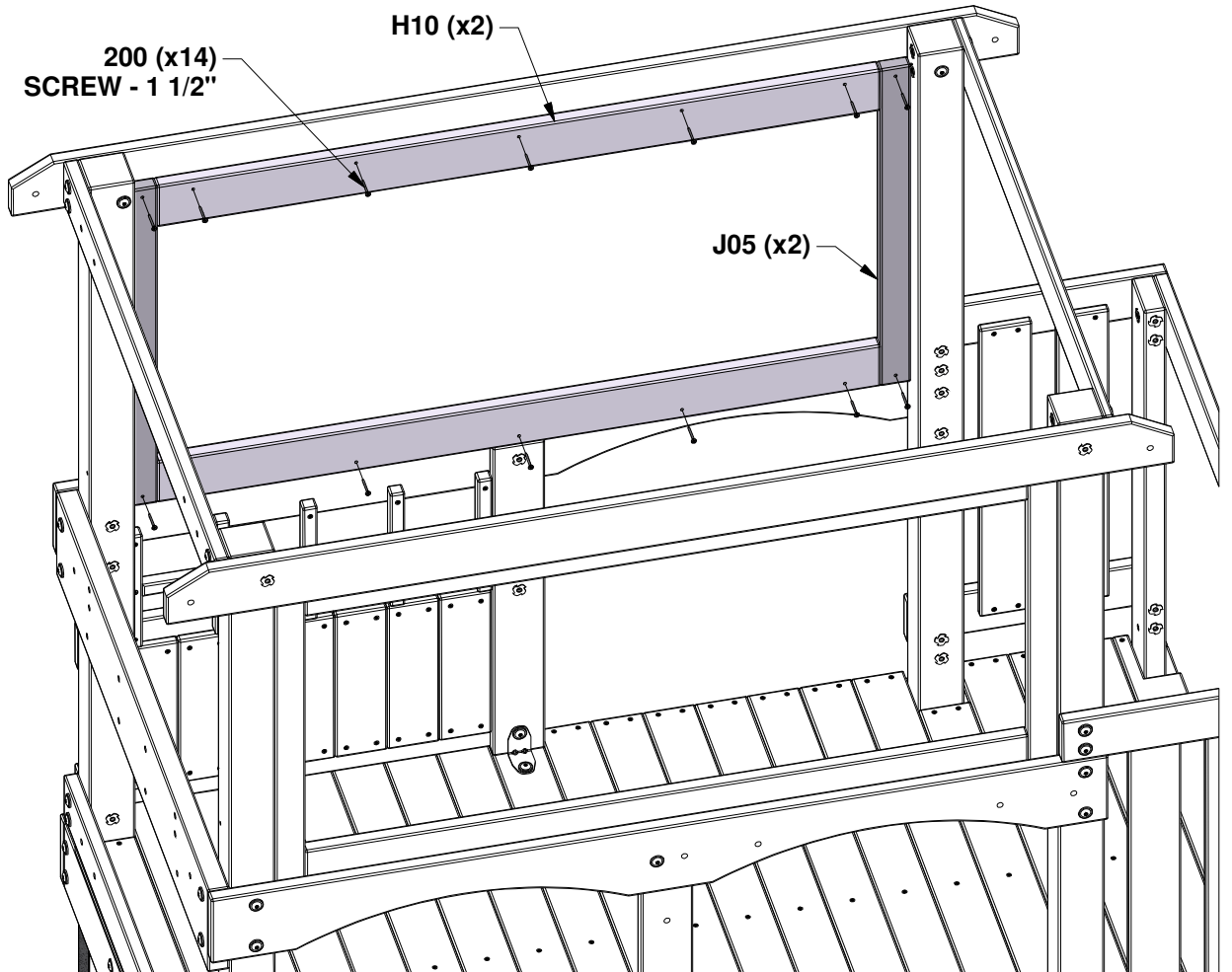
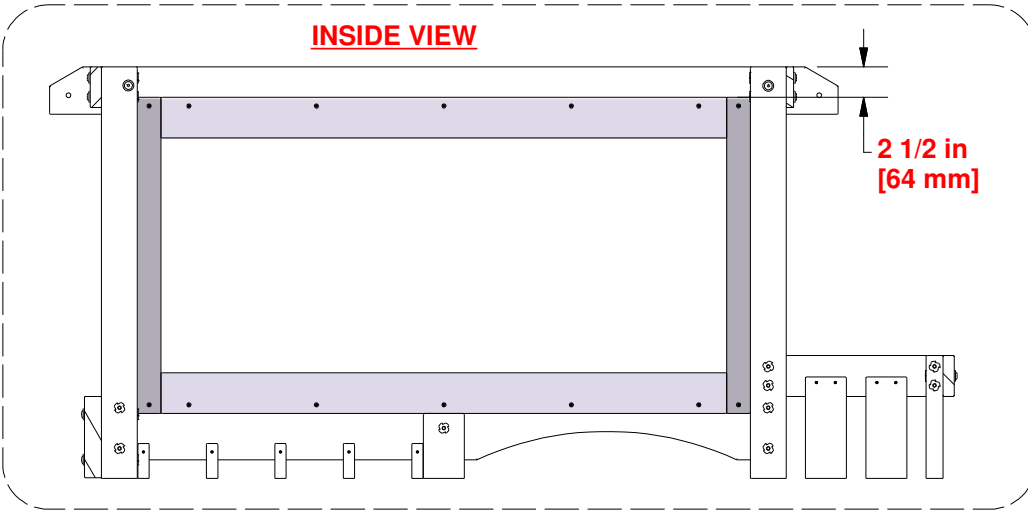

# STEP 35 - FORT ASSEMBLY

QTY	PART NUMBER	DESCRIPTION
16	H100200	SCREW PFH 8x1 1/2 BLK

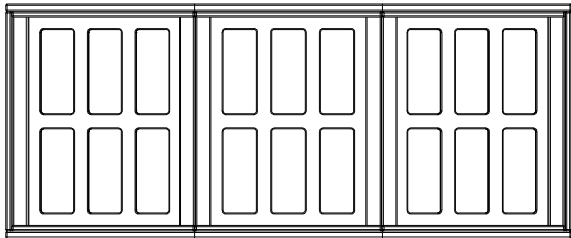

(x2) BAY WINDOW ASSEMBLY

## INSIDE VIEW

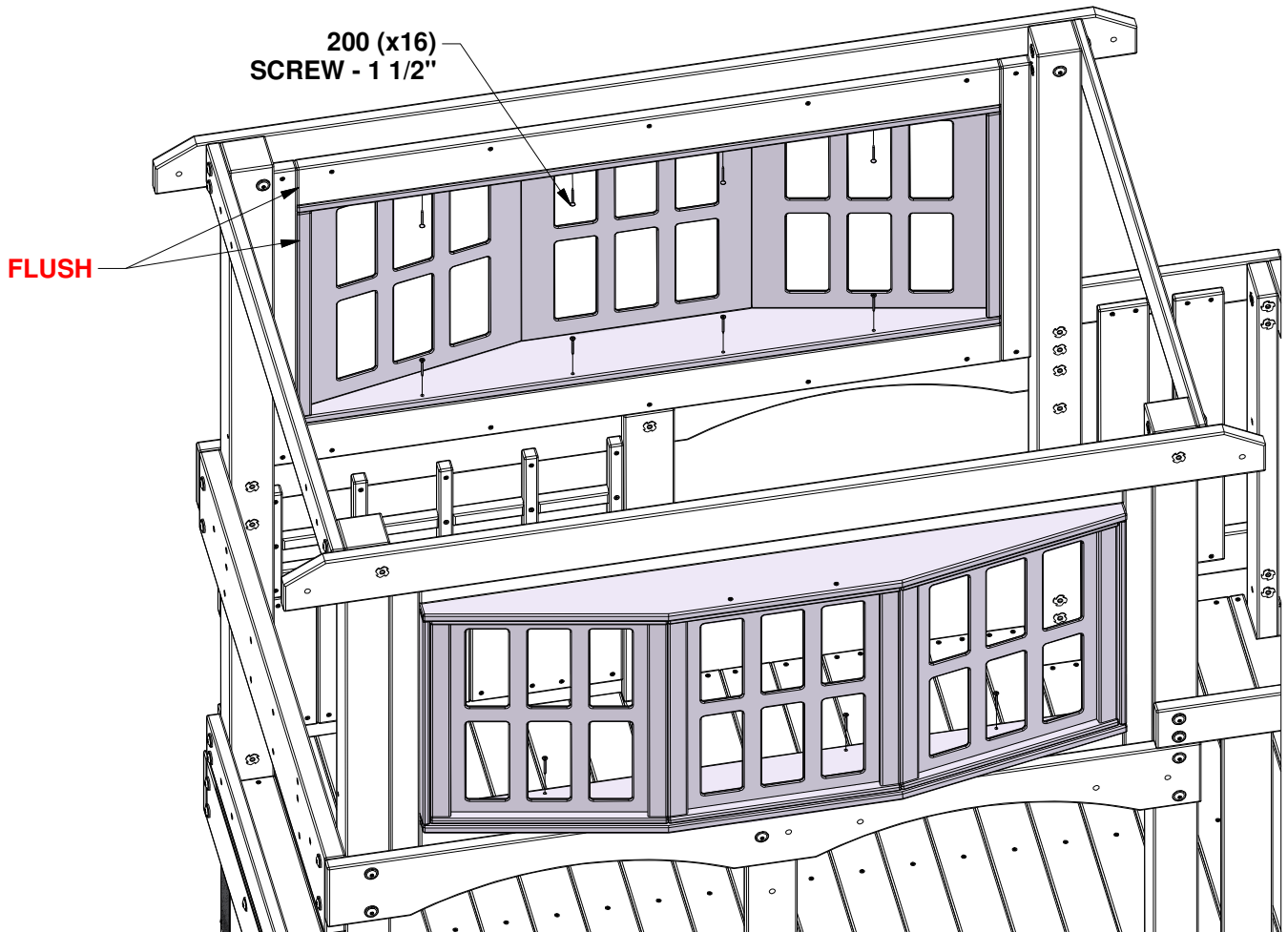
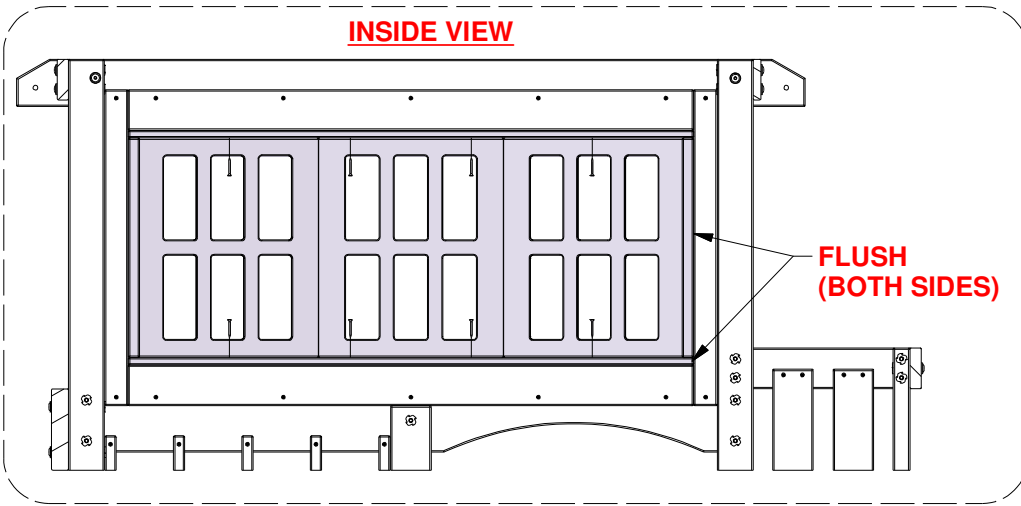

# STEP 36 - FORT ASSEMBLY

QTY	PART NUMBER	DESCRIPTION
2	H100195	BOLT WH 5/16x2 3/4 BLK
6	H100198	WASHER LOCK EXT 8x19 BLK
4	H100205	BOLT WH 5/16x2 1/4 BLK
14	H100379	T-NUT 5/16 BLK

E02 WALL BOARD - W4L21402  
(x2) 1 3/8"x3 3/8"x54 3/8" (36x86x1382)

## INSTALL T-NUTS IN WOOD FIRST

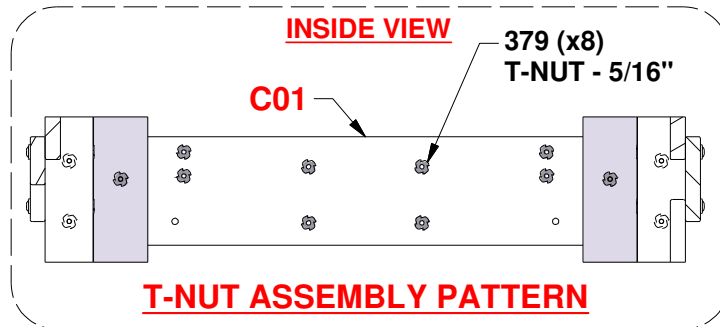
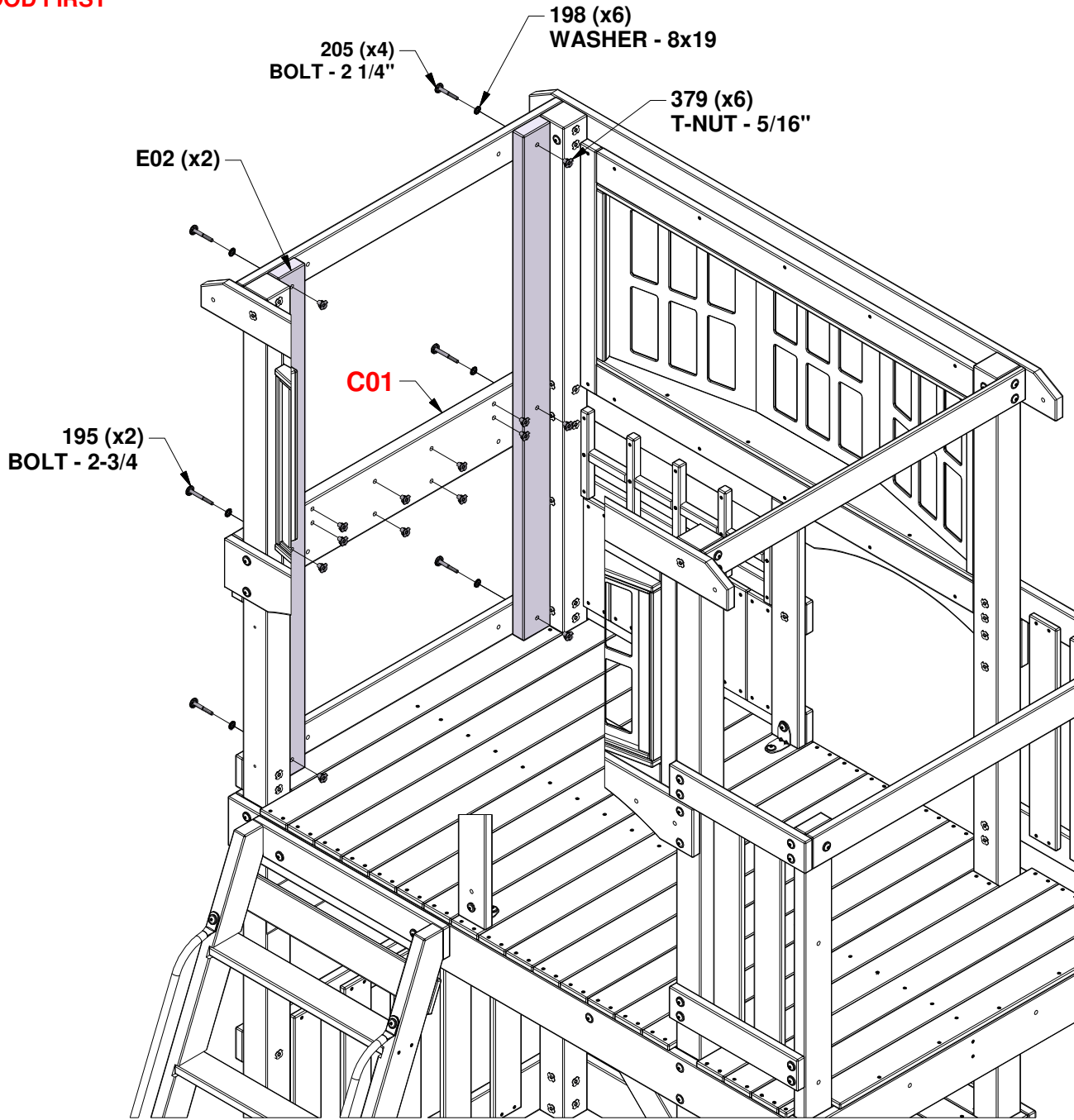

# STEP 37 - FORT ASSEMBLY

QTY	PART NUMBER	DESCRIPTION
4	H100378	BOLT WH 5/16x1 3/4 BLK
2	H100205	BOLT WH 5/16x2 1/4 BLK
6	H100198	WASHER LOCK EXT 8x19 BLK
6	H100379	T-NUT 5/16 BLK

H14 WALL BOARD - W4L21403  
(x2) 1"x3 3/8"x54 3/8" (24x86x1382)

## INSTALL T-NUTS IN WOOD FIRST

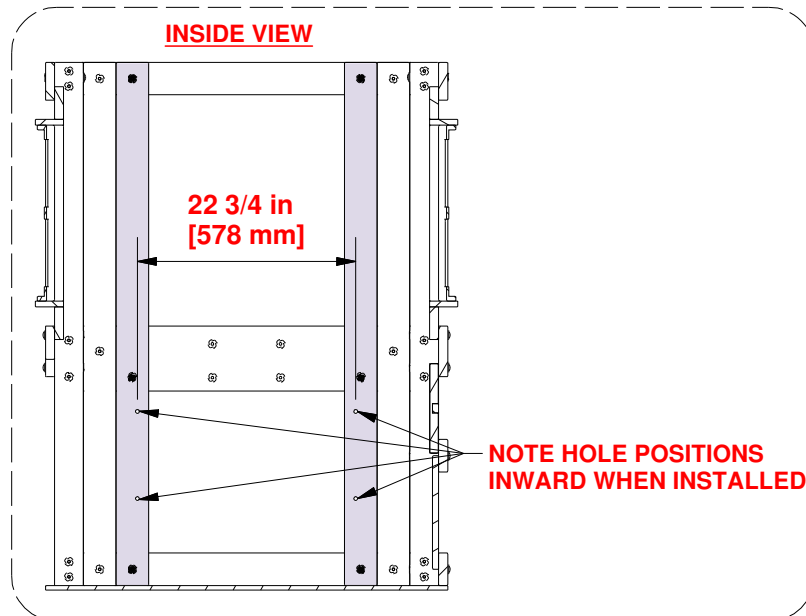
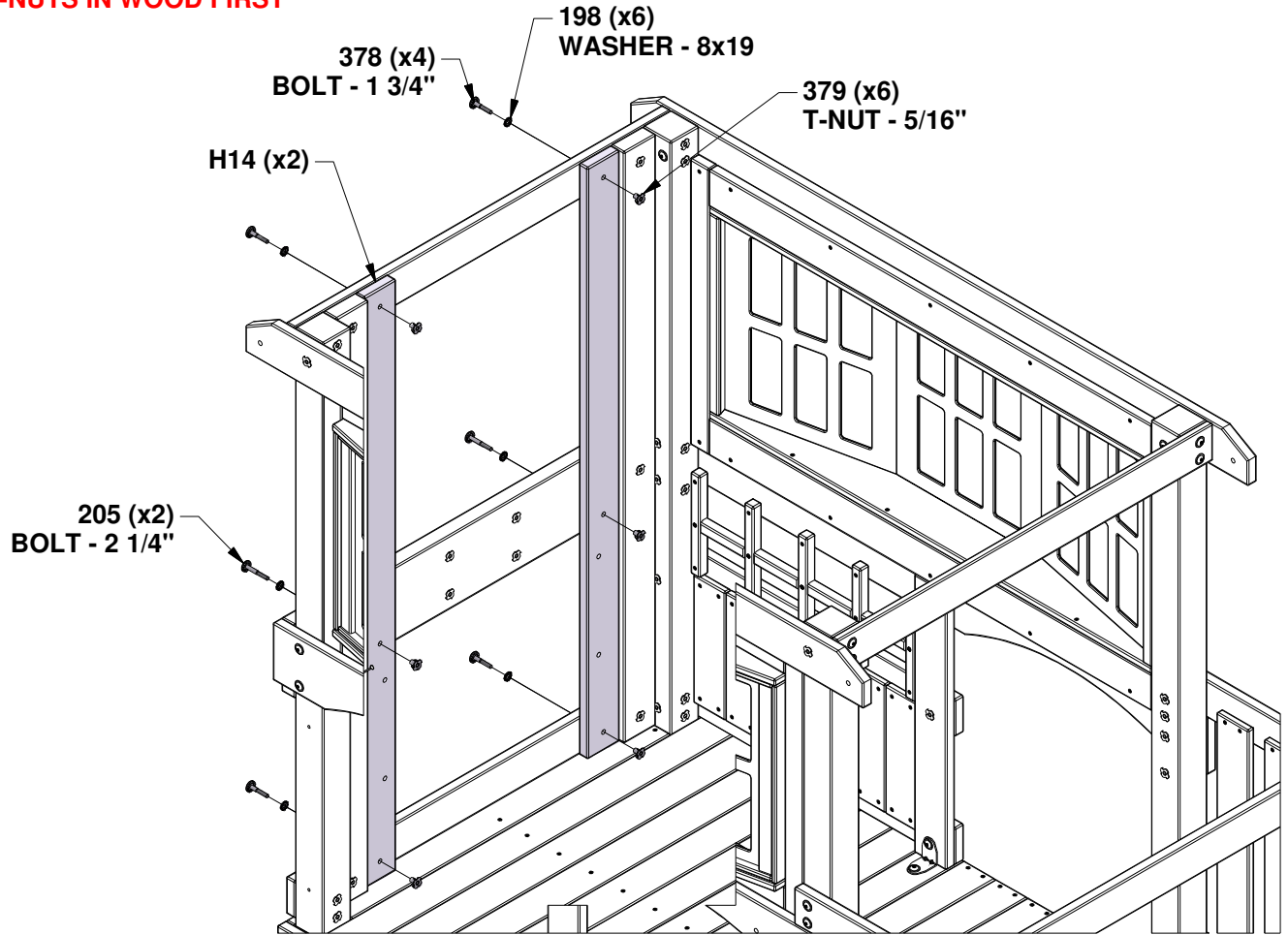

# STEP 38 - FORT ASSEMBLY

QTY	PART NUMBER	DESCRIPTION
24	H100387	SCREW PFH 8x1 1/4 BLK



M05 WALL BOARD - W4L21404  
(x6) 5/8"x3 3/8"x27" (16x86x686)

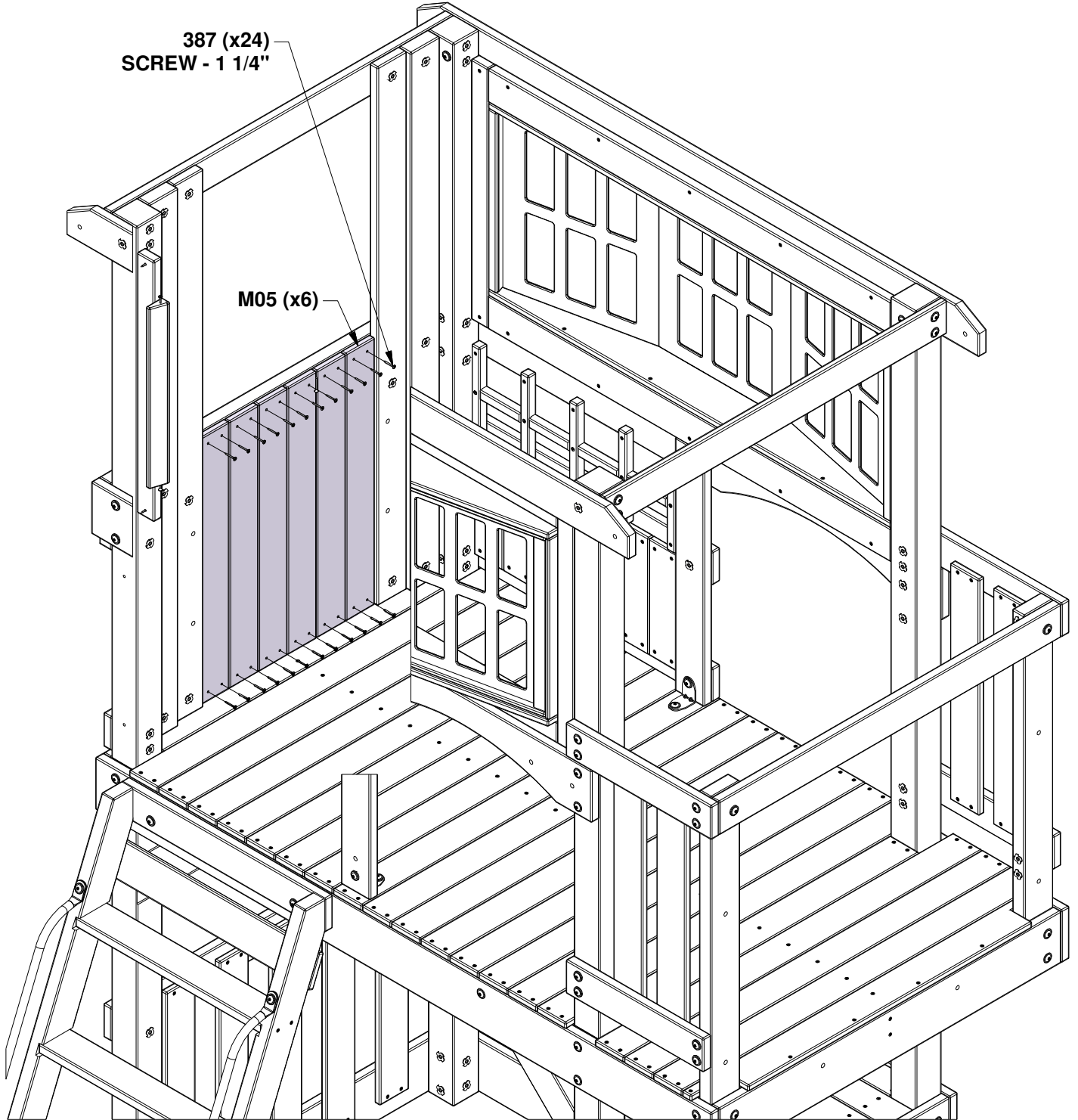

# STEP 39 - FORT ASSEMBLY

QTY	PART NUMBER	DESCRIPTION
4	H100498	BOLT HEX 5/16x1 1/2 BLK
4	H100477	WASHER SPLIT 5/16 BLK
4	H100478	WASHER FLAT 8x27

(x1) SWING BEAM ASSEMBLY

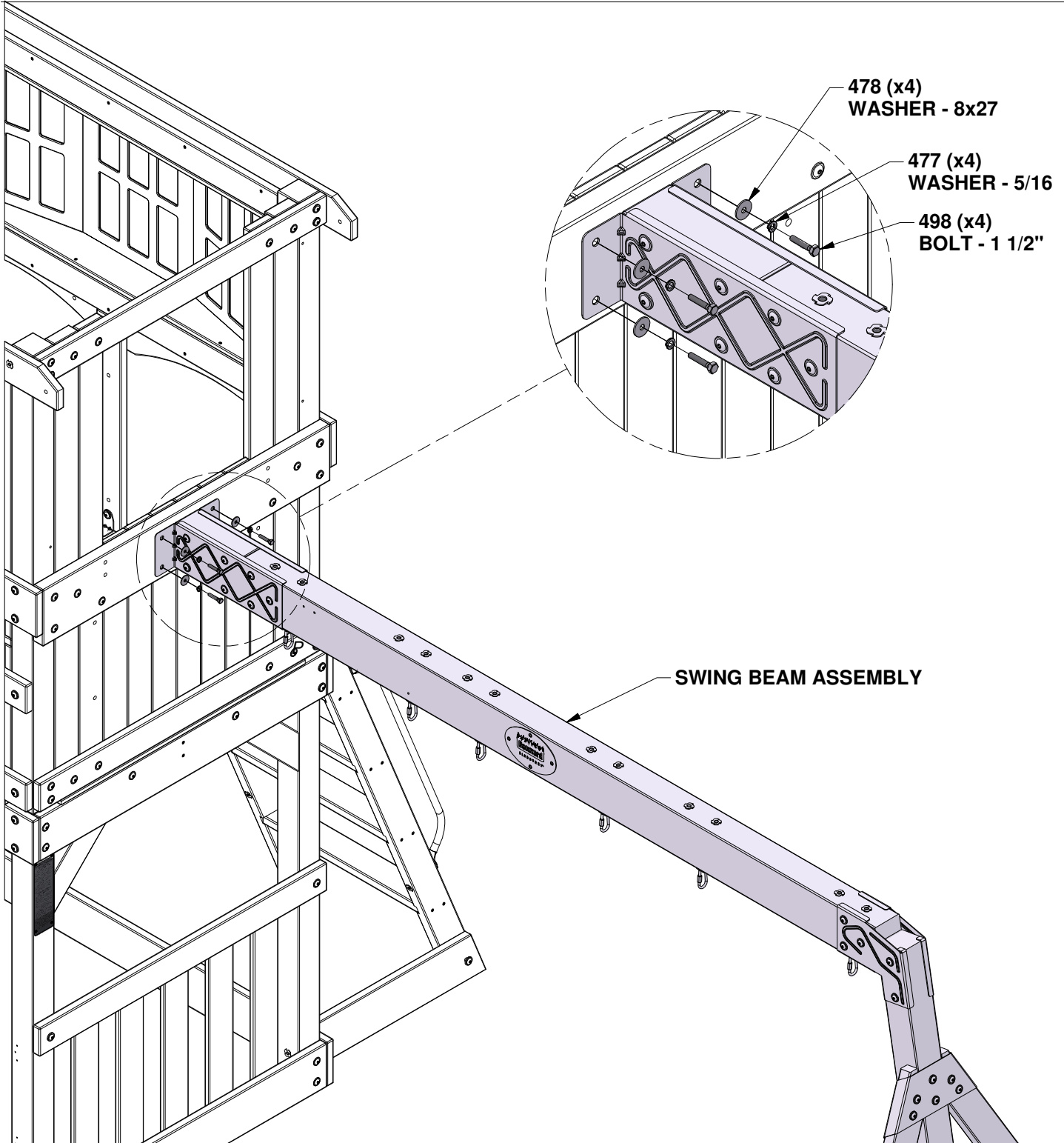
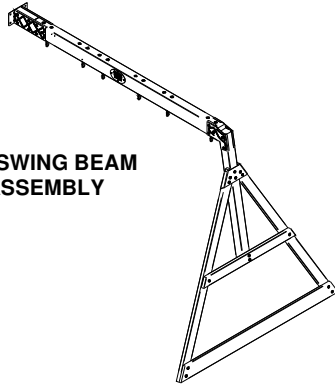

# STEP 40 - FORT ASSEMBLY

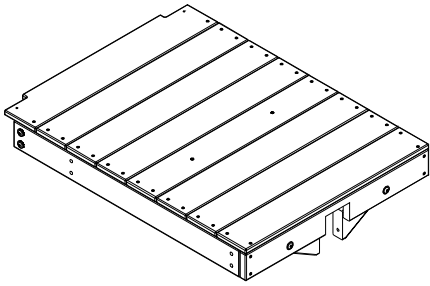

(x1) CROWS NEST DECK ASSEMBLY

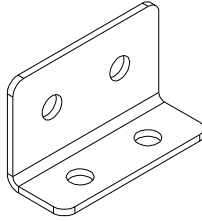

A4M00855 (x2) L BRACKET 51x32x82x3.175

QTY	PART NUMBER	DESCRIPTION
4	H100192	NUT BARREL WH 7/8 BLK
4	H100199	WASHER LOCK EXT 12x19 BLK
2	H100200	SCREW PFH 8x1 1/2 BLK
2	H100405	WASHER LOCK EXT 6x15 BLK
2	H100456	LAG SCREW 1/4x2 1/2 BLK
8	H100477	WASHER SPLIT 5/16 BLK
8	H100478	WASHER FLAT 8x27 BLK
4	H100481	BOLT HEX 5/16x1 1/4 BLK
4	H100657	BOLT HEX 5/16x1-3/4 BLK

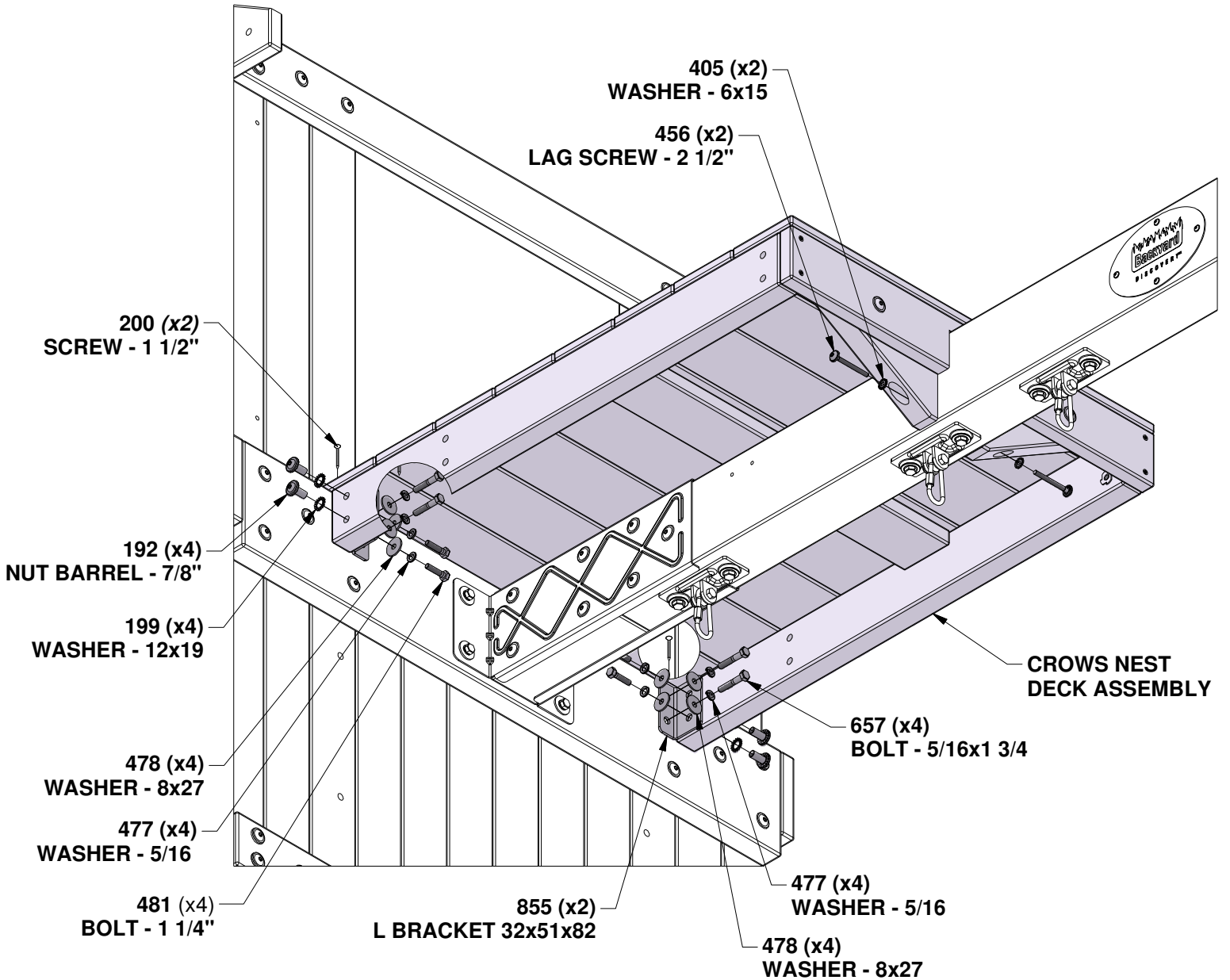

# STEP 41 - FORT ASSEMBLY

QTY	PART NUMBER	DESCRIPTION
8	H100659	LAG SCREW HEX 5/16x1 1/2 BLK
8	H100477	WASHER SPLIT 5/16 BLK
8	H100478	WASHER FLAT 8x27 BLK

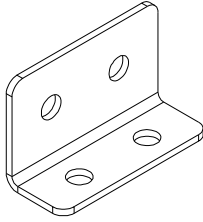

**A4M00855**  
(x2) **L BRACKET 51x32x82x3.175**

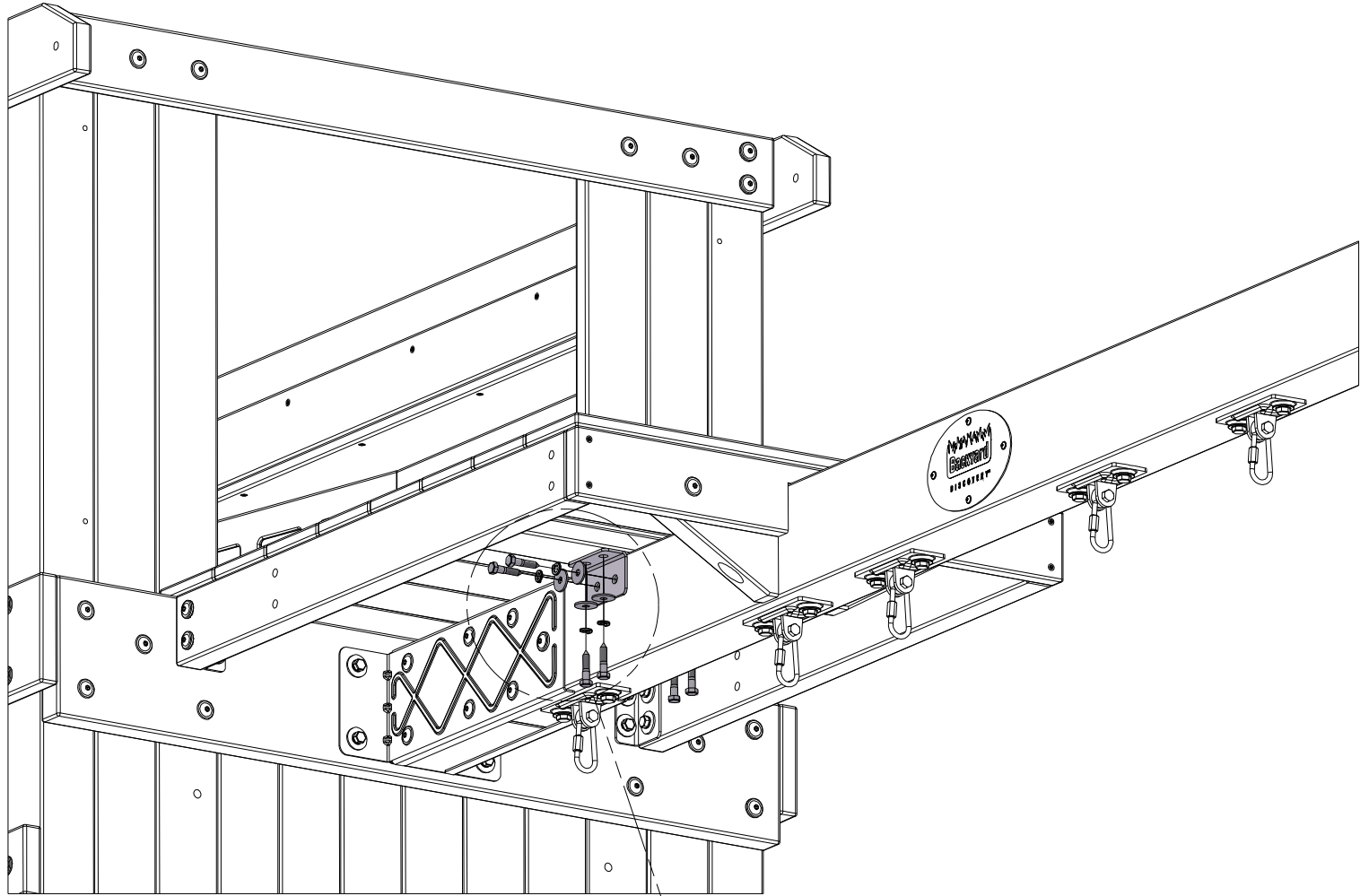

**NOTE:**  
**USING BRACKET AS A GUIDE,**  
**DRILL 3/16" (5 mm) X 1" DEEP**  
**PILOT HOLES. 2 PLACES**  
**EACH SIDE.**

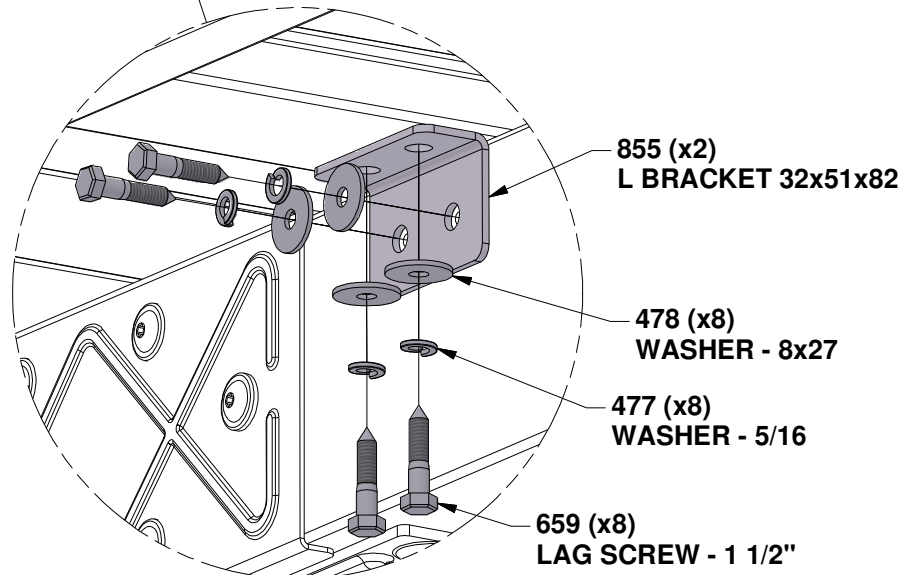

# STEP 42 - FORT ASSEMBLY

QTY	PART NUMBER	DESCRIPTION
8	H100195	BOLT WH 5/16x2 3/4 BLK
8	H100198	WASHER LOCK EXT 8x19 BLK
4	H100379	T-NUT 5/16 BLK



**F01 CROWS NEST WALL SUPPORT - W4L21405**  
 (x2) 1 3/8"x2 3/8"x37 1/2" (36x60x952)



**F02 CROWS NEST WALL SUPPORT - W4L21406**  
 (x2) 1 3/8"x2 3/8"x37 1/2" (36x60x952)

## INSTALL T-NUTS IN WOOD FIRST

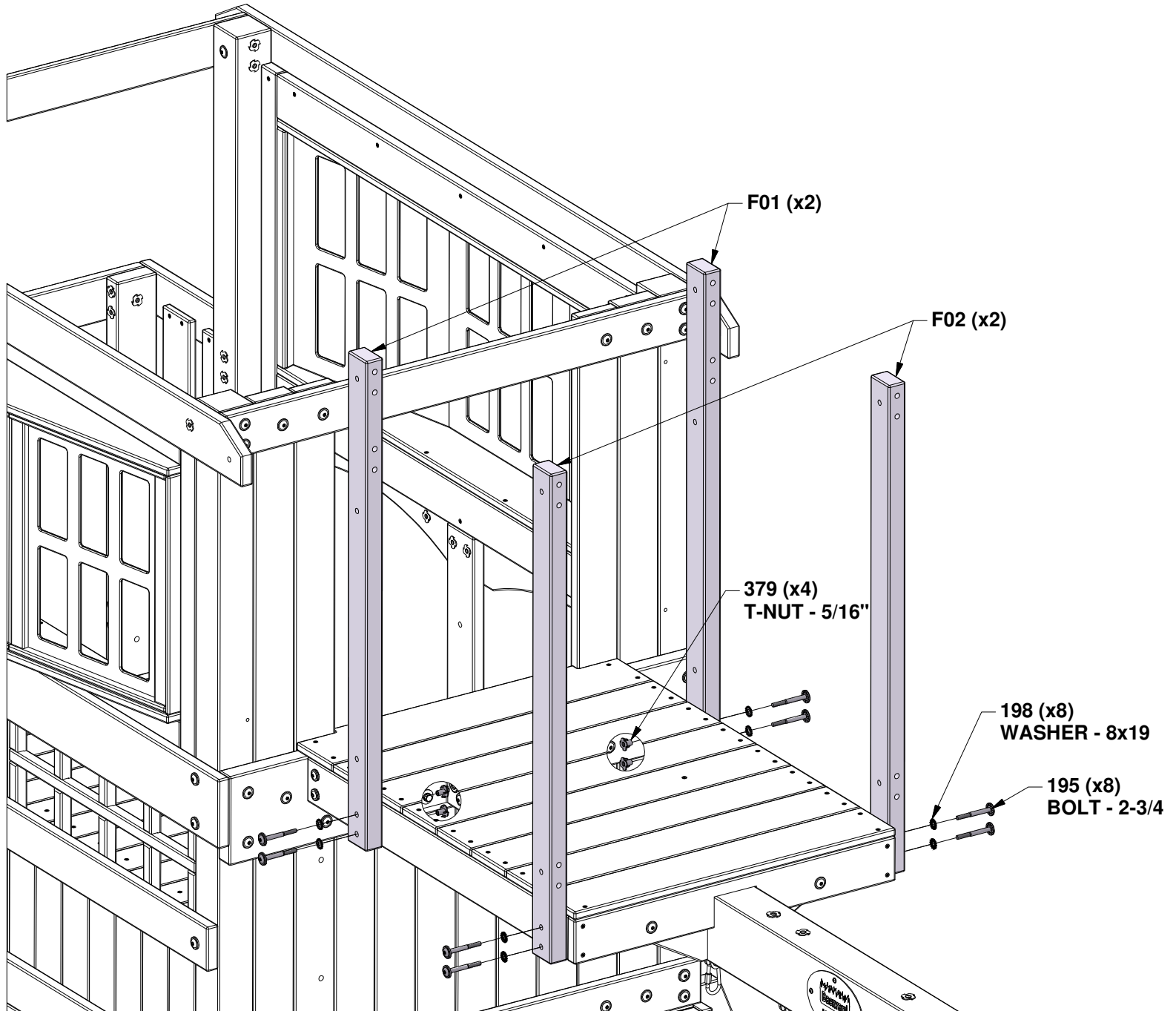

# STEP 43 - FORT ASSEMBLY

QTY	PART NUMBER	DESCRIPTION
4	H100205	BOLT WH 5/16x2 1/4 BLK
4	H100484	BOLT WH 5/16x3 1/4 BLK
8	H100198	WASHER LOCK EXT 8x19 BLK
8	H100379	T-NUT 5/16 BLK



**H21 CROWS NEST WALL RAIL - W4L21408**  
(x1) 1"x3 3/8"x29 7/8" (24x86x758)



**H22 CROWS NEST WALL RAIL - W4L21409**  
(x2) 1"x3 3/8"x34 3/4" (24x86x882)

## INSTALL T-NUTS IN WOOD FIRST

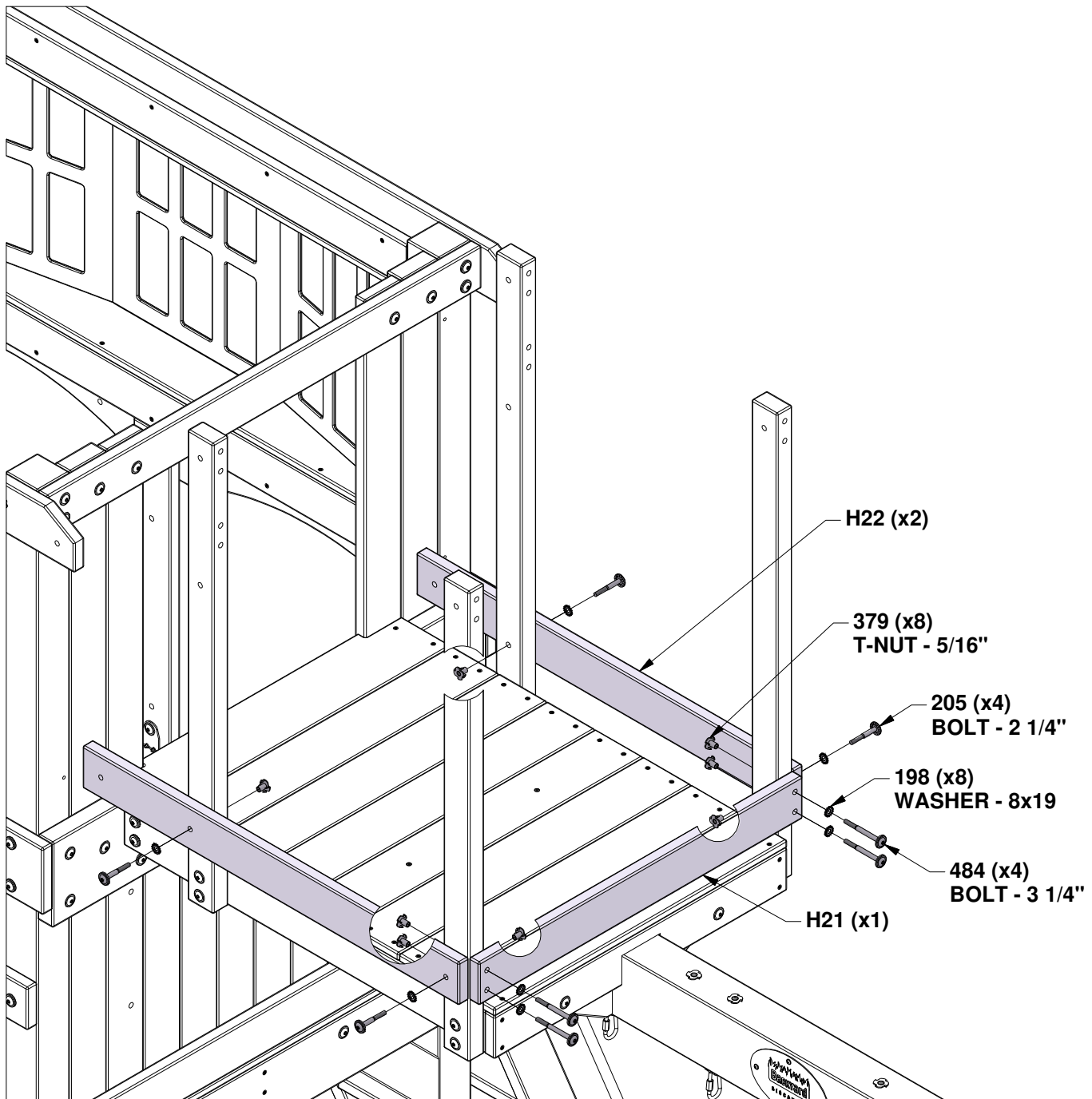

# STEP 44 - FORT ASSEMBLY

QTY	PART NUMBER	DESCRIPTION
2	H100468	BOLT WH 5/16x1 BLK
2	H100471	LAG SCREW WH 5/16x1 1/2 BLK
2	H100379	T-NUT 5/16 BLK

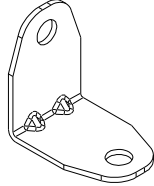

**A4M01047**  
(x2) **L BRACKET 2.5x38x55x55**

**INSTALL T-NUTS IN WOOD FIRST**

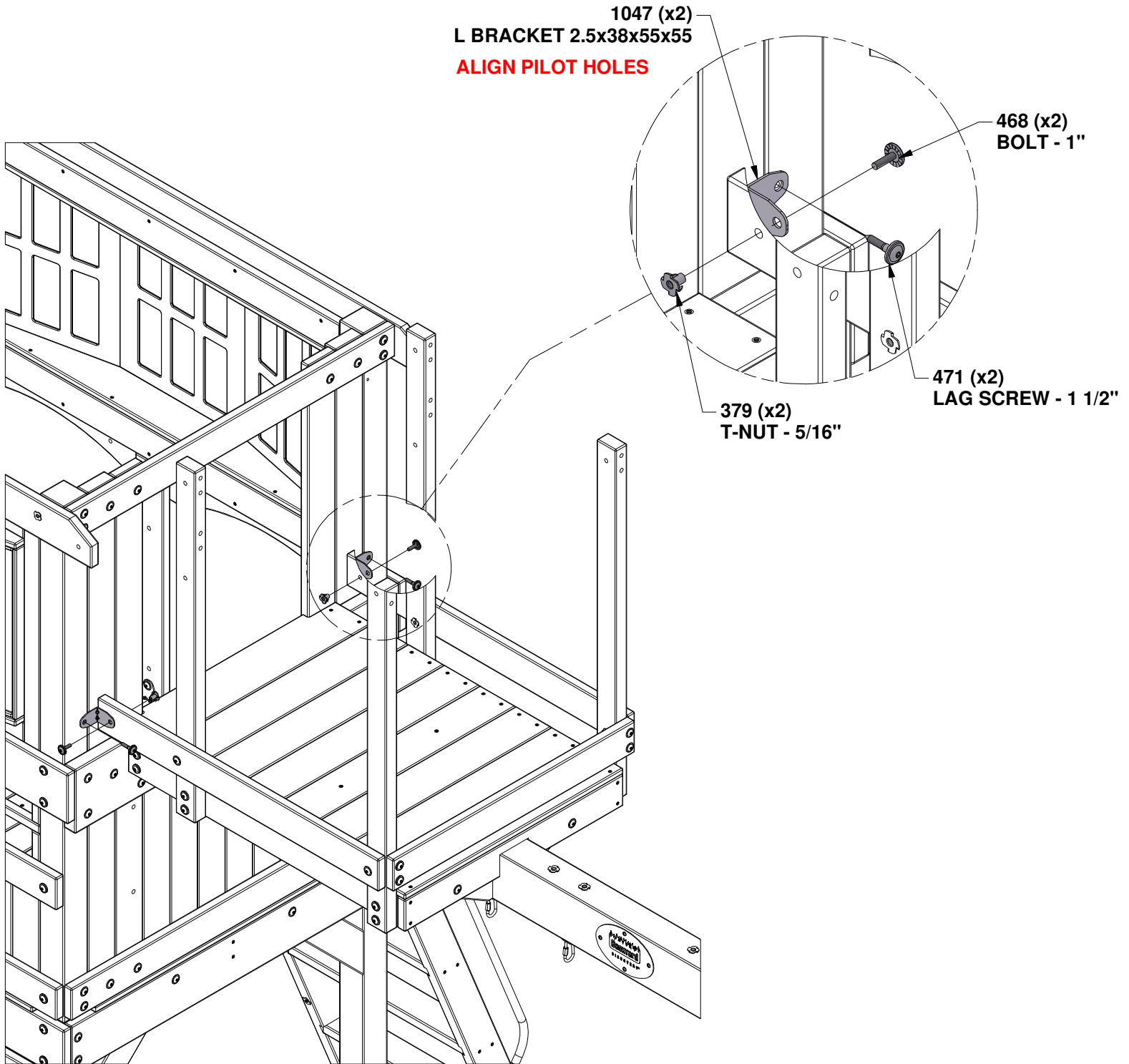

# STEP 45 - FORT ASSEMBLY

QTY	PART NUMBER	DESCRIPTION
16	H100198	WASHER LOCK EXT 8x19 BLK
4	H100205	BOLT WH 5/16x2 1/4 BLK
16	H100379	T-NUT 5/16 BLK
8	H100416	BOLT WH 5/16x3 BLK
4	H100484	BOLT WH 5/16x3 1/4 BLK



**H21 CROWS NEST WALL RAIL - W4L21408**  
(x1) 1"x3 3/8"x29 7/8" (24x86x758)



**H23 CROWS NEST WALL RAIL - W4L21411**  
(x2) 1"x3 3/8"x26" (24x86x660)



**M06 CROWS NEST WALL RAIL - W4L21410**  
(x2) 5/8"x3 3/8"x29 7/8" (16x86x758)

## INSTALL T-NUTS IN WOOD FIRST

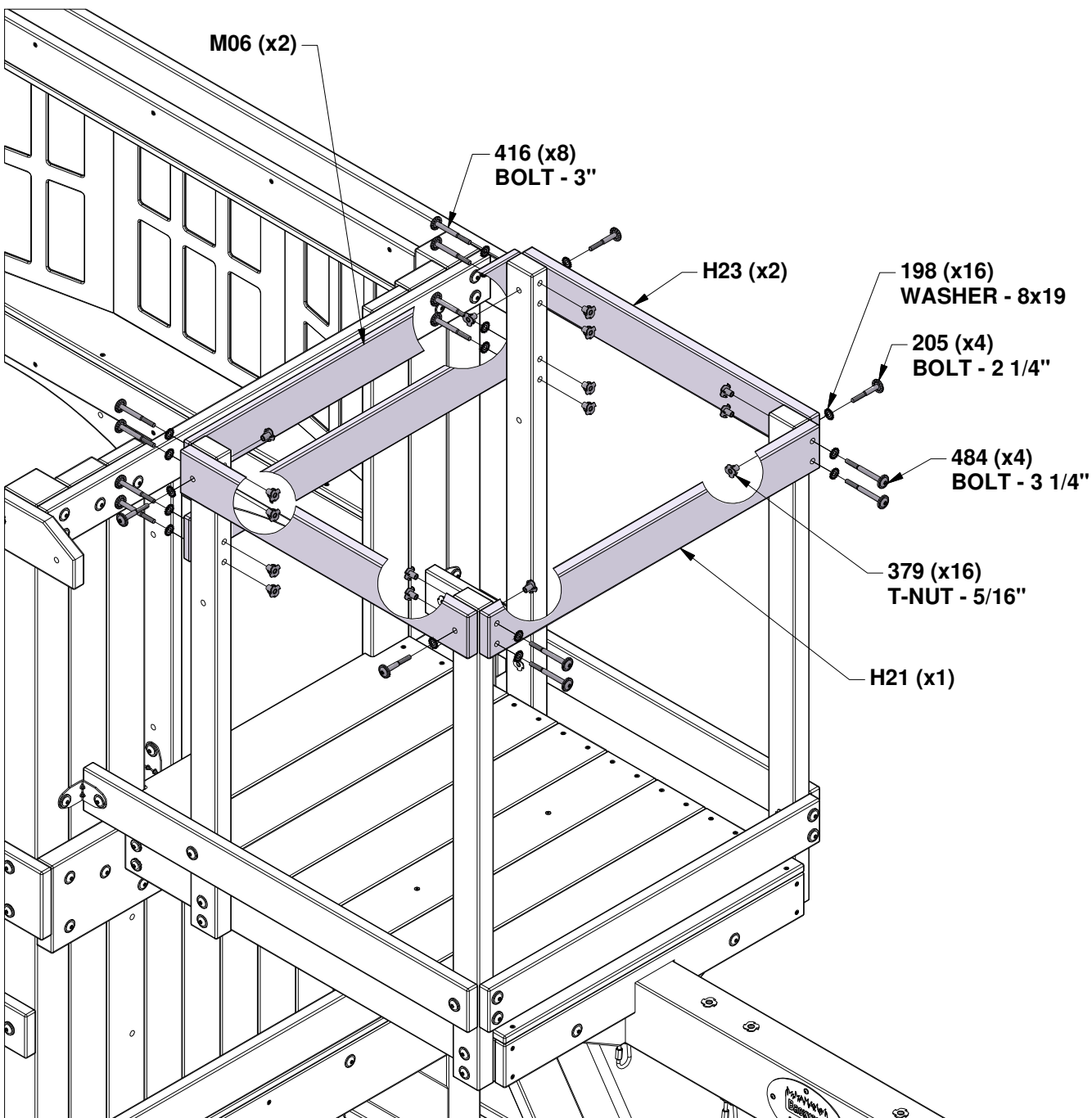

# STEP 46 - FORT ASSEMBLY

QTY	PART NUMBER	DESCRIPTION
2	H100198	WASHER LOCK EXT 8x19 BLK
2	H100205	BOLT WH 5/16x2 1/4 BLK
4	H100379	T-NUT 5/16 BLK
2	H100468	BOLT WH 5/16x1 BLK
2	H100471	LAG SCREW WH 5/16x1 1/2 BLK

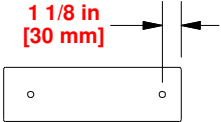

H24 CROWS NEST WALL RAIL - W4L21412  
(x2) 1"x3 3/8"x11 1/8" (24x86x282)

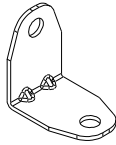

A4M01047  
(x2) L BRACKET 2.5x38x55x55

## INSTALL T-NUTS IN WOOD FIRST

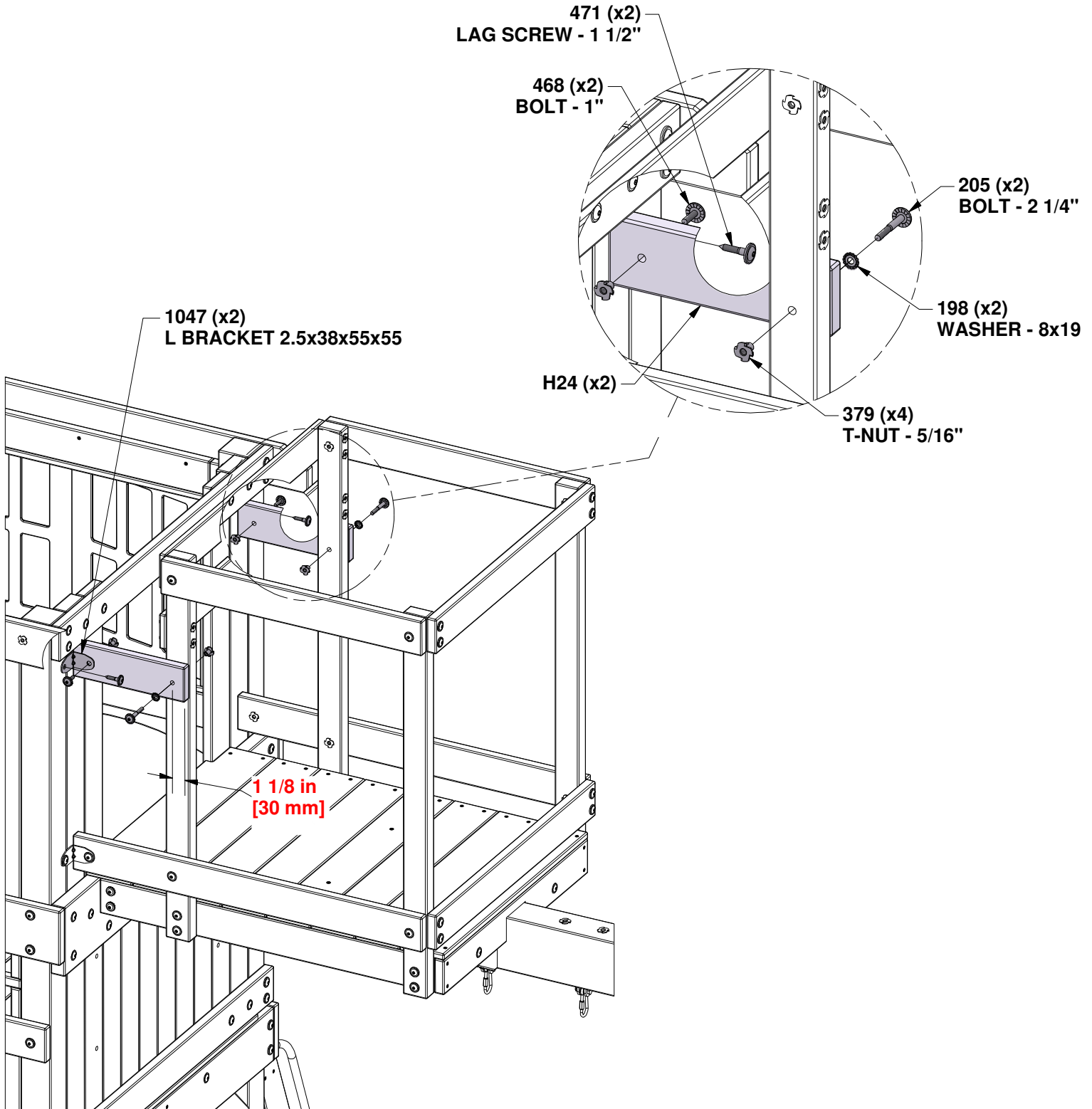

# STEP 47 - FORT ASSEMBLY

QTY	PART NUMBER	DESCRIPTION
4	H100387	SCREW PFH 8x1 1/4 BLK



**N02 CROWS NEST WALL BOARD - W4L21414**  
(x2) 5/8"x2 3/8"x22 3/8" (16x60x568)

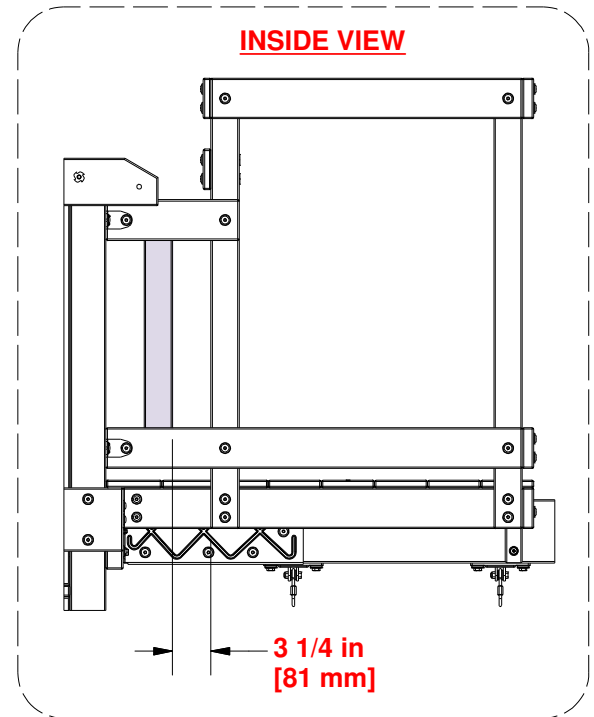
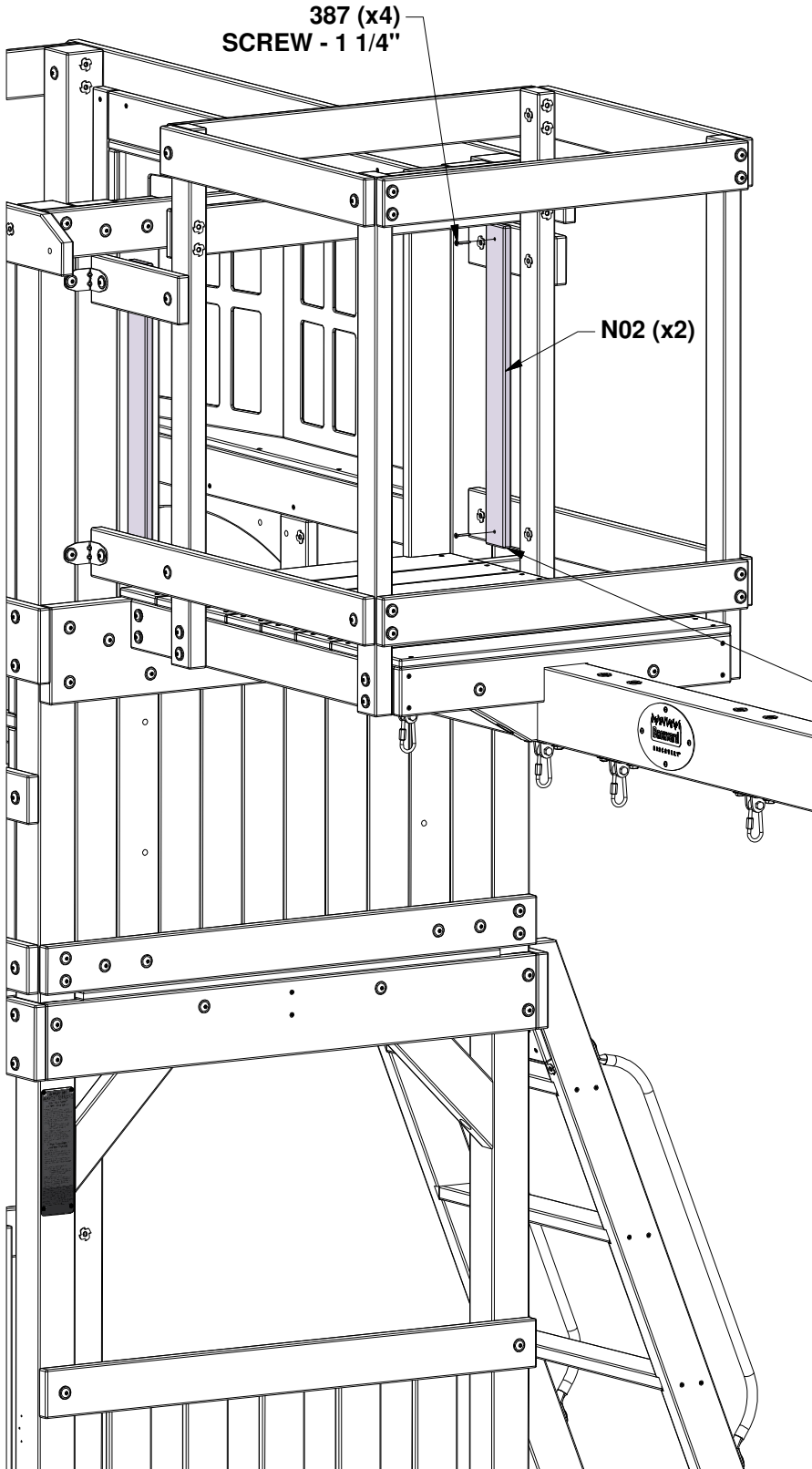

**FLUSH BOTTOMS**

# STEP 48 - FORT ASSEMBLY

QTY	PART NUMBER	DESCRIPTION
12	H100387	SCREW PFH 8x1 1/4 BLK

001 CROWS NEST WALL BOARD - W4L21413  
(x6) 5/8"x1 3/8"x32 1/4" (16x34x819)

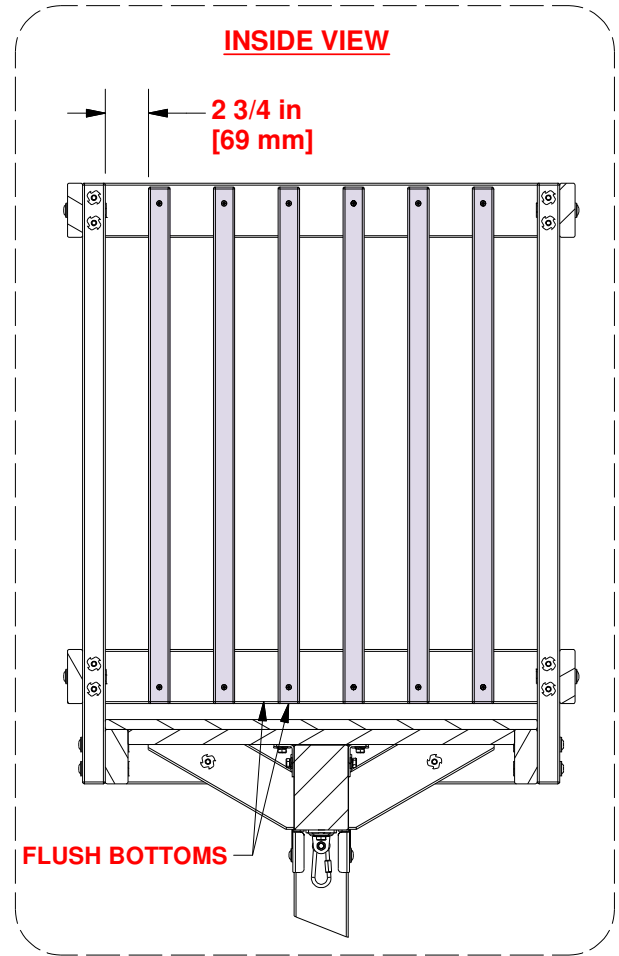
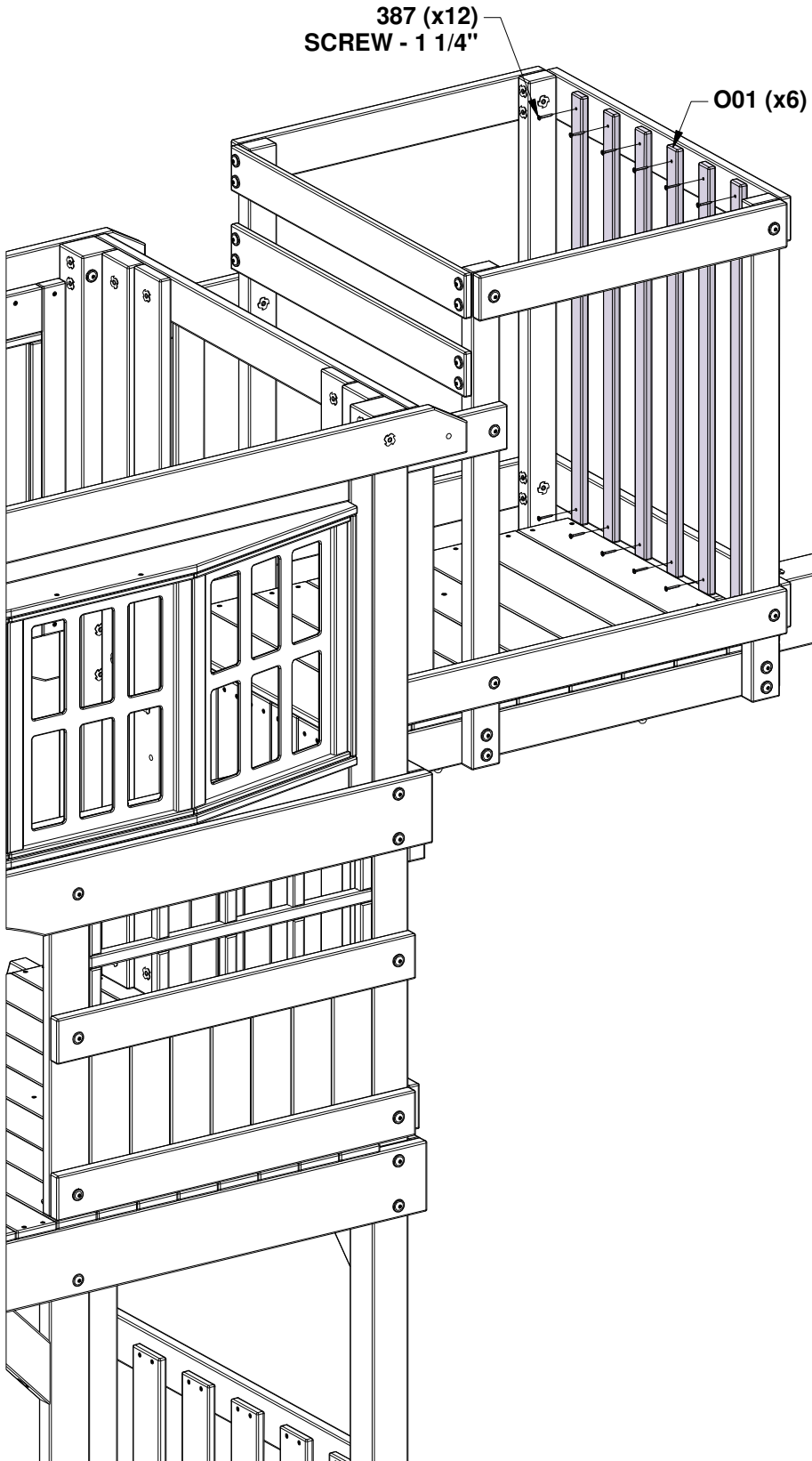

# STEP 49 - FORT ASSEMBLY

QTY	PART NUMBER	DESCRIPTION
20	H100387	SCREW PFH 8x1-1/4 BLK

O01 CROWS NEST WALL BOARD - W4L21413  
(x10) 5/8"x1 3/8"x32 1/4" (16x34x819)

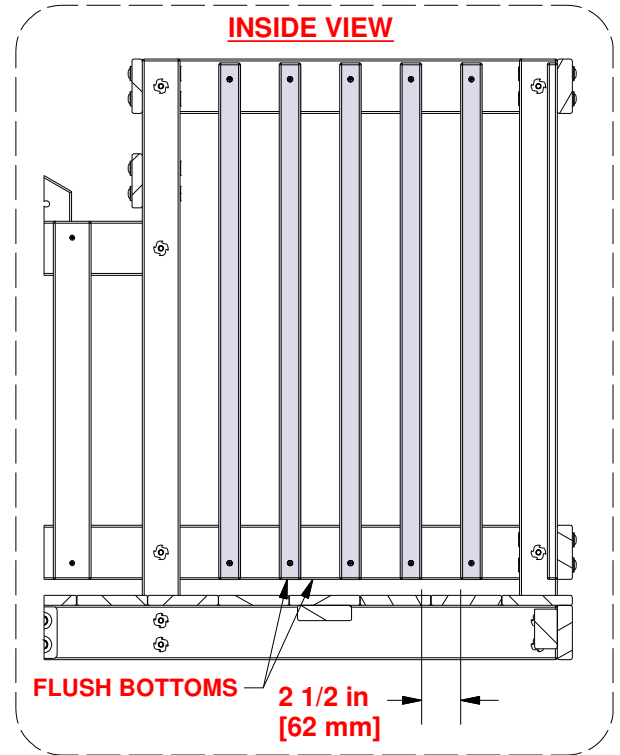
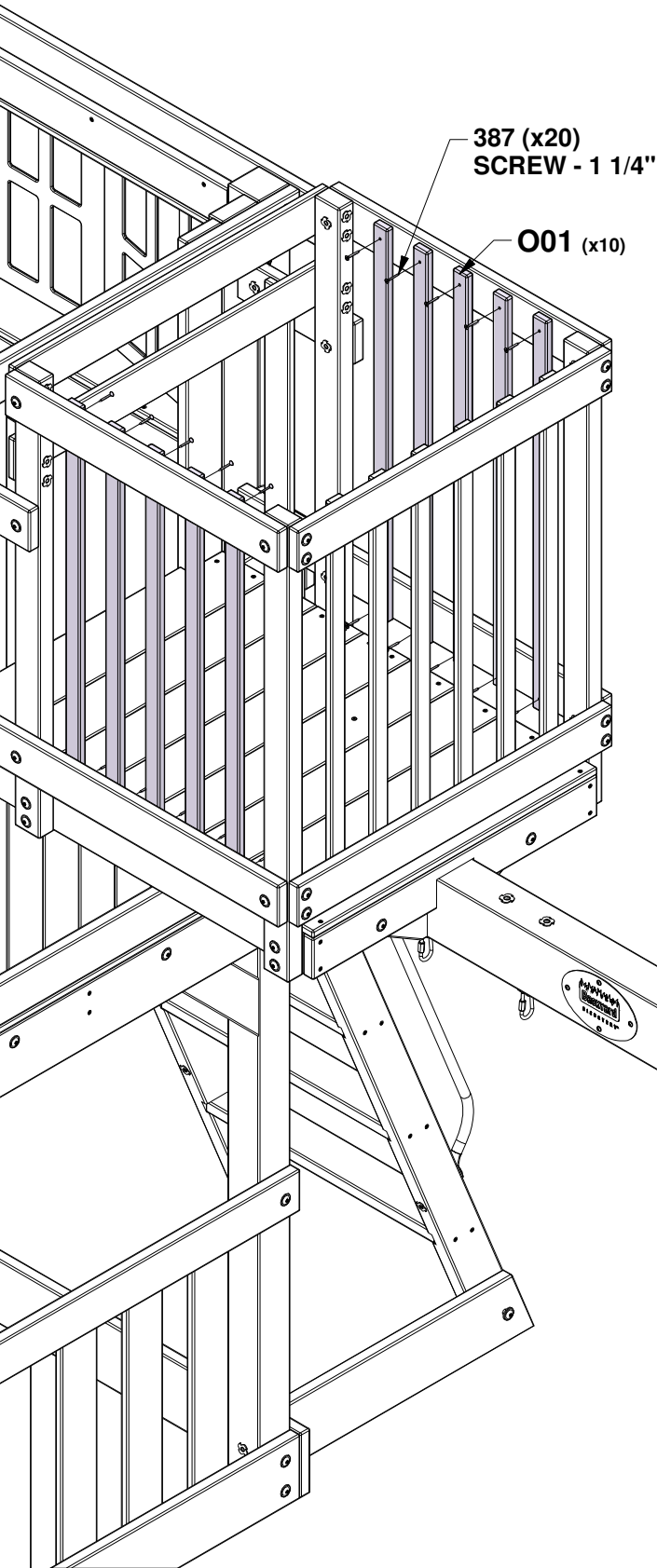

# STEP 50 - FORT ASSEMBLY

QTY	PART NUMBER	DESCRIPTION
16	H100797	SCREW PWH 8x1 BLK

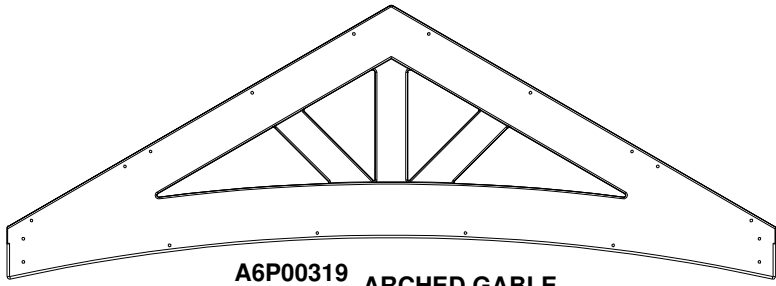

**A6P00319**  
*(x2)* **ARCHED GABLE**

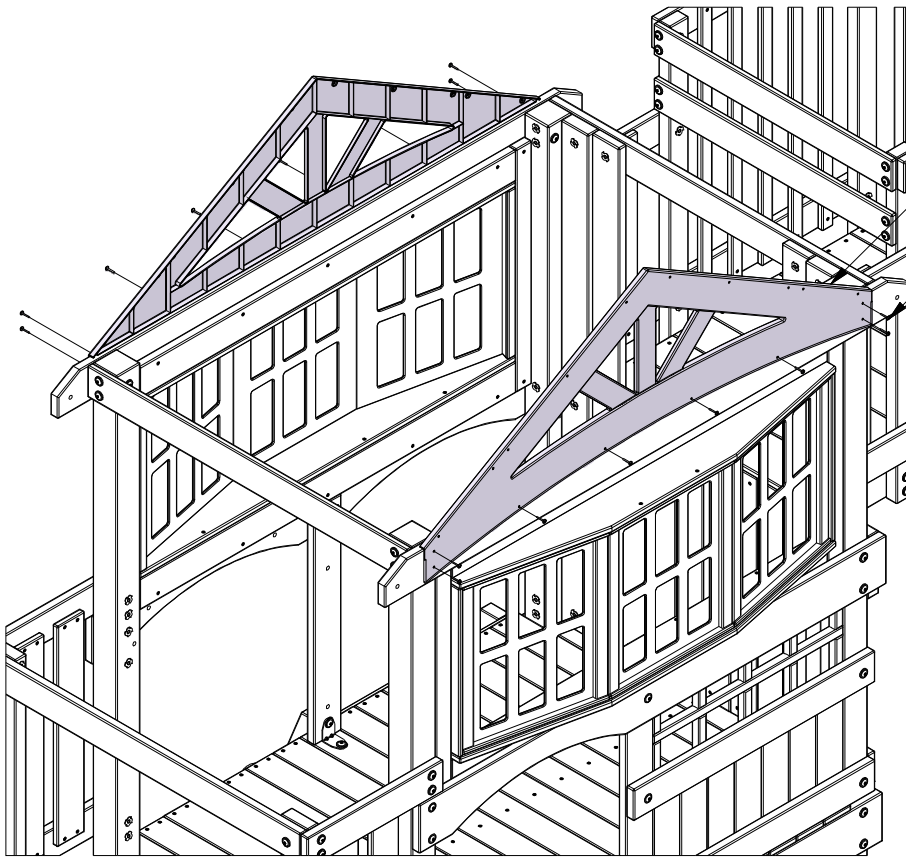

**319 (x2)**  
**ARCHED GABLE**

**797 (x16)**  
**SCREW - 1"**

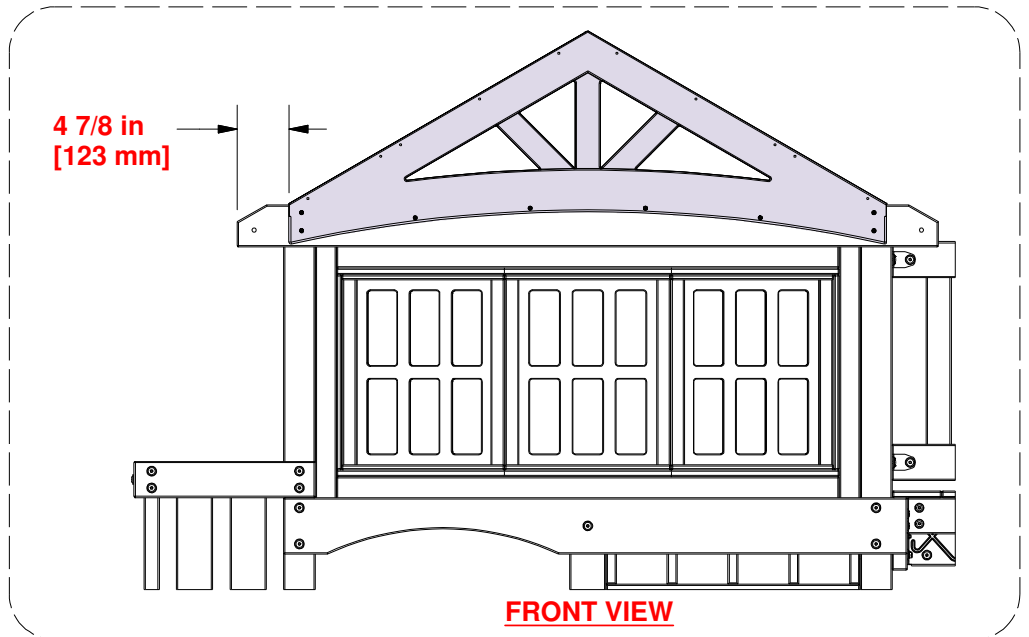

**4 7/8 in**  
**[123 mm]**

**FRONT VIEW**

# STEP 51 - FORT ASSEMBLY

QTY	PART NUMBER	DESCRIPTION
4	H100192	NUT BARREL WH 5/16x7/8 BLK
4	H100198	WASHER LOCK EXT 8x19 BLK
4	H100199	WASHER LOCK EXT 12x19 BLK
4	H100378	BOLT WH 5/16x1 3/4 BLK
20	H100797	SCREW PWH 8x1 BLK



**H27 LEFT ROOF RAFTER - W4L21415**  
(x2) 1"x3 3/8"x42 1/8" (24x86x1069)

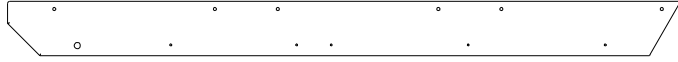

**H28 RIGHT ROOF RAFTER - W4L21416**  
(x2) 1"x3 3/8"x42 1/8" (24x86x1069)

## ALIGN PILOT HOLES

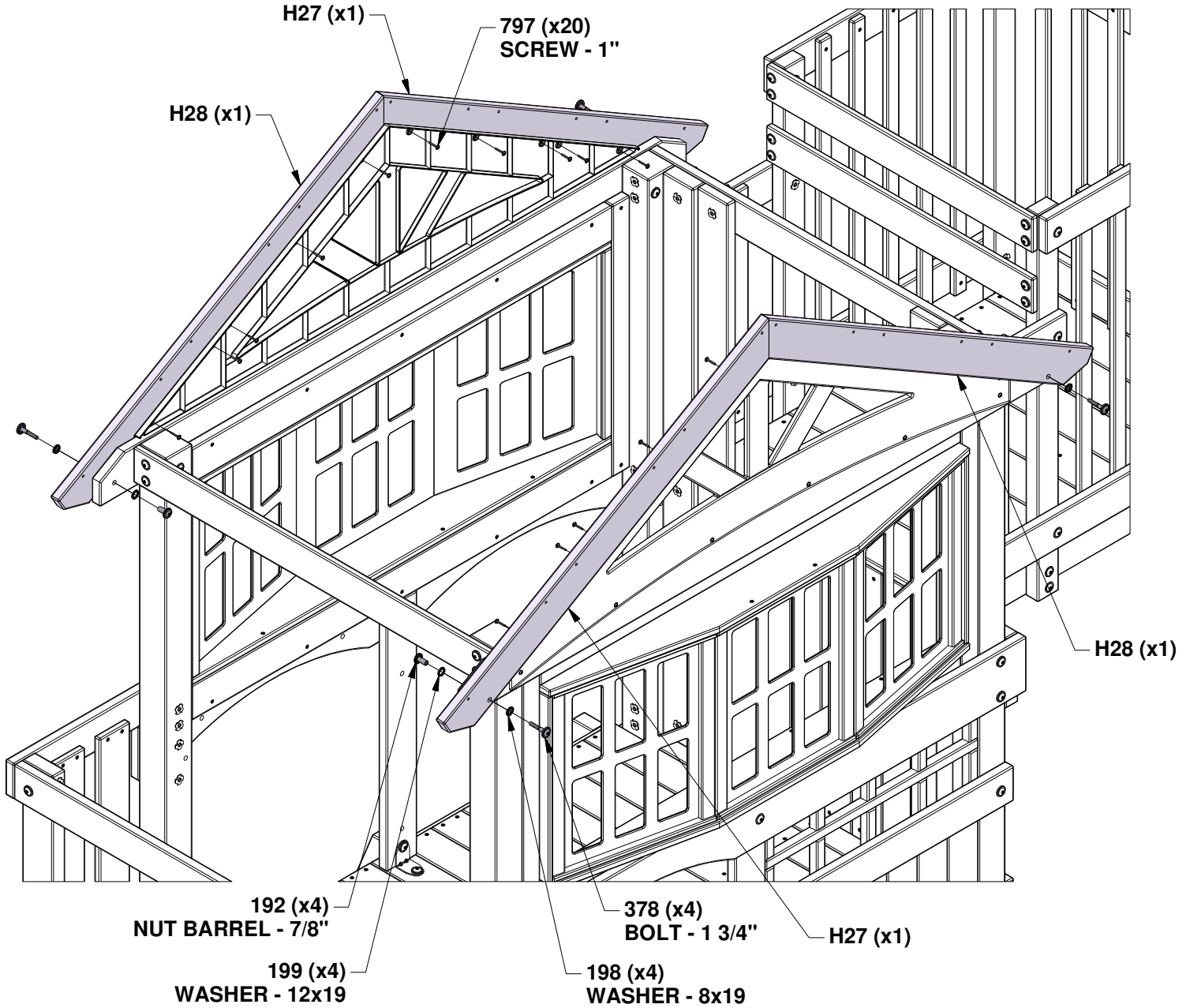

# STEP 52 - FORT ASSEMBLY

QTY	PART NUMBER	DESCRIPTION
8	H100391	SCREW PFH 8x2 BLK

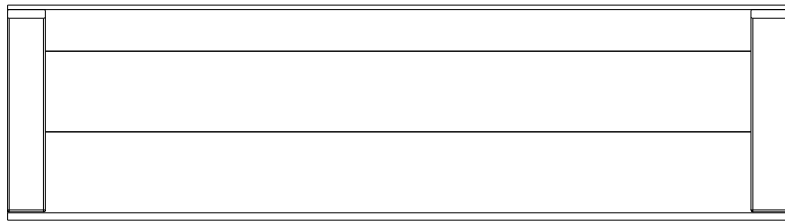

**RP1 PEAK ROOF PANEL - W2A03948**  
 (x2) 1 5/8"x13 3/8"x48 7/8" (42x341x1241)

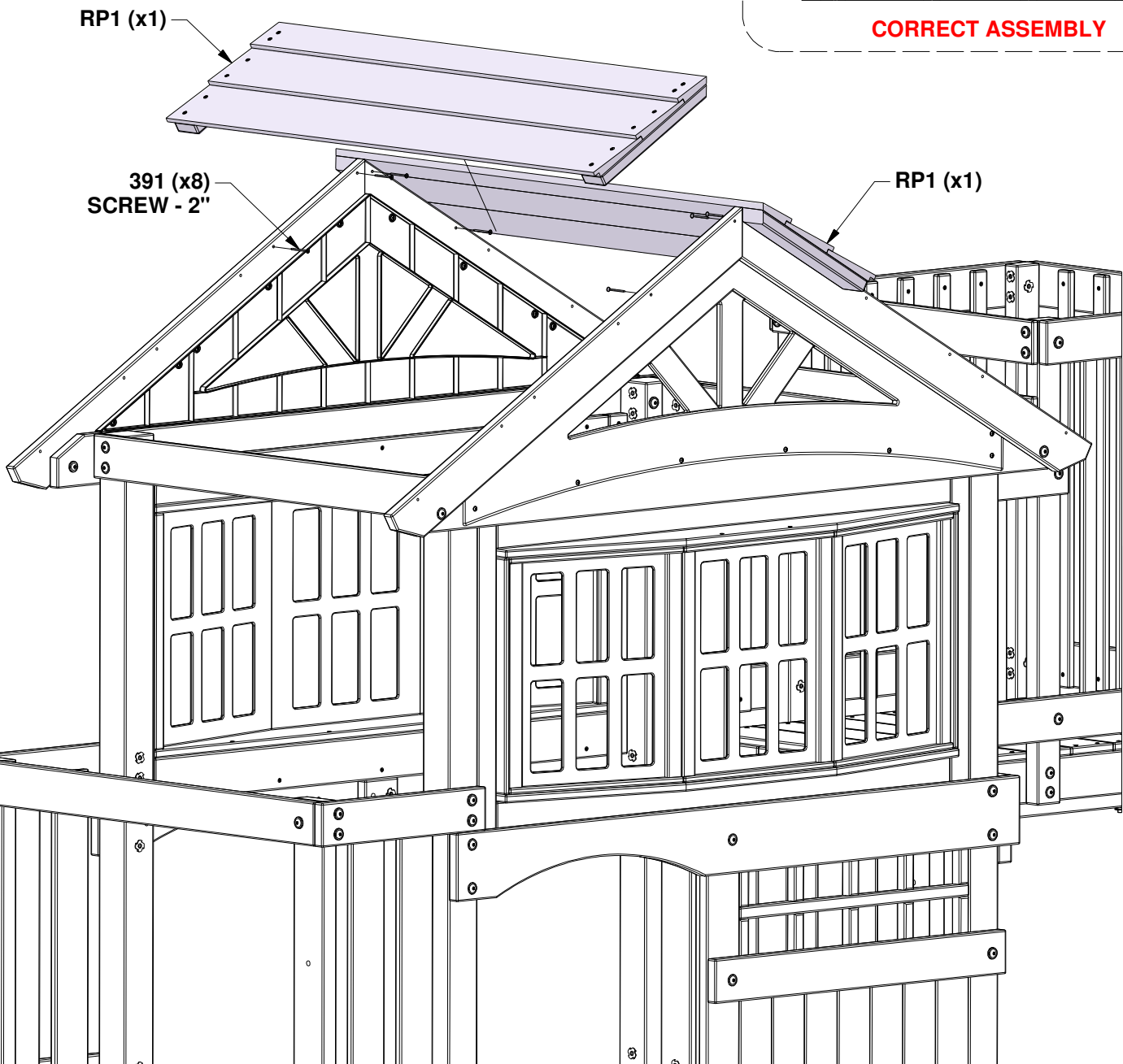
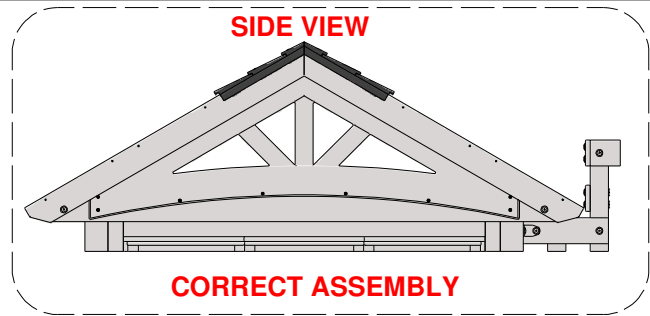

# STEP 53 - FORT ASSEMBLY

QTY	PART NUMBER	DESCRIPTION
8	H100391	SCREW PFH 8x2 BLK

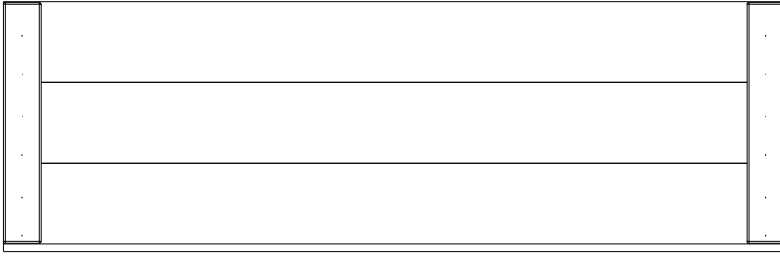

RP2 ROOF PANEL - W2A03947  
(x2) 1 5/8"x15 5/8"x59 3/8" (42x396x1241)

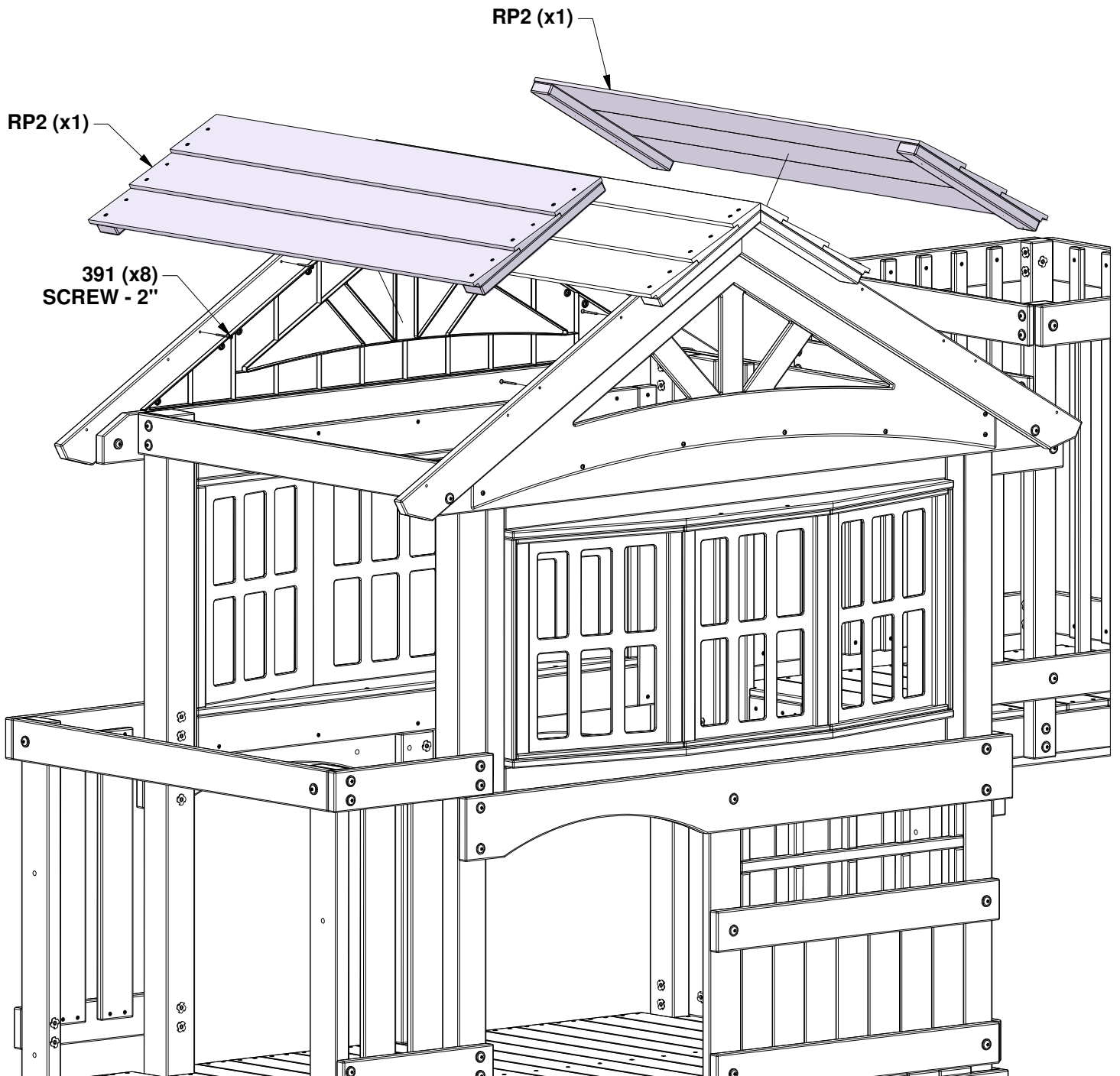

# STEP 54 - FORT ASSEMBLY

QTY	PART NUMBER	DESCRIPTION
8	H100391	SCREW PFH 8x2 BLK

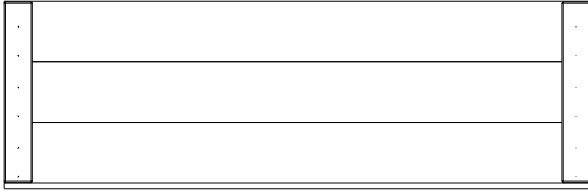

RP2 ROOF PANEL - W2A03947  
(x1) 1 5/8"x15 5/8"x59 3/8" (42x396x1241)

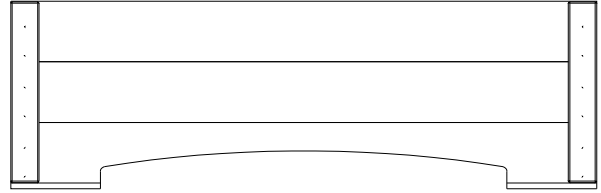

RP3 ROOF PANEL - W2A03949  
(x1) 1 5/8"x15 5/8"x59 3/8" (42x396x1241)

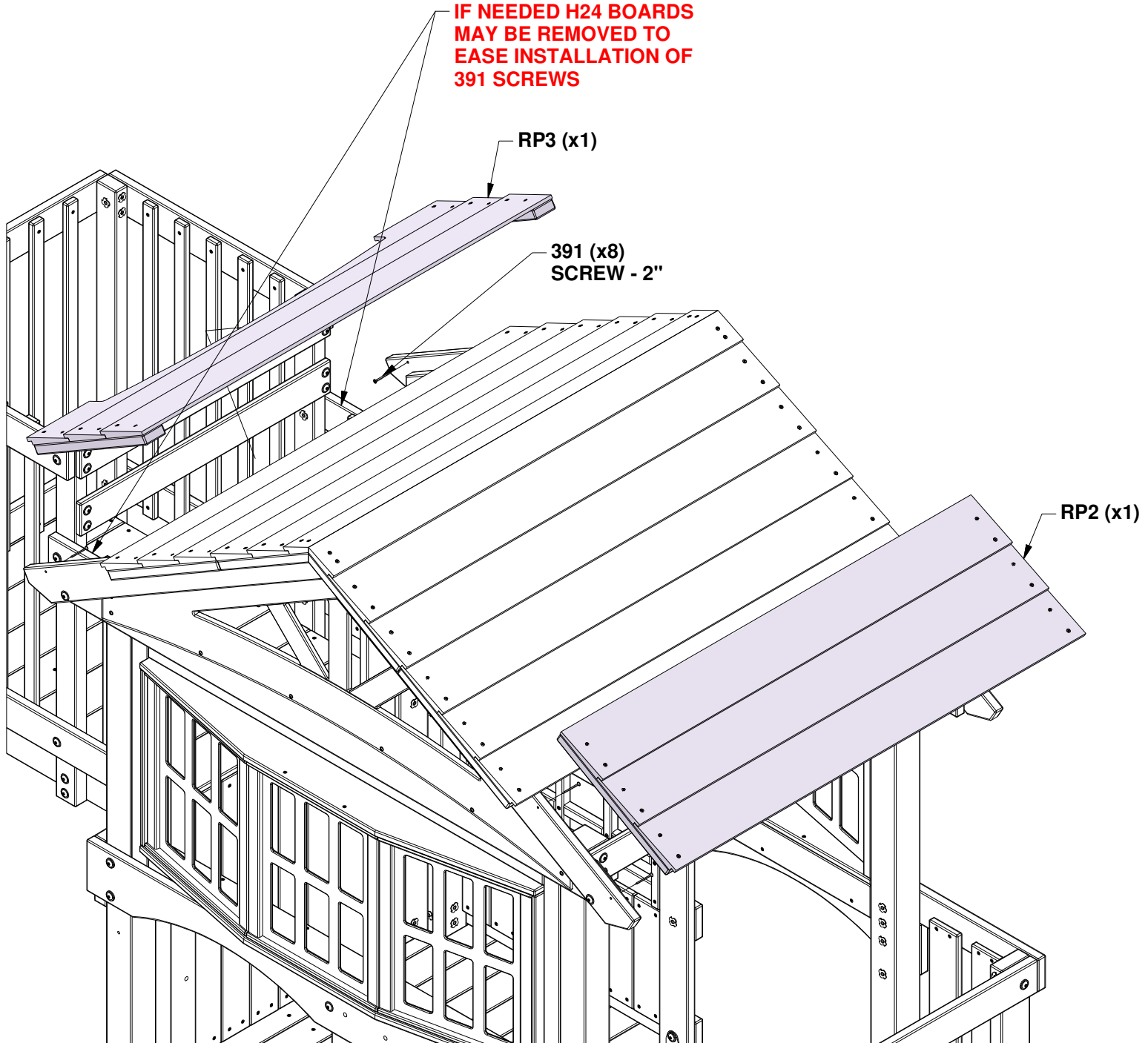

# STEP 55 - FORT ASSEMBLY

QTY	PART NUMBER	DESCRIPTION
2	H100200	SCREW PFH 8x1-1/2 BLK

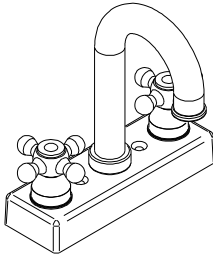

**A6P00024**  
(x1) **FAUCET KIT**

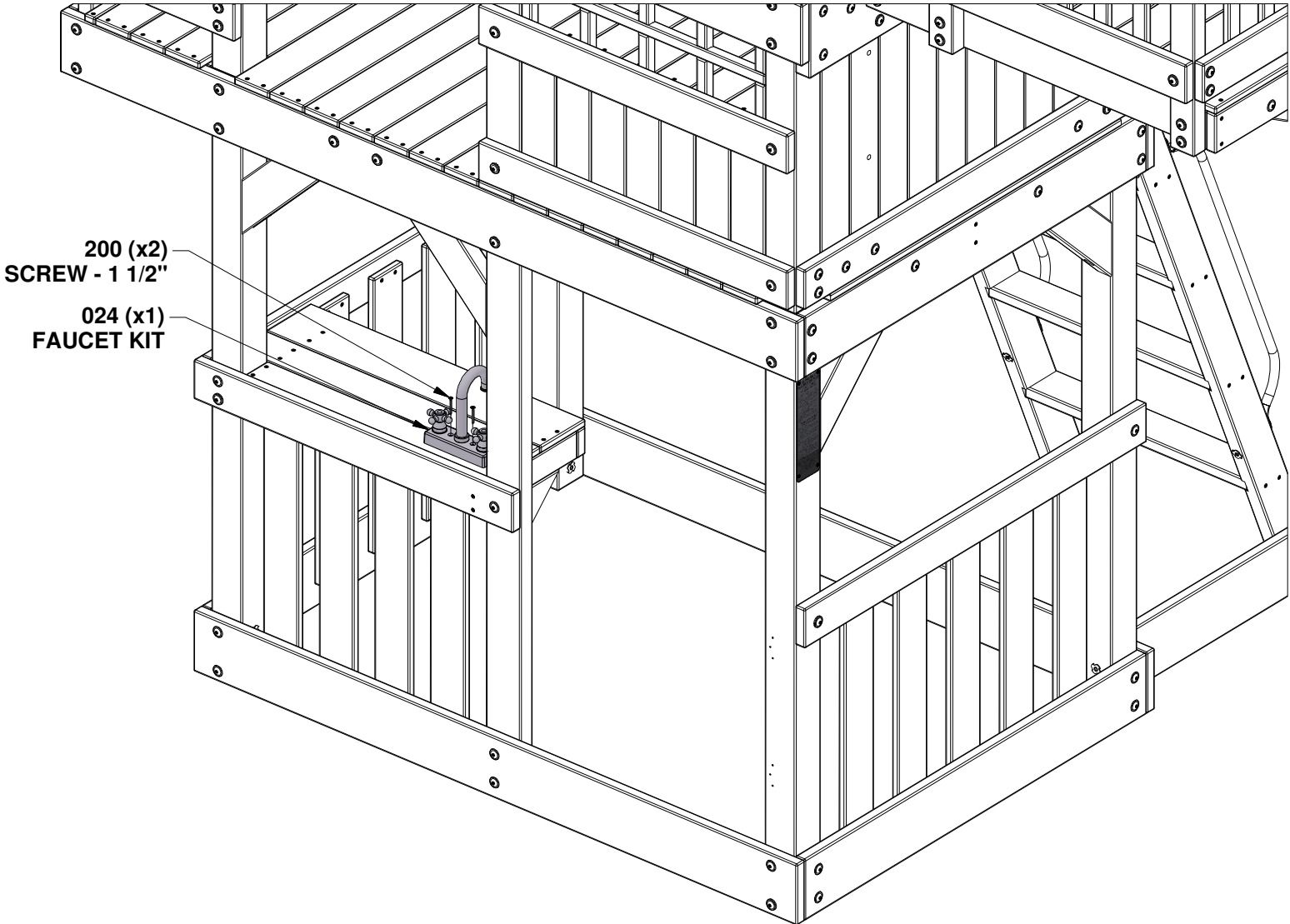
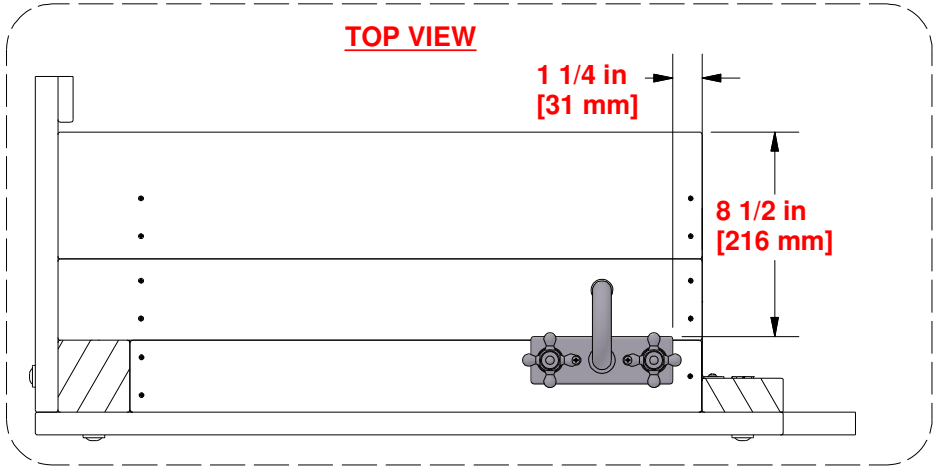

# STEP 56 - FORT ASSEMBLY

QTY	PART NUMBER	DESCRIPTION
2	H100202	SCREW PWH 8x5/8 BLK

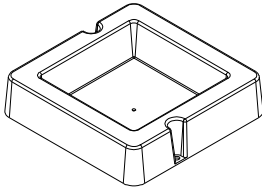

**A6P00032**  
(x1) **SURFACE MOUNT BASIN**

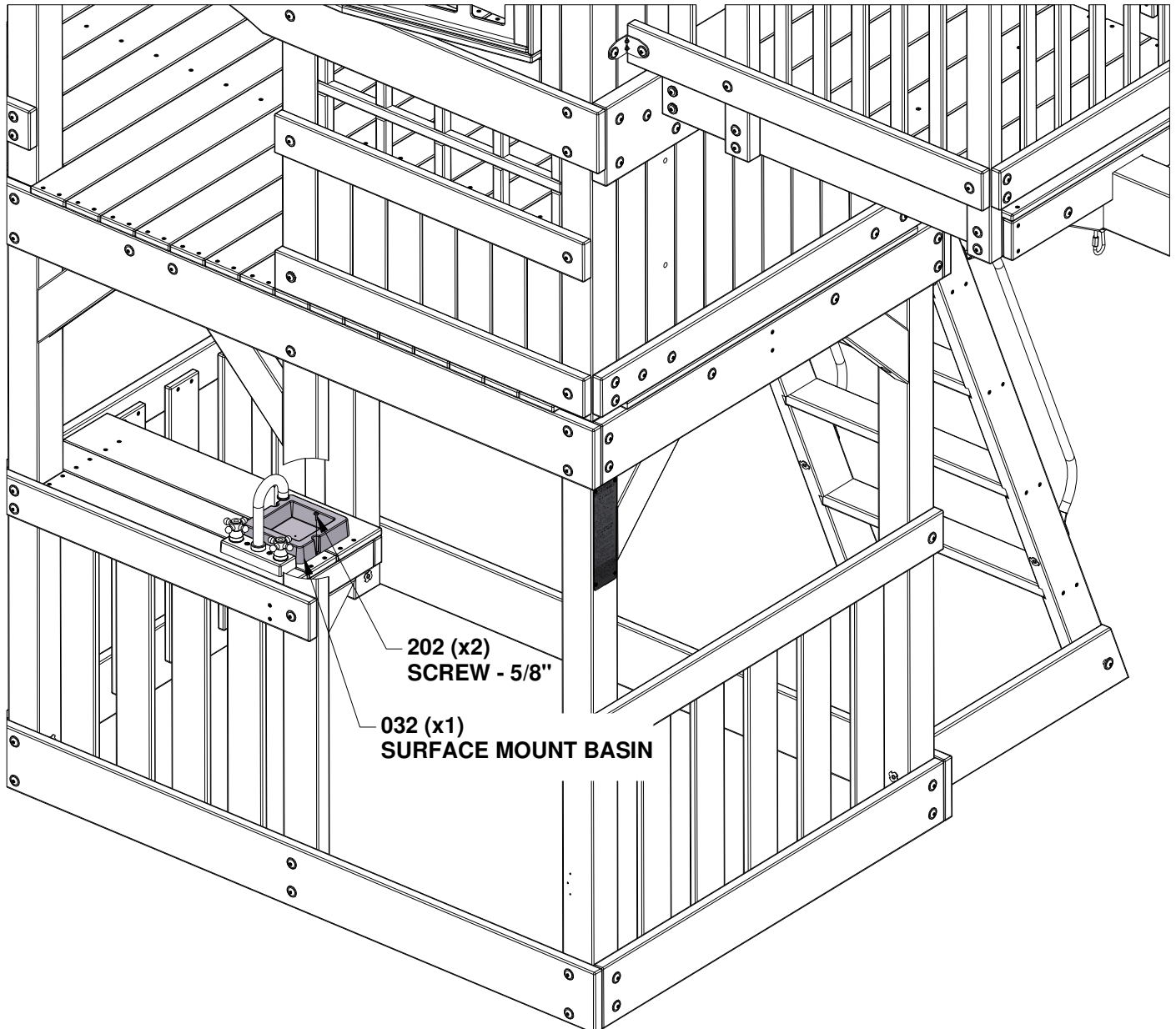
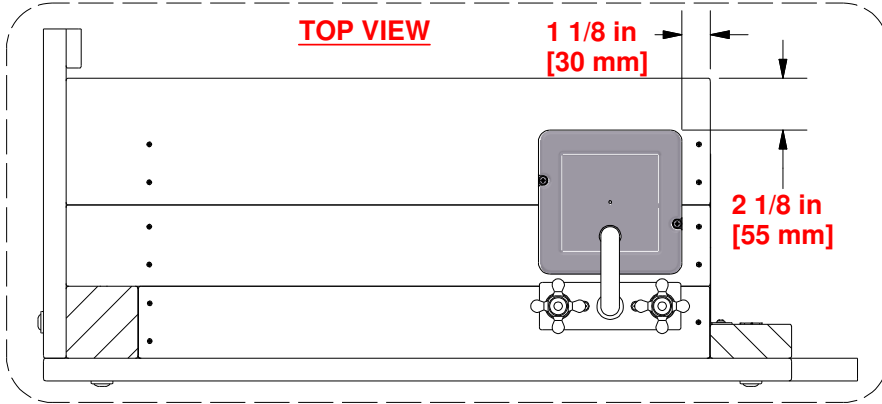

# STOVE ASSEMBLY

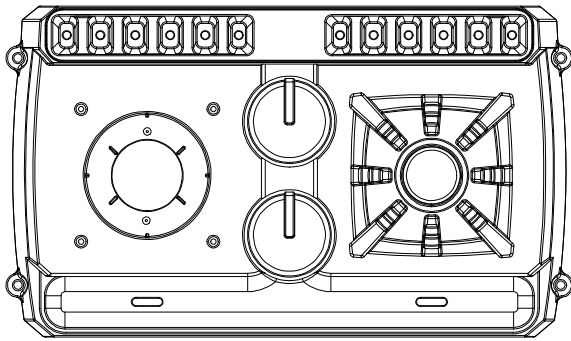

**A6P00335**  
(x1) **STOVE BASE**

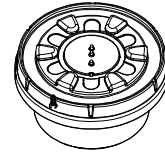

**A6P00330**  
(x1) **INDUCTIVE BURNER KIT**

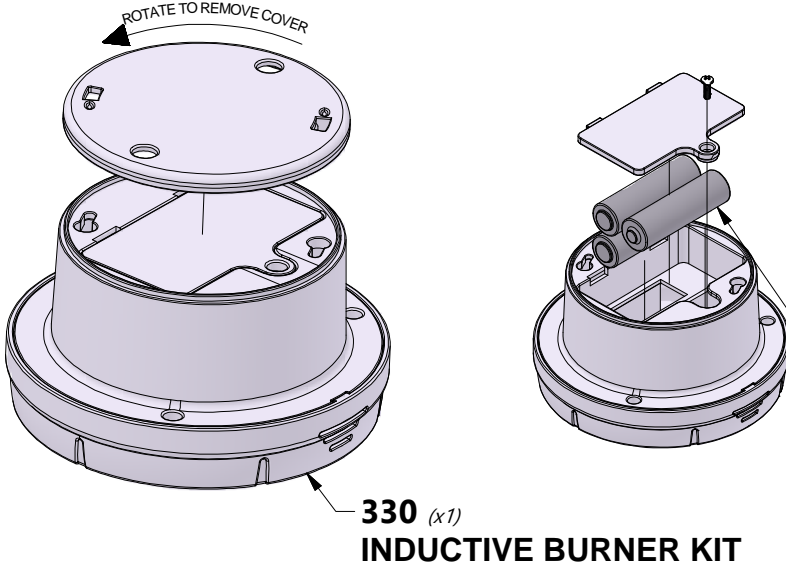

**330** (x1)  
**INDUCTIVE BURNER KIT**

**NOTE:** FCC LABEL

- DO NOT MIX OLD AND NEW BATTERIES.
- DO NOT MIX ALKALINE, STANDARD (CARBON-ZINC), OR RECHARGEABLE (NI-CAD, NI-MH, ETC.) BATTERIES.
- NON-RECHARGEABLE BATTERIES ARE NOT TO BE RECHARGED.
- ONLY BATTERIES OF THE SAME OR EQUIVALENT TYPE AS RECOMMENDED ARE TO BE USED.
- BATTERIES ARE TO BE INSERTED WITH THE CORRECT POLARITY.
- EXHAUSTED BATTERIES ARE TO BE REMOVED FROM THE TOY OR IF THE TOY IS TO BE LEFT UNUSED FOR A LONG TIME.
- THE SUPPLY TERMINALS ARE NOT TO BE SHORT-CIRCUITED.
- RECHARGEABLE BATTERIES ARE TO BE REMOVED FROM TOY BEFORE BEING CHARGED.
- RECHARGEABLE BATTERIES ARE ONLY TO BE CHARGED UNDER ADULT SUPERVISION.

"AA" BATTERY (x3)  
(Not Included)

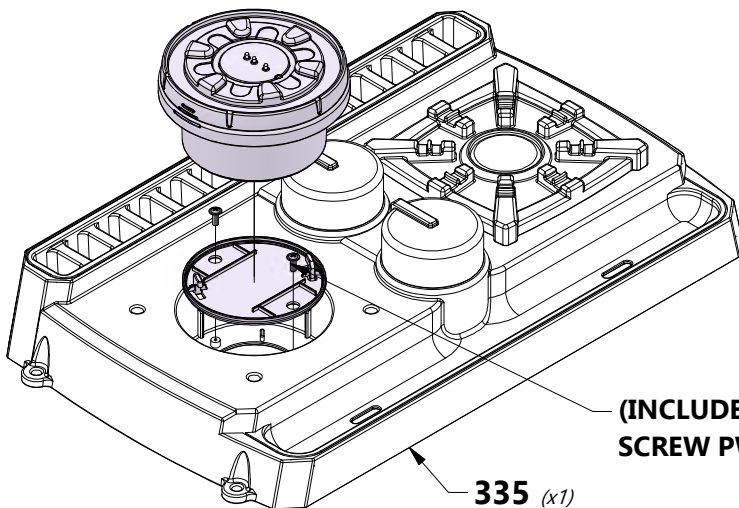

**(INCLUDED WITH KIT)** (x2)  
**SCREW PWH 4x5/16**

**335** (x1)  
**STOVE BASE**

**NOTE:**  
THIS DEVICE COMPLIES WITH PART 15 OF THE FCC RULES. OPERATION IS SUBJECT TO THE FOLLOWING TWO CONDITIONS:  
(1) THIS DEVICE MAY NOT CAUSE HARMFUL INTERFERENCE,  
(2) THIS DEVICE MUST ACCEPT ANY INTERFERENCE RECEIVED, INCLUDING INTERFERENCE THAT MAY CAUSE UNDESIRABLE OPERATION.

**NOTE:**  
FIRST INSTALL THE COVER REMOVED ABOVE WITH THE INCLUDED HARDWARE. INSTALL THE BURNER BY TWISTING IT CLOCKWISE TO LOCK IT IN PLACE.

# STEP 57 - FORT ASSEMBLY

QTY	PART NUMBER	DESCRIPTION
4	H100202	SCREW PWH 8x5/8 BLK

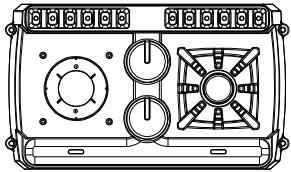

**A6P00335**  
*(x1)* STOVE BASE



**A6P00330**  
*(x1)* INDUCTIVE BURNER KIT

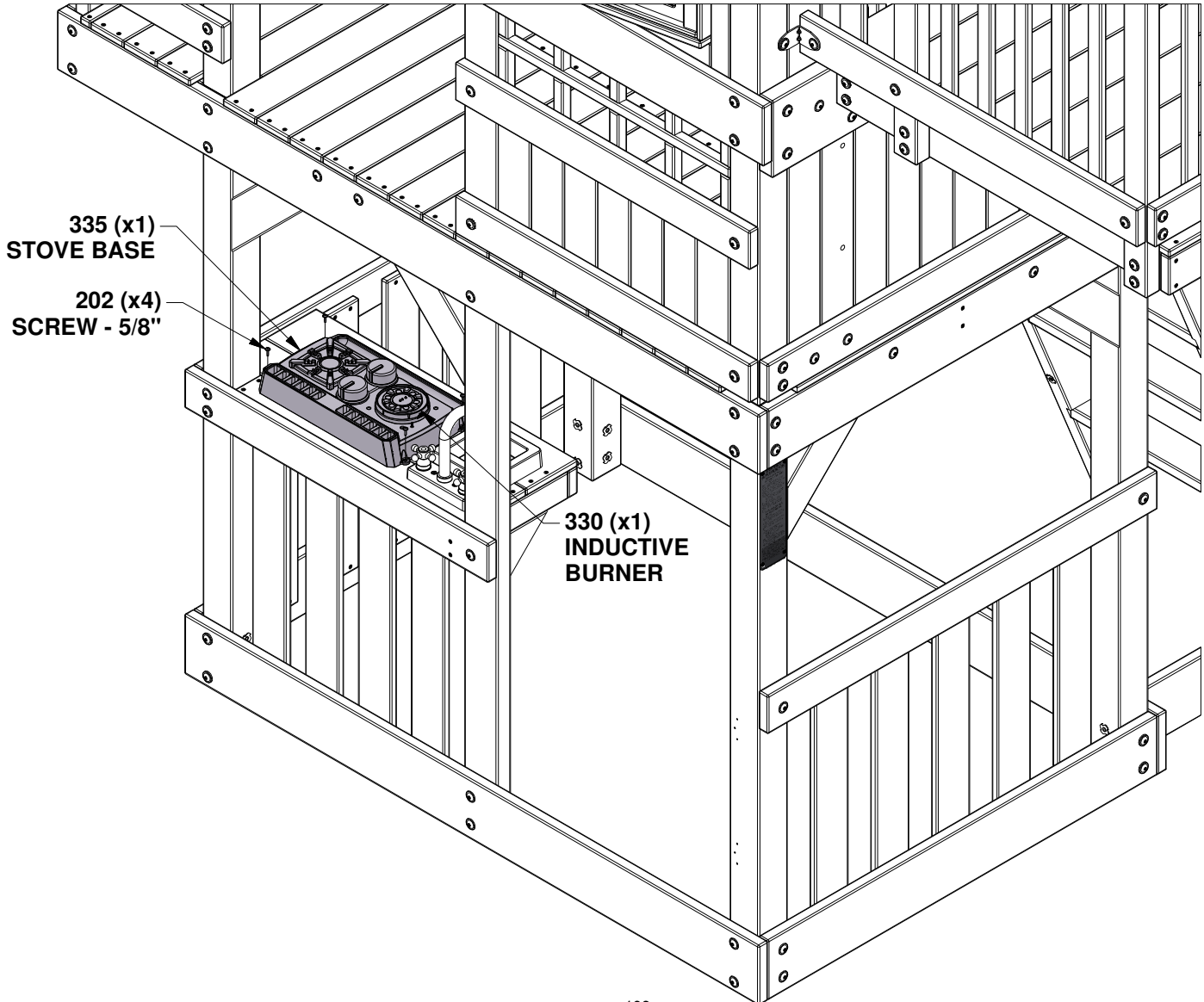
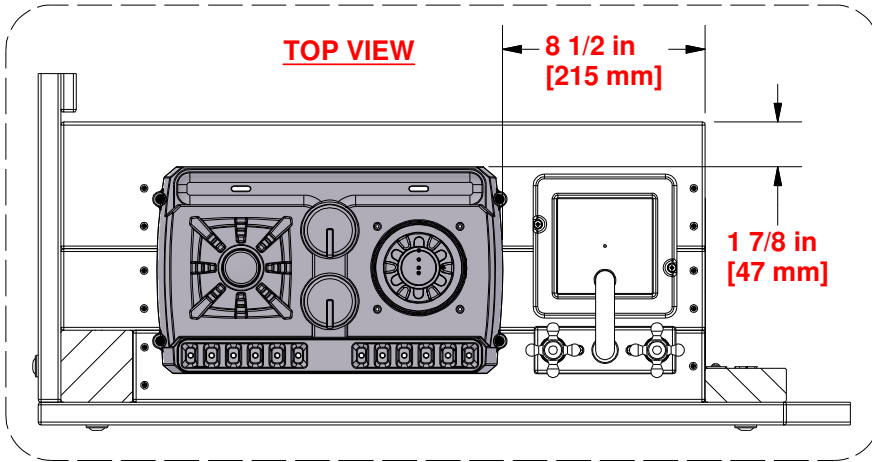

# STEP 58 - FORT ASSEMBLY

QTY	PART NUMBER	DESCRIPTION
6	H100797	SCREW PWH 8x1 BLK
6	H100806	SCREW POH-MS 8/32x1 1/8 BLK
6	H101272	NUT BARREL PPH 8x32 BLK

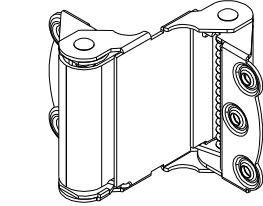
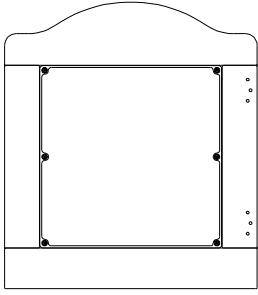

**A4M01089**  
(x2) **SPRING HINGE**

**DR1 DOOR ASSEMBLY - W2A03798**  
(x1) 1 1/4"x21 1/16"x23 7/8" (32x535x606)

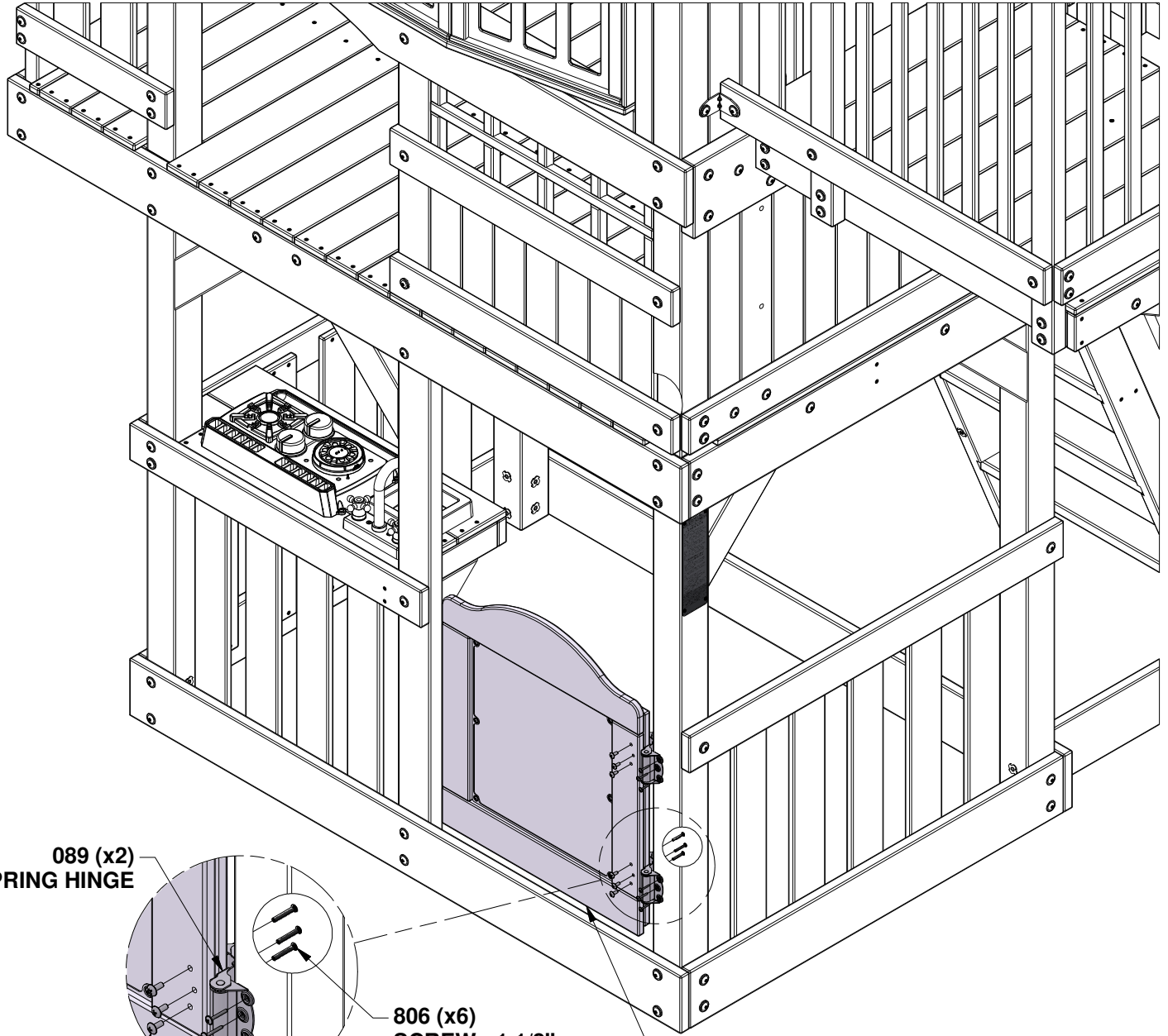

089 (x2)  
**SPRING HINGE**

1272 (x6)  
**NUT BARREL - 1/2"**

797 (x6)  
**SCREW - 1"**

806 (x6)  
**SCREW - 1 1/8"**

DR1 (x1)

**TIP:  
ALIGN PILOT HOLES**

# STEP 59 - FORT ASSEMBLY

QTY	PART NUMBER	DESCRIPTION
6	H100379	T-NUT 5/16 BLK
4	H100407	BOLT WH 5/16x1 1/2 BLK
2	H100468	BOLT WH 5/16x1 BLK
2	H100471	LAG SCREW WH 5/16x1 1/2 BLK

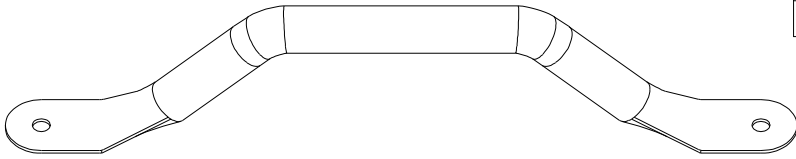

**A4M02249**  
(x4) **HAND GRIP METAL GREY 381 C/C**

**INSTALL T-NUTS IN WOOD FIRST**

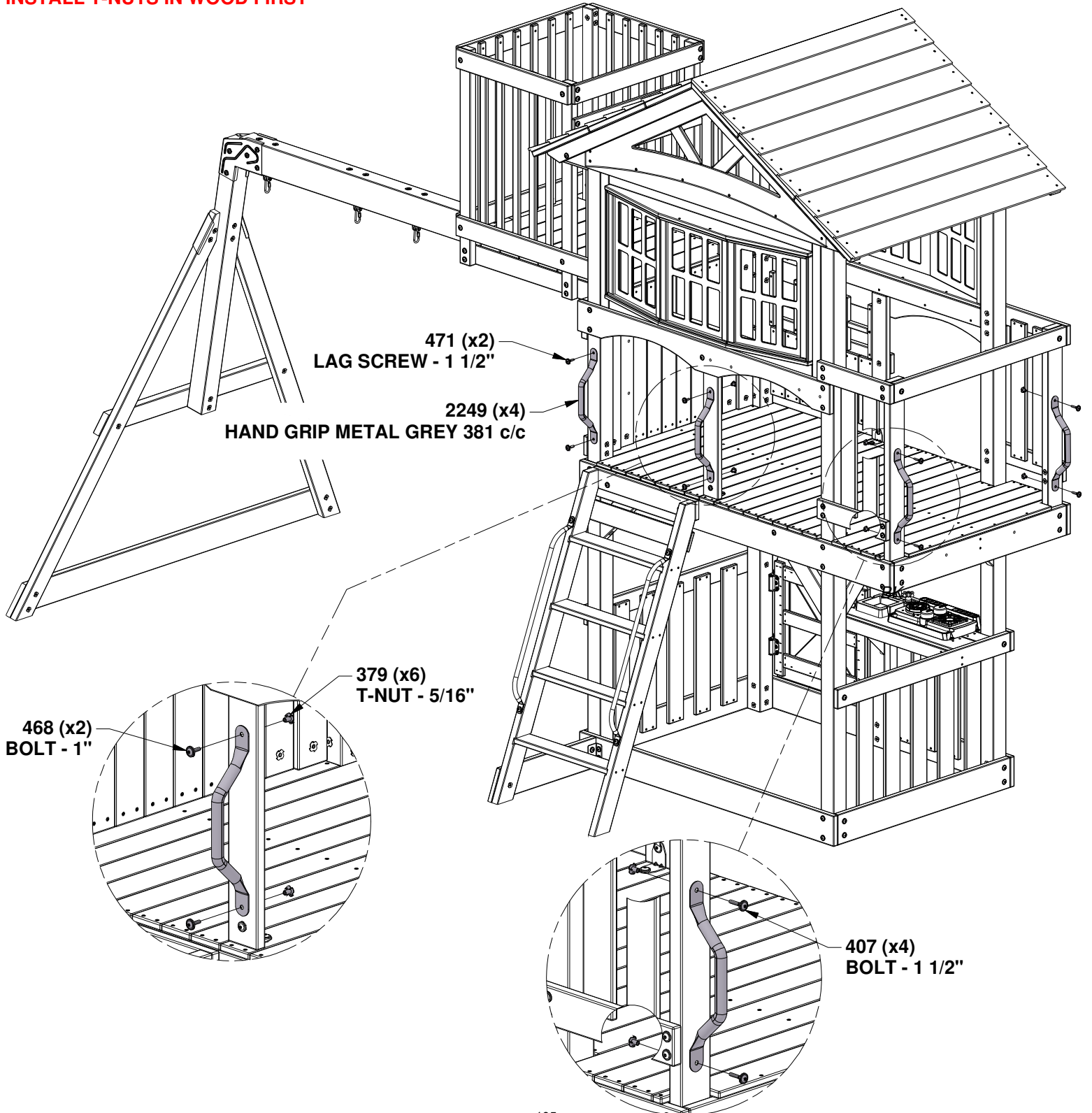

# STEP 60 - FORT ASSEMBLY

QTY	PART NUMBER	DESCRIPTION
4	H100468	BOLT WH 5/16x1 BLK
4	H100379	T-NUT 5/16 BLK

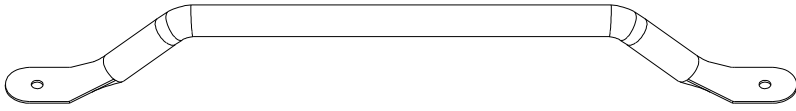

**A4M02251**  
(x2) **LADDER RUNG 578 GREY**

**INSTALL T-NUTS IN WOOD FIRST**

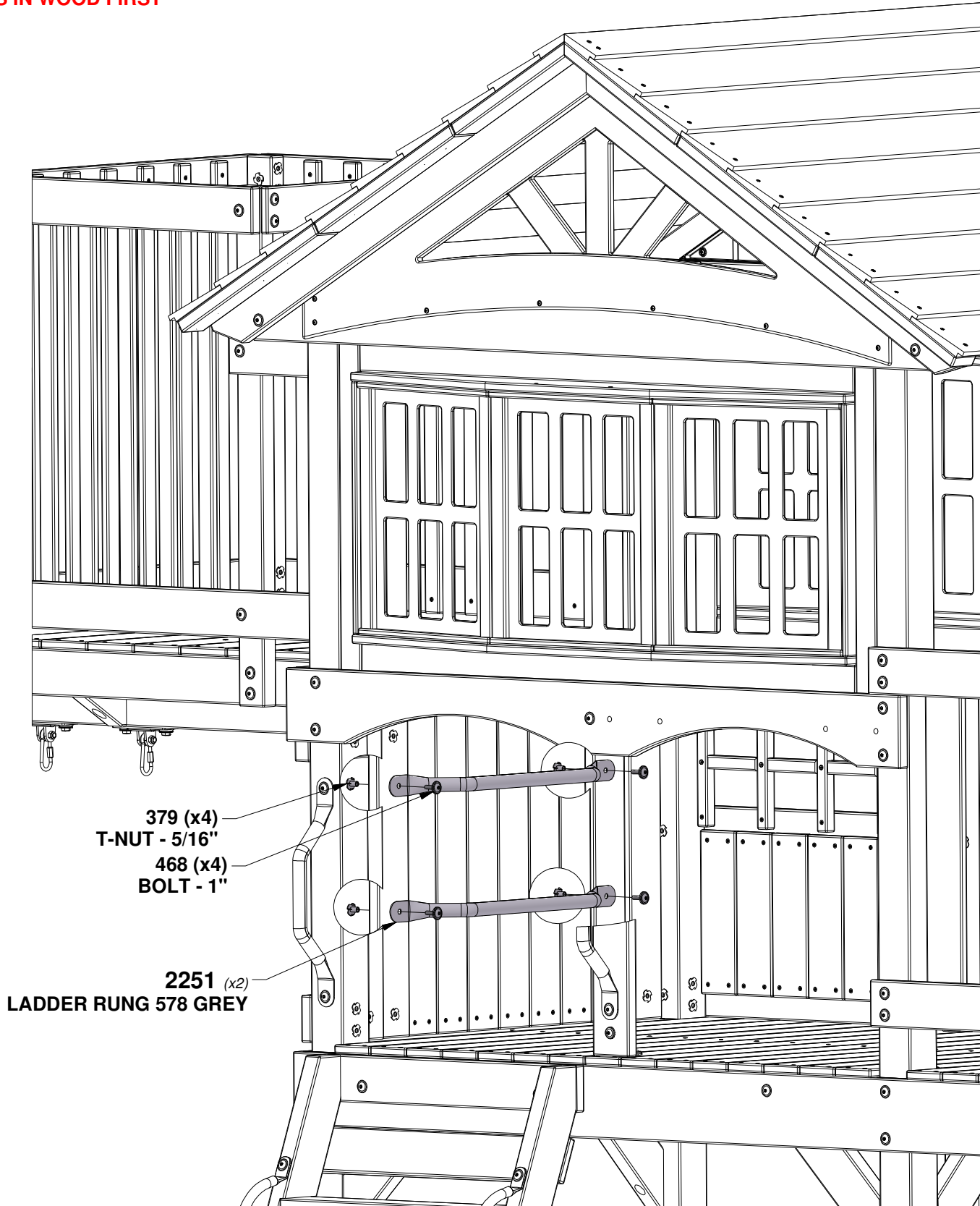

# STEP 61 - FORT ASSEMBLY

QTY	PART NUMBER	DESCRIPTION
1	H100378	BOLT WH 5/16x1 3/4 BLK
4	H100379	T-NUT 5/16 BLK
2	H100468	BOLT WH 5/16x1 BLK
1	H100512	BOLT WH 5/16x4 BLK

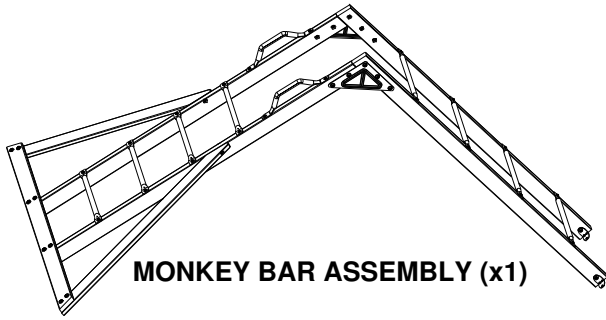

**INSTALL T-NUTS IN WOOD FIRST**

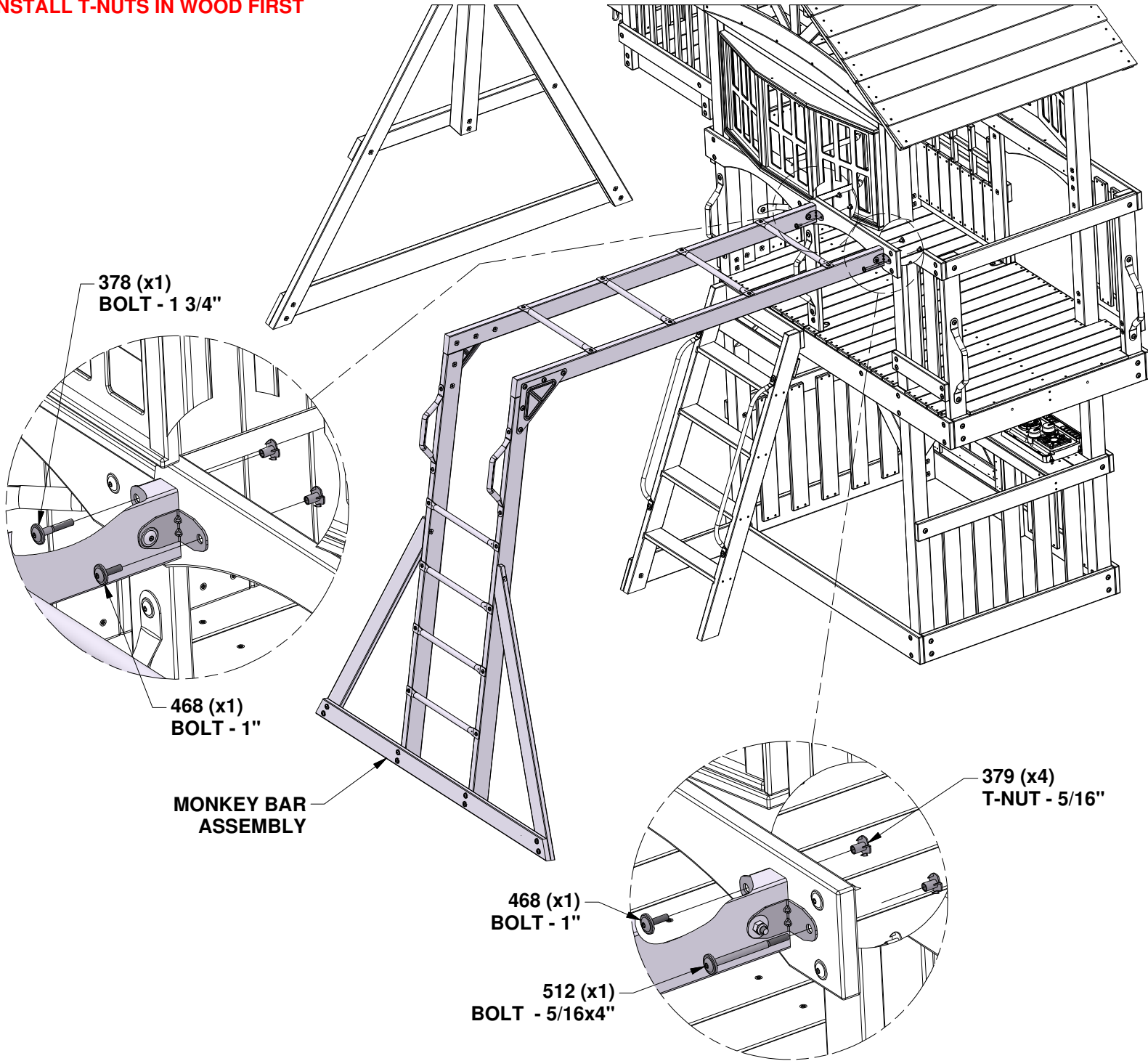

# STEP 62 - FORT ASSEMBLY

QTY	PART NUMBER	DESCRIPTION
2	H100387	SCREW PFH 8x1 1/4 BLK

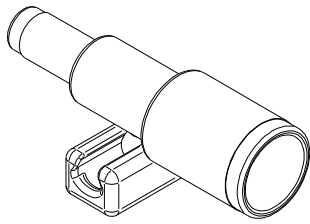

**A6P00596**  
(x1) **TELESCOPE GREY**

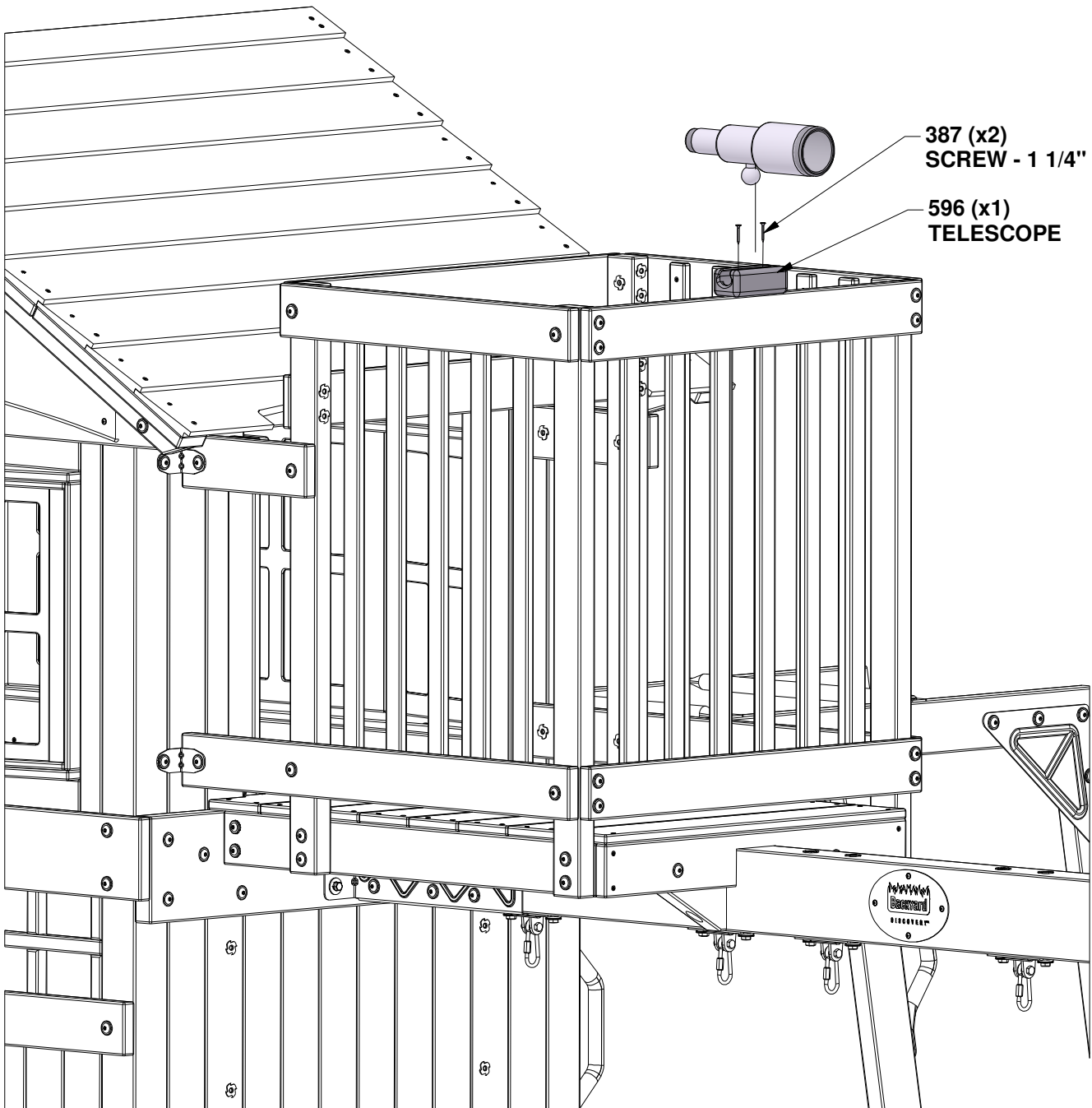

# STEP 1 - WEB SWING ASSEMBLY

QTY	PART NUMBER	DESCRIPTION
4	H100831	NUT BARREL PTH BLK 1/4x3/4
4	H100832	BOLT PTH 1/4x3/4

**IMPORTANT: SLIDE ROPE LOOPS OVER TUBE ENDS FIRST!**

SLIDE NARROW END OF TUBES INTO LARGER OPENING AFTER SLIDING ROPE LOOPS ONTO TUBES.

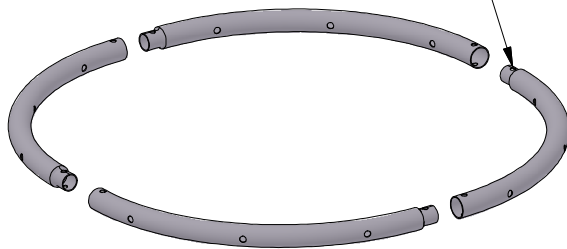

NOTE: ROPE WEBBING NOT SHOWN IN ILLUSTRATION FOR CLARITY.

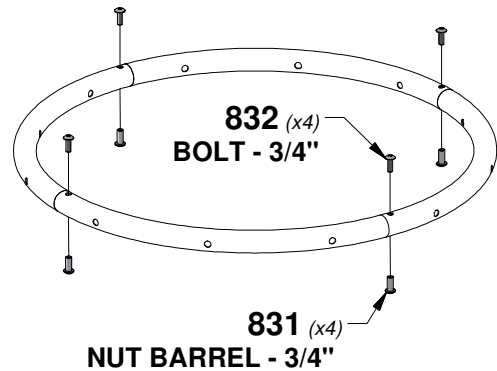

NOTE: IT IS IMPORTANT THAT THE WEB SWING HANG LEVEL.

TO ENSURE STRAIGHT SWINGING MOTION, ADJUST BOTH "S" BRACKETS UNTIL WEB SEAT IS LEVEL.

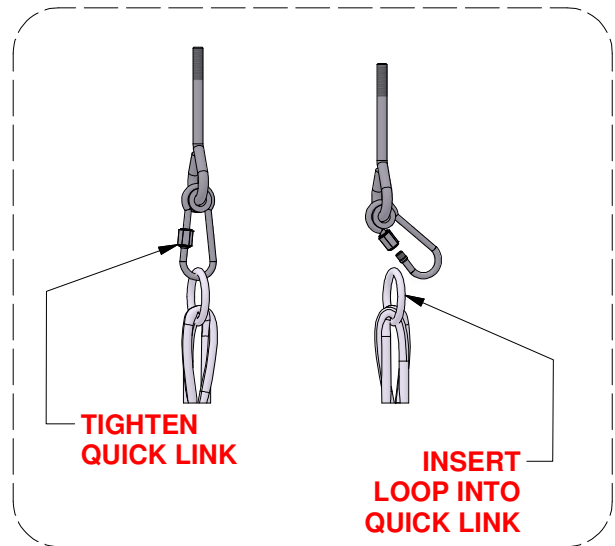

SWING MUST BE SET AT A MINIMUM OF 8 INCHES OFF THE GROUND WHEN INSTALLED.

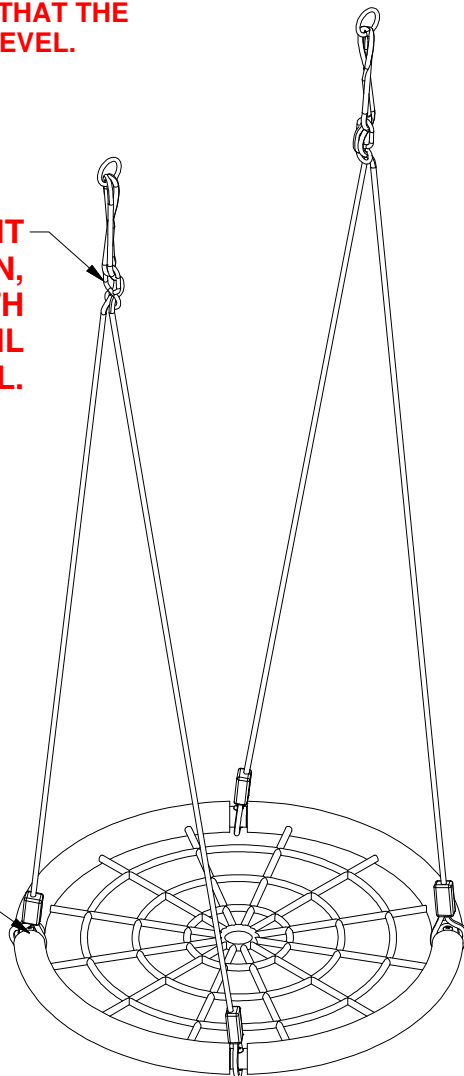

# STEP 63 - FORT ASSEMBLY



**A4M02256**  
(x4) **CHAIN BLACK 51.25"**

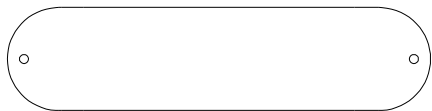

**A6P00595**  
(x2) **SWING SEAT GREY 22"**

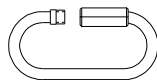

**A4M00633**  
(x4) **QUICK LINK BLK**



**A4M01126**  
(x1) **26" WEB SWING**

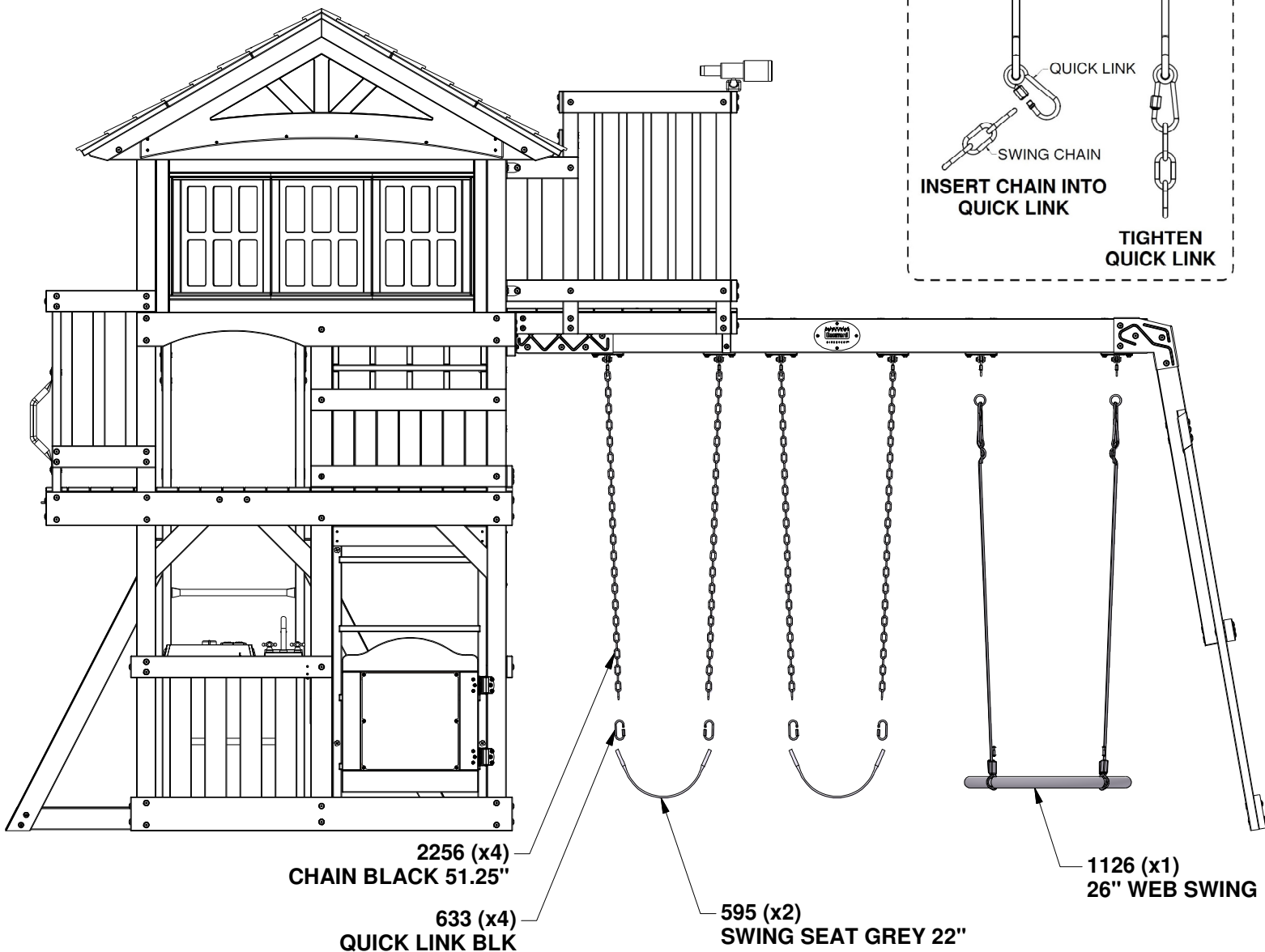

# STEP 64 - FORT ASSEMBLY

QTY	PART NUMBER	DESCRIPTION
2	H100198	WASHER LOCK EXT 8x19 BLK
2	H100378	BOLT WH 5/16x1 3/4 BLK

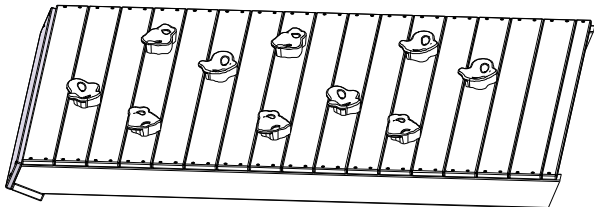

**ROCK WALL ASSEMBLY (x1)**

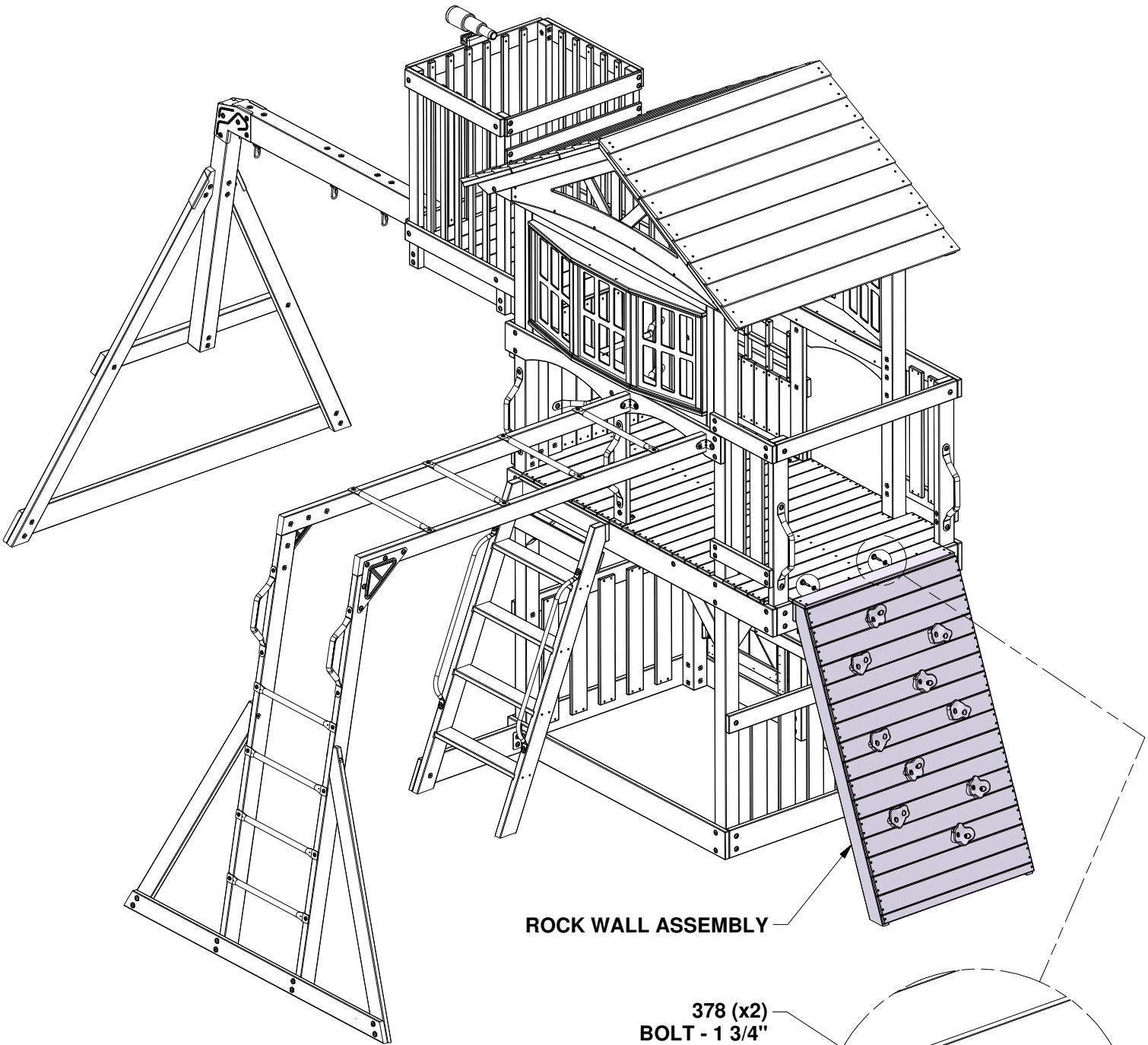

**ROCK WALL ASSEMBLY**

- 378 (x2)  
BOLT - 1 3/4"
- 198 (x2)  
WASHER - 8x19

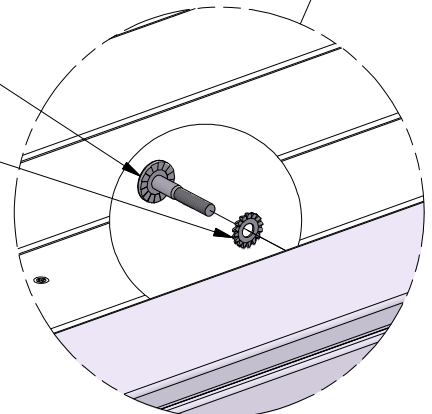

# STEP 65 - FORT ASSEMBLY

QTY	PART NUMBER	DESCRIPTION
2	H100468	BOLT WH 5/16x1 BLK
2	H100379	T-NUT 5/16 BLK

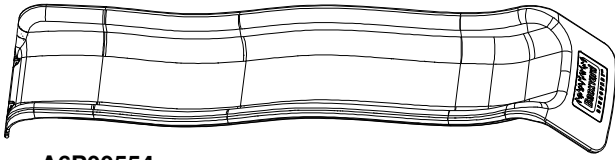

**A6P00554**  
(x1) **8' BLOW MOLDED SLIDE - GREY**

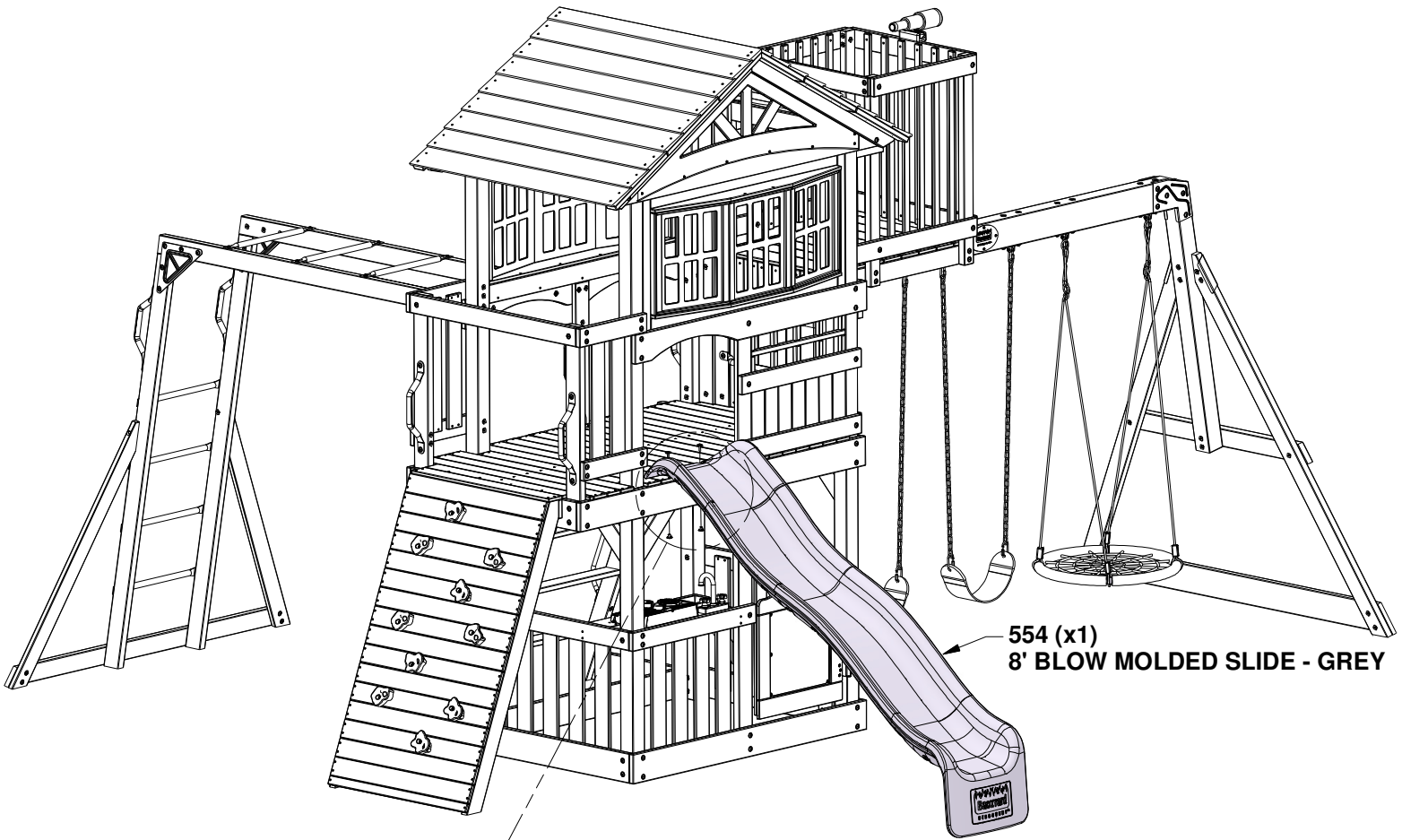

**468 (x2)**  
**BOLT - 1"**

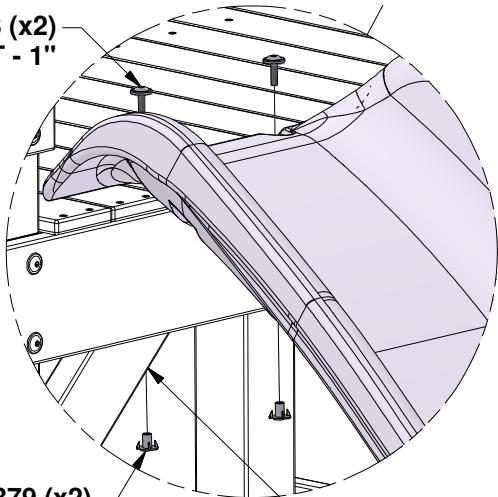

**379 (x2)**  
**T-NUT - 5/16"**

**IF NEEDED E01 ANGLE BRACES MAY BE REMOVED TO EASE INSTALLATION OF 379 T-NUT.**

**3 1/4 in**  
**[82 mm]**

**1 7/8 in**  
**[49 mm]**

**1 7/8 in**  
**[49 mm]**

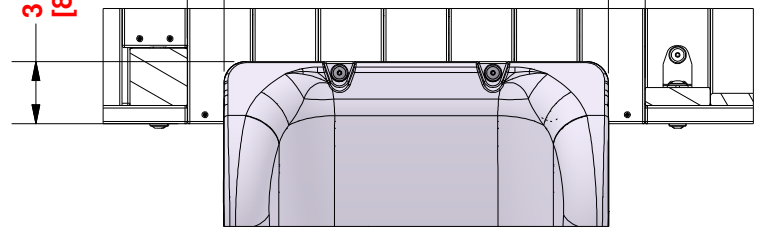

**TOP VIEW**

**CENTER SLIDE IN OPENING USING DIMENSIONS SHOWN. USING SLIDE AS A TEMPLATE, DRILL (2) 3/8" [10mm] HOLES THROUGH DECK FOR HARDWARE.**

# STEP 66 - FORT ASSEMBLY

QTY	PART NUMBER	DESCRIPTION
9	H100459	BOLT WH 5/16x1 1/4 BLK
8	H100379	T-NUT 5/16 BLK
1	H100192	NUT BARREL WH 5/16x7/8 BLK
1	H100199	WASHER LOCK EXT 12x19 BLK

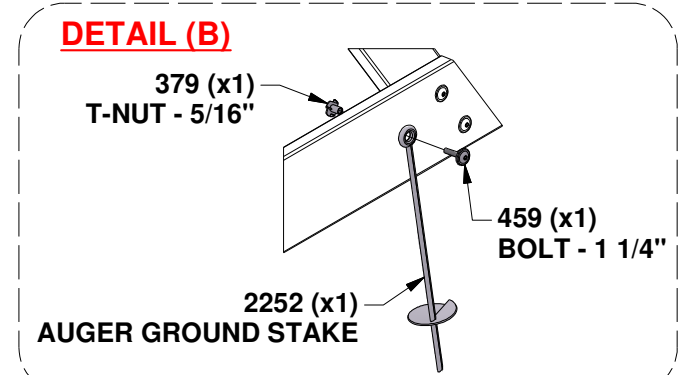
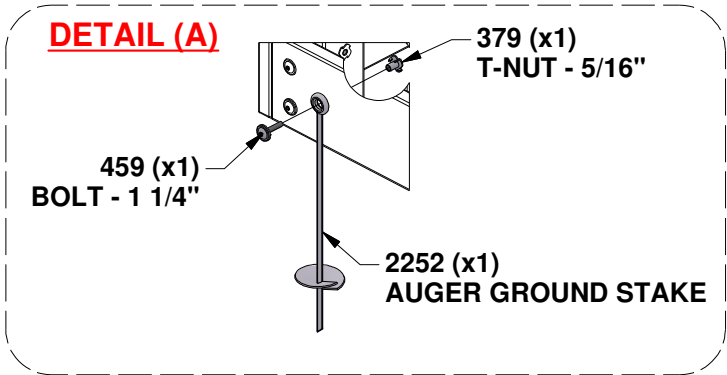

**TWIST GROUND STAKE INTO GROUND WHERE SHOWN. USING GROUND STAKE AS A GUIDE, DRILL (1) 3/8" [10 mm] HOLE FOR HARDWARE. (DETAILS A,B & D)**

