

Kräus[®]

INSTALLATION MANUAL

Automatic Sensor Trash Can

KTCS-14

Congratulations on the purchase of your new Kraus® plumbing fixture!

Please keep the box and packaging materials until your product is completely installed. If you have any questions, require technical assistance or have any problems with your product:

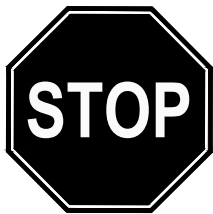

DO NOT RETURN TO STORE

**Please contact our Customer Service Team
1-800-775-0703 / customerservice@kraususa.com**

Have the model number available and retain a copy of your receipt with purchase date for reference.

If for any reason this product does not meet your expectations, please be sure to repack this product in the original box and packaging material to avoid damage during transit.

For technical assistance or replacement parts, please contact Kraus Customer Service and one of our representatives will be happy to help:

Toll-Free: 800-775-0703 or Customerservice@kraususa.com

Diagram and Parts List

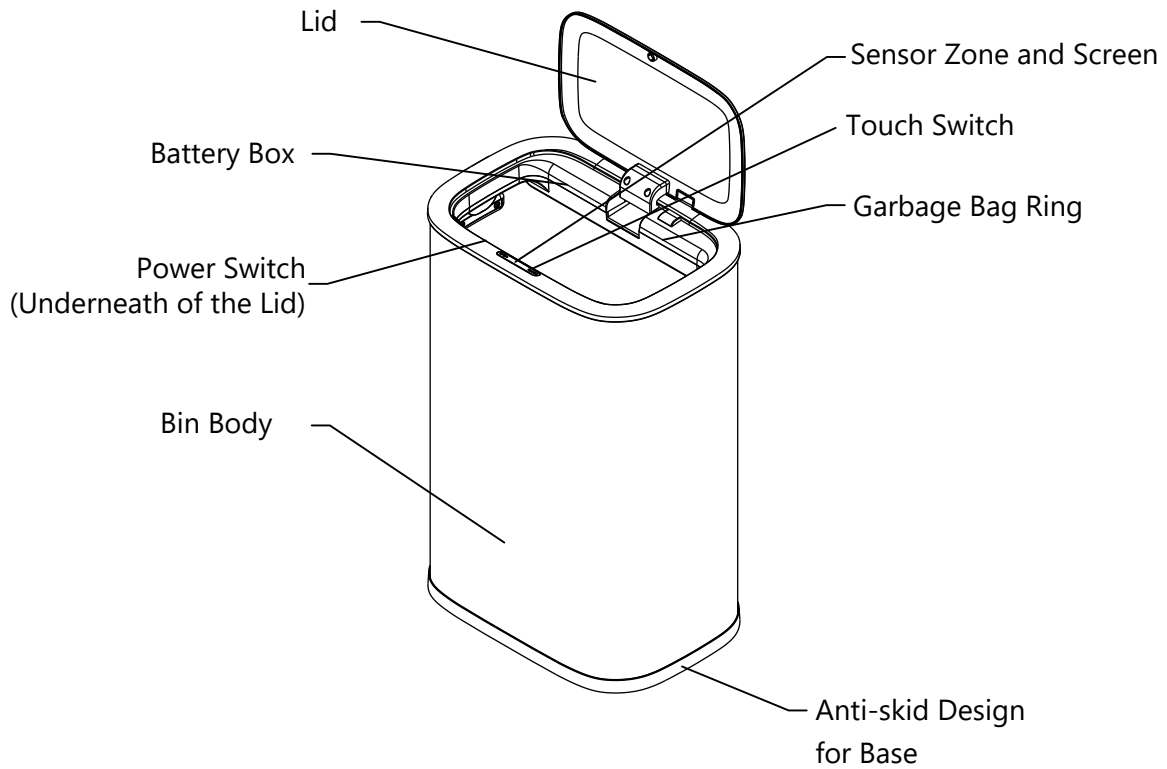

Dimensions

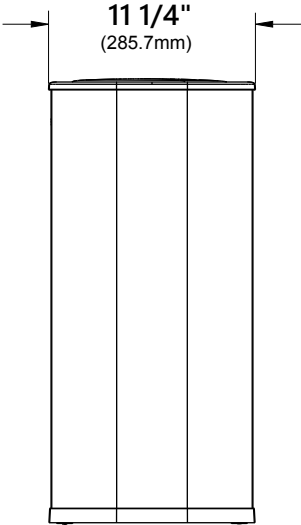
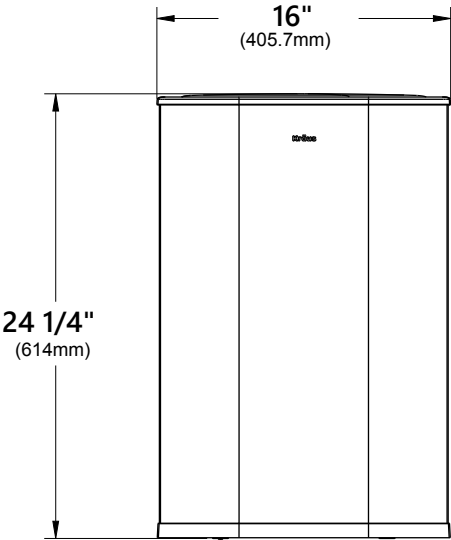
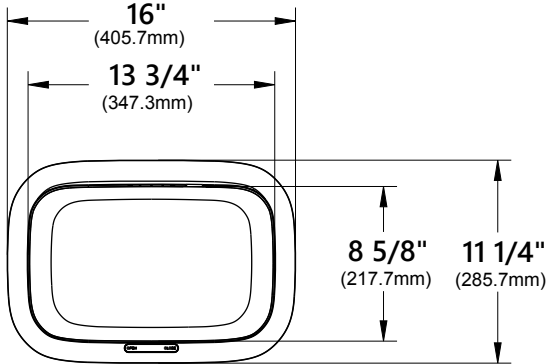

Step 1. Check All Parts

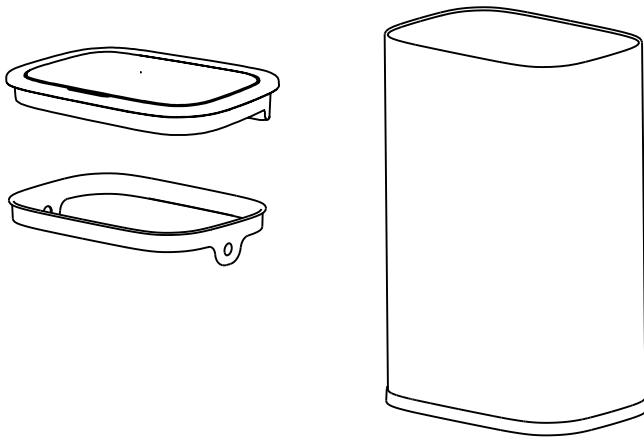

Remove the lid and garbage bag ring, turn the power switch face to you.

Step 2. Install Batteries

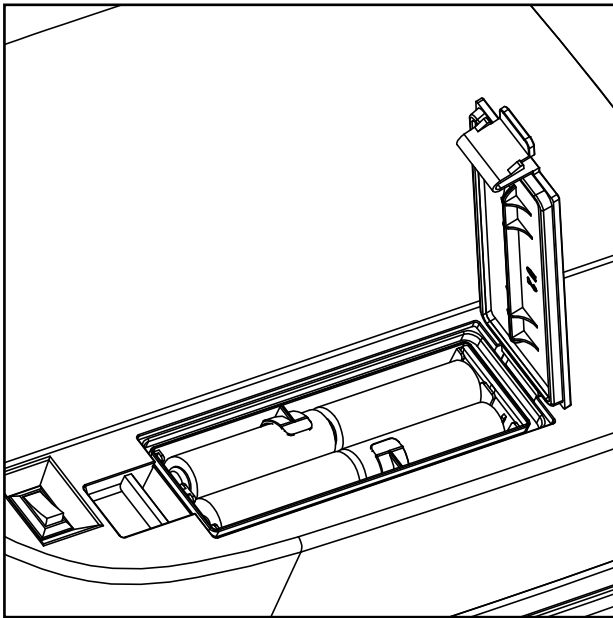

Install 4 AA batteries into the case according to the "+,-" instruction and seal the cover.

Step 3. Open the Power Switch

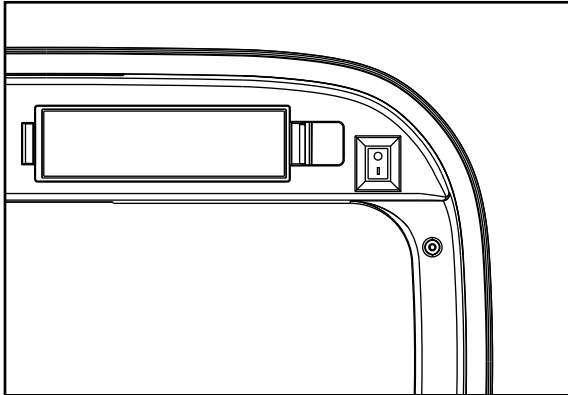

Press the power switch on the back side of the lid to "I" and the automatic sensor system will start to work.

Step 4. Instructions of Sensing Function

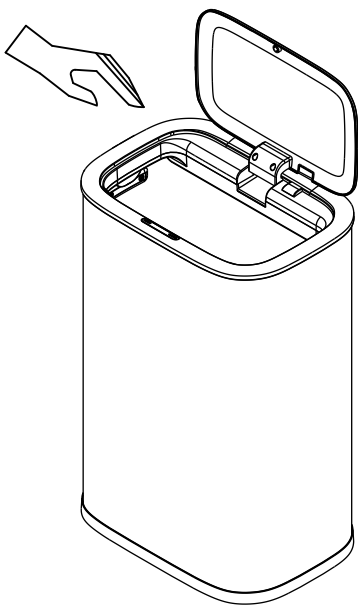

When garbage or any part of your body is in the sensing area (about 8 inches distance & 10-15 degrees forward), lid will open automatically. After leaving the sensing area, the lid will automatically close after 5 seconds.

Step 5. Secure the Trash Bag

Remove the Bag Securing Ring before taking out the full trash bag.

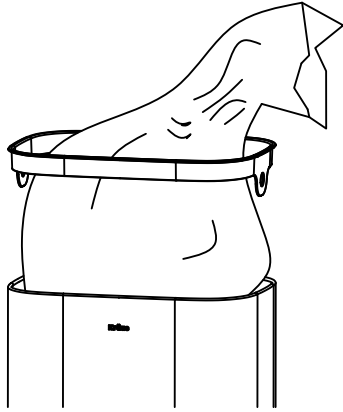

5a. Select your Preferred Trash Bag and Place it inside the Trash Can.

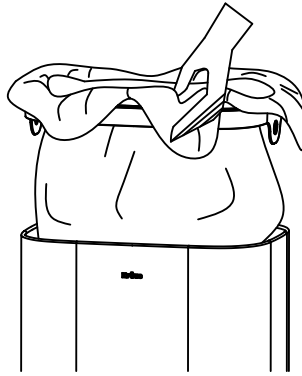

5b. Wrap the lip of the trash bag around Garbage Bag Ring.

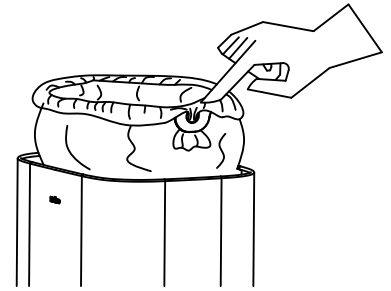

5c. Push the extra part of the trash bag into two holes, and replace Garbage Bag Ring and the lid.

Touch Button

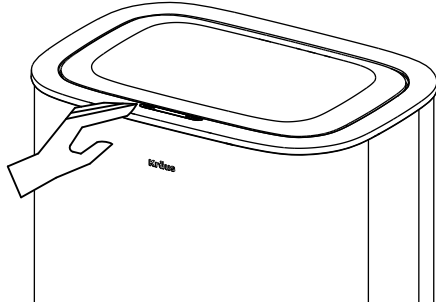

1. Press the OPEN button on the screen to keep the lid in the open position.
2. Press the CLOSE button to close the lid.
3. After you press the OPEN button, the lid will close automatically after 15 minutes if there is no operation.

Precautions

1. When you install batteries, please take note of the "+" and "-" instructions.
2. Be sure to use a clean cloth to clean the trash bin. Please do not use too much water on the trash bin. Water can damage the inner elements. Do not power on if water goes inside of the trash bin.
3. Please do not push or flip the lid to prevent the lid from damage.
4. Please replace the batteries in over time to avoid liquid leaking. This situation may damage the electric elements.
5. Avoid using the trash bin under direct sunlight or wet surroundings.
6. Keep the sensing area clean to ensure proper function of the sensor.
7. Please don't mix acidic batteries and alkaline batteries. Also, do not mix rechargeable batteries and disposable batteries.
8. Please do not attempt to repair the trash bin or replace parts by yourself. This will void the warranty.

Replacement Parts

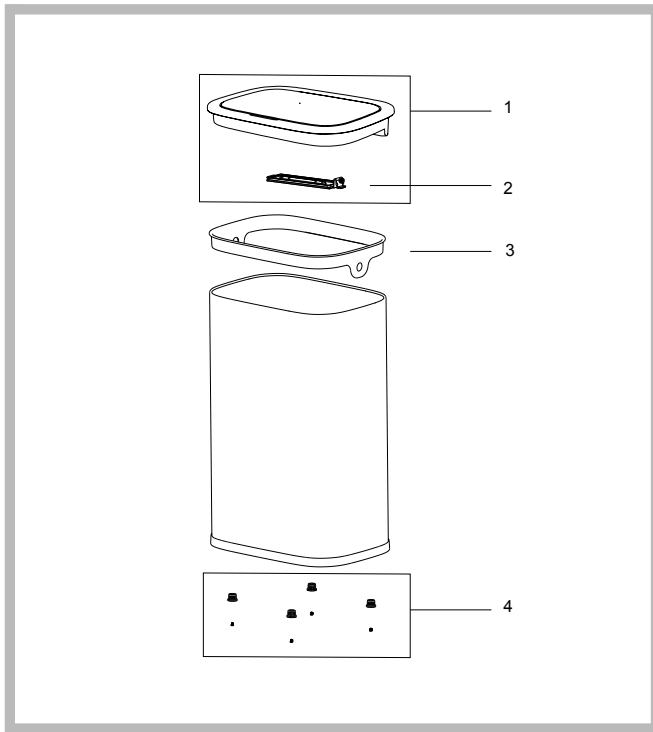

No.	Description	Kraus RP#
1	Sensor Lid	KP77007
2	Battery Box Cover	KP77013
3	Garbage Bag Ring	KP77008
4	Rubber Feet	KP77006

Troubleshooting

If you have followed the instructions carefully and your trash can still does not work properly, take the following corrective steps:

PROBLEM	ACTION
Lid unusually opening	<p>Check whether batteries are installed properly according to "+" and "-" instruction.</p> <p>Check whether the sensing area is clean or not, please use a clean cloth to wipe it if it is dirty.</p>
Lid unusually closing	<p>Check whether the sensing area is clean or not, please use a clean cloth to wipe it if it is dirty.</p> <p>Check whether electric circuits are damp. If yes, please do not connect the power source. You can only use the bin if it is dry.</p> <p>Check whether there is any obstruction around the lid. If yes, please remove it.</p>
Low Battery	Lid opens slowly and the indicator light turns red, replace the batteries.

NOTE: If these solutions do not work, please contact customer service at 1-800-775-0703. Do not attempt to repair the trash bin by yourself.

Accessories - Limited Warranty

Kraus® USA Plumbing, LLC ("Kraus") extends this warranty to the original purchaser for personal household use of the Accessories when purchased from an authorized Kraus dealer and in the location of original installation. This warranty is non-transferable.

Kraus warrants the structure and finish of the Accessories to be free from defects in material and workmanship under normal usage for a period of one (1) year from the date of purchase.

Any product reported to the authorized dealer or to Kraus as being defective within the warranty period will be repaired or replaced with a product of equal value at the option of Kraus.

Commercial Warranty

Kraus USA Plumbing, LLC ("Kraus") warrants its Products for a period of one (1) year to commercial purchasers of Products used in industrial, commercial and business applications.

Care and Cleaning Instructions

Certain cleaning products may cause damage to a Product's finish and use of the following on the Product will void this warranty:

- Abrasive cleaners such as powders, bleach, ammonia, alcohol or chlorine
- Abrasive pads, steel wool or wire brushes

What is Not Covered

This warranty does not cover Products that were discontinued when purchased or display Products, whether such Products were purchased at discount outlets, unauthorized dealers, and/or sold on clearance. This warranty does not cover any free gifts included with purchase.

This warranty does not cover damage resulting from neglect, misuse (including use for an unintended application), abuse, carelessness, accident, hard water or mineral deposits, exposure to corrosive materials, improper maintenance, alteration of the Product, or failure to follow care, cleaning or installation instructions enclosed with your Product. Kraus recommends that all Kraus Products be installed by a fully licensed and insured trade professional with experience in the installation of bathroom and/or kitchen manufactured goods.

How to Make a Warranty Claim

If you are a **consumer purchaser**, please contact a Kraus® Customer Service Representative at:

Kraus USA Plumbing, LLC
12 Harbor Park Drive
Port Washington, NY 11050
Toll-free 800-775-0703
Customerservice@kraususa.com

If you are a **plumbing contractor or trade professional**, please contact a Kraus Pro Representative at:

Kraus USA Plumbing, LLC
12 Harbor Park Drive
Port Washington, NY 11050
516-801-8955
Proservice@kraususa.com

If you are an **authorized partner**, please contact a Partner Support Representative at:

Kraus USA Plumbing, LLC
12 Harbor Park Drive
Port Washington, NY 11050
516-801-8954
Partnersupport@kraususa.com

In requesting warranty service, please be ready to provide your proof of purchase and a description of the problem. Shipping charges will be covered for the first (1) year of the warranted replacement part or product (HI, AK, and Puerto Rico shipping charges may apply). International shipping fees are not included.

Limitation on Duration of Implied Warranties

Please note that some states/provinces (including Quebec) do not allow limitations on how long an implied warranty lasts, so the below limitations may not apply to you. TO THE MAXIMUM EXTENT PERMITTED BY APPLICABLE LAW, ANY IMPLIED WARRANTY, INCLUDING THE IMPLIED WARRANTIES OF MERCHANTABILITY AND OF FITNESS FOR A PARTICULAR PURPOSE, IS LIMITED TO THE STATUTORY PERIOD OR THE DURATION OF THIS WARRANTY, WHICHEVER IS SHORTER.

Limitation of Special, Incidental or Consequential Damages

Please note that some states/provinces (including Quebec) do not allow the exclusion or limitation of special, incidental or consequential damages, so the below limitations and exclusions may not apply to you. TO THE MAXIMUM EXTENT PERMITTED BY APPLICABLE LAW, THIS WARRANTY DOES NOT COVER, AND KRAUS USA PLUMBING, LLC SHALL NOT BE LIABLE FOR, ANY SPECIAL, INCIDENTAL OR CONSEQUENTIAL DAMAGES (INCLUDING LABOR CHARGES TO REPAIR, REPLACE, INSTALL OR REMOVE THIS PRODUCT), WHETHER ARISING OUT OF BREACH OF ANY EXPRESS OR IMPLIED WARRANTY, BREACH OF CONTRACT, TORT, OR OTHERWISE.

This warranty gives you specific legal rights, and you may also have other rights which vary from state/province to state/province.

IMPORTANT

Register Your Kraus Product

Activate Your Warranty

Access Premium Customer Support

Get Product Information

REGISTER TODAY

<http://www.kraususa.com/registration>



Kräus[®]
www.kraususa.com