

HEKMAN®

A HOWARD MILLER COMPANY
Grand Rapids, Michigan

INSTALLATION INSTRUCTIONS

Pattern Description 25224/25424 is the arm chair

DO NOT SCALE SKETCHES









COPYRIGHT 1997 HEKMAN FURNITURE COMPANY

Pattern Number(s)

25224/25424

Drawn By INY

Date 10/14/20

PARTS			Q' TY
A		5/16*1-1/2"	1
B		5/16*3-1/4"	4
C		5/16 "	9
D		5/16 "	9
E		5/16 "	4
F		13MM	1
G		5MM	1
H		8*1-1/2"	2

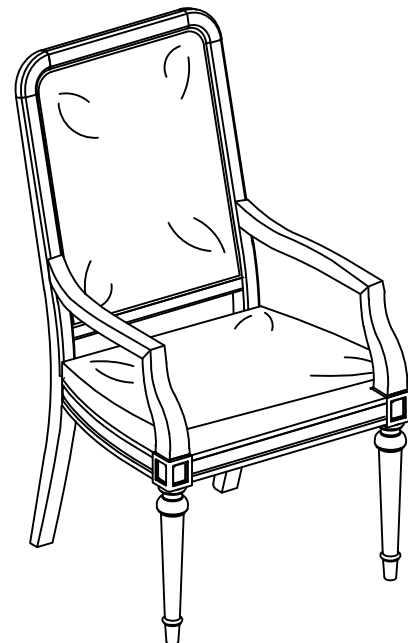
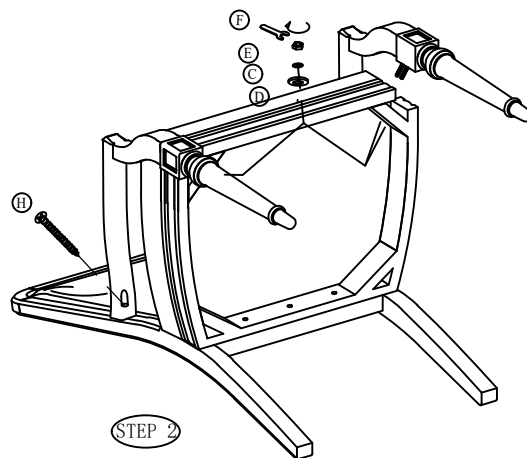
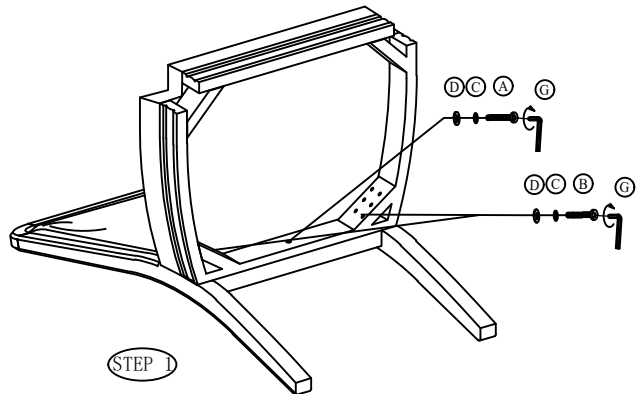

TO ASSEMBLE: (Two people required)

Step 1: Place the Chair Back on a padded surface, and assemble the Chair Seat frame to the Chair Back (as shown in Step 1), using one short bolts (A) and four long bolts (B) with five lock washers (C) and five flat washers (D) tighten with the wrench (G). Do not fully tighten any bolts until after chair has been completely assembled.

Step 2: Attach both front legs to the seat frame using four nuts (E), and four lock washers (C) and four flat washer (D) Tighten with the wrench (F).

Attach the top of the arms to the back of the chair using wood screw (H).

STEP 3