



Manufactured by:
Backyard Discovery
3305 Airport Drive, Pittsburg, KS
66762 800-856-4445

Basepoint Business Centre: Rivermead Drive, Westlea, Swindon SN5 7EX Phone: 0800-118-2476
J.P. Coenstraat 7, The Bridge, The Hague, 2595 WP, Netherlands Phone: 08005678990

GRANADA GAZEBO WITH BAR

MODEL # : 2206090B



Please visit www.backyarddiscovery.com
For the most up to date assembly manual, to register your product, or to order replacement parts *Para obtener instrucciones en español, visite* www.backyarddiscovery.com



EASY STEP-BY-STEP
3D INTERACTIVE INSTRUCTIONS
DOWNLOAD THE FREE APP



OWNER'S MANUAL - BASIC SETUP DIMENSIONS & ASSEMBLY NOTES

It is critically important that you start with square and level footings, concrete pad or deck to attach your structure

- Pay close attention to the items needed for each step. Make sure you are using the correct hardware for each step. Using incorrect hardware may result in improper assembly
- Remember to double check for underground utilities and overhead electrical lines

Post mounts are provided with your structure which allows you to permanently install your structure to a pre-existing or new wood or concrete surface. See Anchor Instructions for further details and recommendations.

- The hardware to attach the post mounts to the structure is included.
- The hardware to mount the structure permanently to a concrete surface is included.
- The hardware to mount the structure permanently to a wood deck is NOT included and will need to be purchased separately. You must ensure there is ample structural support under the deck before permanently attaching.

BELOW MEASUREMENTS BASED ON ANGLE TABLE CONFIGURATION, STANDARD BAR HEIGHT

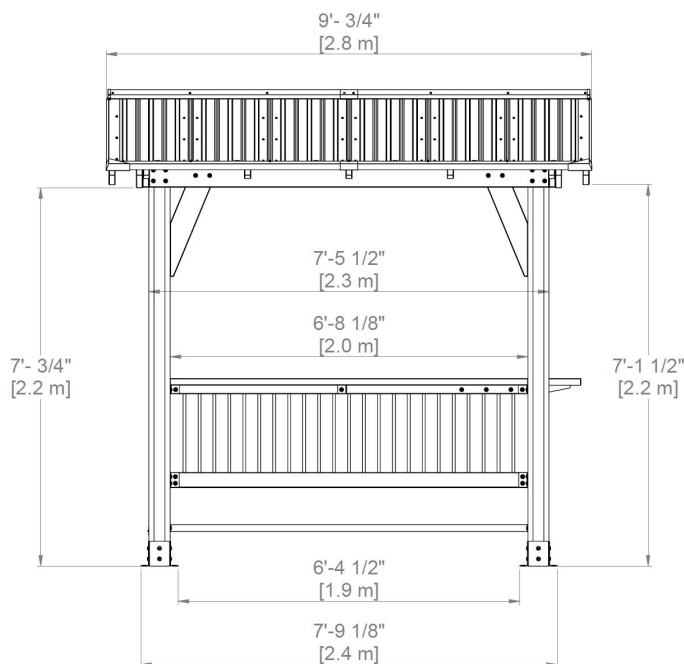
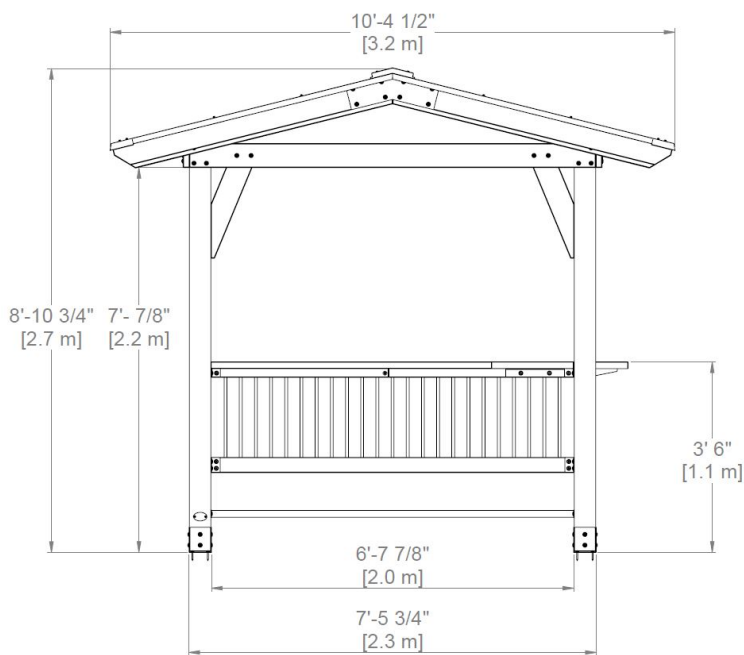
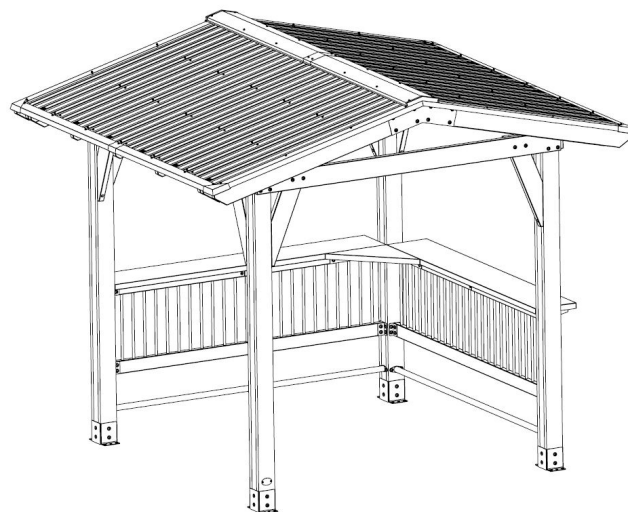
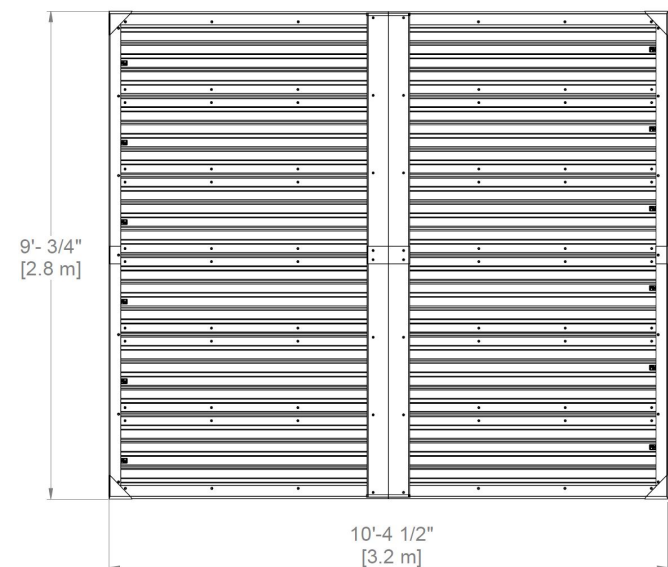

OWNER'S MANUAL - ANCHORING LAYOUT

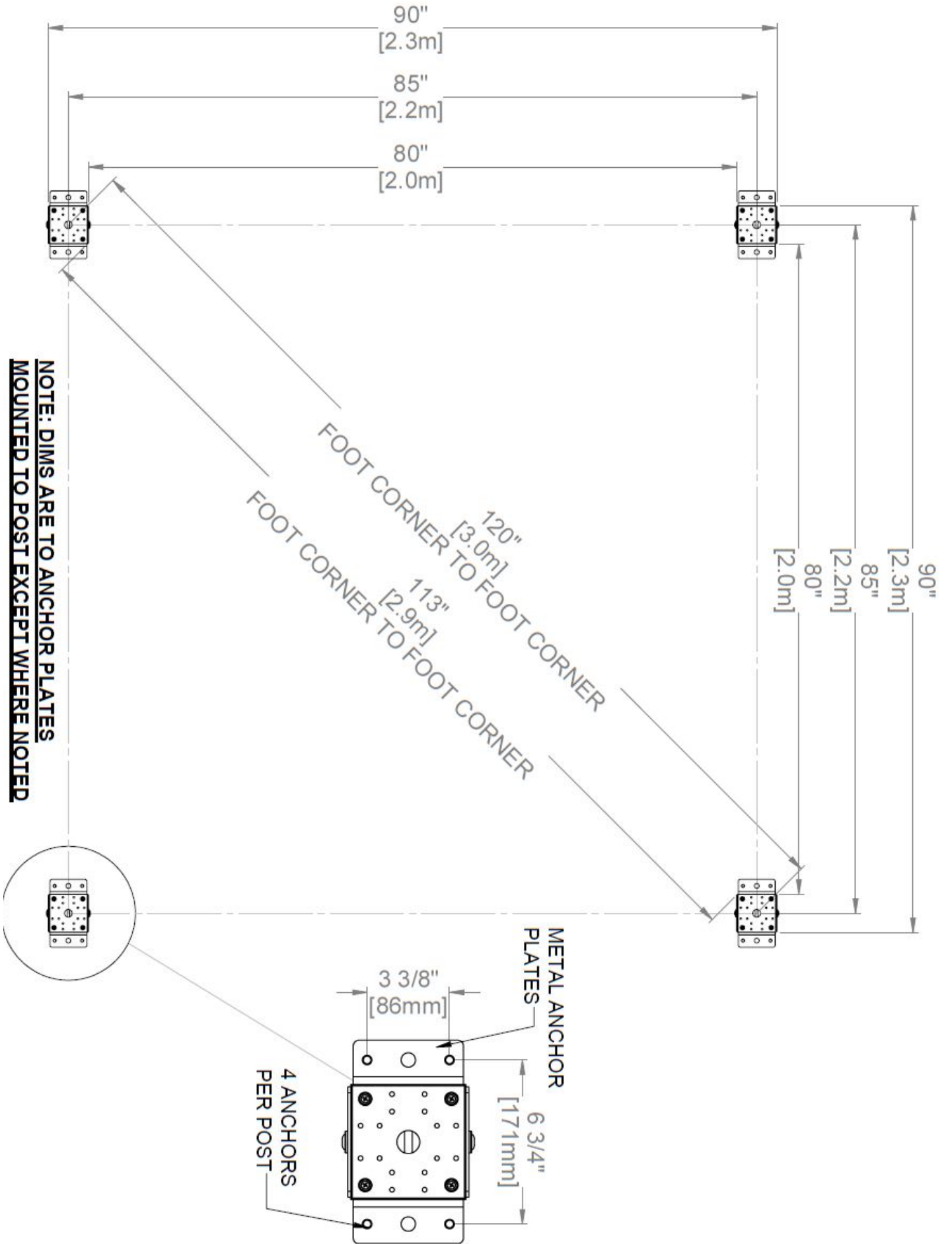

OWNER'S MANUAL - PARTS IDENTIFICATION

Wood Components (Not to Scale)



D1 | BEAM-W4L16358
(x2) | 1 7/16"x5 1/4"x89 1/2" (36x134x2274)



D2 | BEAM-W4L16359
(x2) | 1 7/16"x5 1/4"x89 1/2" (36x134x2274)



D3 | CORBEL-W4L16360
(x7) | 1 7/16"x5 1/4"x27 1/2" (36x134x699)

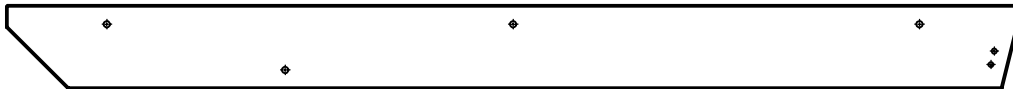

D4 | RAFTER-W4L16361
(x4) | 1 7/16"x5 1/4"x63 9/16" (36x134x1615)

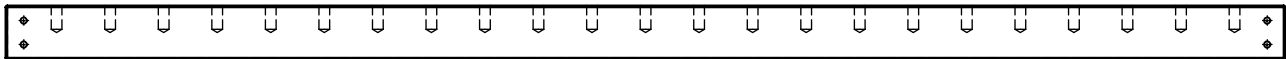

E1 | RAIL-W4L16362
(x2) | 1 7/16"x3 3/8"x80" (36x86x2032)

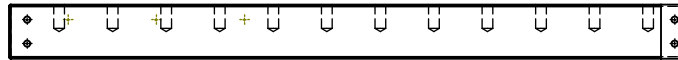

E2 | RAIL-W4L16363
(x2) | 1 7/16"x3 3/8"x42 7/16" (36x86x1078)



E3 | RAIL-W4L16364
(x2) | 1 7/16"x3 3/8"x39 1/8" (36x86x993)



G1 | RIDGE BEAM-W4L16365
(x1) | 15/16"x5 1/4"x29 1/8" (24x134x740)



G2 | RIDGE BEAM-W4L16366
(x1) | 15/16"x5 1/4"x66 3/8" (24x134x1686)

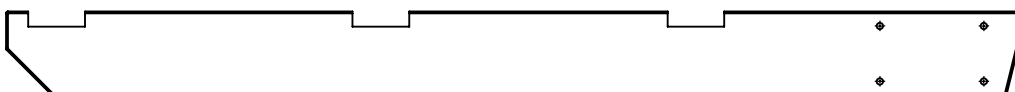

D5 | RAFTER-W4L16367
(x4) | 1 7/16"x5 1/4"x63 13/16" (36x134x1621)

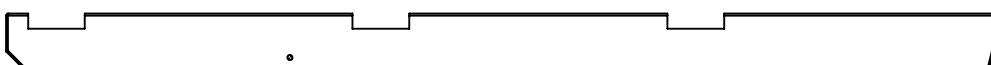

E4 | RAFTER-W4L16368
(x6) | 1 7/16"x3 3/8"x62 5/16" (36x86x1583)

OWNER'S MANUAL - PARTS IDENTIFICATION

Wood Components (Not to Scale)



H1 | PURLIN-W4L16369
(x6) | 15/16"x3 3/8"x32 9/16" (24x86x827)

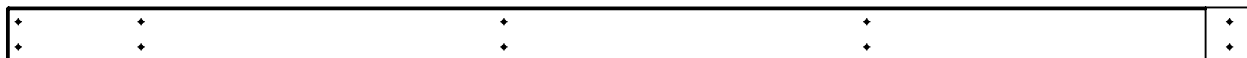

H2 | PURLIN-W4L16370
(x6) | 15/16"x3 3/8"x77 15/16" (24x86x1979)



H3 | RIDGE SUPPORT-W4L16371
(x4) | 15/16"x3 3/8"x47 9/16" (24x86x1208)



E5 | RAFTER-W4L16372
(x4) | 1 7/16"x3 3/8"x62 5/16" (36x86x1583)

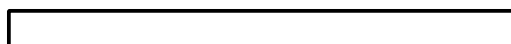

J1 | RIDGE CAP STIFFENER-W4L16373
(x2) | 15/16"x2 3/8"x31 7/8" (24x60x810)

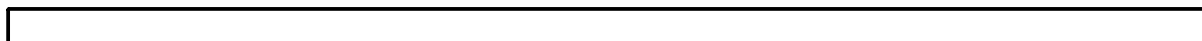

J2 | RIDGE CAP STIFFENER-W4L16374
(x2) | 15/16"x2 3/8"x75 3/8" (24x60x1914)



P1 | POST-W2A03453
(x2) | 4 3/4"x4 3/4"x89 1/2" (120x120x2274)



P2 | POST-W2A03454
(x2) | 4 3/4"x4 3/4"x89 1/2" (120x120x2274)



D6 | CORBEL W/TAG-W2A03459
(x1) | 1 7/16"x5 1/4"x27 1/2" (36x134x699)

OWNER'S MANUAL - PARTS IDENTIFICATION

Hardware Components (Not to Scale)

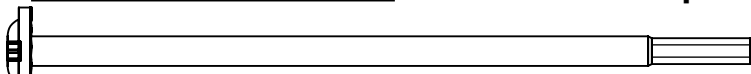

H101046 | BOLT WH BLK
(x4) | 5/16 x 7 1/2

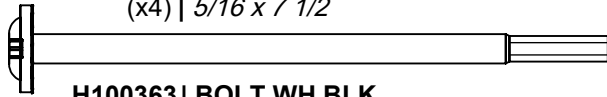

H100363 | BOLT WH BLK
(x30) | 5/16 x 6

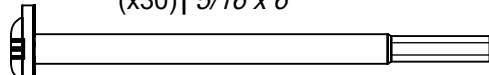

H100480 | BOLT WH BLK
(x9) | 5/16 x 4 3/4

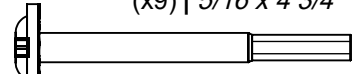

H100484 | BOLT WH BLK
(x7) | 5/16 x 3 1/4

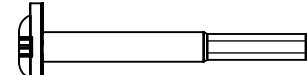

H100195 | BOLT WH BLK
(x30) | 5/16 x 2 3/4

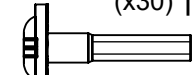

H100407 | BOLT WH BLK
(x22) | 5/16 x 1 1/2

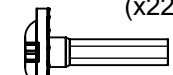

H100459 | BOLT WH BLK
(x22) | 5/16 x 1 1/4

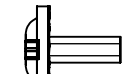

H100663 | BOLT WH BLK
(x1) | 5/16 x 3/4

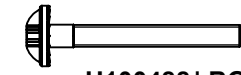

H100488 | BOLT WH BLK
(x15) | 1/4 x 2



H100406 | BOLT WH BLK
(x2) | 1/4 x 1 1/2

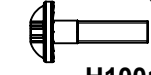

H100171 | BOLT WH BLK
(x4) | 1/4 x 1



H100770 | WASHER FLAT BLK
(x7) | 5/16



H100630 | WASHER FLAT BLK
(x35) | 8 x 19



H100405 | WASHER LOCK EXT BLK
(x17) | 6 x 15



H100198 | WASHER LOCK EXT BLK
(x75) | 12 x 18



H100379 | T-NUT BLK
(x83) | 5/16



H100653 | NUT LOCK BLK
(x18) | 1/4



H100479 | NUT LOCK BLK
(x7) | 5/16



H100469 | NUT BARREL WH BLK
(x30) | 5/16 x 5/8

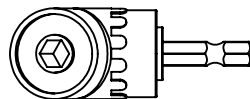

**H101114 | RIGHT ANGLE
(x1) | DRILL ADAPTER**

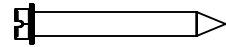

H100120 | SCREW CONCRETE ANCHOR
(x18) | 1/4 x 2

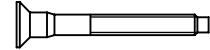

H101030 | SCREW CONFIRMAT BLK
(x22) | 7 x 2



H100391 | SCREW PFH BLK
(x88) | 8 x 2



H100200 | SCREW PFH BLK
(x17) | 8 x 1 1/2



H100395 | SCREW PFH BLK
(x4) | 8 x 3/4



H100536 | SCREW PWH BLK
(x13) | 8 x 1 1/4



H100392 | SCREW PWH BLK
(x19) | 8 x 3/4

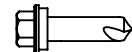

H101116 | SCREW SELF TAPPING BLK
(x24) | 1/4 x 1



H101117 | SCREW WOODGRIP BLK
(x92) | 10 x 3/4



H101097 | LAG SCREW WH BLK
(x9) | 1/4 x 1 3/4



H100471 | LAG SCREW WH BLK
(x18) | 5/16 x 1 1/2

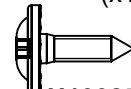

H100854 | LAG SCREW WH BLK
(x42) | 5/16 x 1



H100856 | DRILL BIT
(x1) | 1/4 (6MM)

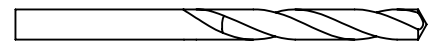

H101108 | DRILL BIT
(x1) | 3/8 (10MM)

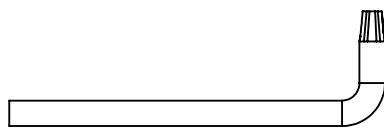

H100114 | TORX WRENCH
(x1) | T-30

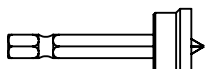

H100764 | SCREW SETTER
(x1)

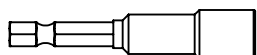

H101106 | HEX DRIVER
(x1) | 5/16



**H101100 | MAGNETIC
(x1) | DRIVER**

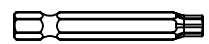

H100147 | TORX BIT
(x1) | T-30

OWNER'S MANUAL - PARTS IDENTIFICATION

Accessory Components (Not to Scale)

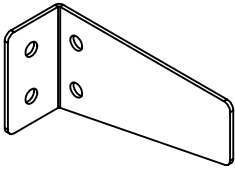

A4M01223
(x4) | L BRACKET

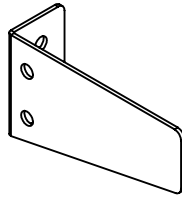

A4M01224
(x2) | L BRACKET



A4M00855 | L BRACKET
(x12) | 55x32x82x3.175



A4M01478
(x8) | POST ANCHORING PLATE

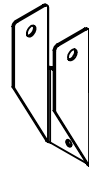

A4M01228
(x6) | RAFTER BRACKET



A4M01477 | POST PLATE
(x8)

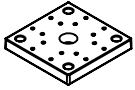

A6P00500
(x4) | PLASTIC POST FOOT

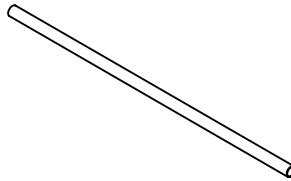

A4M01225
(x46) | METAL TUBE

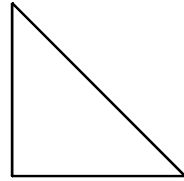

A4M01475 | CORNER TABLE
(x1) (ANGLE CONFIGURATION ONLY)

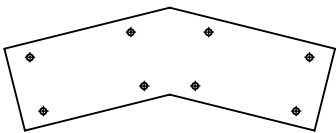

A4M01508
(x2) | GABLE BRACKET

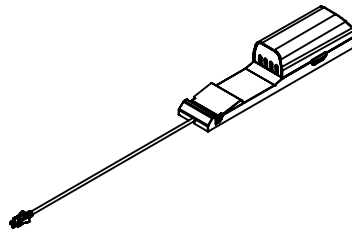

9205413 | ELECTRICAL
(x1) ENCLOSURE

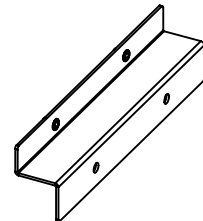

A4M01662 | TABLE BRACKET W/ INSERTS
(x2) | (ANGLE CONFIGURATION ONLY)



A100241 | BYD ID TAG (SMALL) WITHOUT AGES
(x1)

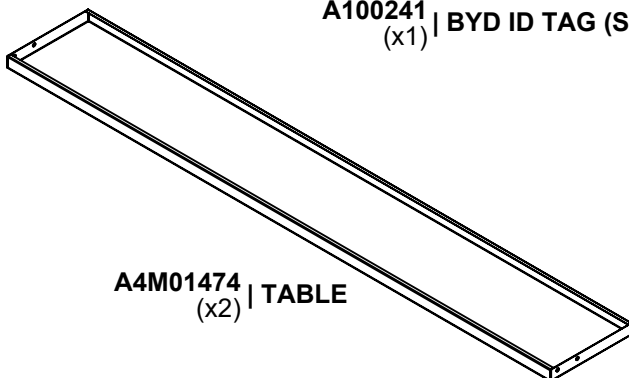

A4M01474
(x2) | TABLE

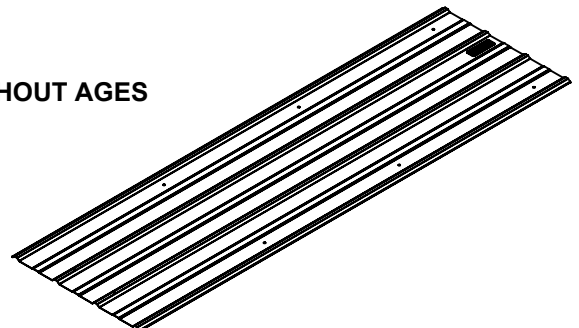

A4M02670 | 29 GA STEEL SHEETING
(x12)

OWNER'S MANUAL - PARTS IDENTIFICATION

Accessory Components (Not to Scale)

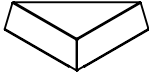

A4M02706
(x4) | CORNER SPLICE TRIM

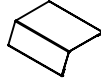

A4M02707
(x2) | ROOF EDGE TRIM SPLICE

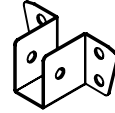

A4M01553
(x2) | RIDGE BRACKET



A6P00513
(x2) | RIDGE CAP PROTECTOR

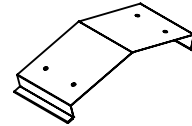

A4M02709
(x1) | RIDGE CAP SPLICE

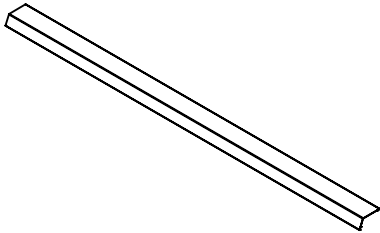

A4M02704
(x4) | ROOF EDGE TRIM

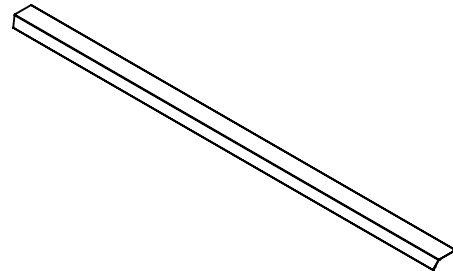

A4M02705
(x4) | ROOF EDGE TRIM

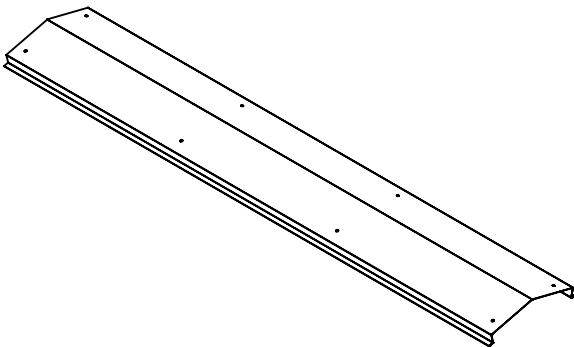

A4M02710
(x2) | RIDGE CAP 29 GA

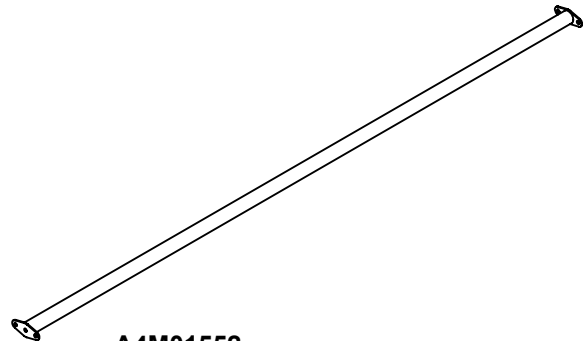

A4M01552
(x2) | FOOT REST RAIL ASSEMBLY

PRE-ASSEMBLY STEP 1 - TOOLS REQUIRED



Cordless Drill
or Electric Drill



Drill
Attachments:
Phillips Head

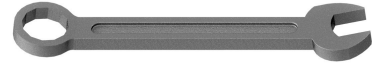

Open End
Wrenches
1/2" & 7/16"

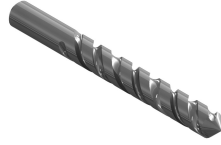

1/8", 3/16", 3/8" &
7/16" Drill Bits



3/8" Drive Ratchet, 1/2" &
7/16" STD Sockets, 1/2" &
7/16" Deep Sockets

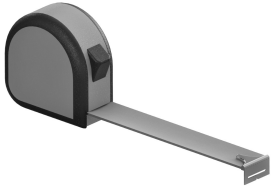

Tape Measure



Claw Hammer



Phillips Screw Driver

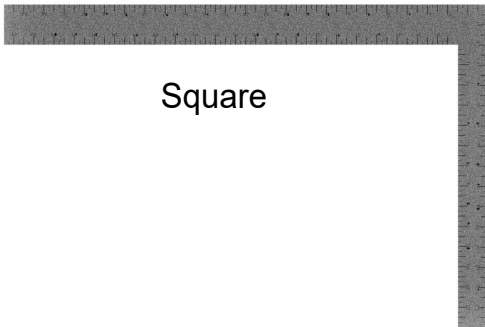

Square



Level 24"

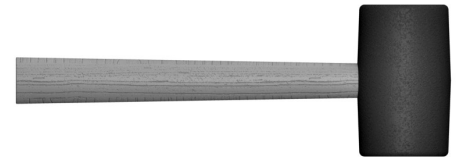

Rubber Mallet
- Optional

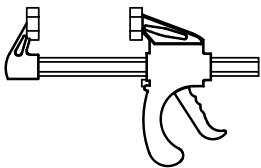

OPTIONAL - QUICK
RELEASE CLAMP

PRE-ASSEMBLY STEP 2 - SORTING PARTS

It is critical for ease of assembly that you take the time to sort and organize the wood and hardware.

WOOD PARTS:

- Organize wood parts by the three-digit, alpha-numeric number stamped on each board (ex. P01).
- If there are multiple boards with the same stamped number, stack those pieces together.
- Stamps can be found on the flat surface of the boards or on the end of the boards.
- Allow yourself plenty of room - the wood pieces can take up a significant amount of space.

NOTE: CARTONS ARE NOT ORGANIZED BY BOARD NUMBER.



HARDWARE PARTS:

- We recommend that you have a separate table to organize the hardware.
- Hardware bags are printed with a seven-digit, alpha-numeric part number.
- You can organize your hardware by part number or group by hardware type (i.e. bolts, nuts, etc.).
- During assembly you only need to reference the last four digits of the number.

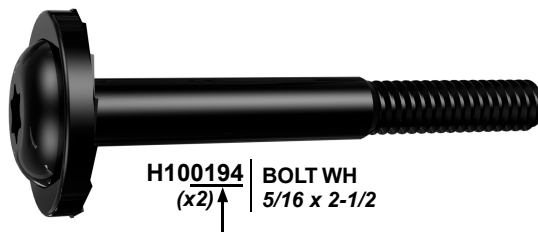

H100194 | BOLT WH
(x2) ↑ 5/16 x 2-1/2

PRE-ASSEMBLY STEP 3 - CHOOSE YOUR ASSEMBLY METHOD

There are several types of assembly instructions available to you.

1. Printed Assembly Manual included with your set
2. BILT APP - 3D interactive instructions
3. Combination of the Printed Manual and BILT APP (Note: Step numbers can differ between the two methods)

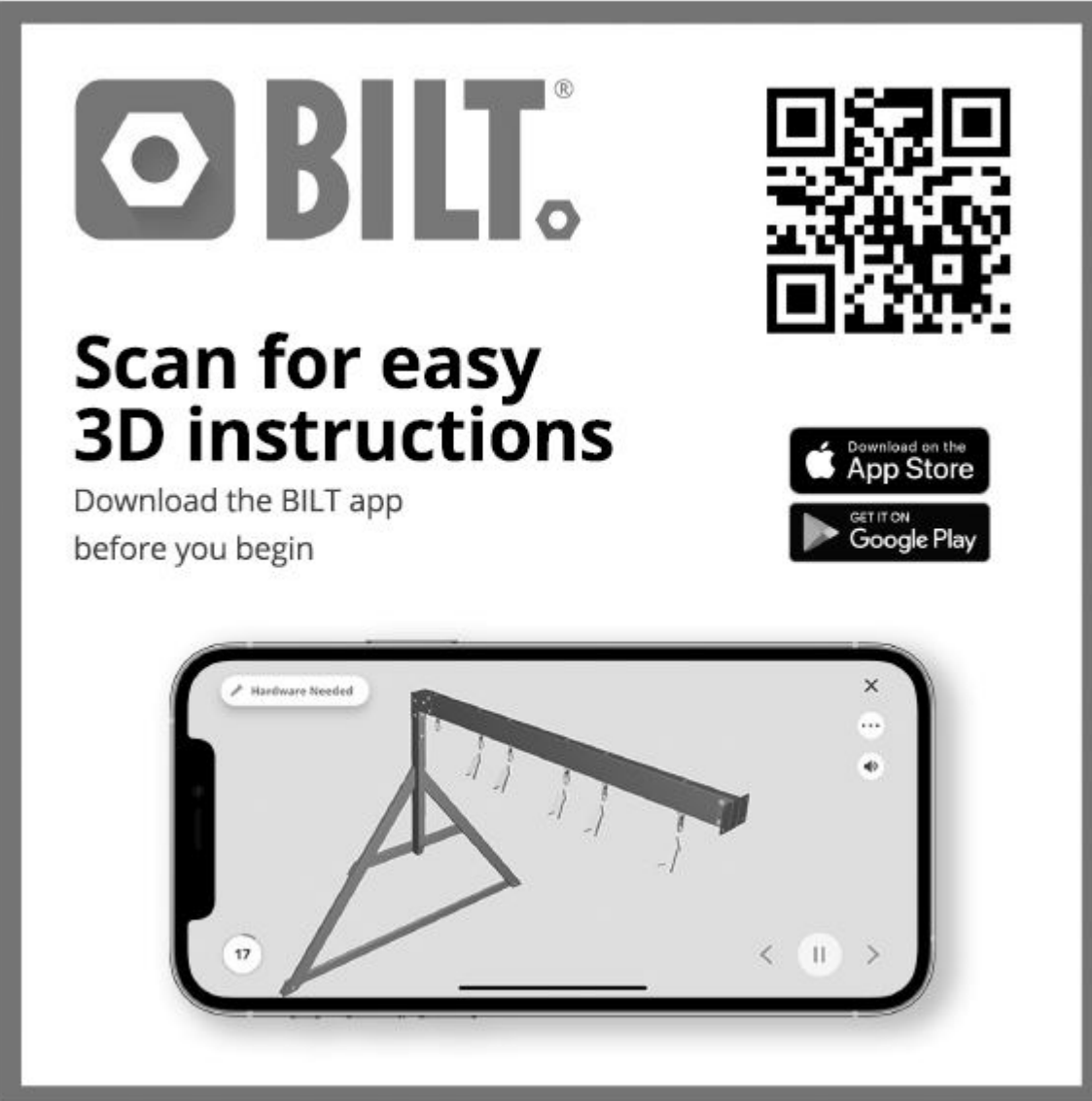

The graphic is a rectangular advertisement for the BILT app. At the top left is the BILT logo, which consists of a hexagonal icon with a white dot inside, followed by the word "BILT." in a bold, sans-serif font with a registered trademark symbol. To the right of the logo is a large QR code. Below the logo and QR code, the text "Scan for easy 3D instructions" is written in a large, bold, black font. Underneath this, in a smaller font, it says "Download the BILT app before you begin". To the right of this text are two buttons: "Download on the App Store" with the Apple logo and "GET IT ON Google Play" with the Google Play logo. At the bottom of the graphic is a smartphone displaying a 3D assembly instruction. The screen shows a grey 3D model of a structure with a horizontal beam and several vertical supports. A "Hardware Needed" label is visible in the top left corner of the app interface. At the bottom of the screen, there is a page number "17" in a circle, a play button, and navigation arrows.

STEP 1 - GAZEBO ASSEMBLY

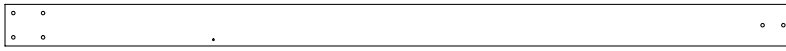

P1 | POST-W2A03453
(x2) | 4 3/4"x4 3/4"x89 1/2" (120x120x2274)



P2 | POST-W2A03454
(x2) | 4 3/4"x4 3/4"x89 1/2" (120x120x2274)

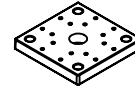

A6P00500
(x4) | **PLASTIC POST FOOT**

QTY	PART NUMBER	DESCRIPTION
16	H100200	SCREW PFH 8x1 1/2 BLK

COMPLETE THIS STEP TWICE

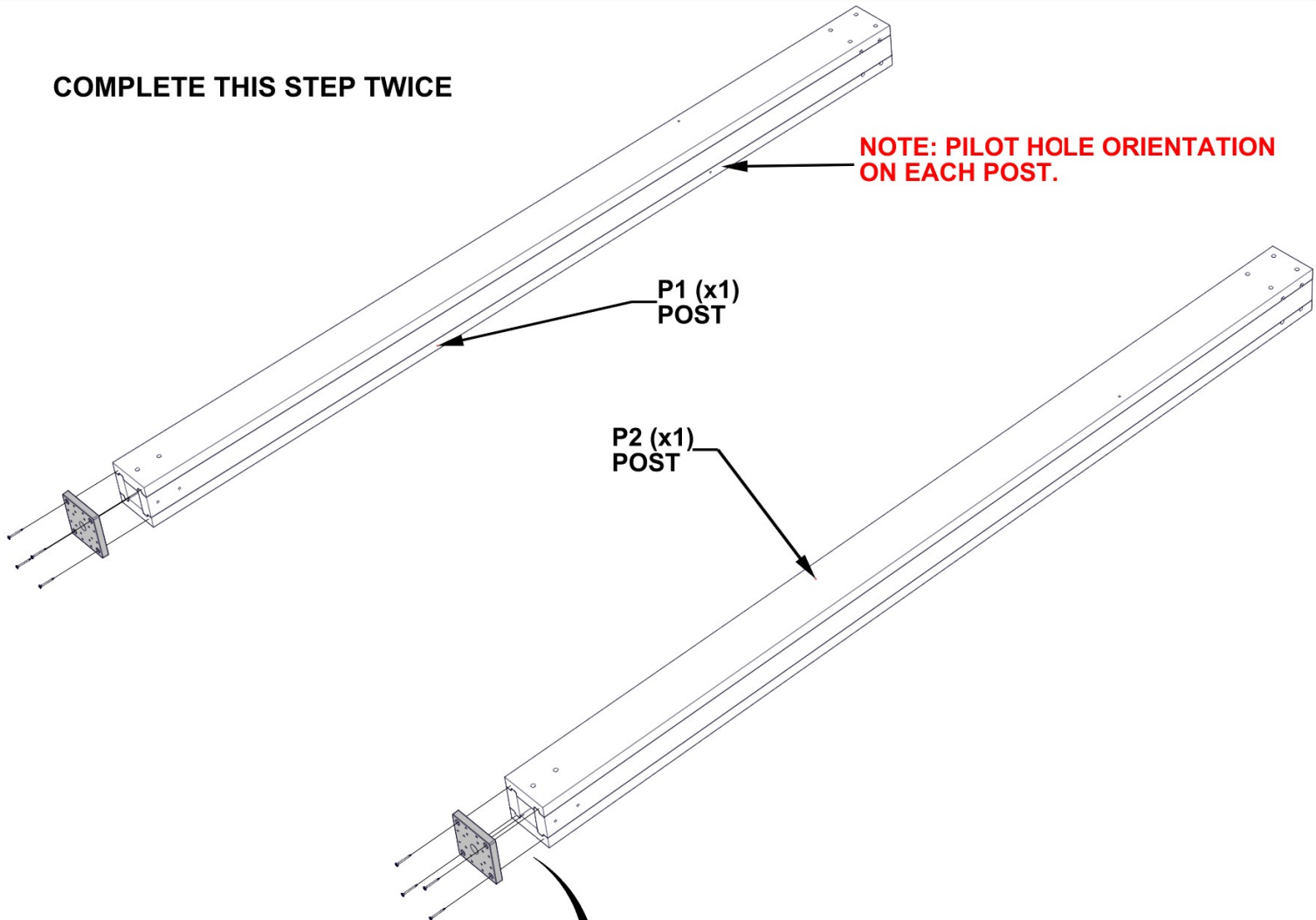

200 (x8) SCREW - 1 1/2"

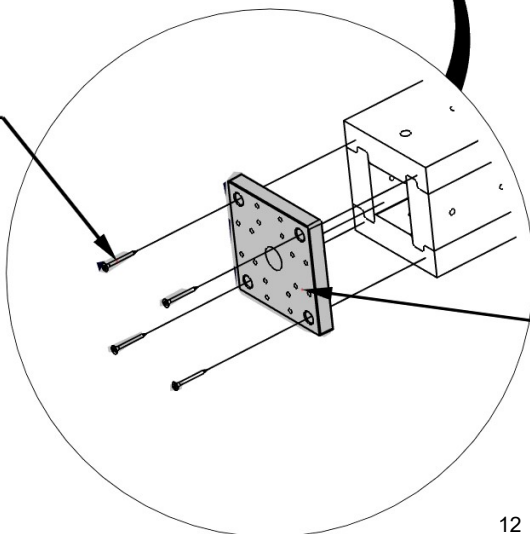

500 (x2) PLASTIC POST FOOT

STEP 2 - GAZEBO ASSEMBLY



D2 | BEAM-W4L16359
(x2) | 1 7/16"x5 1/4"x89 1/2" (36x134x2274)

QTY	PART NUMBER	DESCRIPTION
12	H100363	BOLT WH 5/16x6 BLK
12	H100198	WASHER LOCK EXT 8x19
28	H100379	T-NUT 5/16 BLK

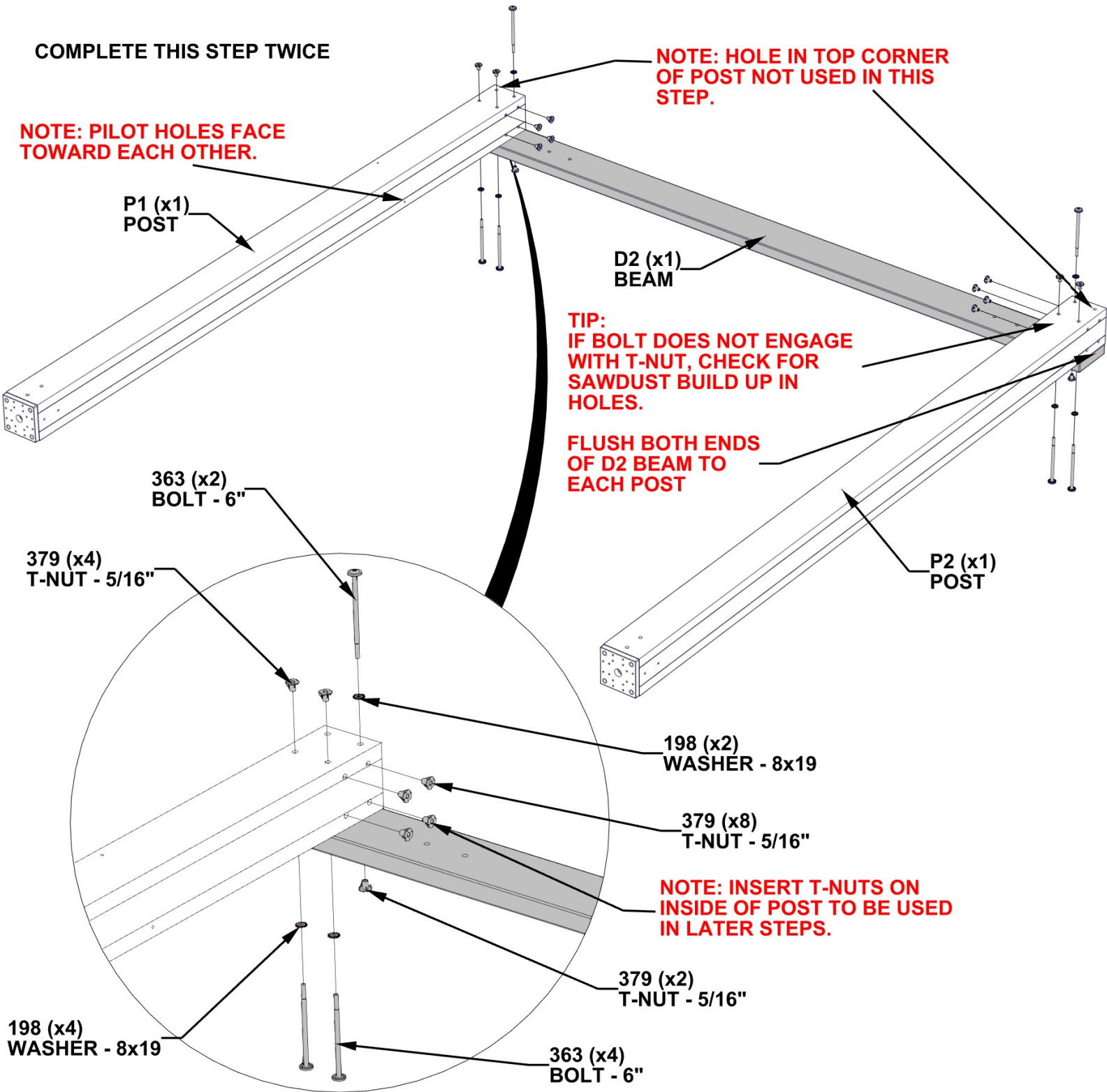

STEP 3 - GAZEBO ASSEMBLY



D3 | CORBEL-W4L16360
(x4) | 1 7/16"x5 1/4"x27 1/2" (36x134x699)

QTY	PART NUMBER	DESCRIPTION
4	H101097	LAG SCREW WH 1/4x1 3/4 BLK
4	H100405	WASHER LOCK EXT 6x15
8	H100379	T-NUT 5/16 BLK
8	H100195	BOLT WH 5/16x2 3/4 BLK
8	H100198	WASHER LOCK EXT 8x19

COMPLETE THIS STEP TWICE.

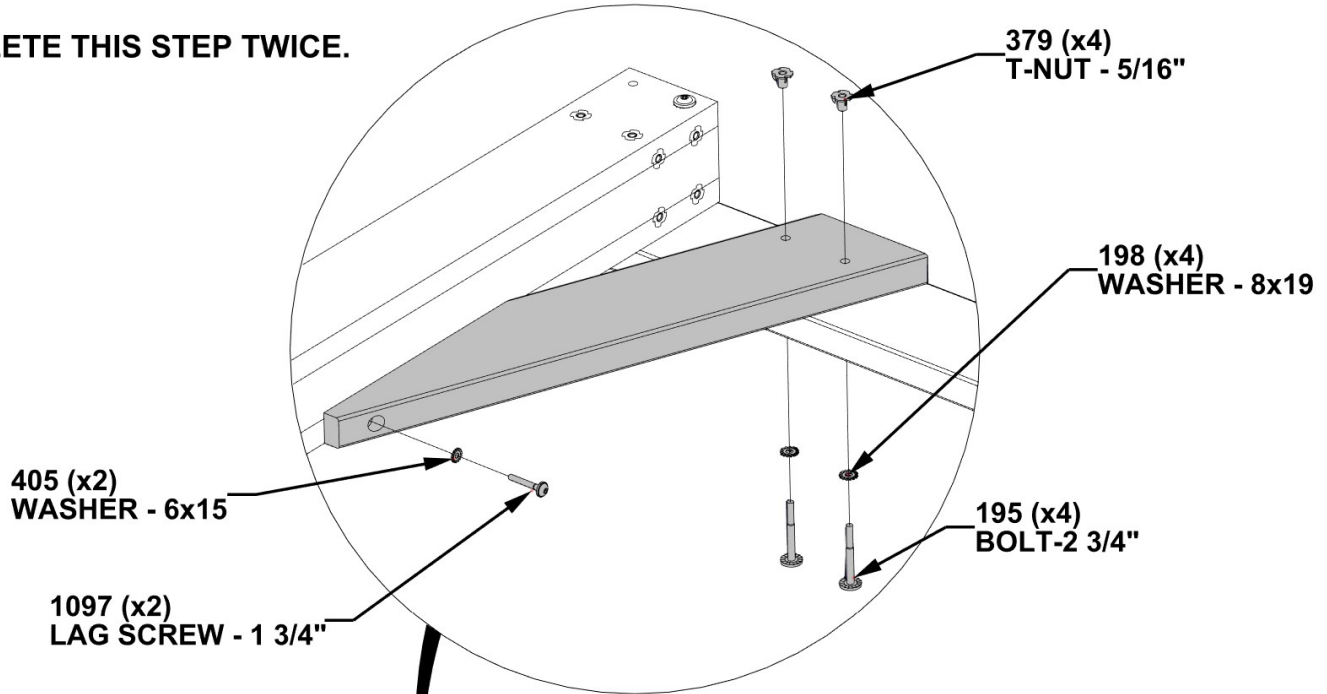

NOTE: ALIGN CORBEL WITH PILOT HOLES IN POST.

NOTE: SQUARE BEAM AND POST AS NEEDED.

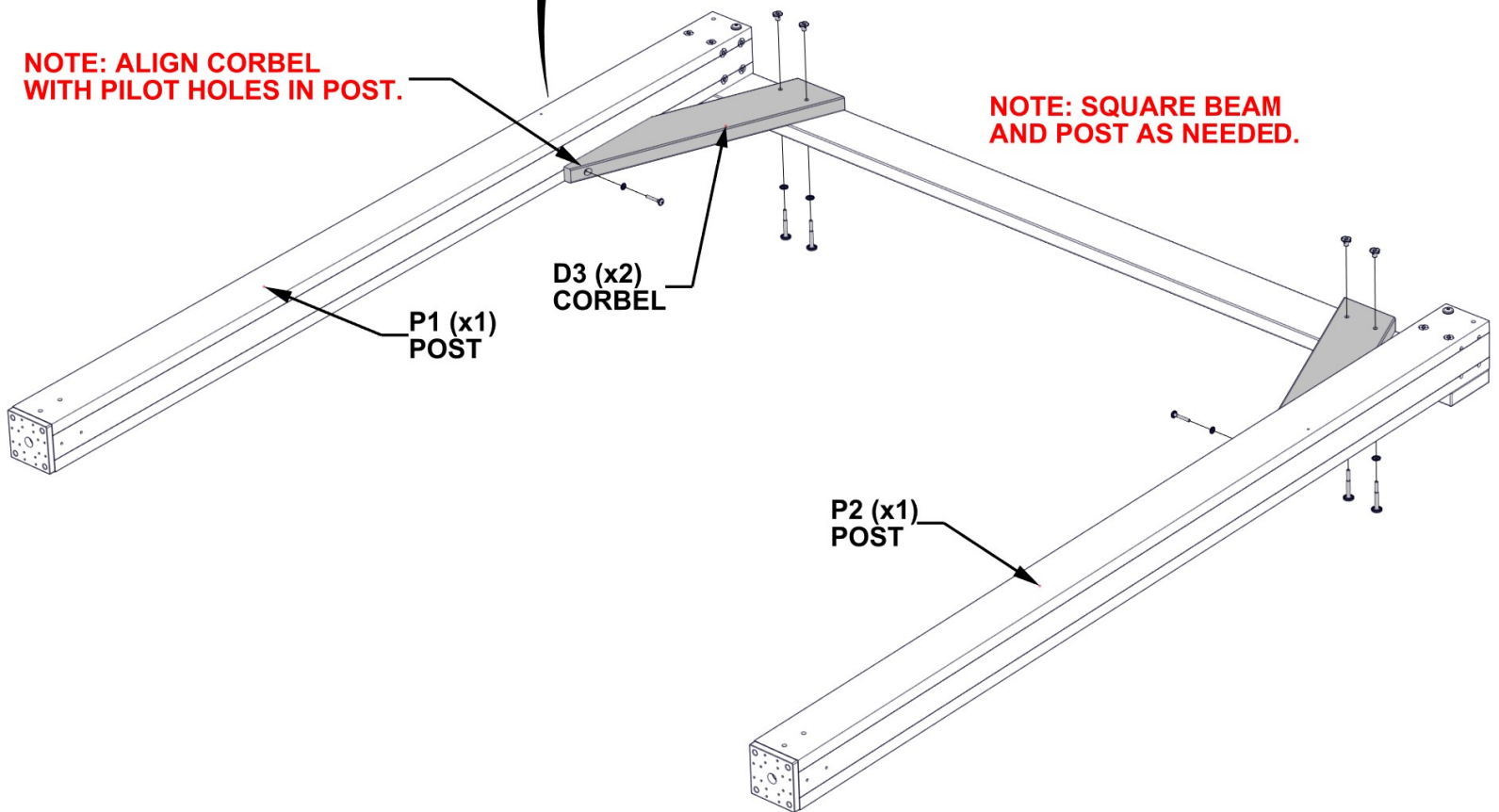

STEP 4 - GAZEBO ASSEMBLY



D3 | CORBEL-W4L16360
(x1) | 1 7/16"x5 1/4"x27 1/2" (36x134x699)



D6 | CORBEL W/TAG-W2A03459
(x1) | 1 7/16"x5 1/4"x27 1/2" (36x134x699)

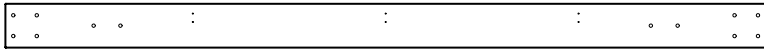

D1 | BEAM-W4L16358
(x1) | 1 7/16"x5 1/4"x89 1/2" (36x134x2274)

QTY	PART NUMBER	DESCRIPTION
4	H100379	T-NUT 5/16 BLK
4	H100195	BOLT WH 5/16x2 3/4 BLK
4	H100198	WASHER LOCK EXT 8x19

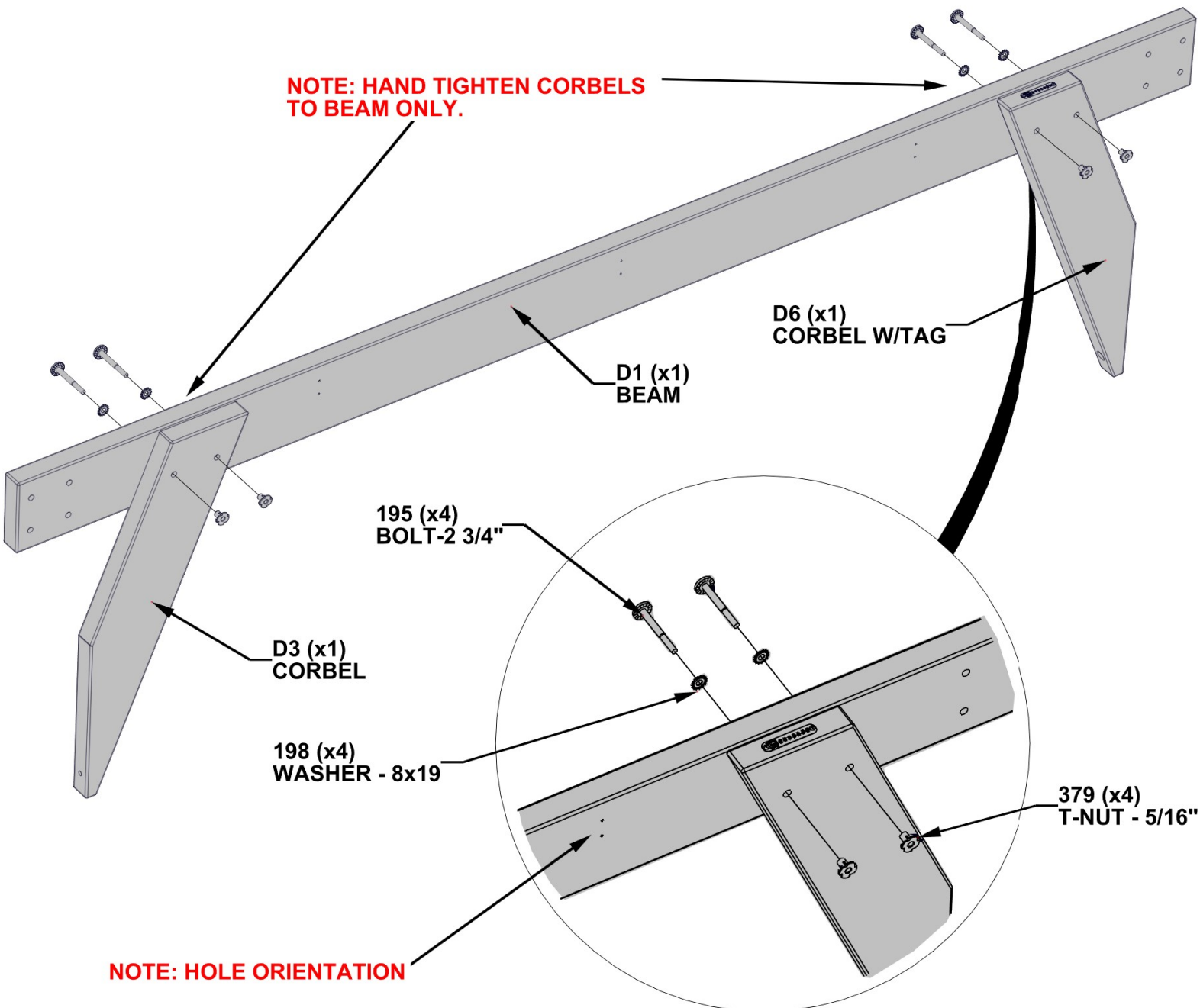

STEP 5 - GAZEBO ASSEMBLY

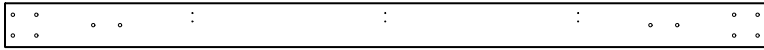

D1 | BEAM-W4L16358
 (x1) | 1 7/16"x5 1/4"x89 1/2" (36x134x2274)

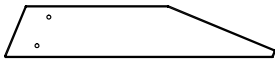

D3 | CORBEL-W4L16360
 (x2) | 1 7/16"x5 1/4"x27 11/16" (36x134x699)

QTY	PART NUMBER	DESCRIPTION
4	H100379	T-NUT 5/16 BLK
4	H100195	BOLT WH 5/16x2 3/4 BLK
4	H100198	WASHER LOCK EXT 8x19

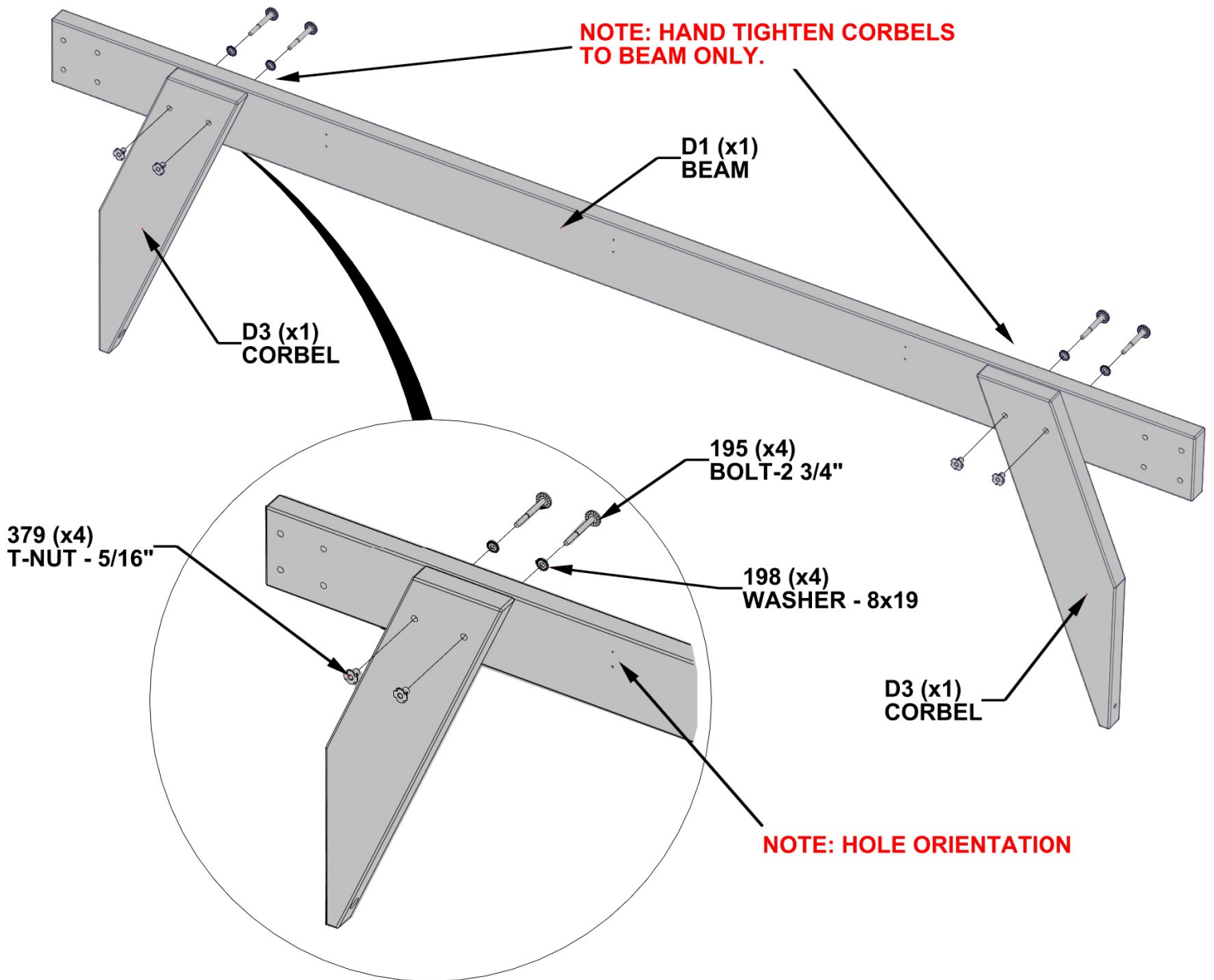

STEP 6 - GAZEBO ASSEMBLY

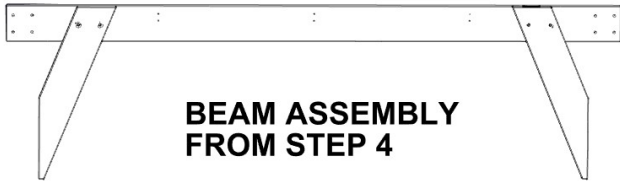

**BEAM ASSEMBLY
FROM STEP 4**

QTY	PART NUMBER	DESCRIPTION
2	H101097	LAG SCREW WH 1/4x1 3/4 BLK
2	H100405	WASHER LOCK EXT 6x15
8	H100363	BOLT WH 5/16x6 BLK
8	H100198	WASHER LOCK EXT 8x19

NOTE: ALIGN BEAM ASSEMBLY FROM STEP 4, WITH HOLES IN POST. SQUARE AS NEEDED BEFORE TIGHTENING ALL FASTENERS FROM PREVIOUS STEP.

TIP: IF BOLT DOES NOT ENGAGE WITH T-NUT, CHECK FOR SAWDUST BUILD UP IN HOLES.

**BEAM ASSEMBLY
FROM STEP 4**

**405 (x2)
WASHER - 6x15**

**1097 (x2)
LAG SCREW - 1 3/4"**

**363 (x8)
BOLT - 6"**

**198 (x8)
WASHER - 8x19**

NOTE: T-NUTS FROM STEP 2.

STEP 7 - GAZEBO ASSEMBLY

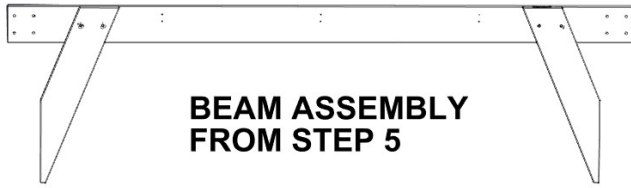

QTY	PART NUMBER	DESCRIPTION
2	H101097	LAG SCREW WH 1/4x1 3/4 BLK
2	H100405	WASHER LOCK EXT 6x15
8	H100363	BOLT WH 5/16x6 BLK
8	H100198	WASHER LOCK EXT 8x19

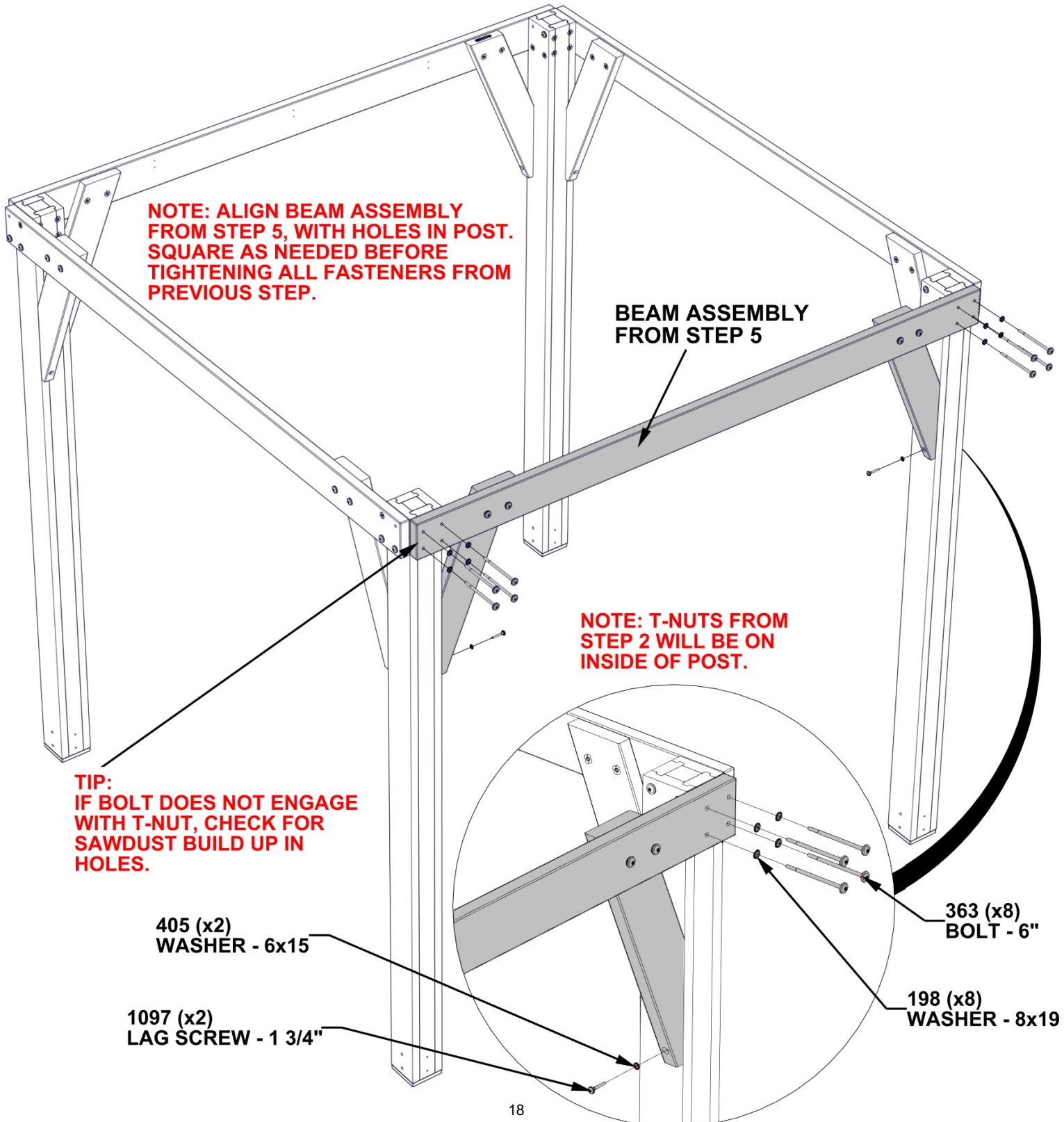

STEP 8 - GAZEBO ASSEMBLY

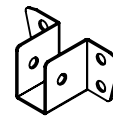

A4M01553
(x2) | RIDGE BRACKET

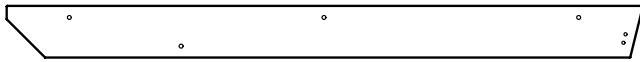

D4 | RAFTER-W4L16361
(x4) | 1 7/16"x5 1/4"x63 9/16" (36x134x1615)

QTY	PART NUMBER	DESCRIPTION
8	H100653	NUT LOCK 1/4 BLK
8	H100405	WASHER LOCK EXT 6x15
8	H100630	WASHER FLAT 8x19 BLK
8	H100488	BOLT WH 1/4x2 BLK
12	H100379	T-NUT 5/16" BLK

COMPLETE THIS STEP TWICE.

INSERT T-NUT INTO RAFTERS.
THESE CONNECTIONS WILL BE USED
WHEN ATTACHING ROOF PANELS.

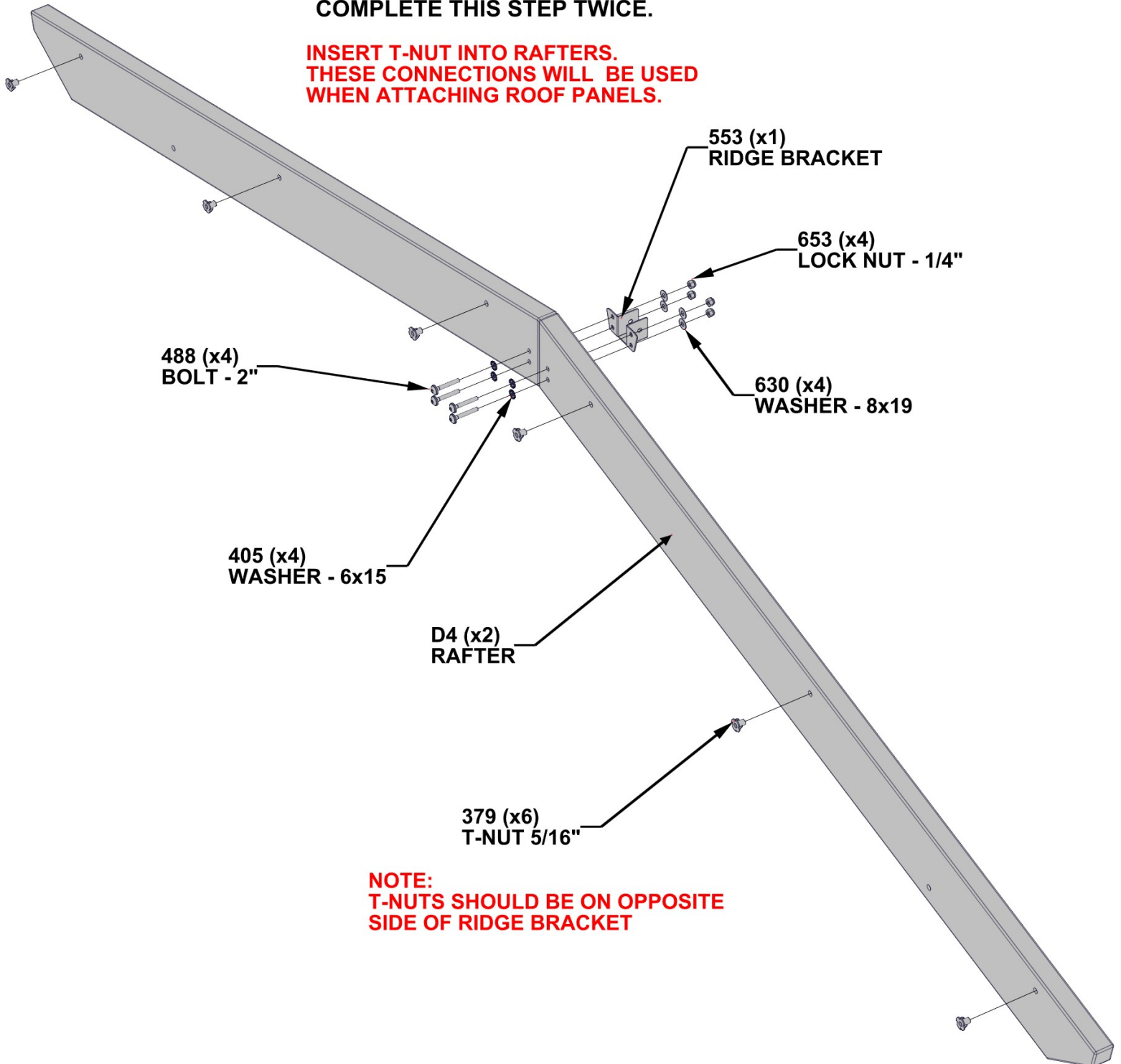

NOTE:
T-NUTS SHOULD BE ON OPPOSITE
SIDE OF RIDGE BRACKET

STEP 9 - GAZEBO ASSEMBLY

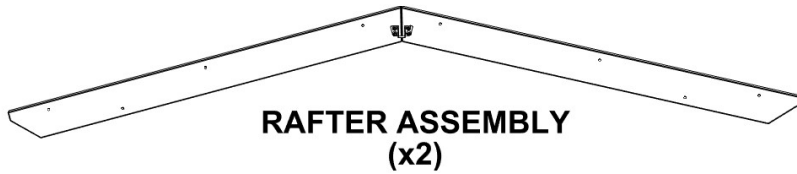

QTY	PART NUMBER	DESCRIPTION
4	H100379	T-NUT 5/16 BLK
4	H101046	BOLT WH 5/16x7 1/2 BLK
4	H100198	WASHER LOCK EXT 8x19

NOTE: ALIGN RAFTER ASSEMBLY FROM PREVIOUS STEP, WITH HOLES IN POST. REPEAT FOR BOTH SIDES.

TIP: IF BOLT DOES NOT ENGAGE WITH T-NUT, CHECK FOR SAWDUST BUILD UP IN HOLES.

**1046 (x4)
BOLT - 7 1/2"**

**379 (x4)
T-NUT - 5/16"**

**198 (x4)
WASHER - 8x19**

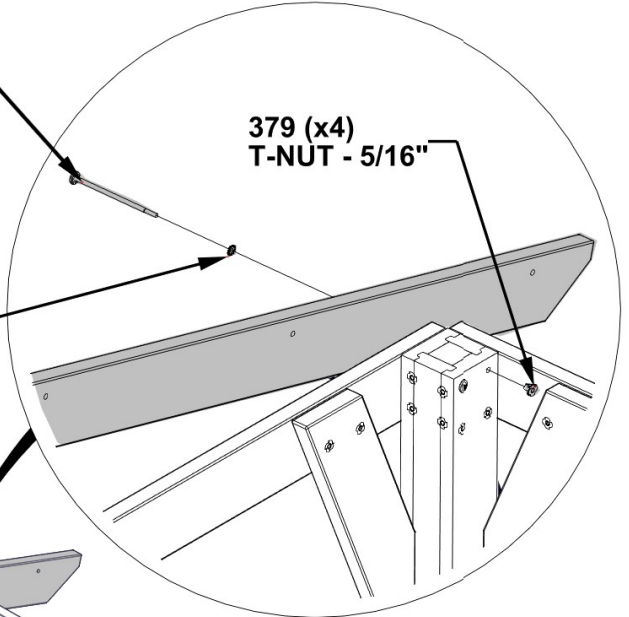

NOTE: ENSURE RIDGE BRACKETS FACE EACH OTHER

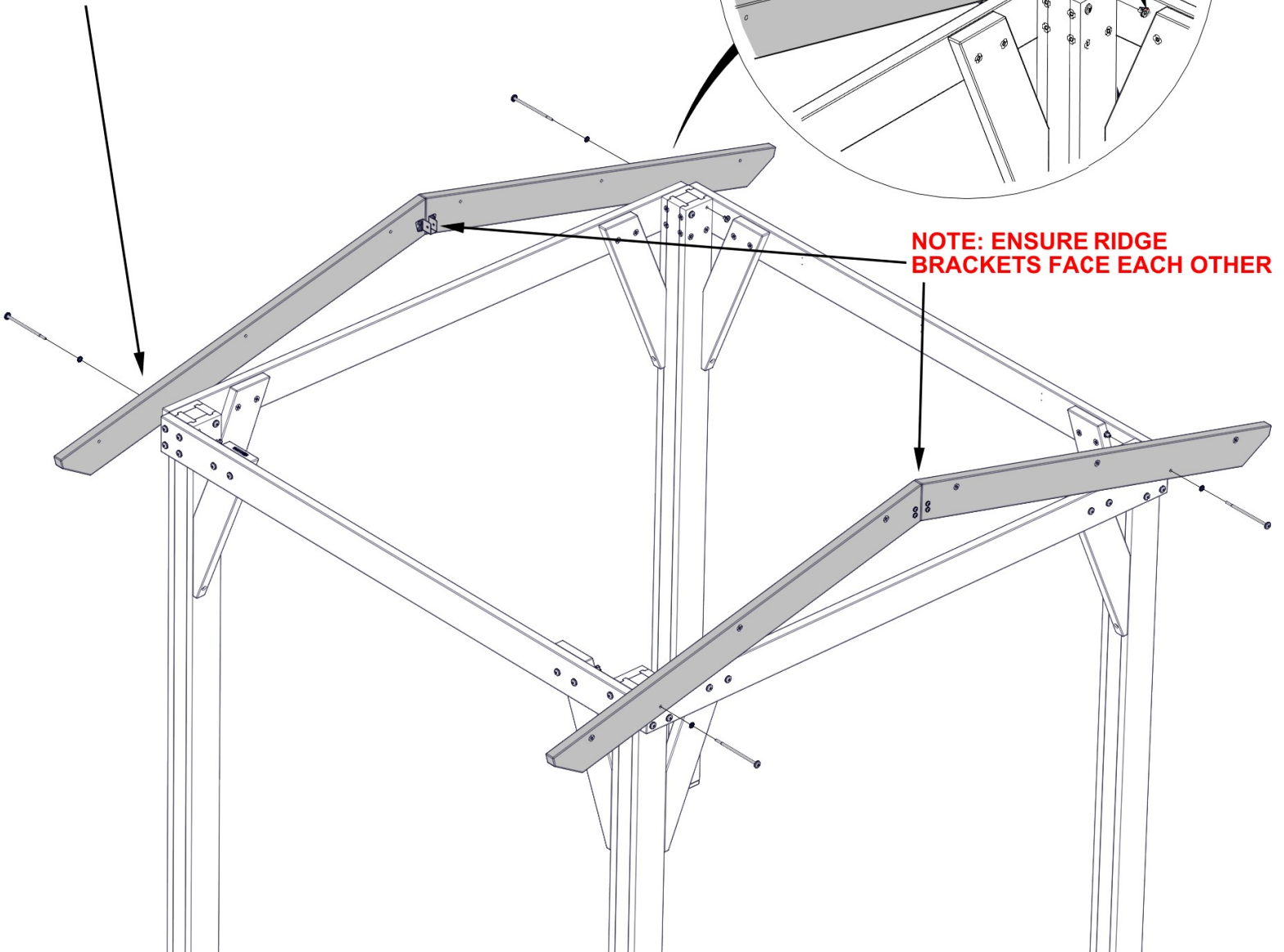

STEP 10 - GAZEBO ASSEMBLY

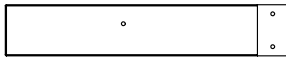

G1 | RIDGE BEAM-W4L16365
(x1) | 15/16"x5 1/4"x29 1/8" (24x134x740)

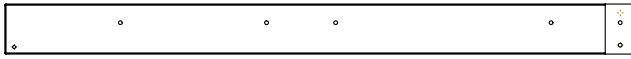

G2 | RIDGE BEAM-W4L16366
(x1) | 15/16"x5 1/4"x66 3/8" (24x134x1686)

QTY	PART NUMBER	DESCRIPTION
1	H100379	T-NUT 5/16 BLK
1	H100663	BOLT WH 5/16x3/4 BLK
1	H100198	WASHER LOCK EXT 8x19

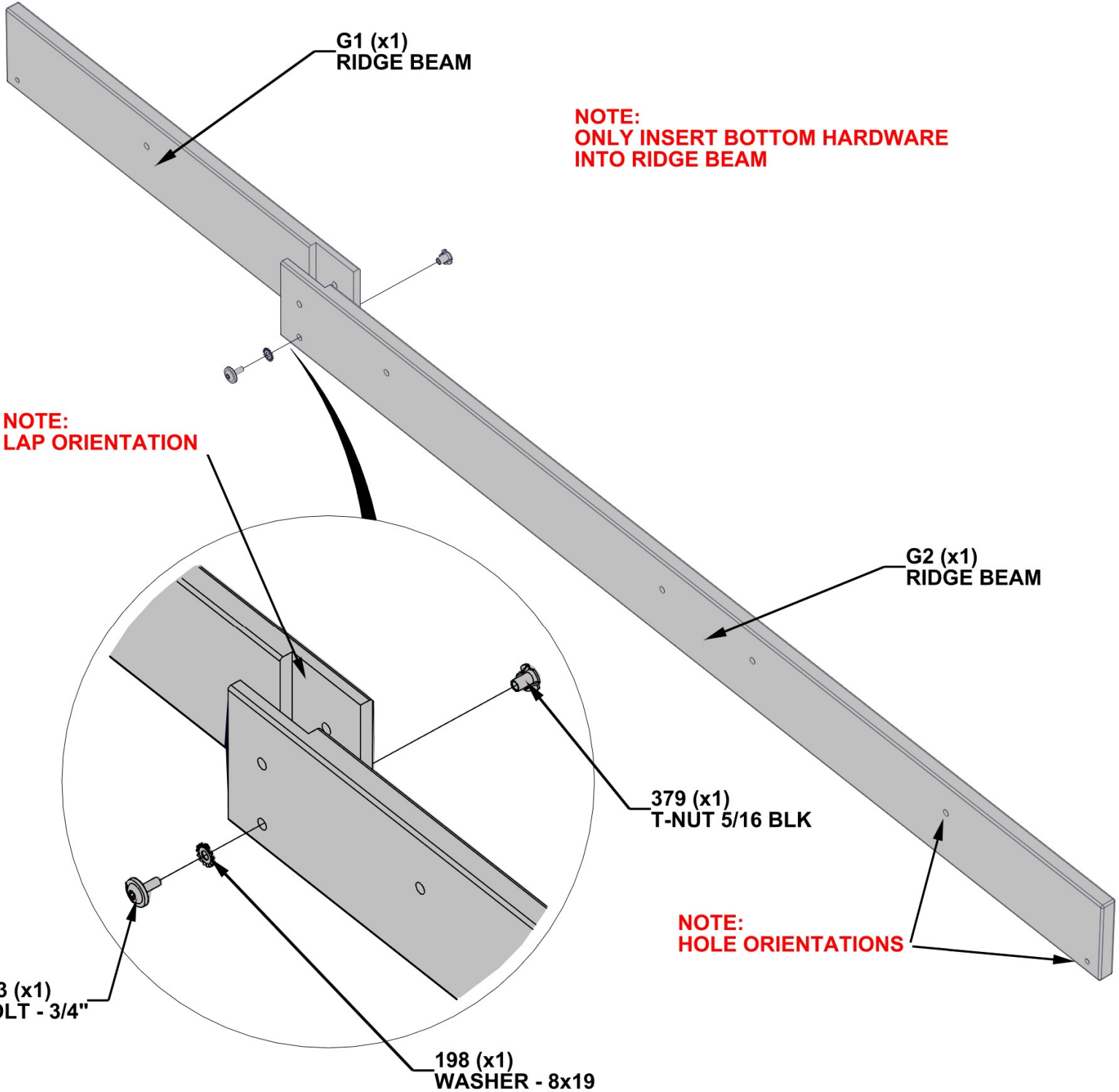

STEP 11 - GAZEBO ASSEMBLY

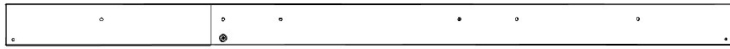

RIDGE ASSEMBLY

QTY	PART NUMBER	DESCRIPTION
2	H100653	NUT LOCK 1/4 BLK
2	H100406	BOLT WH 1/4x1 1/2 BLK
2	H100630	WASHER FLAT 8x19 BLK

ALIGN HOLE ON EACH END OF RIDGE ASSEMBLY FROM PREVIOUS STEP WITH RIDGE BRACKET.

**406 (x2)
BOLT - 1 1/2"**

**653 (x2)
LOCK NUT - 1/4"**

**630 (x2)
WASHER - 8x19**

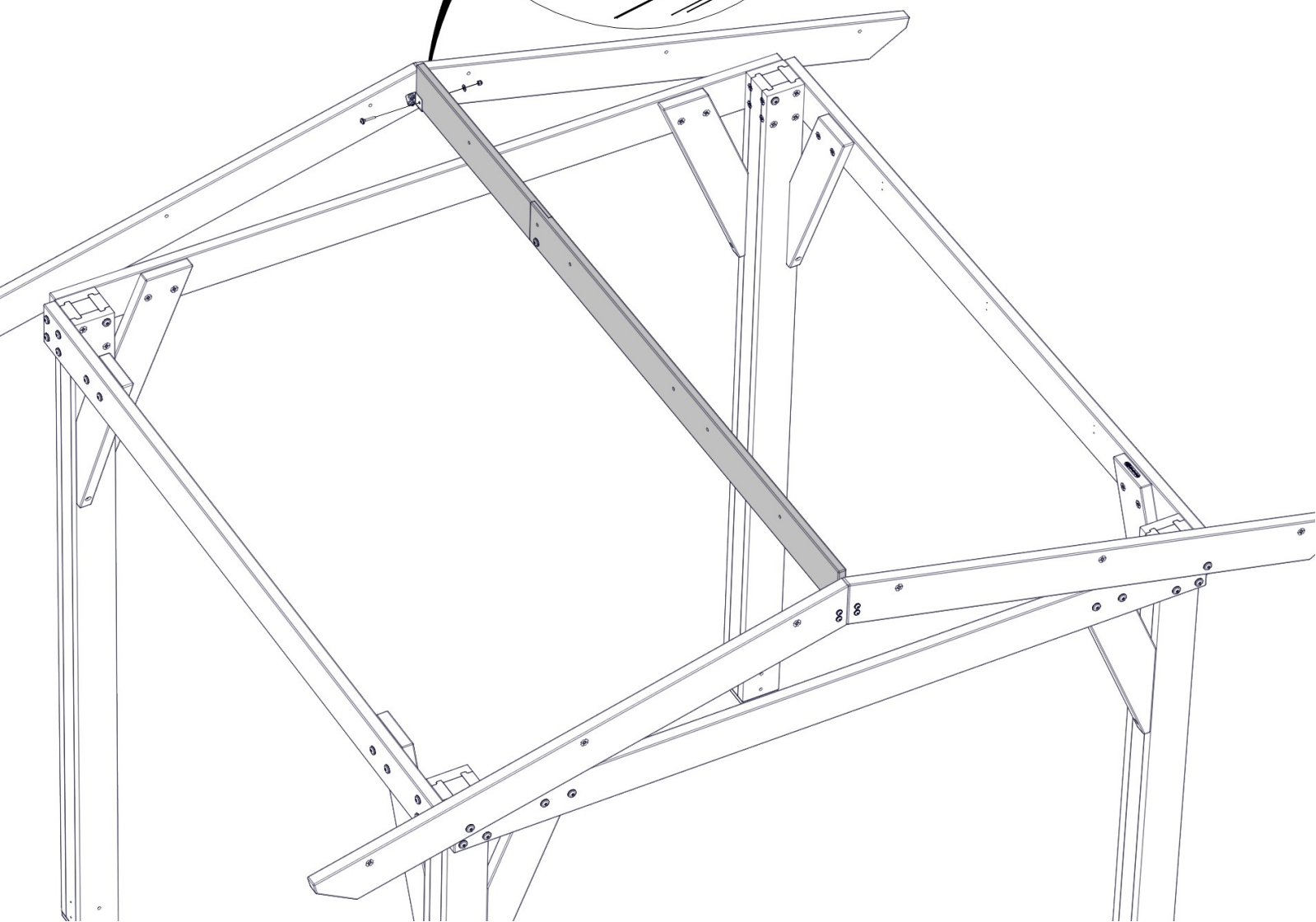
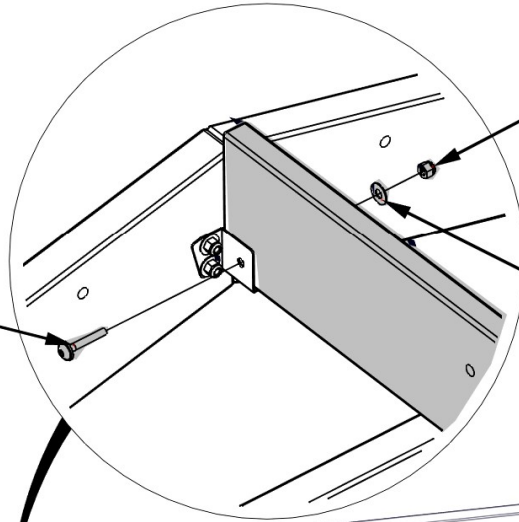

STEP 12 - GAZEBO ASSEMBLY

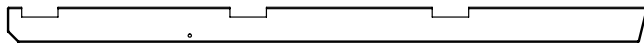

E4 | RAFTER-W4L16368
(x6) | 1 7/16"x3 3/8"x62 5/16" (36x86x1583)

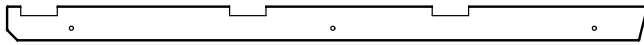

E5 | RAFTER-W4L16372
(x4) | 1 7/16"x3 3/8"x62 5/16" (36x86x1583)



H3 | RIDGE SUPPORT-W4L16371
(x4) | 15/16"x3 3/8"x47 9/16" (24x86x1208)

QTY	PART NUMBER	DESCRIPTION
20	H101030	SCREW CONFIRMAT 7x2 BLK

LAY RAFTERS FLAT, ALIGNING PILOT HOLES WITH HOLES IN H3 BOARDS. BOTTOM EDGE WILL BE FLUSH.

COMPLETE THIS STEP TWICE.

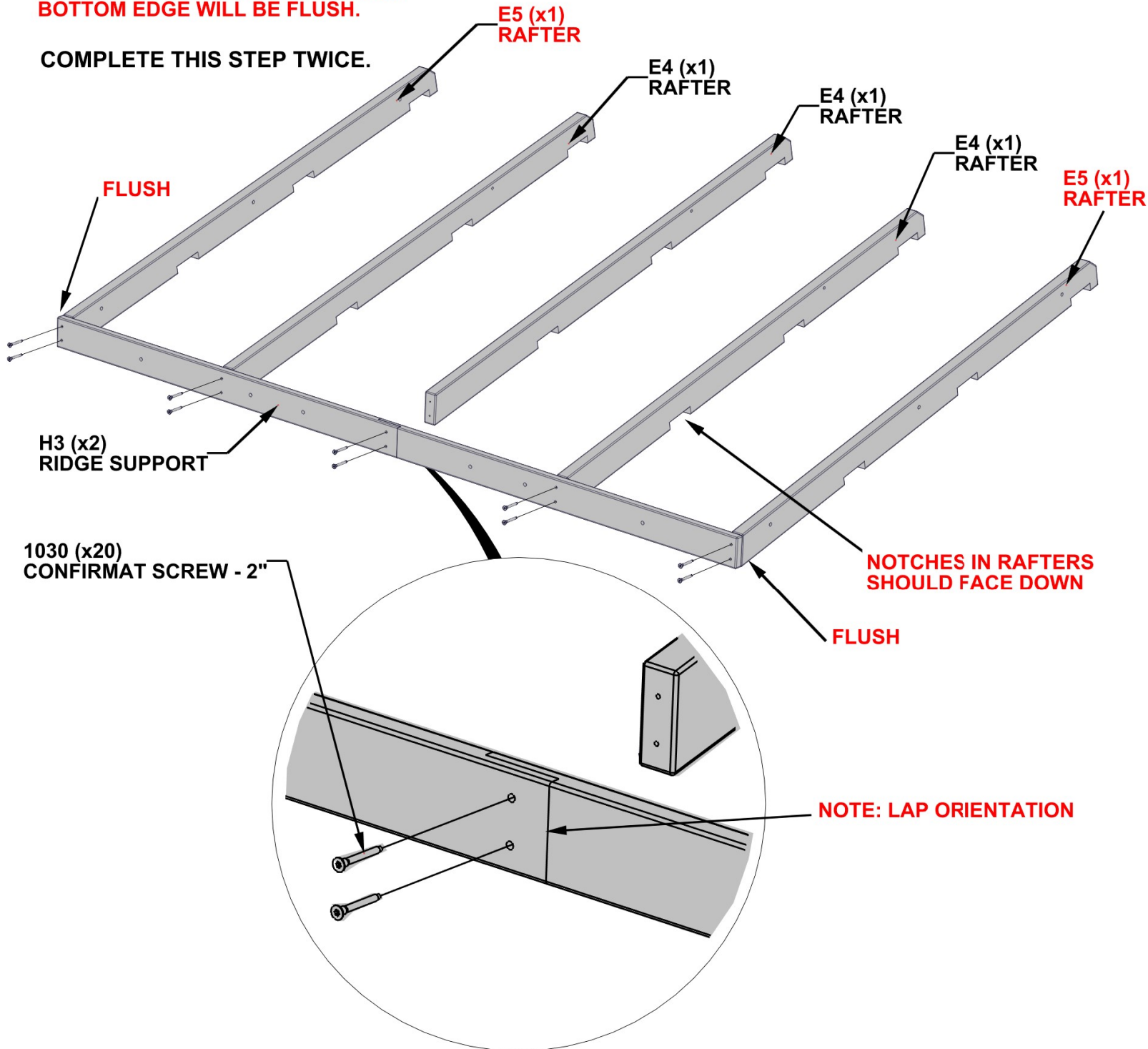

STEP 13 - GAZEBO ASSEMBLY

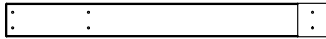

H1 | PURLIN-W4L16369
 (x2) | 15/16"x3 3/8"x32 9/16" (24x86x827)

QTY	PART NUMBER	DESCRIPTION
20	H100391	SCREW PFH 8x2 BLK

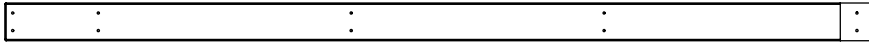

H2 | PURLIN-W4L16370
 (x2) | 15/16"x3 3/8"x77 15/16" (24x86x1979)

COMPLETE THIS STEP TWICE.

FLIP ASSEMBLY FROM PREVIOUS STEP OVER. POSITION H1 AND H2 PURLIN IN PLACE. MEASURE DIAGONALLY AND SQUARE AS NEEDED. MEASUREMENT SHOULD BE 111 5/8 in [2837 mm].

ONCE SQUARE, INSERT SCREWS. RE-MEASURE CORNER TO CORNER.

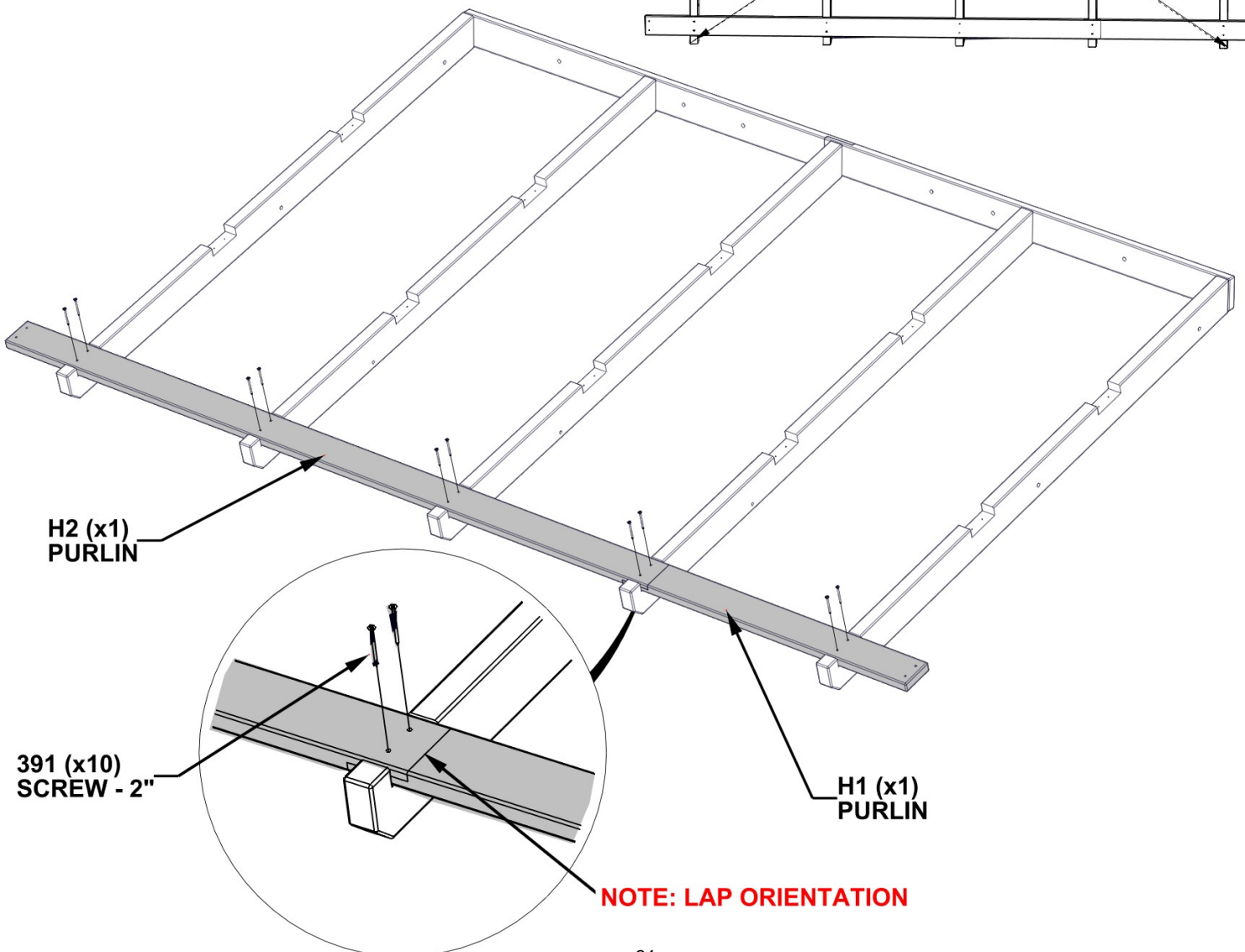
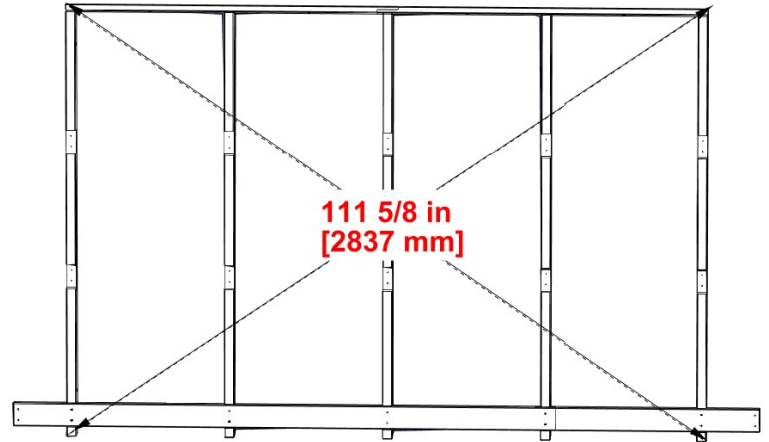

NOTE: LAP ORIENTATION

STEP 14 - GAZEBO ASSEMBLY

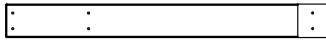

H1 | PURLIN-W4L16369
 (x4) | 15/16"x3 3/8"x32 9/16" (24x86x827)

QTY	PART NUMBER	DESCRIPTION
40	H100391	SCREW PFH 8x2 BLK

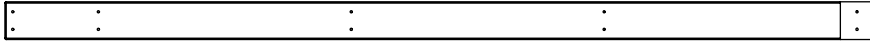

H2 | PURLIN-W4L16370
 (x4) | 15/16"x3 3/8"x77 15/16" (24x86x1979)

COMPLETE THIS STEP TWICE.

NOTE: LAP ORIENTATION

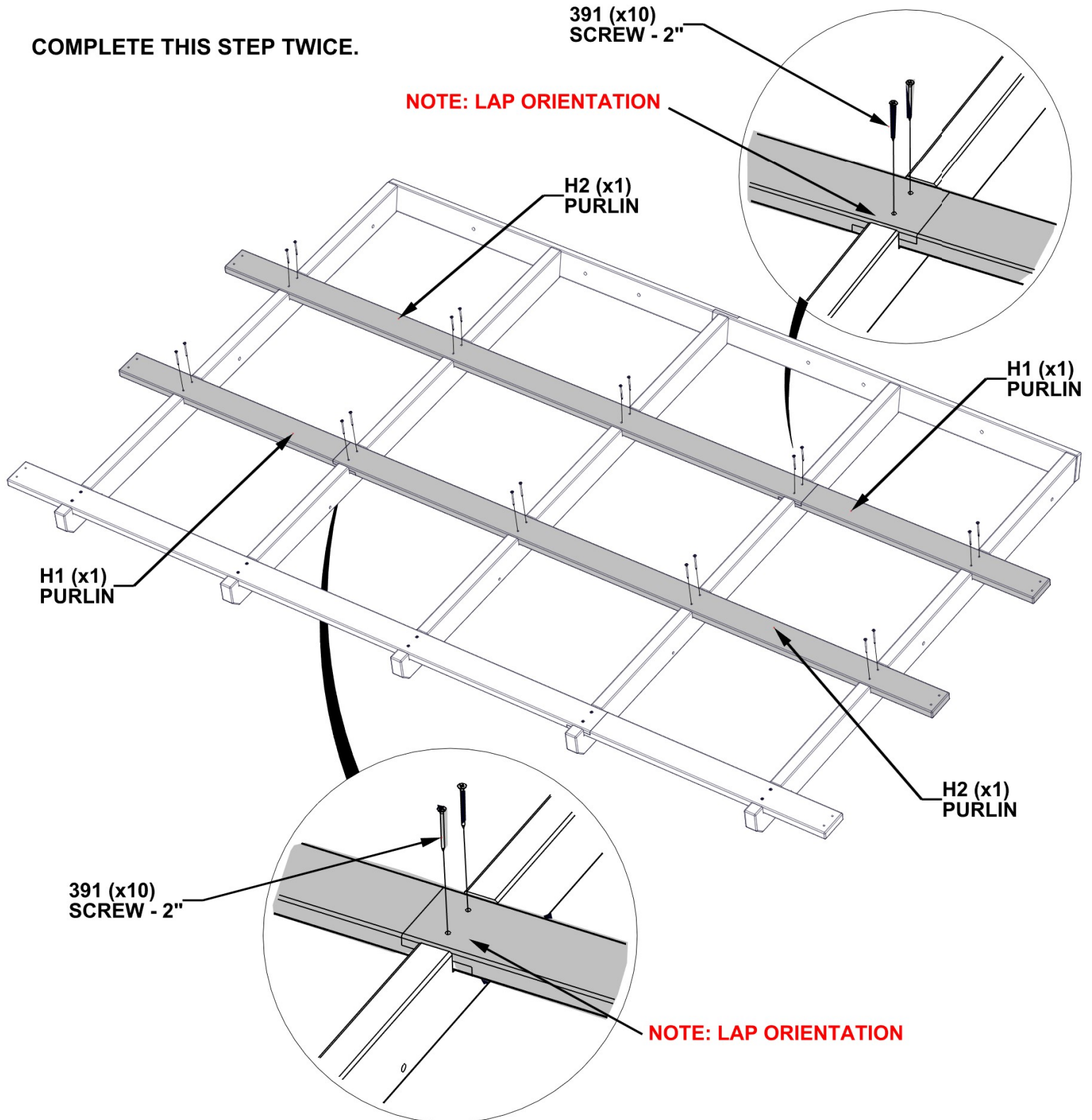

STEP 15 - GAZEBO ASSEMBLY

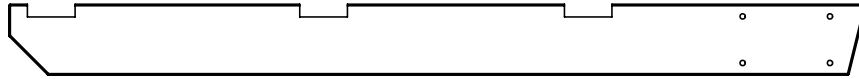

D5 | RAFTER-W4L16367
 (x4) | 1 7/16"x5 1/4"x63 13/16" (36x134x1621)

QTY	PART NUMBER	DESCRIPTION
16	H100379	T-NUT 5/16" BLK

COMPLETE THIS STEP TWICE.

INSERT T-NUTS INTO BOTH RAFTERS FOR EACH END OF ROOF ASSEMBLY. THESE CONNECTIONS WILL BE USED WHEN ATTACHING ROOF PANEL TO ASSEMBLY.

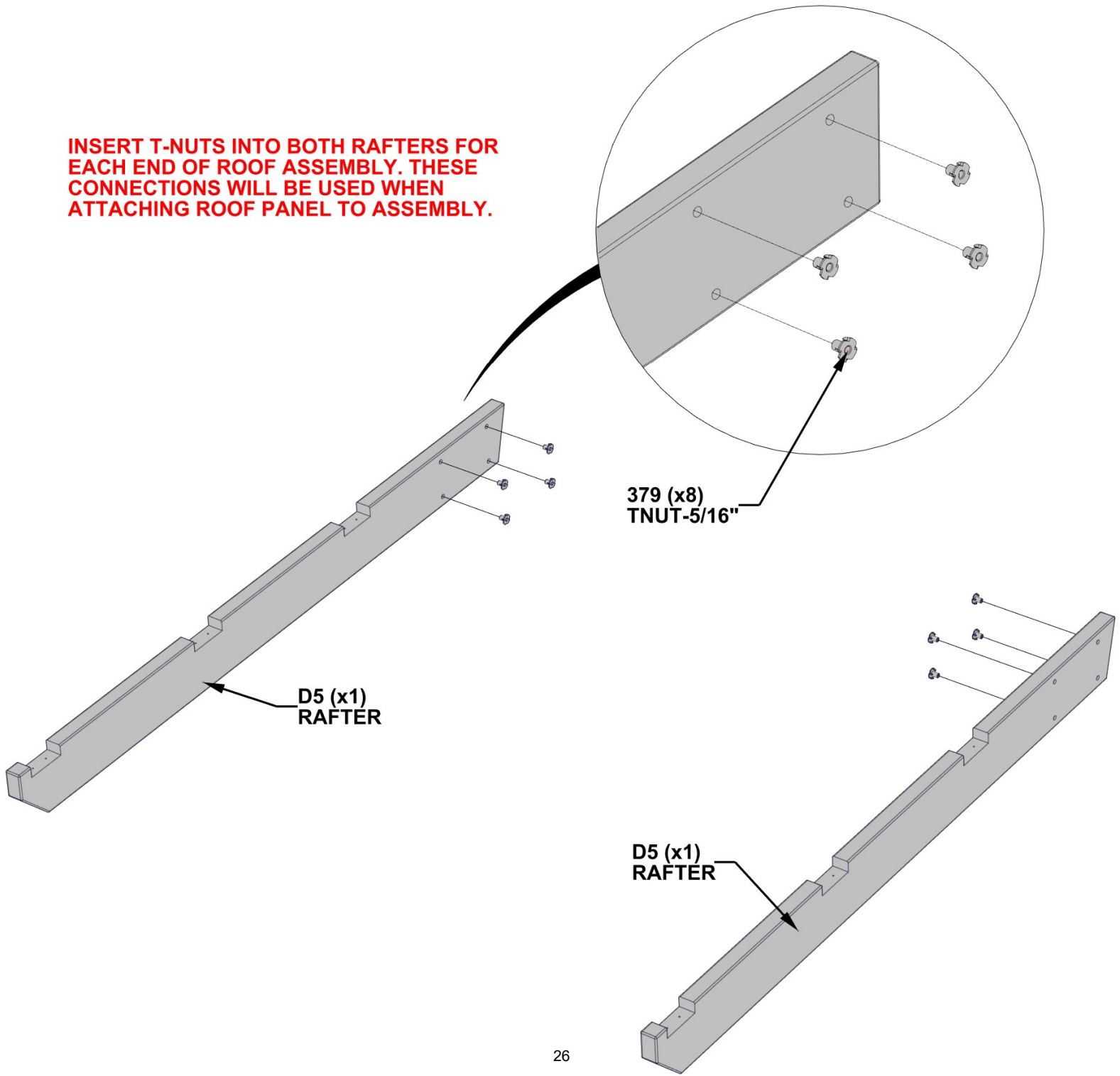

STEP 16 - GAZEBO ASSEMBLY

QTY	PART NUMBER	DESCRIPTION
24	H100391	SCREW PFH 8x2 BLK

COMPLETE THIS STEP TWICE.

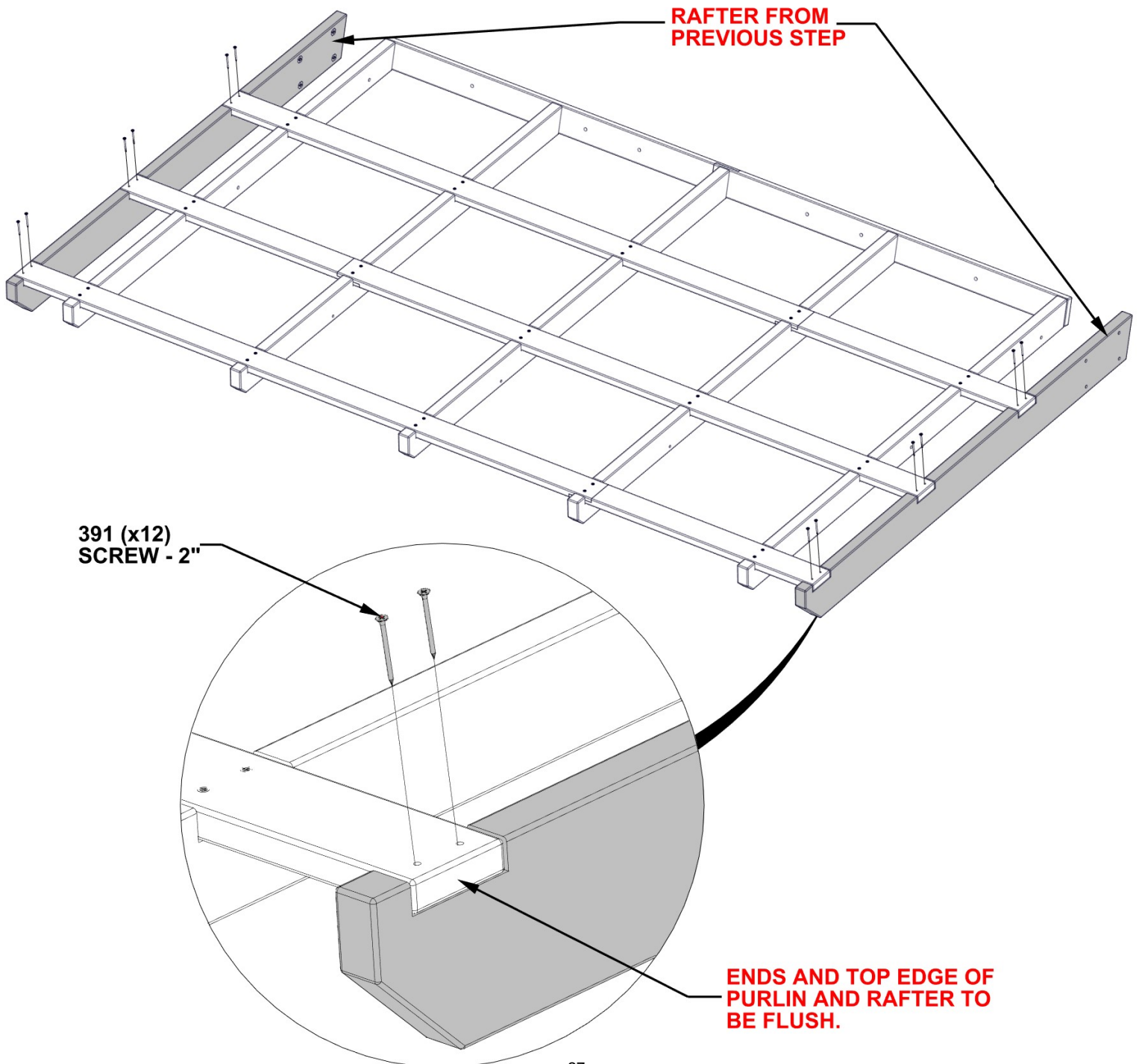

STEP 17 - GAZEBO ASSEMBLY

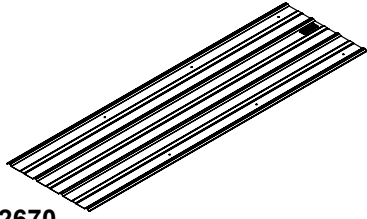

A4M02670
(x12) | 29 GA STEEL SHEETING

QTY	PART NUMBER	DESCRIPTION
72	H101117	SCREW WOODGRIP 10-16x3/4" BLK

NOTE:
WARNING:
GLOVES SHOULD BE WORN WHEN HANDLING ROOF PANELS. EDGES ARE SHARP. REMOVE BLUE FILM FROM EACH SHEET.

1. LOOKING AT THE FRONT OF THE UNIT AS PICTURED BELOW, PLACE TIN SHEETS DOWN.
2. STARTING AT THE LEFT SIDE AND WORKING TOWARD THE RIGHT SIDE OVERLAPPING BY ONE RIB.
3. FLUSH FRONT EDGE OF SHEETS AND CENTER ON ROOF. LEAVE EQUAL GAPS ON BOTH LEFT AND RIGHT SIDES.

COMPLETE THIS STEP TWICE.

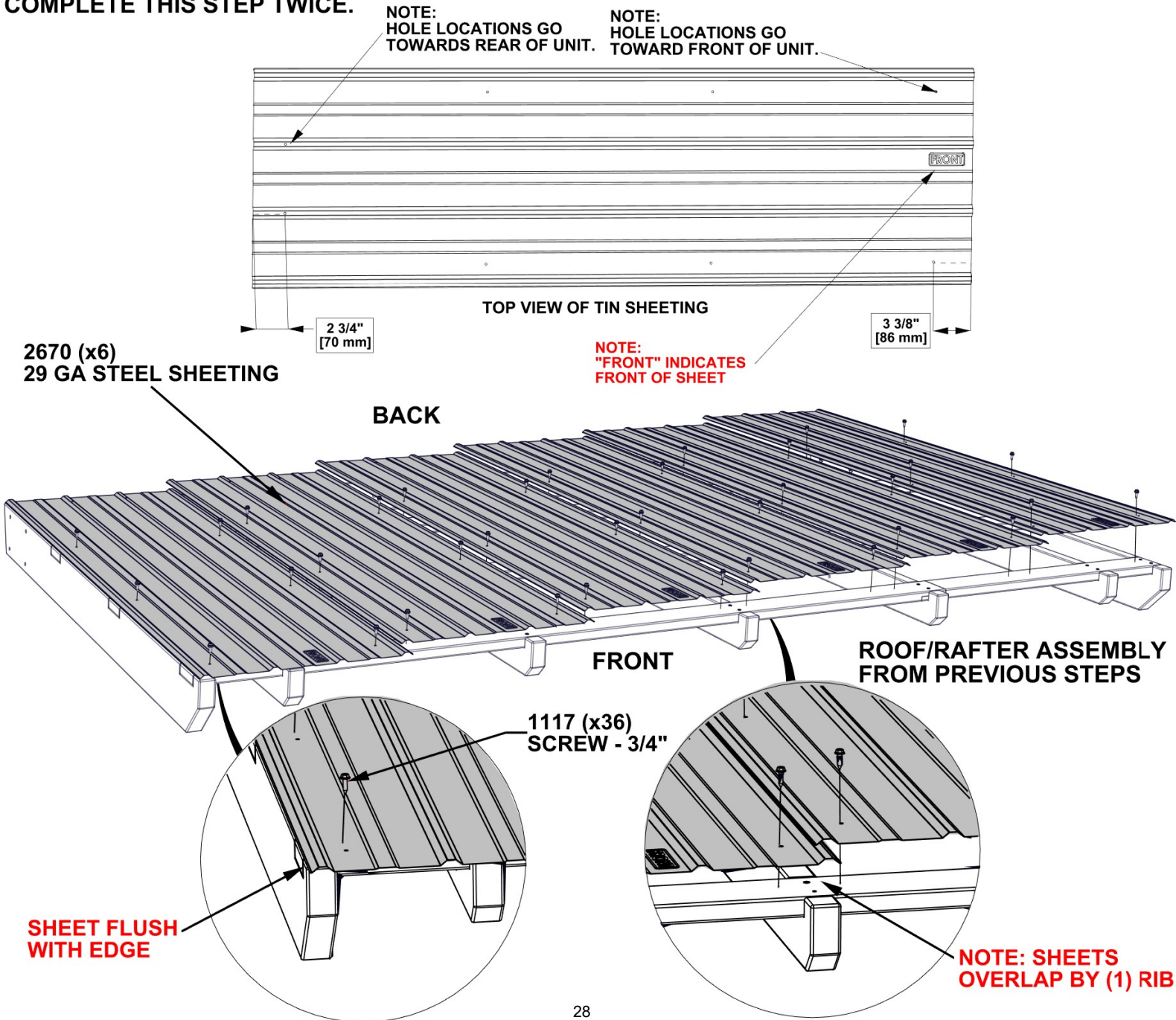

STEP 18 - GAZEBO ASSEMBLY

QTY	PART NUMBER	DESCRIPTION
6	H100195	BOLT WH 5/16x2 3/4 BLK
6	H100198	WASHER LOCK EXT 8x19

NOTE:

1. BEFORE BEGINNING, MAKE SURE T-NUTS HAVE BEEN INSTALLED FROM STEP 8.
2. WITH AT LEAST TWO PEOPLE, LIFT ASSEMBLED ROOF PANEL AND SLIDE IT ONTO OUTER RAFTERS.
3. CLAMP ROOF PANEL TO RIDGE AS NEEDED TO HOLD IN PLACE.
4. FASTEN BOTH SIDES OF ROOF ASSEMBLY AS SHOWN.

TIP: USE RIGHT ANGLE DRILL ADAPTER TO INSTALL BOLTS IN THIS STEP.

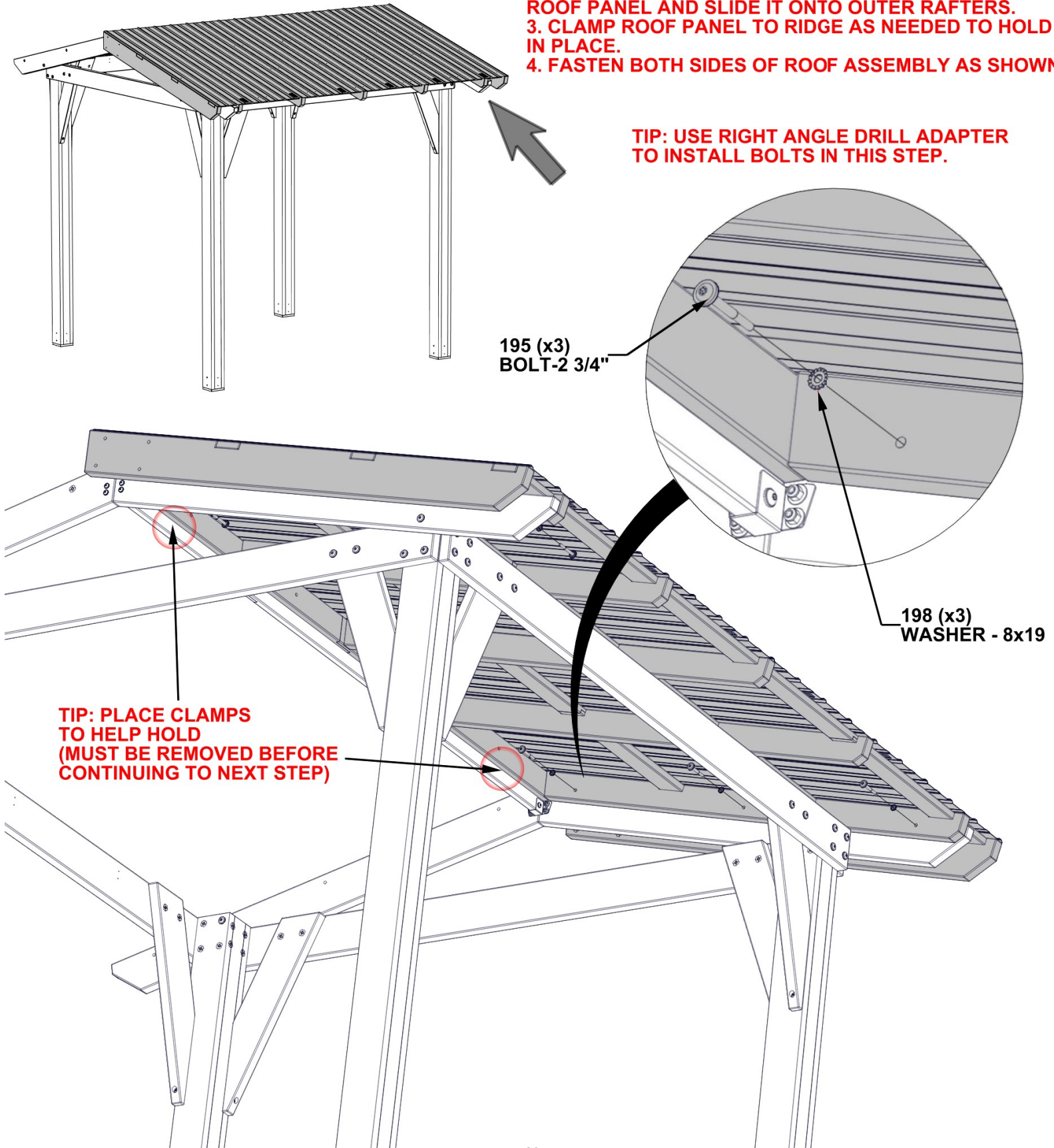

STEP 19 - GAZEBO ASSEMBLY

QTY	PART NUMBER	DESCRIPTION
6	H100195	BOLT WH 5/16x2 3/4 BLK
6	H100198	WASHER LOCK EXT 8x19

NOTE:

1. BEFORE BEGINNING, MAKE SURE T-NUTS HAVE BEEN INSTALLED FROM STEP 8.
2. WITH AT LEAST TWO PEOPLE, LIFT ASSEMBLED ROOF PANEL AND SLIDE IT ONTO OUTER RAFTERS.
3. CLAMP ROOF PANEL TO RIDGE AS NEEDED TO HOLD IN PLACE.
4. FASTEN BOTH SIDES OF ROOF ASSEMBLY AS SHOWN.

TIP: USE RIGHT ANGLE DRILL ADAPTER TO INSTALL BOLTS IN THIS STEP.

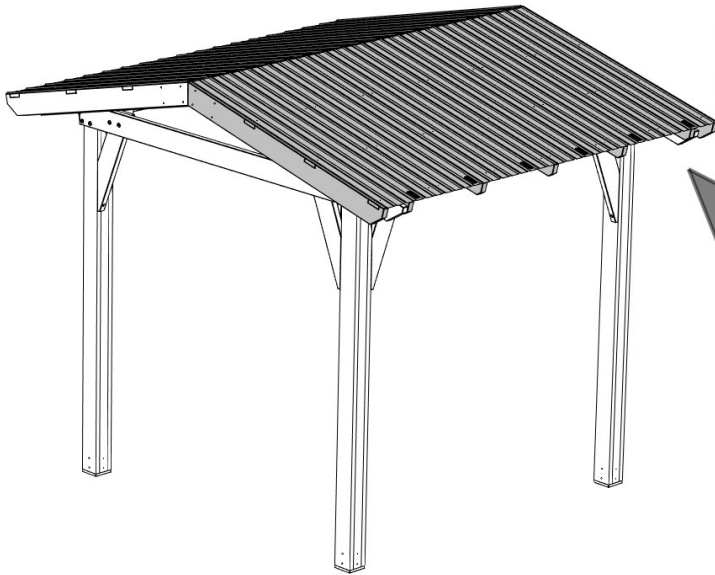

195 (x3)
BOLT-2 3/4"

198 (x3)
WASHER - 8x19

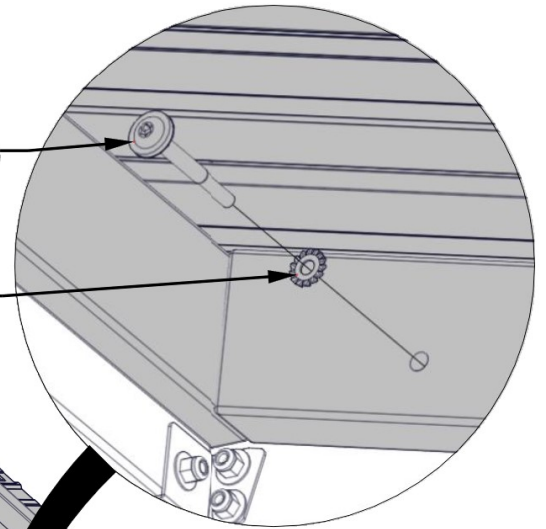

TIP: PLACE CLAMPS TO HELP HOLD.

STEP 20 - GAZEBO ASSEMBLY

QTY	PART NUMBER	DESCRIPTION
6	H100479	NUT LOCK 5/16 BLK
6	H100484	BOLT WH 5/16x3 1/4 BLK
6	H100198	WASHER LOCK EXT 8x19
6	H100770	WASHER FLAT 5/16 BLK

TIP: USE RIGHT ANGLE DRILL ADAPTER AS NEEDED TO INSTALL BOLTS IN THIS STEP.

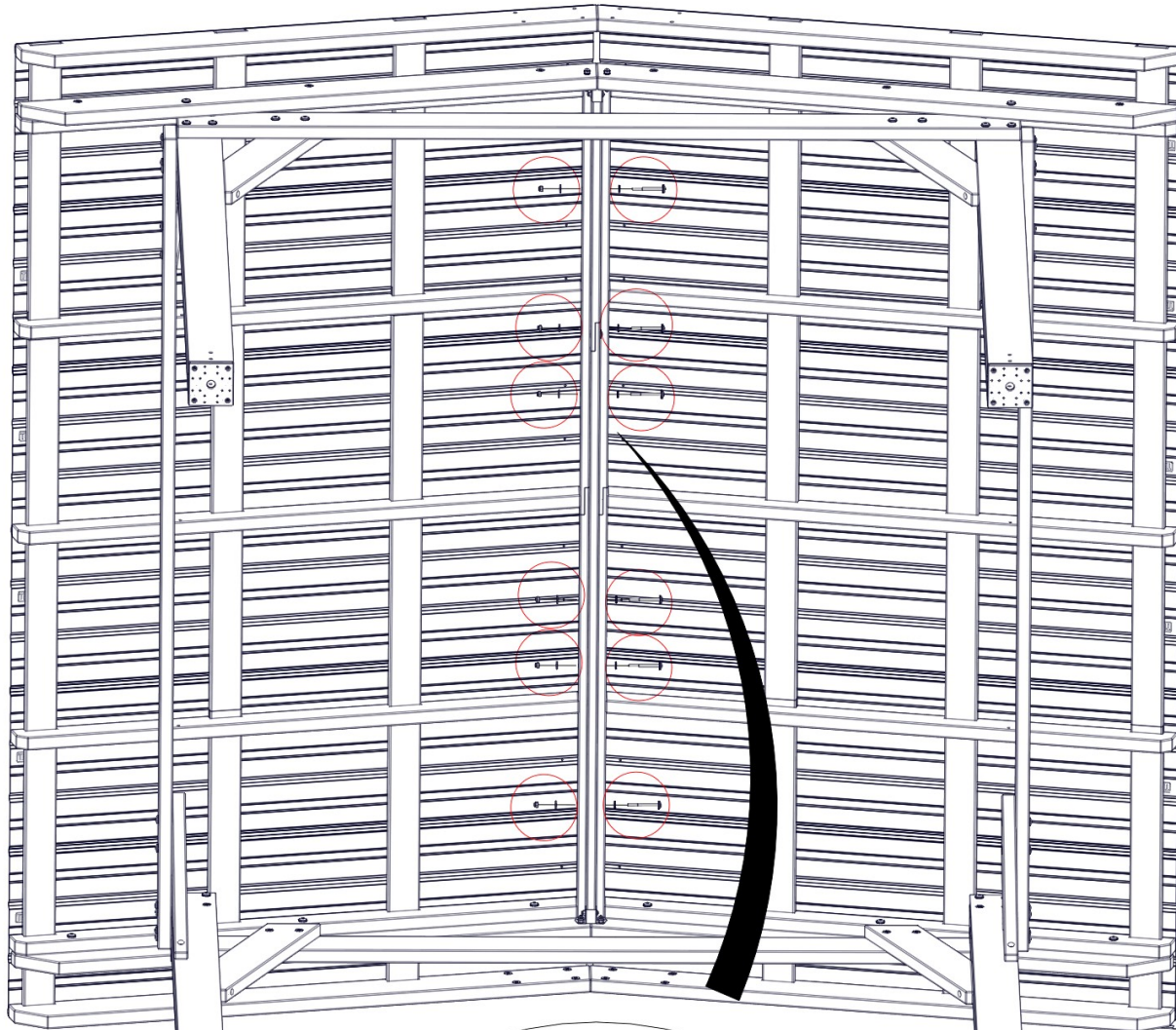

479 (x6)
LOCK NUT - 5/16"

770 (x6)
WASHER - 5/16"

198 (x6)
WASHER - 8x19

484 (x6)
BOLT - 3 1/4"

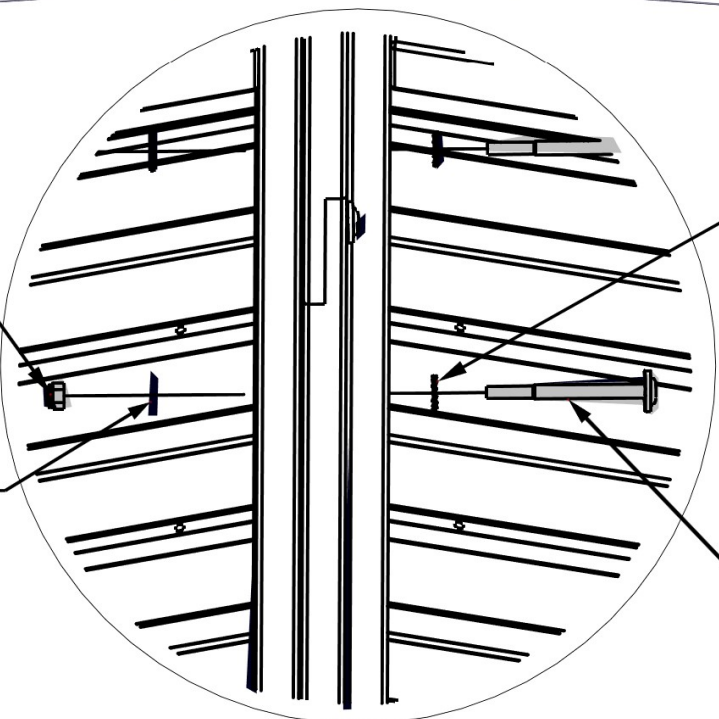

STEP 21 - GAZEBO ASSEMBLY

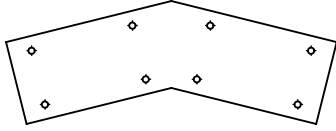

A4M01508
(x2) | GABLE BRACKET

QTY	PART NUMBER	DESCRIPTION
16	H100407	BOLT WH 5/16x1 1/2 BLK

508 (x2)
GABLE BRACKET

407 (x16)
BOLT - 1 1/2"

**ATTACH GABLE BRACKET TO OUTER
RAFTERS ON BOTH ENDS OF ROOF.
BOLTS WILL FASTEN TO T-NUTS THAT
WERE PREVIOUSLY INSTALLED IN STEP 16.**

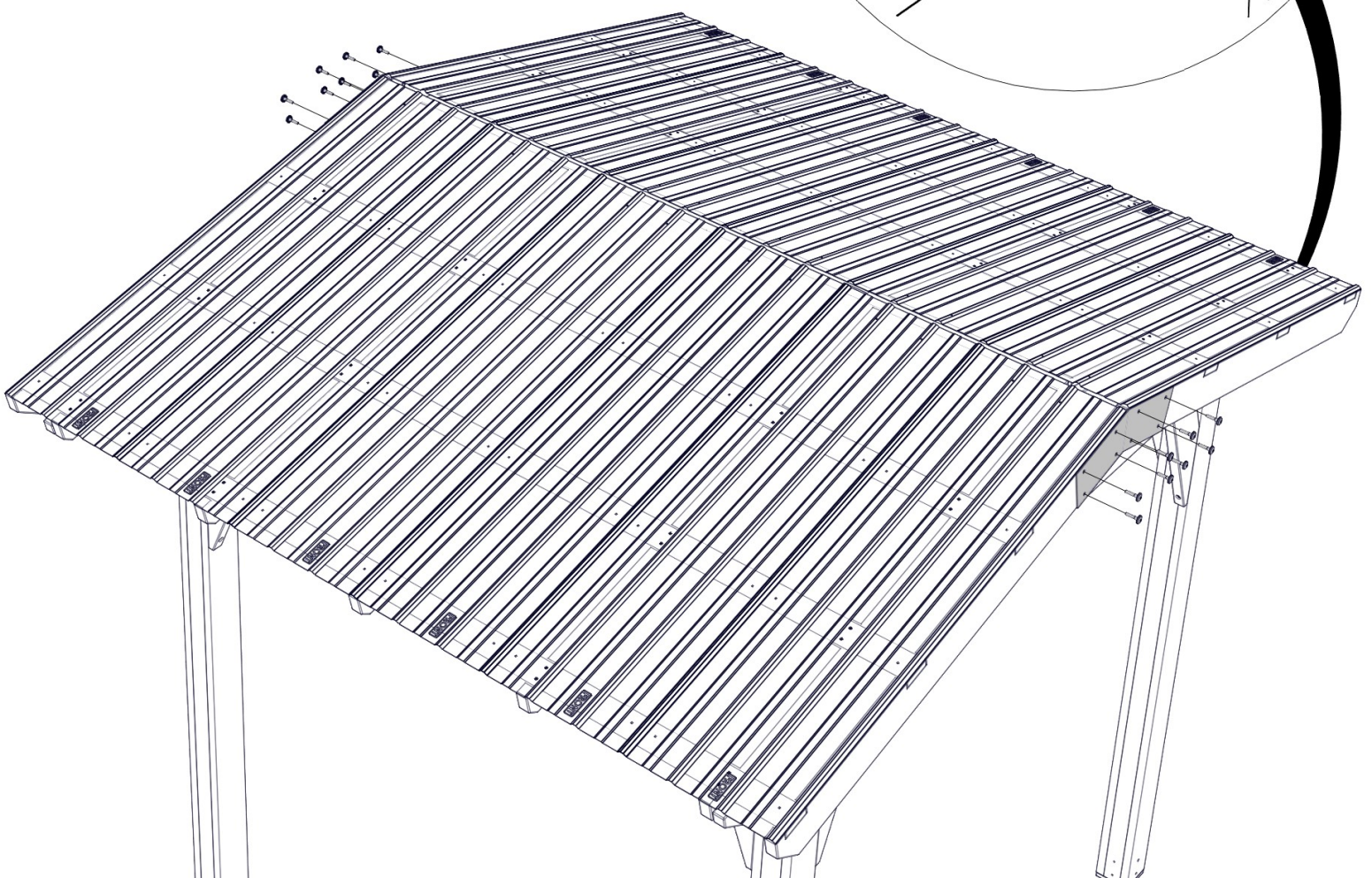
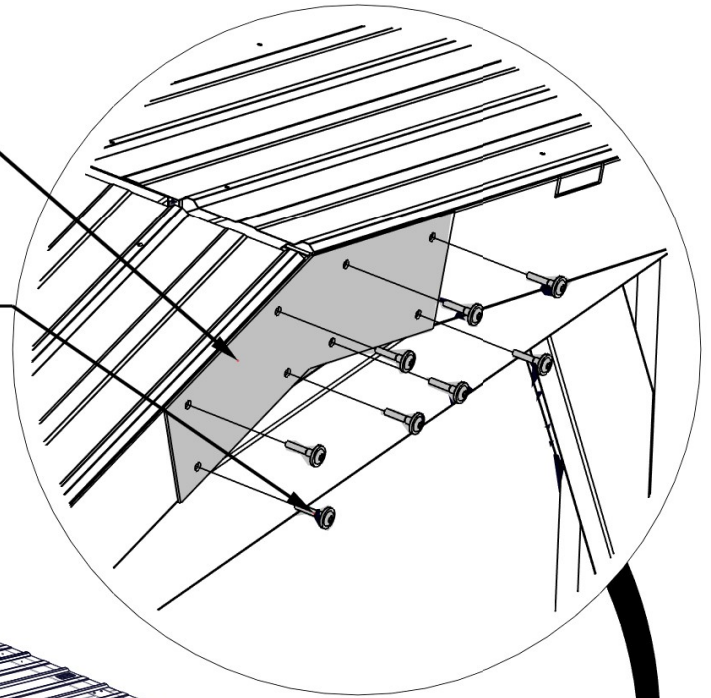

STEP 22 - GAZEBO ASSEMBLY

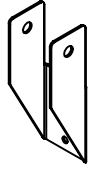

A4M01228
(x6) | **RAFTER BRACKET**

QTY	PART NUMBER	DESCRIPTION
6	H100653	NUT LOCK 1/4 BLK
6	H100488	BOLT WH 1/4x2 BLK
6	H100630	WASHER FLAT 8x19 BLK
12	H100536	SCREW PWH 8x1 1/4 BLK

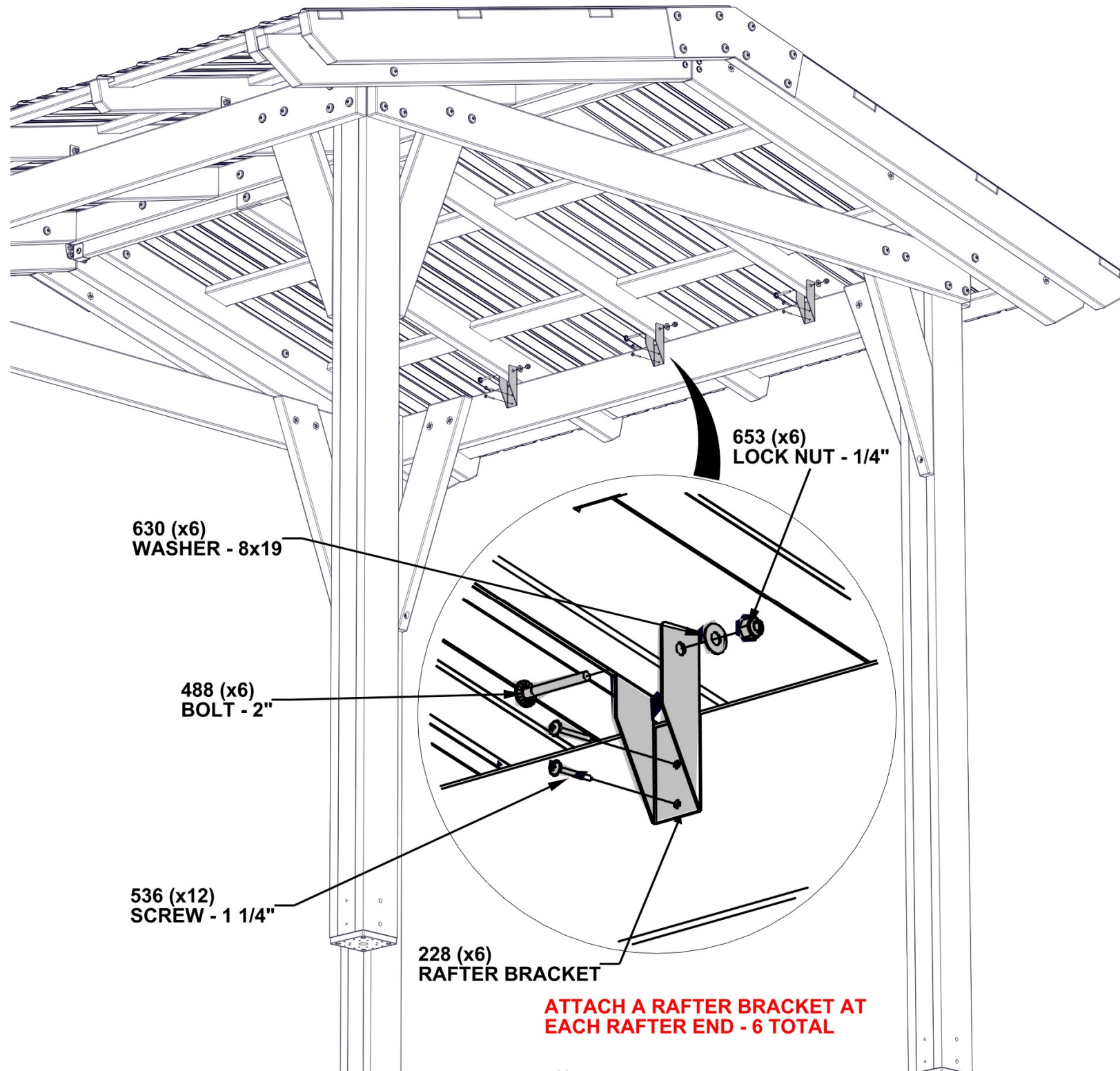

STEP 23 - GAZEBO ASSEMBLY

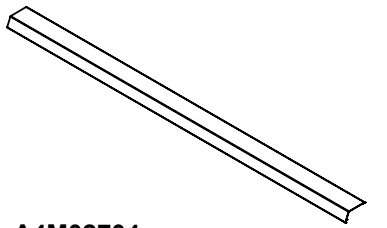

A4M02704 (x4) | ROOF EDGE TRIM



A4M02706 (x4) | CORNER SPLICE TRIM

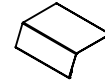

A4M02707 (x2) | ROOF EDGE TRIM SPLICE

QTY	PART NUMBER	DESCRIPTION
10	H101116	SCREW SELF TAPPING 1/4x1" BLK

REPEAT THIS STEP FOR OPPOSITE SIDE

LAYOUT ROOF EDGE TRIM, TRIM SPLICE, AND CORNER SPLICE AS SHOWN BELOW. SLIDE TRIM PIECE INTO SPLICE. ATTACH CORNER SPLICES BY PRESSING INTO EDGE TRIM.

NOTE: INSERT SCREWS AS SHOWN BELOW MAKE SURE SCREWS GO INTO TOP OF RIBS. DO NOT OVERTIGHTEN.

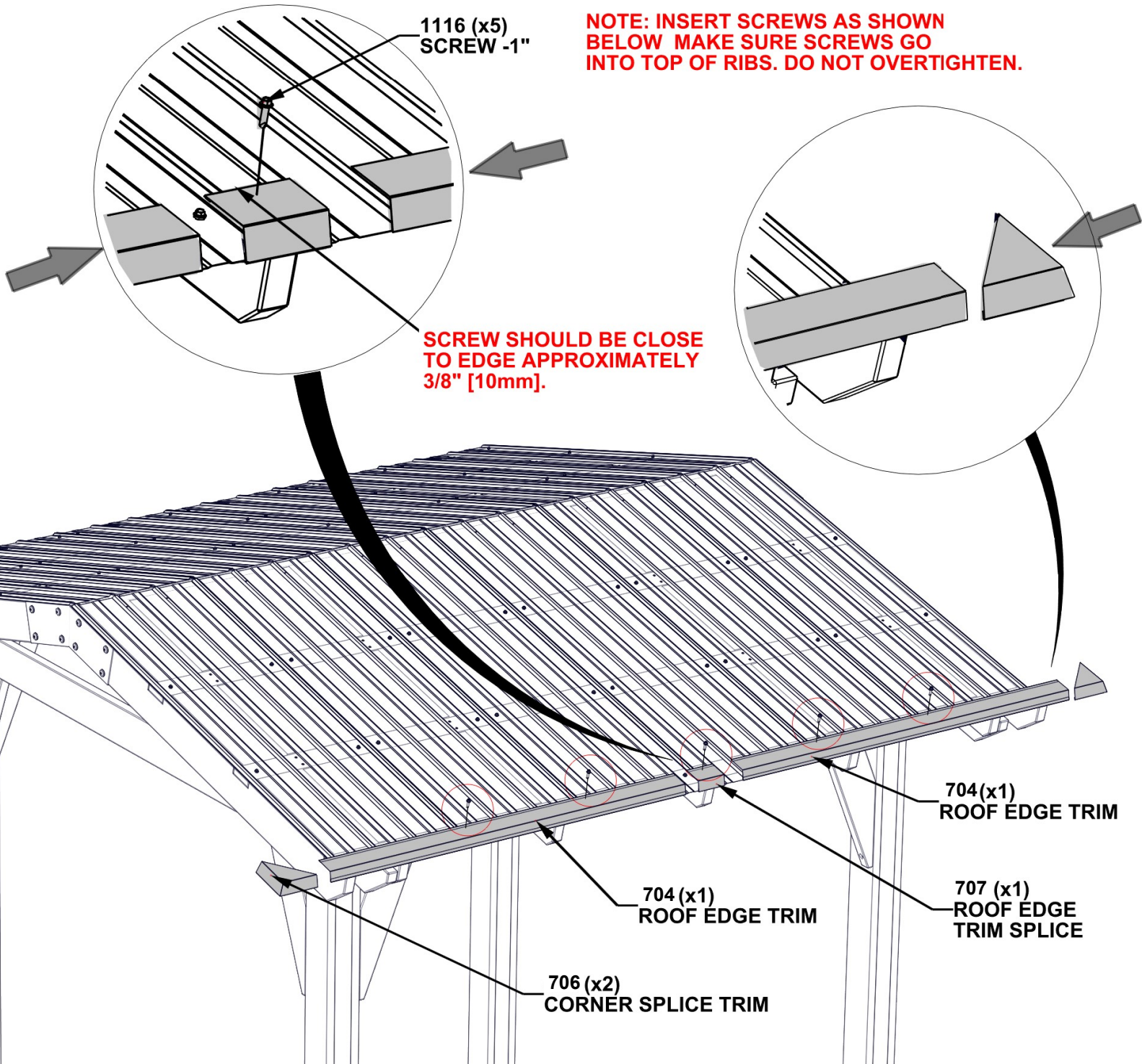

1116 (x5) SCREW -1"

SCREW SHOULD BE CLOSE TO EDGE APPROXIMATELY 3/8" [10mm].

704 (x1) ROOF EDGE TRIM

704 (x1) ROOF EDGE TRIM

707 (x1) ROOF EDGE TRIM SPLICE

706 (x2) CORNER SPLICE TRIM

STEP 24 - GAZEBO ASSEMBLY

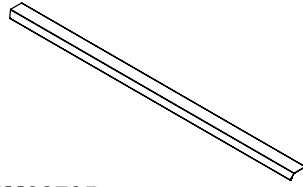

A4M02705 | ROOF EDGE TRIM
(x2)

PLACE ROOF EDGE TRIM ON SIDES OF ROOF. SLIDE EDGE UNDERNEATH CORNER SPLICE.

FLUSH BOTH EDGES OF TRIM PIECES AT TOP OF RIDGE.

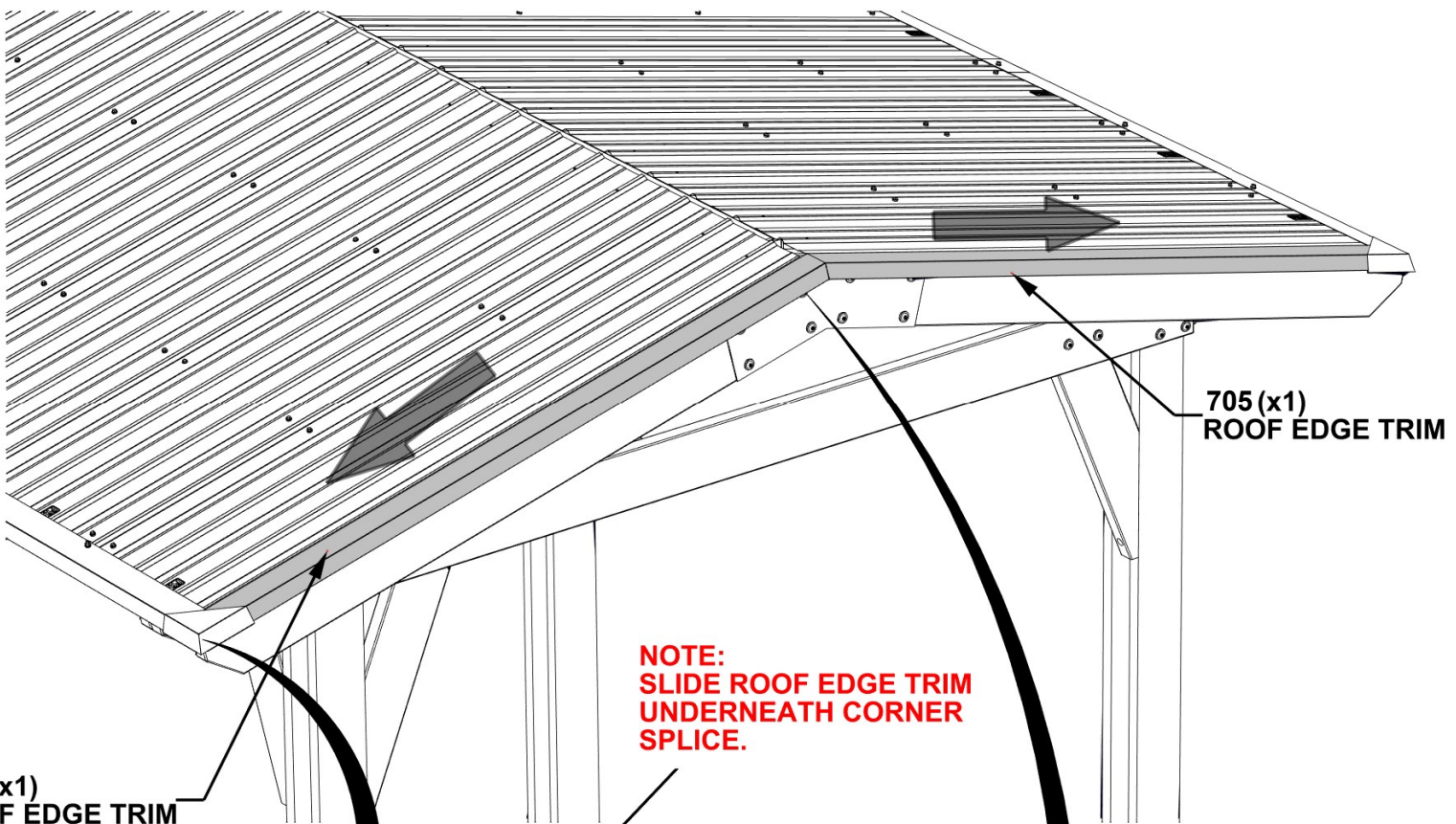

705 (x1)
ROOF EDGE TRIM

705 (x1)
ROOF EDGE TRIM

**NOTE:
SLIDE ROOF EDGE TRIM
UNDERNEATH CORNER
SPLICE.**

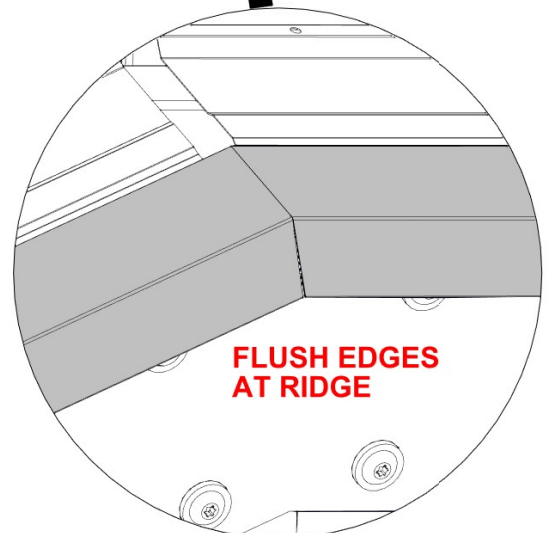
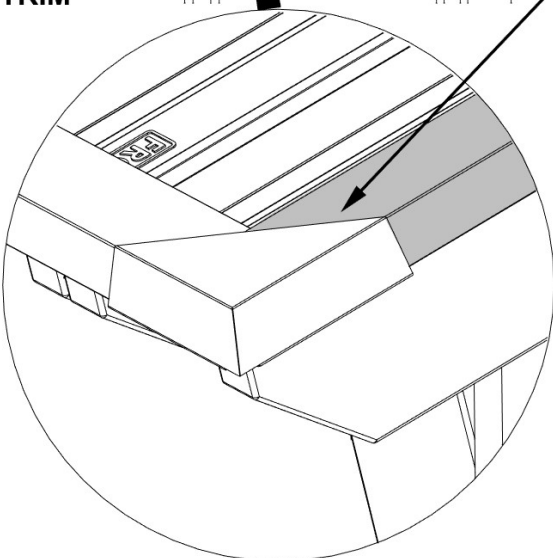

STEP 25 - GAZEBO ASSEMBLY

QTY	PART NUMBER	DESCRIPTION
6	H101116	SCREW SELF TAPPING 1/4x1" BLK

NOTE:
BEFORE INSTALLING SCREWS, MAKE SURE
EDGES ARE FLUSH AT TOP OF RIDGE.

**INSERT SCREWS AS SHOWN TO FASTEN
TRIM PIECES. DO NOT OVERTIGHTEN.**

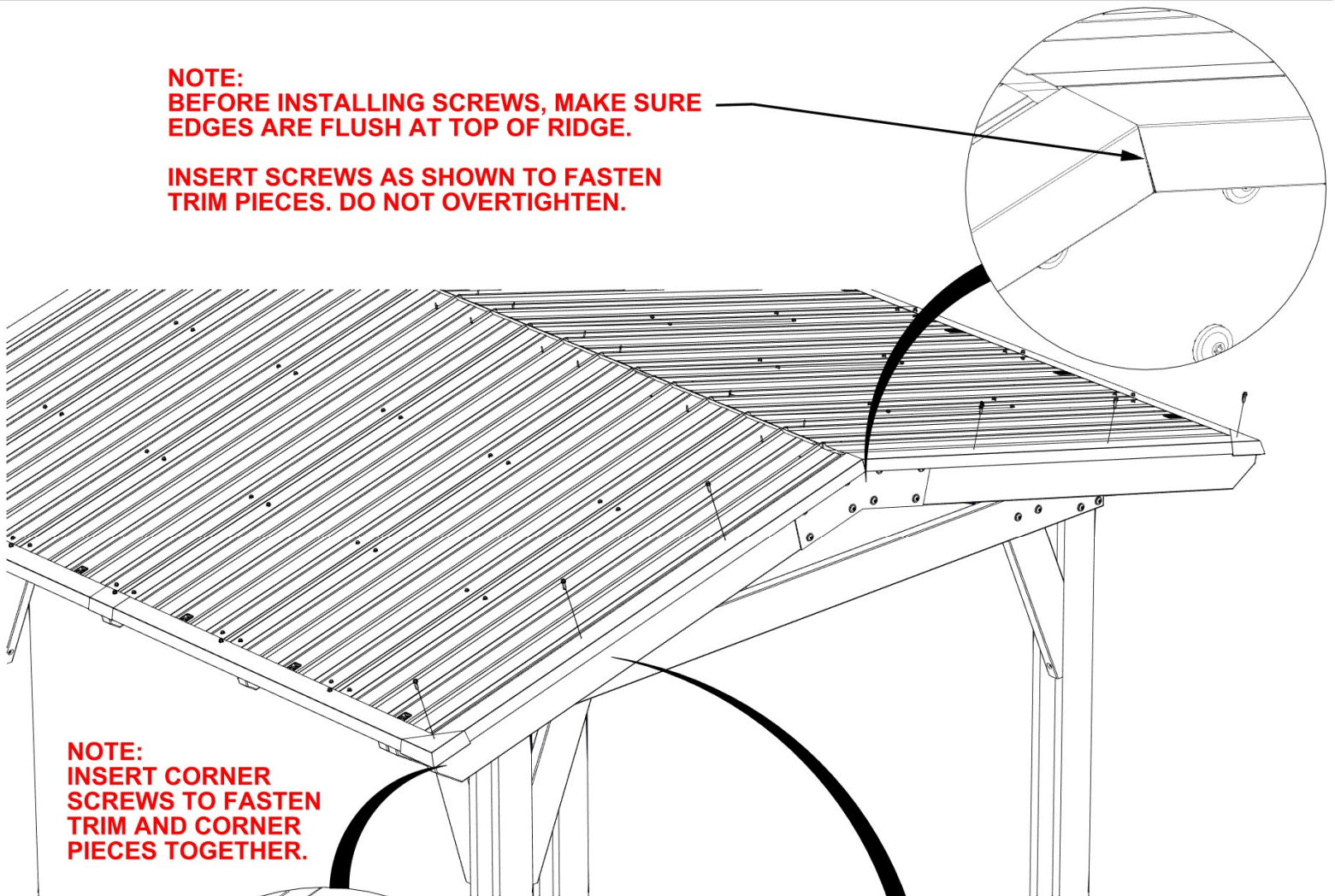

NOTE:
INSERT CORNER
SCREWS TO FASTEN
TRIM AND CORNER
PIECES TOGETHER.

1116 (x6)
SCREW - 1"

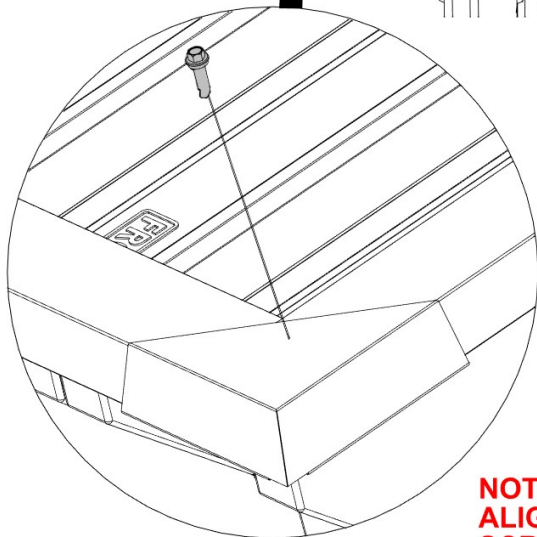

NOTE:
ALIGN SCREWS WITH
SCREWS IN SHEET.

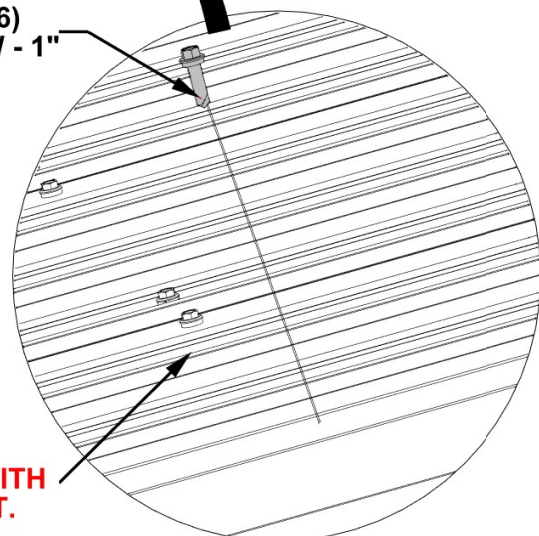

STEP 26 - GAZEBO ASSEMBLY

**REPEAT STEPS 24-25 TO
INSTALL ROOF EDGE
TRIM ON OTHER SIDE**

STEP 27 - GAZEBO ASSEMBLY

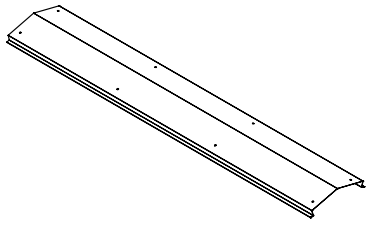

A4M02710
(x2) | RIDGE CAP 29 GA

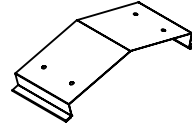

A4M02709
(x1) | RIDGE CAP SPLICE

SLIDE EACH RIDGE CAP INTO THE RIDGE CAP SPLICE UNTIL CENTERED.

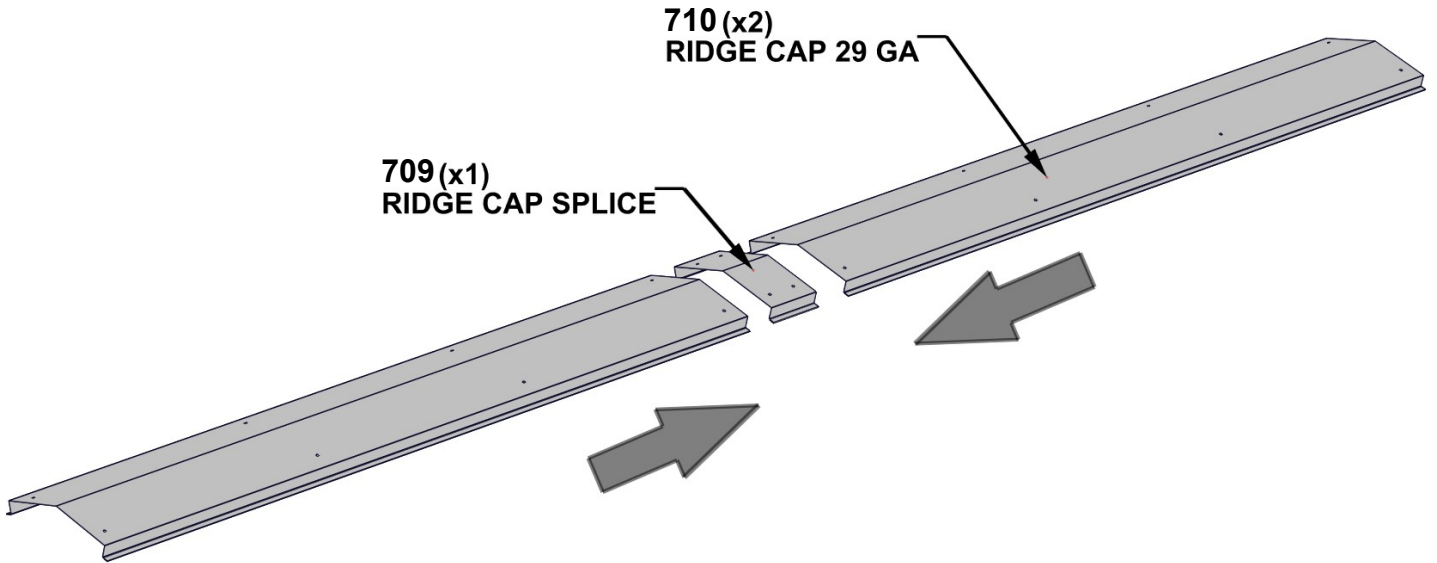

STEP 28A - GAZEBO ASSEMBLY

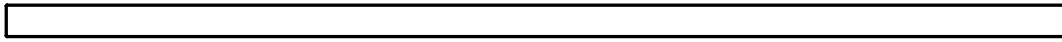

J2 | RIDGE CAP STIFFENER-W4L16374
 (x2) | 15/16"x2 3/8"x75 9/16" (24x60x1914)



J1 | RIDGE CAP STIFFENER-W4L16373
 (x2) | 15/16"x2 3/8"x32 1/8" (24x60x810)



A6P00513
 (x2) | RIDGE CAP PROTECTOR

QTY	PART NUMBER	DESCRIPTION
16	H101117	SCREW WOODGRIP 10-16x3/4" BLK

ASSEMBLE BY ALIGNING THE HOLES ON EACH RIDGE CAP TO THE HOLES IN THE RIDGE CAP SPLICE

FINAL LENGTH - 8'-11 3/8" [2728 mm]

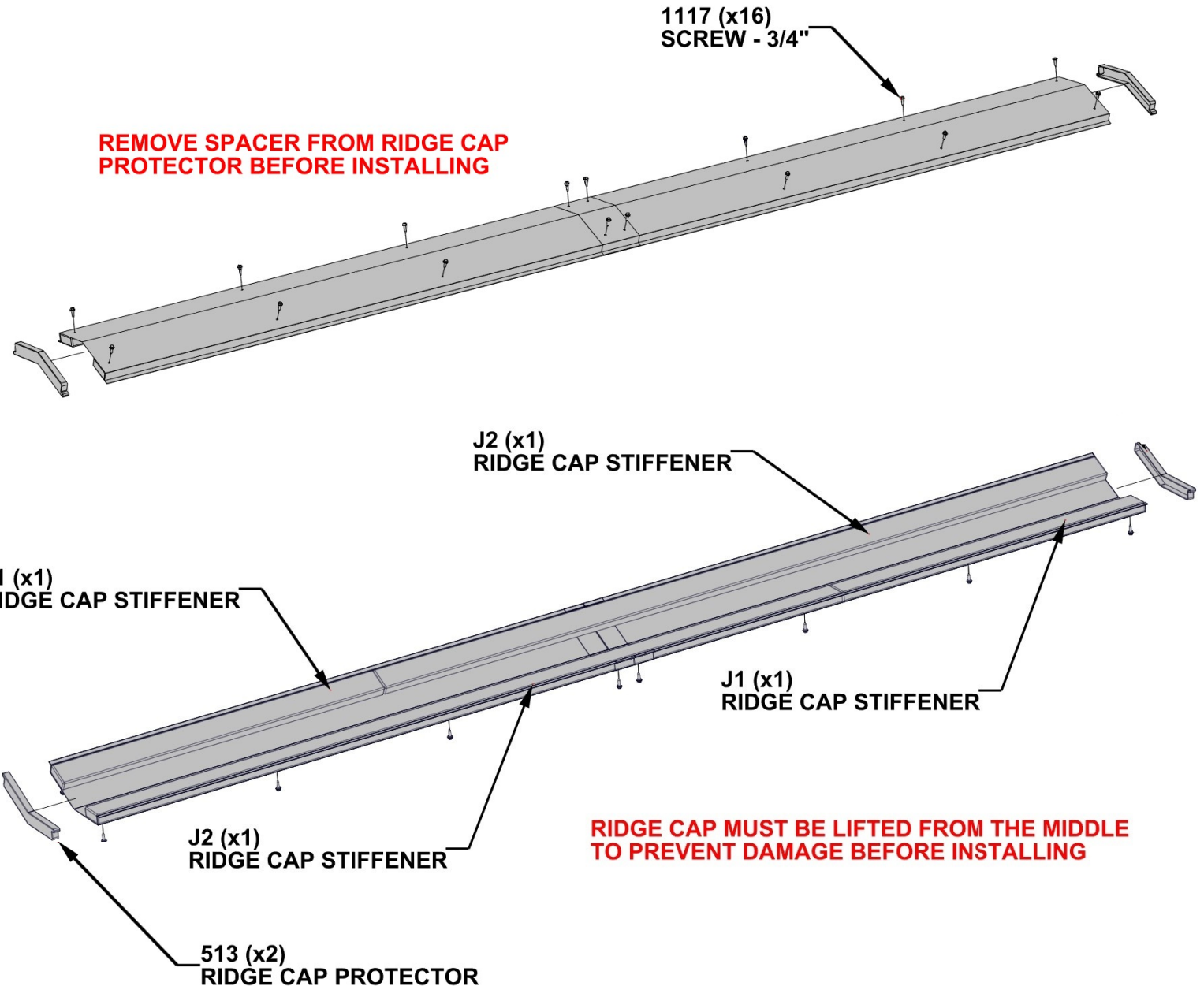

STEP 28B - GAZEBO ASSEMBLY

QTY	PART NUMBER	DESCRIPTION
4	H100395	SCREW PFH 8x3/4 BLK

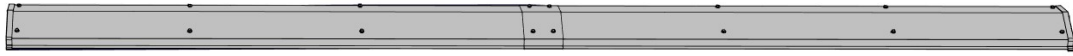

RIDGE CAP ASSEMBLY FROM PREVIOUS STEP

PRE-DRILL FOR EACH SCREW USING 1/8" 3mm DRILL BIT. LOCATE SCREWS APPROXIMATELY AS SHOWN. THEN REPEAT FOR OTHER END OF THE RIDGE CAP ASSEMBLY.

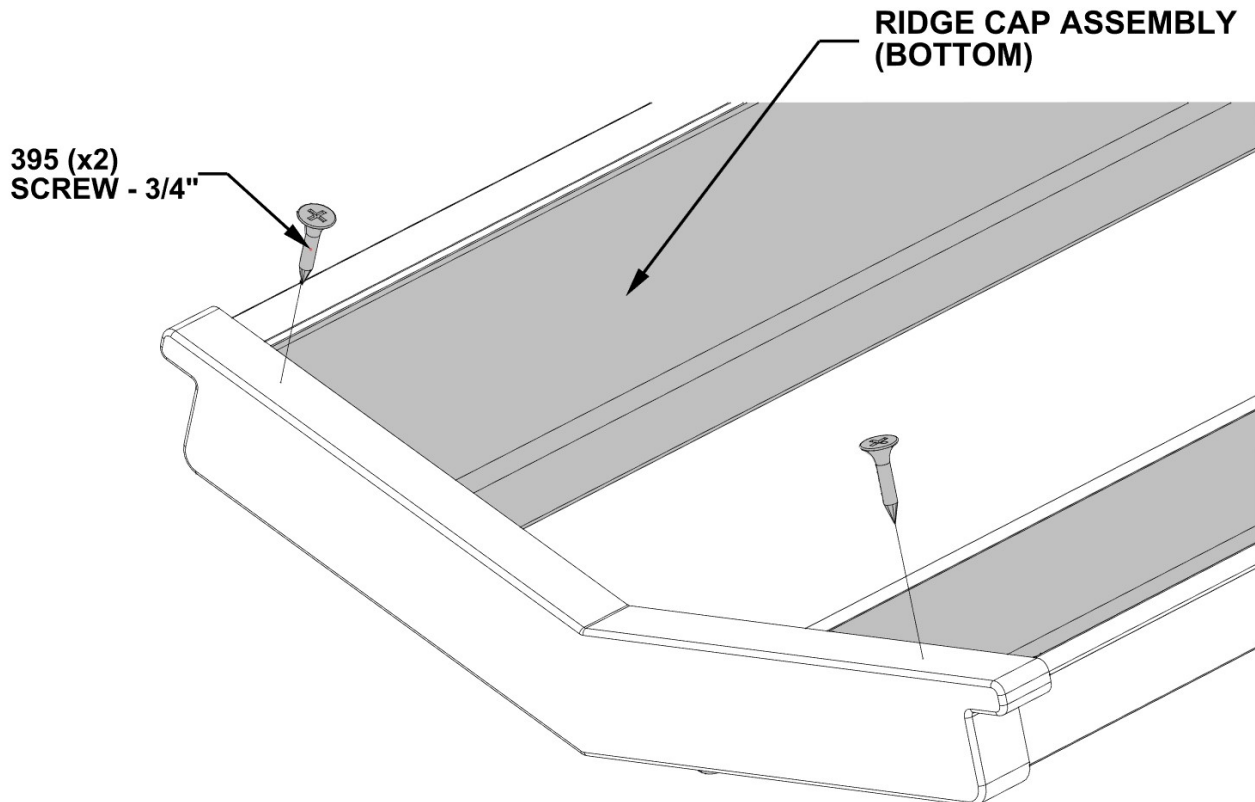
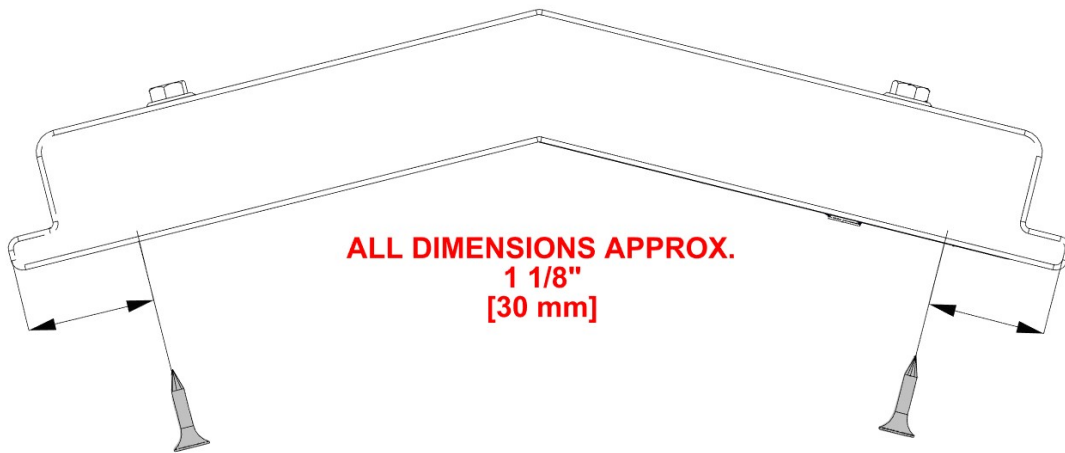

STEP 29 - GAZEBO ASSEMBLY

QTY	PART NUMBER	DESCRIPTION
16	H100392	SCREW PWH 8x3/4 BLK

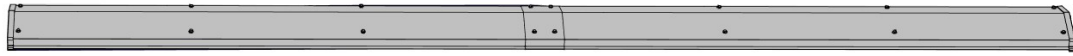

RIDGE CAP ASSEMBLY FROM PREVIOUS STEP

**DO NOT CLIMB ON ROOF TO INSTALL:
RIDGE CAP HAS BEEN DESIGNED TO
INSTALL WITH THE USE OF A LADDER.**

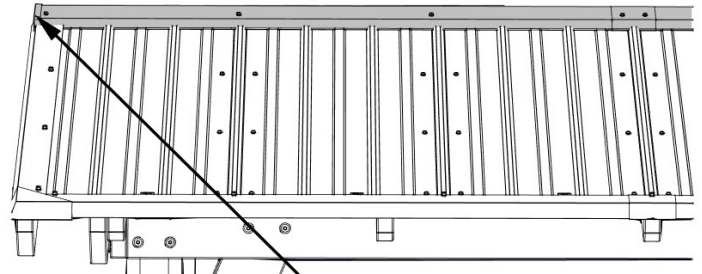
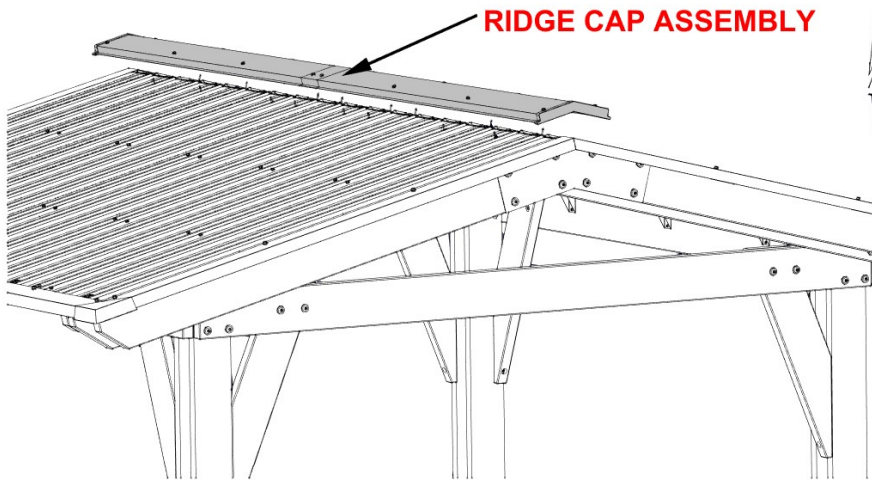

USING AN ADULT HELPER, SLIDE RIDGE CAP ASSEMBLY ACROSS THE ROOF RIDGE UNTIL BOTH ENDS ARE FLUSH WITH OUTSIDE EDGE.

FOR PROPER INSTALLATION, USE AN ADULT HELPER TO KEEP DOWNWARD PRESSURE ON THE RIDGE CAP WHILE SCREWING IN SCREWS.

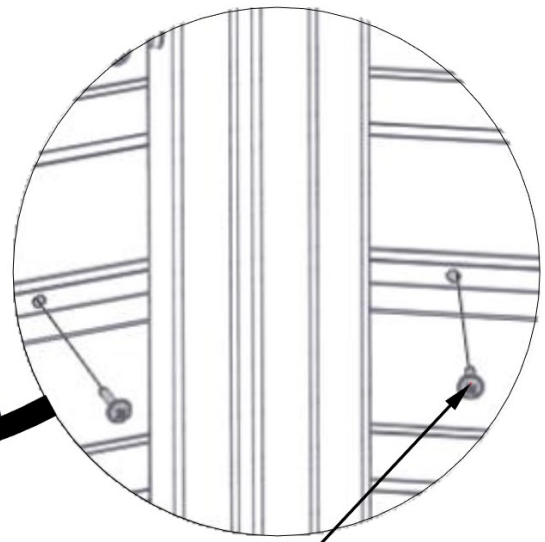
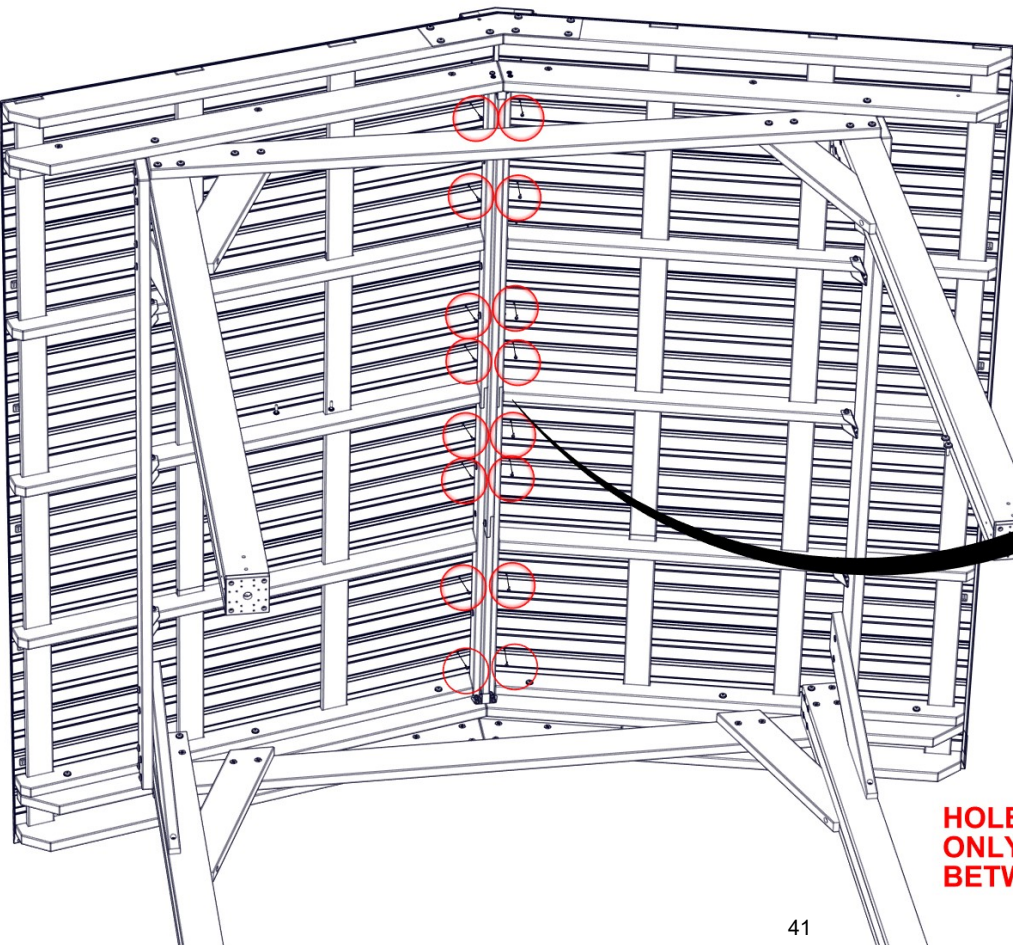

**392 (x16)
SCREW - 3/4"**

**HOLES CLOSE TO RAFTERS ARE NOT USED.
ONLY SCREW INTO HOLES CENTERED
BETWEEN RAFTERS LIKE SHOWN.**

STEP 30 - GAZEBO ASSEMBLY

QTY	PART NUMBER	DESCRIPTION
8	H100469	NUT BARREL WH 5/16X5/8 BLK
8	H100480	BOLT WH 5/16x4 3/4 BLK
16	H100471	LAG SCREW WH 5/16x1 1/2 BLK



A4M01477
(x8) | POST PLATE



A4M01478
(x8) | POST ANCHORING PLATE

NOTES:
477 POST PLATES MOUNT ON LEFT AND RIGHT SIDE OF POST.
478 ANCHORING PLATES MOUNT ON FRONT AND BACK OF POST.

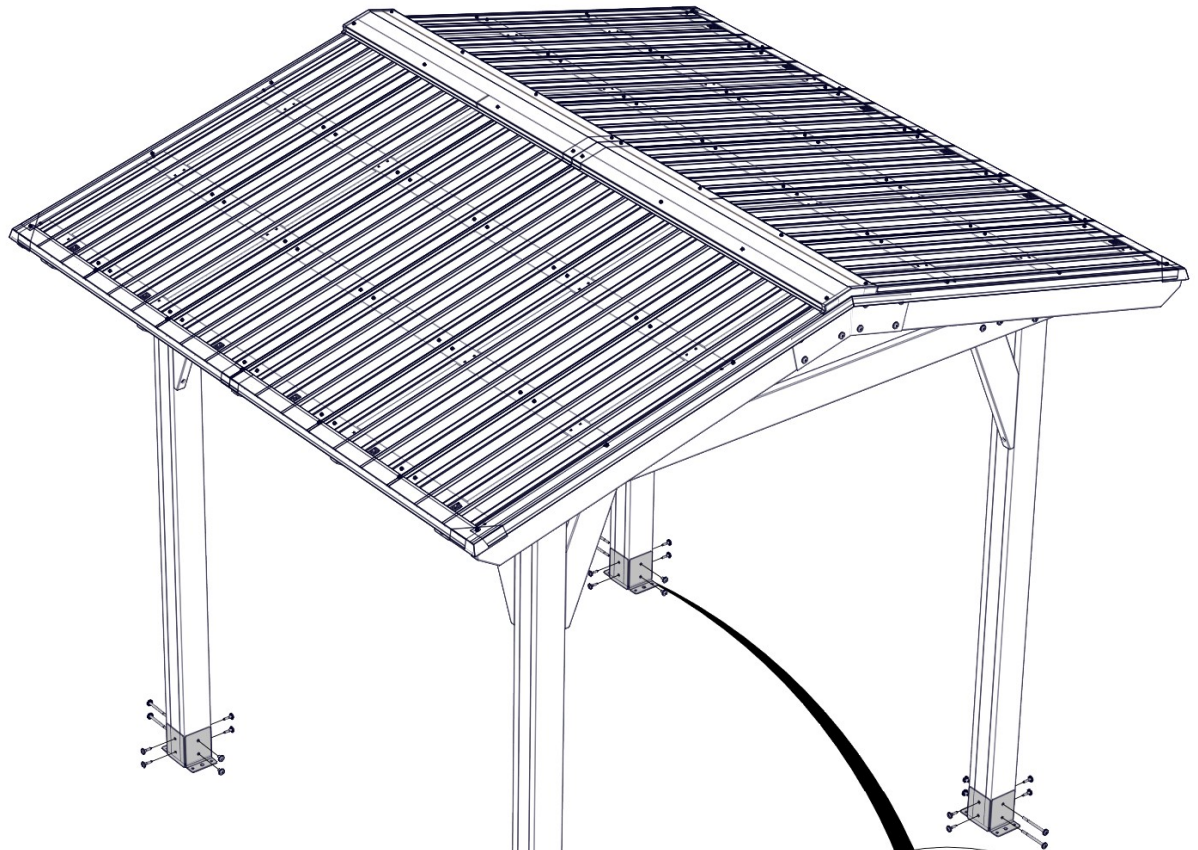

477 (x8)
POST PLATE

469 (x8)
BARREL NUT - 5/8"

480 (x8)
BOLT - 4 3/4"

478 (x8)
POST ANCHORING PLATE

471 (x16)
LAG SCREW - 1 1/2"

STEP 31 - GAZEBO ASSEMBLY



A100241
(x1) | BYD ID TAG (SMALL) WITHOUT AGES

QTY	PART NUMBER	DESCRIPTION
2	H100392	SCREW PWH 8x3/4 BLK

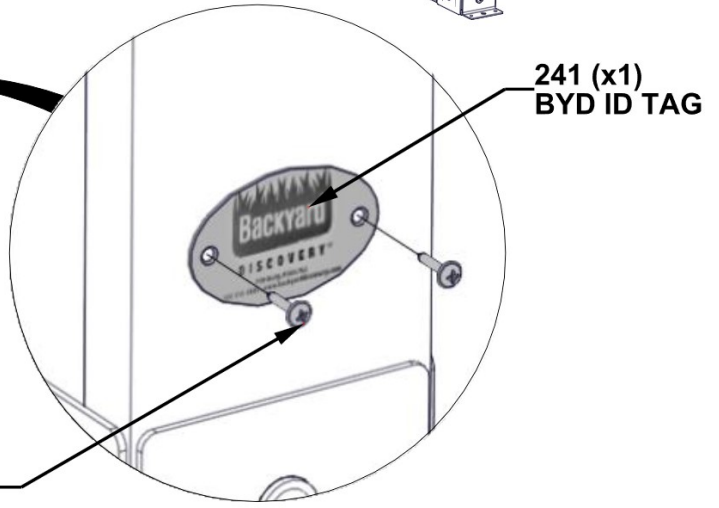
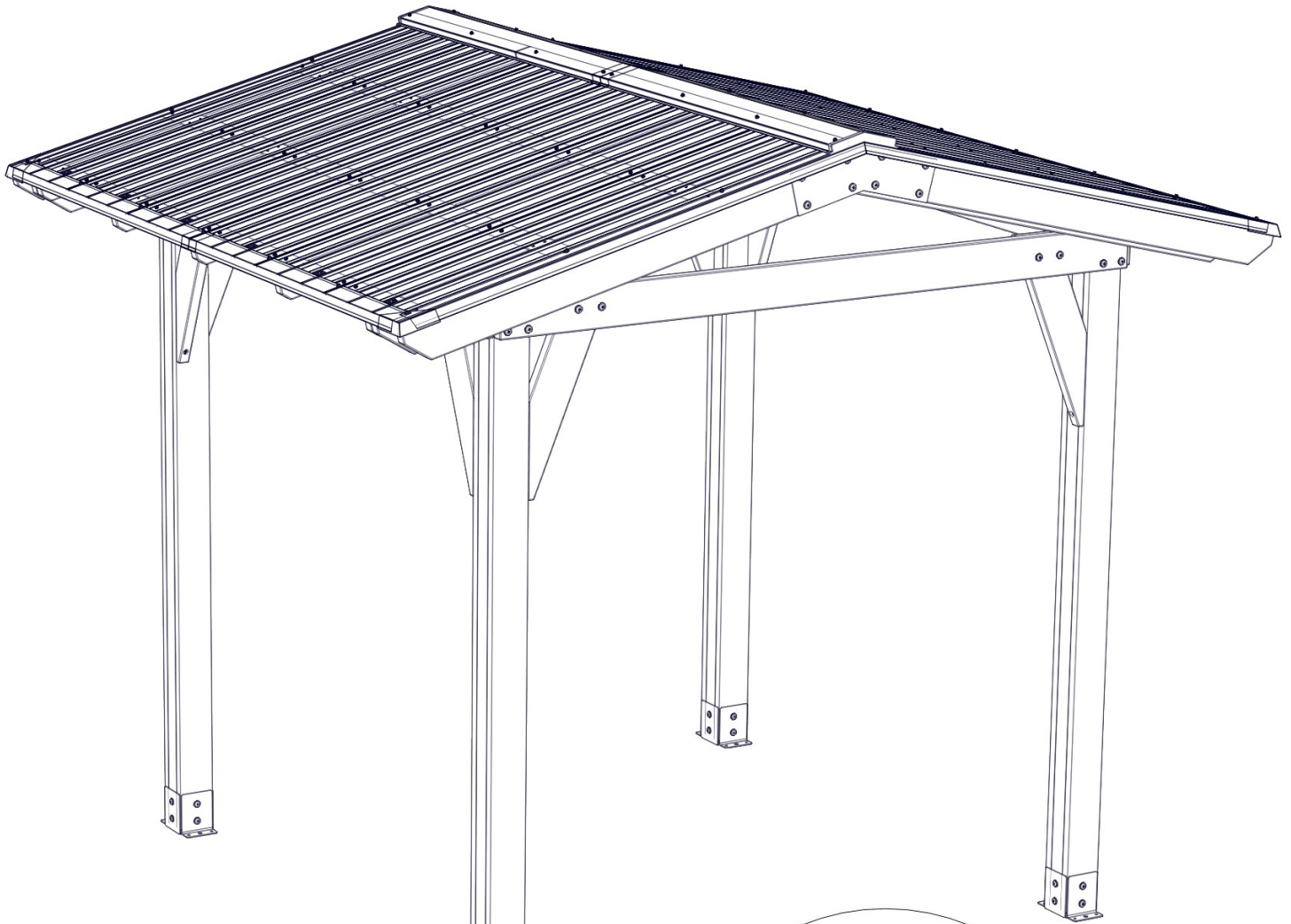

241 (x1)
BYD ID TAG

392 (x2)
SCREW - 3/4"

CUSTOMIZATION OF YOUR GRILL GAZEBO

STEP 1: CHOOSE TABLE CONFIGURATION

**ANGLE TABLE
CONFIGURATION**



**SPLIT TABLE
CONFIGURATION**



CUSTOMIZATION OF YOUR GRILL GAZEBO

STEP 2: CHOOSE TABLE SURFACE HEIGHT

STANDARD BAR
HEIGHT



STANDARD COUNTERTOP
HEIGHT



STEP 3A: CONSUMER DRILL TEMPLATE

USE TEMPLATE TO PRE-DRILL PILOT HOLES ON POST
(DON'T DRILL UNTIL STEP 3B)

- ALL PILOT HOLES SHOULD BE DRILLED USING A **6mm [1/4 in] DRILL BIT AT A DEPTH OF 15mm [5/8 in]**.
- USE FRONT SIDE OF TEMPLATE FOR STANDARD BAR HEIGHT OR BACK SIDE FOR STANDARD COUNTERTOP HEIGHT.
- MAKE SURE YOU ARE USING THE CORRECT DRILL TEMPLATE FOR YOUR SELECTED TABLE HEIGHT.
- PILOT HOLE TEMPLATE WILL REST DIRECTLY ON THE TOP EDGE OF THE METAL POST PLATE.

NOTE: DRILL TEMPLATE WILL BE USED MULTIPLE TIMES AND MUST BE RETAINED THROUGHOUT ENTIRE ASSEMBLY.

STANDARD BAR HEIGHT TEMPLATE

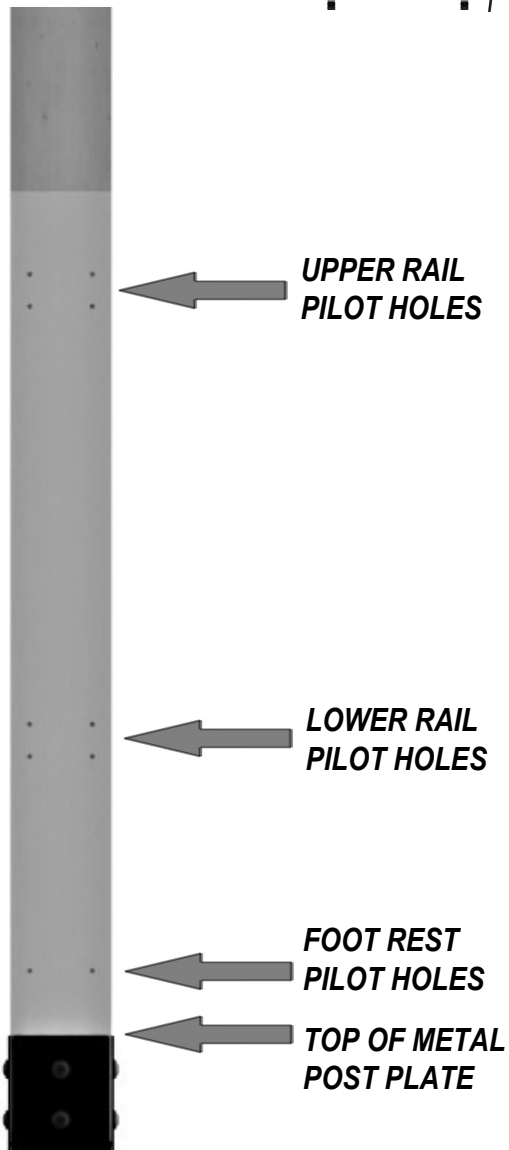

STANDARD COUNTERTOP HEIGHT TEMPLATE

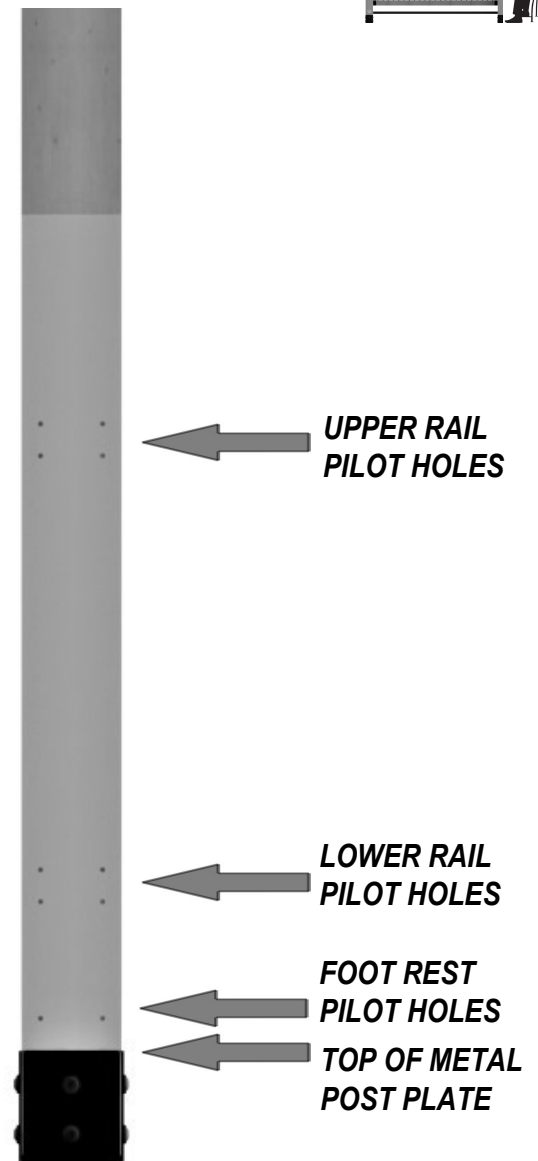

STEP 3B: CONSUMER DRILL TEMPLATE - AERIAL VIEW

- LOCATE DRILL DIAGRAM FOR THE CONFIGURATION OF YOUR CHOOSING BELOW.
- ALIGN DRILL TEMPLATE AT ARROW LOCATION ON SIDE OF POST OF YOUR CHOOSING. DRILL PILOT HOLES USING A **6mm [1/4 in] DRILL BIT AT A DEPTH OF 15mm [5/8 in]**. REPEAT FOR ALL ARROW LOCATIONS.

NOTE: ARROW ORIENTATION CAN BE OFF ANY POST FOR EACH CONFIGURATION.

ANGLE TABLE CONFIGURATION

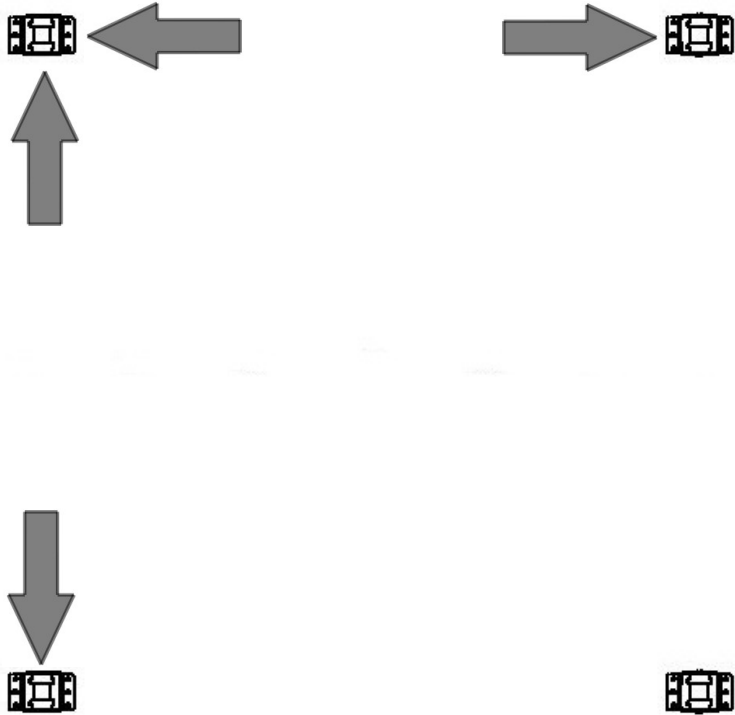

SPLIT TABLE CONFIGURATION

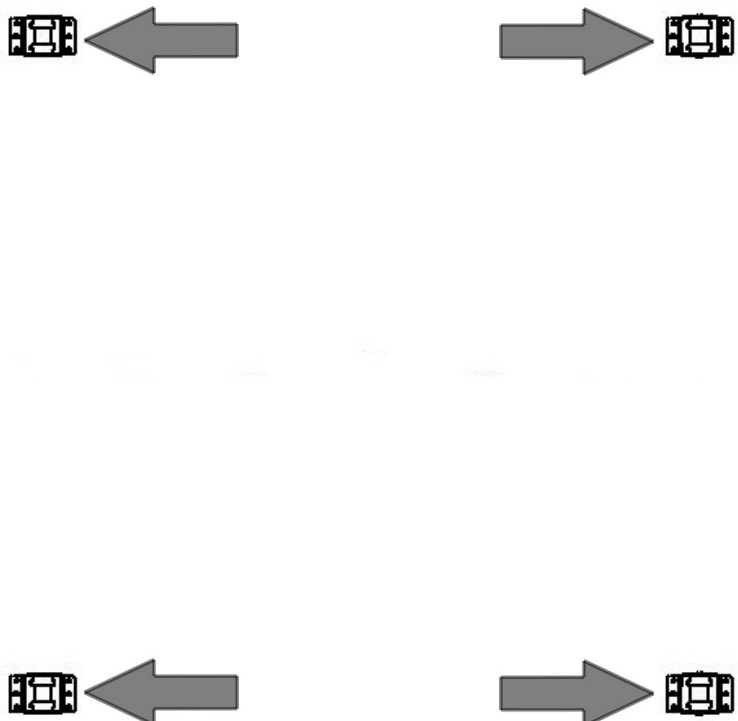

IF CHOOSING ANGLE TABLE CONFIGURATION, COMPLETE STEPS 4-22.



IF CHOOSING SPLIT TABLE CONFIGURATION, SKIP TO STEPS 23-37.



ANGLE TABLE CONFIGURATION

COMPLETE STEPS 4-22

NOTE: TABLE RAILS CAN BE ORIENTED OFF ANY POST.



STEP 4 - GAZEBO ASSEMBLY

(ASSEMBLY INSTRUCTION STEPS DEPICTS ANGLE TABLE CONFIGURATION)

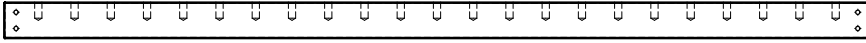

E1 | RAIL-W4L16362
(x2) | 1 7/16"x3 3/8"x80" (36x86x2032)



A4M00855 | L BRACKET
(x8) | 55x32x82x3.175

QTY	PART NUMBER	DESCRIPTION
8	H100469	NUT BARREL WH 5/16X5/8 BLK
8	H100459	BOLT WH 5/16x1 1/4 BLK

COMPLETE THIS STEP TWICE

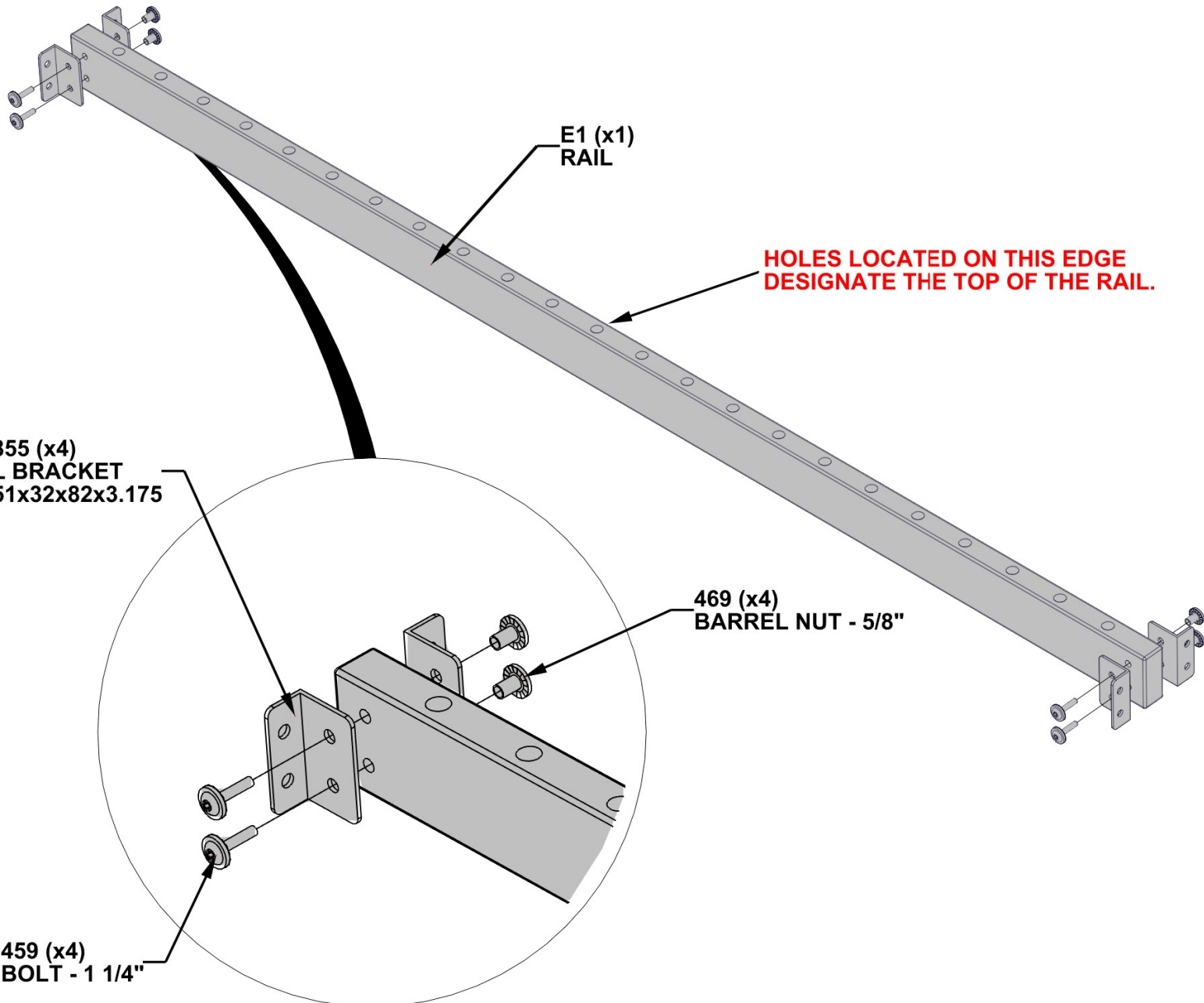

STEP 5 - GAZEBO ASSEMBLY

(ASSEMBLY INSTRUCTION STEPS DEPICTS ANGLE TABLE CONFIGURATION)

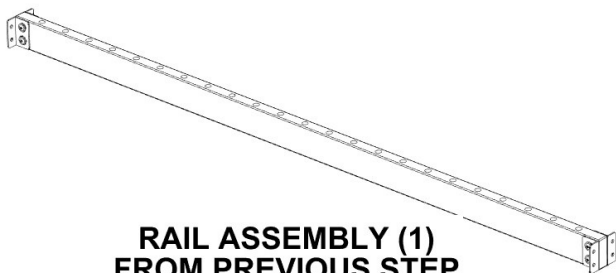

**RAIL ASSEMBLY (1)
FROM PREVIOUS STEP**

QTY	PART NUMBER	DESCRIPTION
8	H100854	LAG SCREW WH 5/16x1 BLK

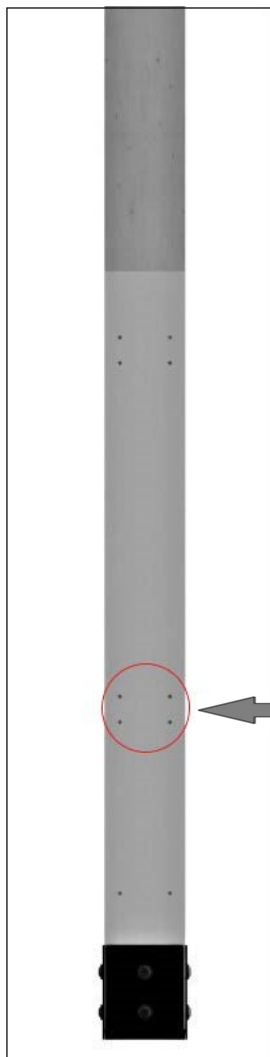

**LOWER RAIL
PILOT HOLES**

ALIGN RAIL ASSEMBLY FROM PREVIOUS STEP, WITH LOWER RAIL PILOT HOLES FROM CONSUMER DRILL TEMPLATE.

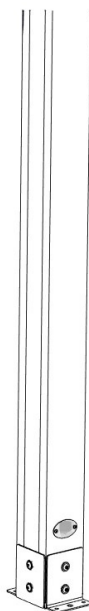
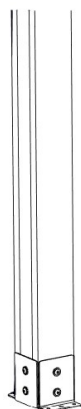

NOTE: HAND TIGHTEN LAG SCREWS TO POST

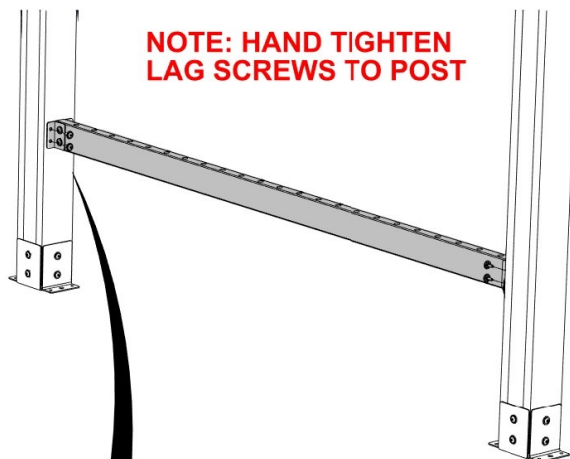

**854 (x8)
LAG SCREW - 1"**

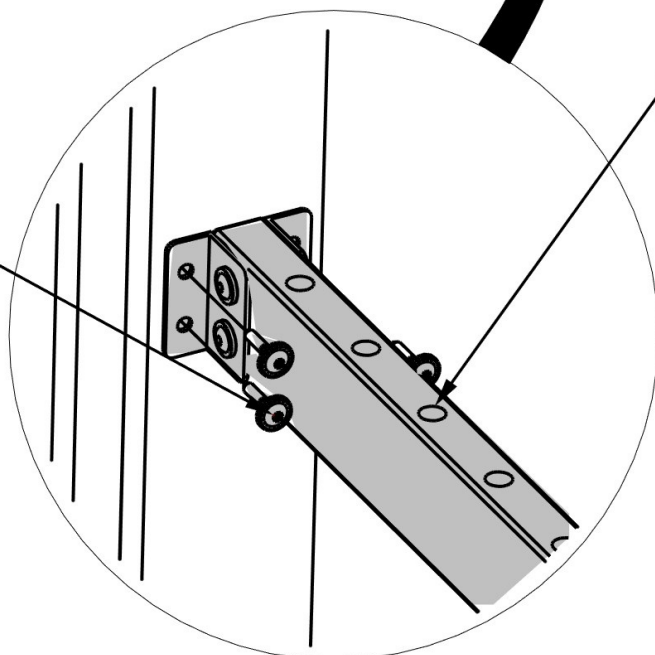

**NOTE:
HOLES IN RAIL FACE UP**

STEP 6 - GAZEBO ASSEMBLY

(ASSEMBLY INSTRUCTION STEPS DEPICTS ANGLE TABLE CONFIGURATION)

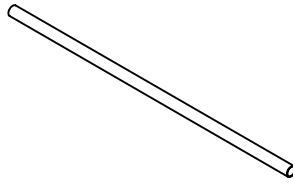

A4M01225
(x23) | METAL TUBE

PLACE METAL TUBES INTO BOTTOM BOARD OF RAIL ASSEMBLY

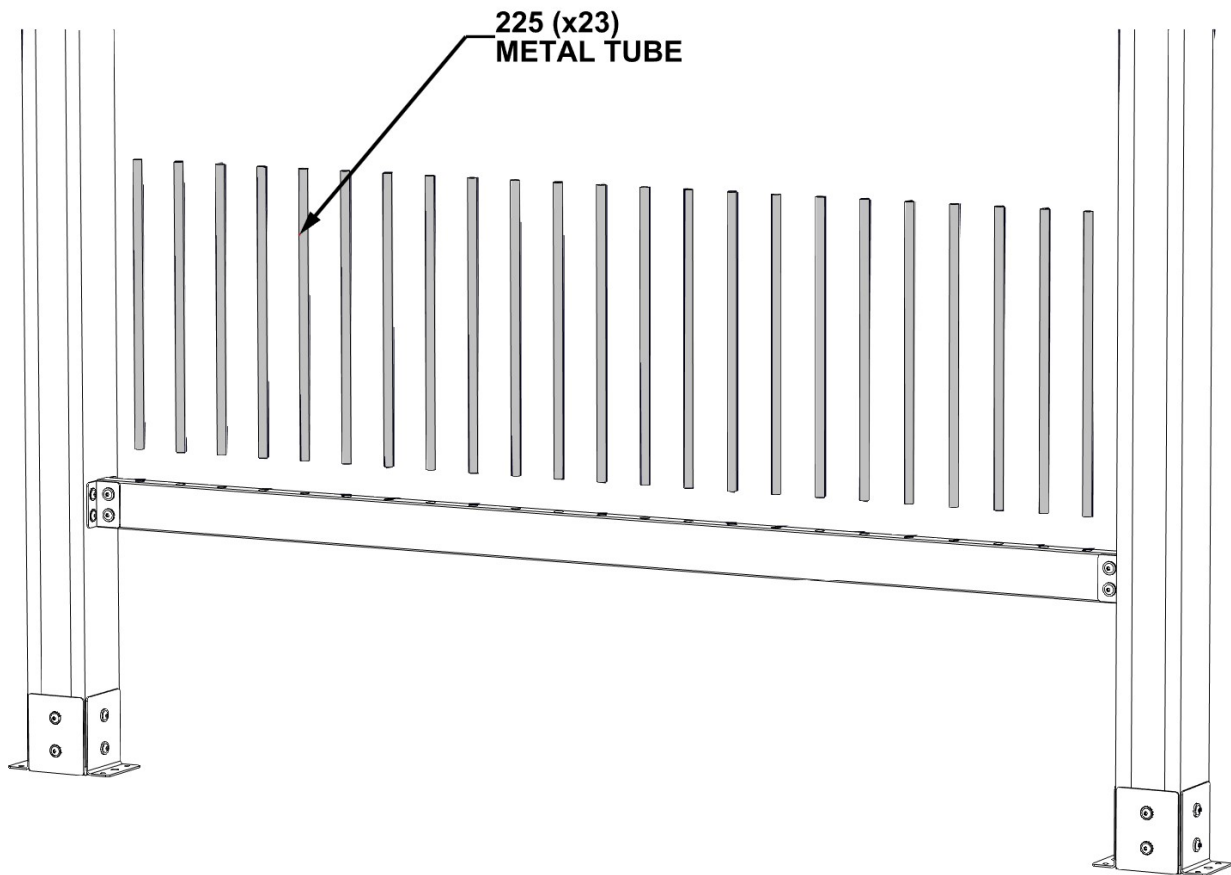

STEP 7 - GAZEBO ASSEMBLY

(ASSEMBLY INSTRUCTION STEPS DEPICTS ANGLE TABLE CONFIGURATION)

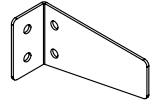

A4M00855 | L BRACKET
(x1) | 55x32x82x3.175

A4M01223 | L BRACKET
(x1)

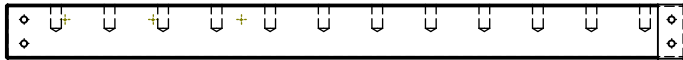

E2 | RAIL-W4L16363
(x1) | 1 7/16"x3 3/8"x42 7/16" (36x86x1078)

QTY	PART NUMBER	DESCRIPTION
2	H100469	NUT BARREL WH 5/16X5/8 BLK
2	H100459	BOLT WH 5/16x1 1/4 BLK
2	H100854	LAG SCREW WH 5/16x1 BLK

PLACE METAL TUBES INTO BOTTOM OF RAIL BOARD. ALIGN RAIL WITH UPPER RAIL PILOT HOLES FROM CONSUMER DRILL TEMPLATE.

UPPER RAIL PILOT HOLES

E2 (x1) RAIL

NOTE: LAP ORIENTATION

NOTE: FLAT SIDE OF BRACKET UP

469 (x2) BARREL NUT - 5/8"

223 (x1) L BRACKET

459 (x2) BOLT - 1 1/4"

854 (x2) LAG SCREW - 1"

855 (x1) L BRACKET 51x32x82x3.175

HAND TIGHTEN BOTTOM TWO LAG SCREWS ONLY. LEAVE LOOSE UNTIL TABLE TOP IS INSTALLED.

STEP 8 - GAZEBO ASSEMBLY

(ASSEMBLY INSTRUCTION STEPS DEPICTS ANGLE TABLE CONFIGURATION)

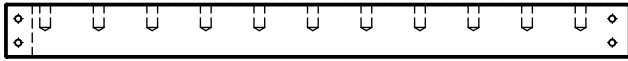

E3 | RAIL-W4L16364
(x1) | 1 7/16"x3 3/8"x39 1/8" (36x86x993)



A4M00855 | L BRACKET
(x1) | 55x32x82x3.175

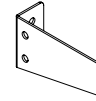

A4M01224
(x1) | L BRACKET

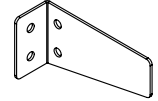

A4M01223
(x1) | L BRACKET

QTY	PART NUMBER	DESCRIPTION
2	H100379	T-NUT 5/16 BLK
2	H100459	BOLT WH 5/16x1 1/4 BLK
2	H100469	NUT BARREL WH 5/16X5/8 BLK
2	H100854	LAG SCREW WH 5/16x1 BLK
2	H100407	BOLT WH 5/16x1 1/2 BLK

**PLACE METAL TUBES INTO BOTTOM OF RAIL BOARD.
ALIGN RAIL WITH UPPER RAIL PILOT HOLES
FROM CONSUMER DRILL TEMPLATE.**

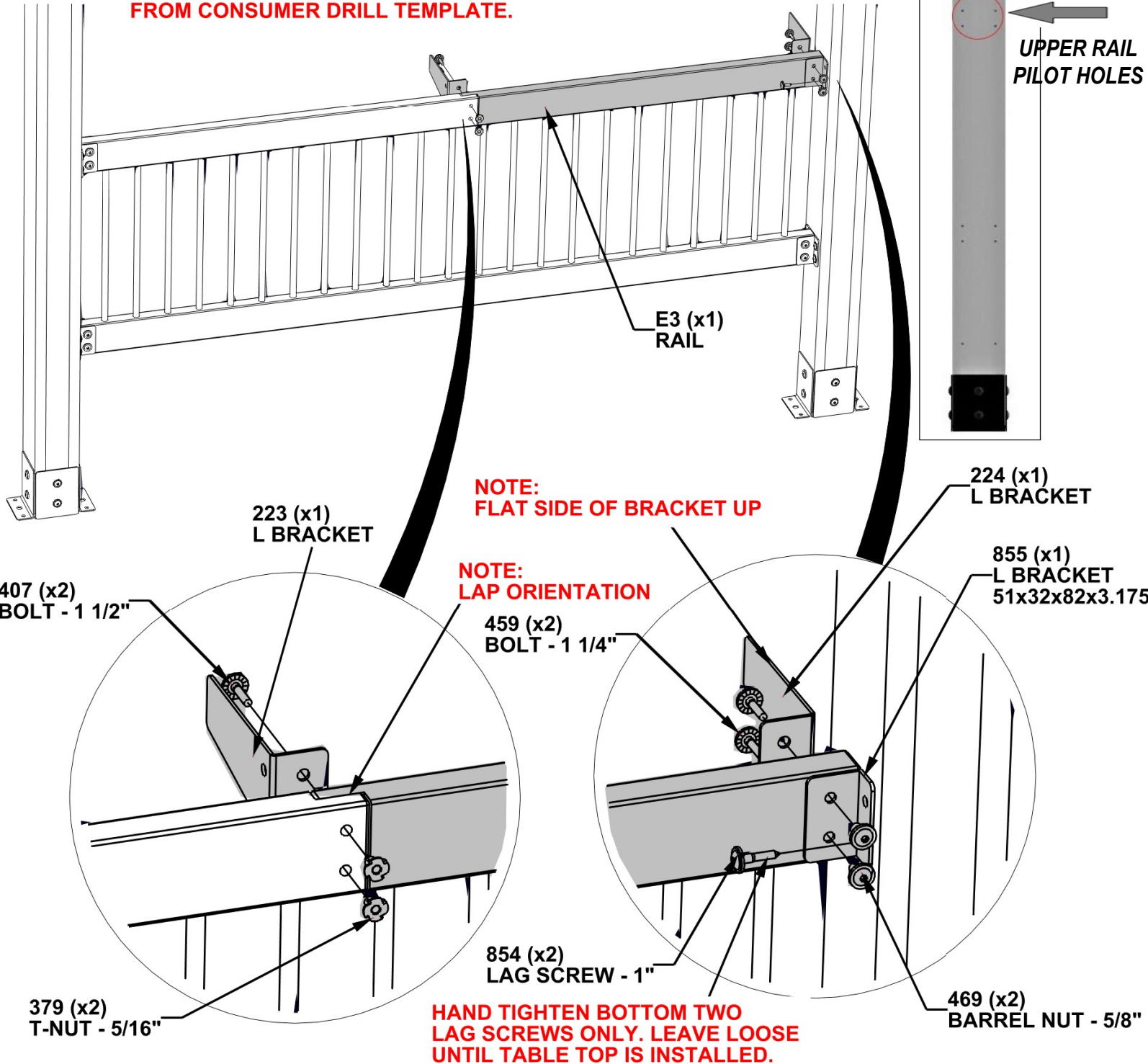

STEP 9 - GAZEBO ASSEMBLY

(ASSEMBLY INSTRUCTION STEPS DEPICTS ANGLE TABLE CONFIGURATION)

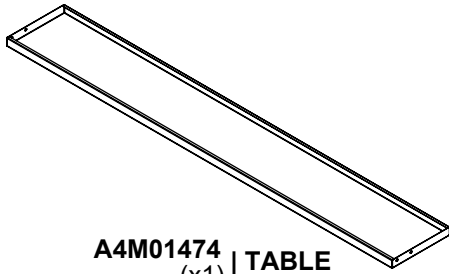

QTY	PART NUMBER	DESCRIPTION
4	H100854	LAG SCREW WH 5/16x1 BLK

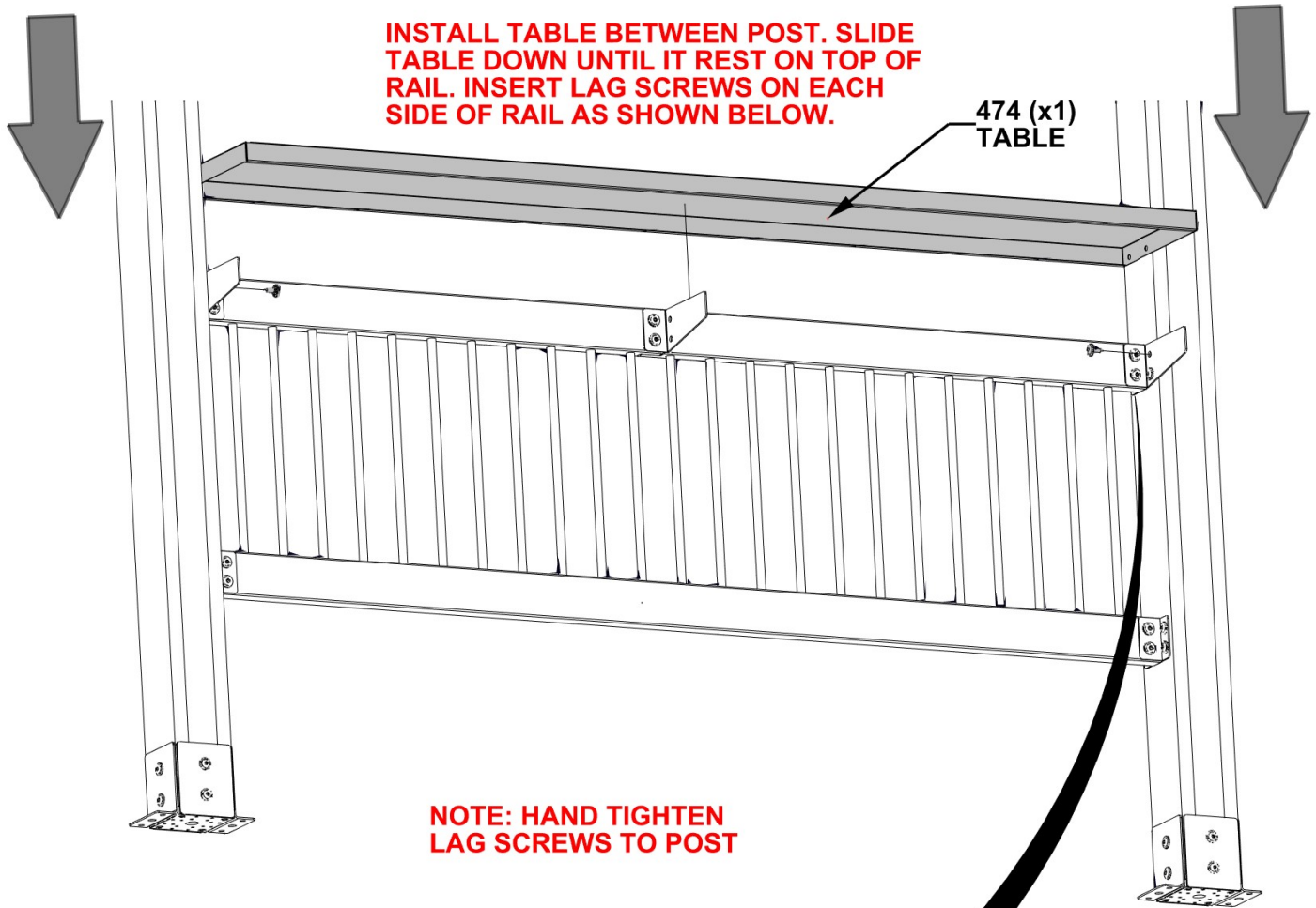

INSTALL TABLE BETWEEN POST. SLIDE TABLE DOWN UNTIL IT REST ON TOP OF RAIL. INSERT LAG SCREWS ON EACH SIDE OF RAIL AS SHOWN BELOW.

474 (x1) TABLE

NOTE: HAND TIGHTEN LAG SCREWS TO POST

HOLES IN TABLE SHOULD ALIGN WITH HOLES IN BRACKETS

854 (x4) LAG SCREW - 1"

STEP 10 - GAZEBO ASSEMBLY

(ASSEMBLY INSTRUCTION STEPS DEPICTS ANGLE TABLE CONFIGURATION)

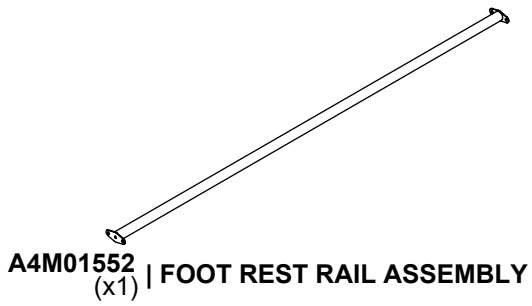

QTY	PART NUMBER	DESCRIPTION
4	H100854	LAG SCREW WH 5/16x1 BLK

ALIGN FOOT REST RAIL ASSEMBLY WITH BOTTOM TWO PILOT HOLES FROM CONSUMER DRILL TEMPLATE.

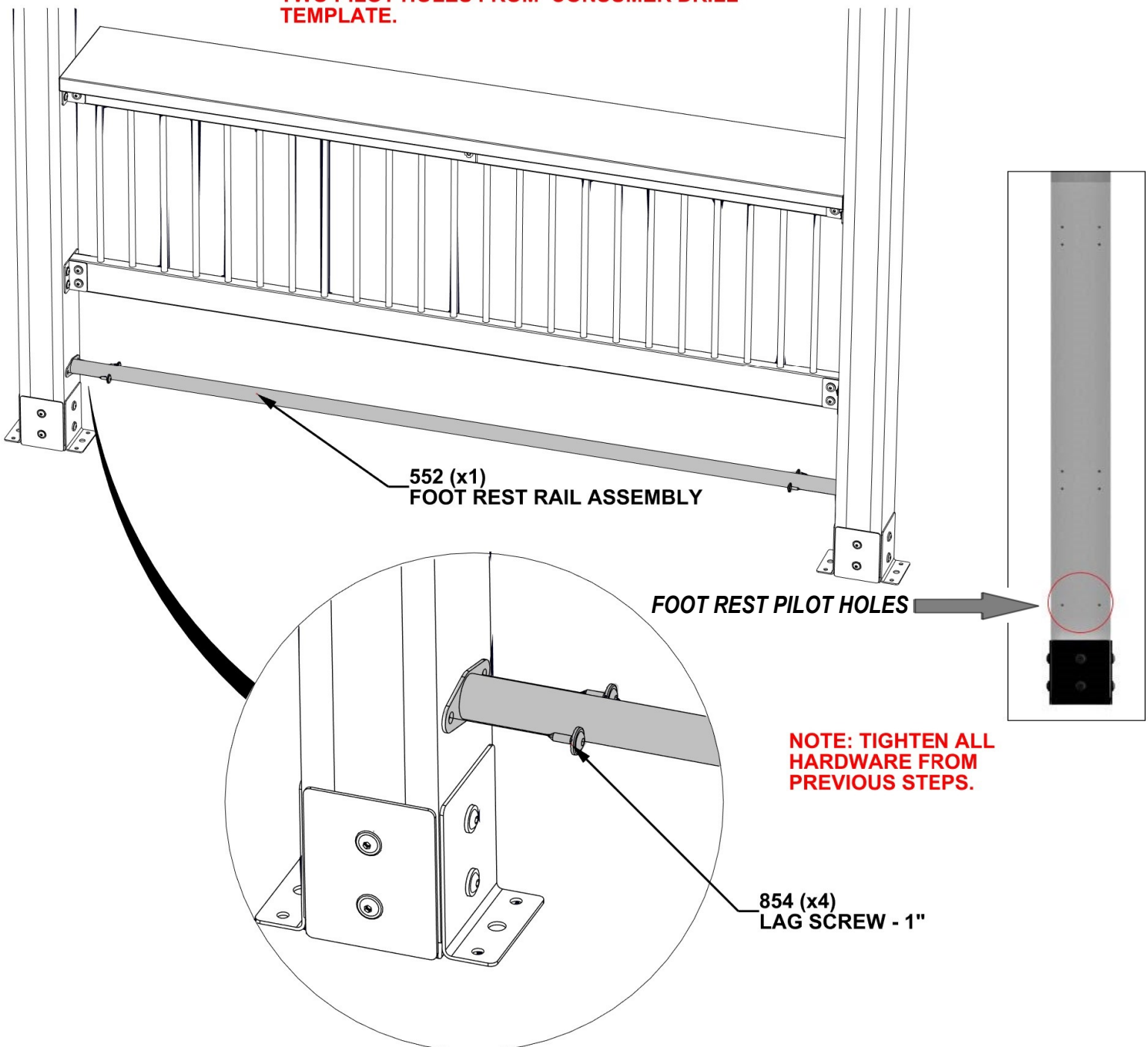

STEP 11 - GAZEBO ASSEMBLY

(ASSEMBLY INSTRUCTION STEPS DEPICTS ANGLE TABLE CONFIGURATION)

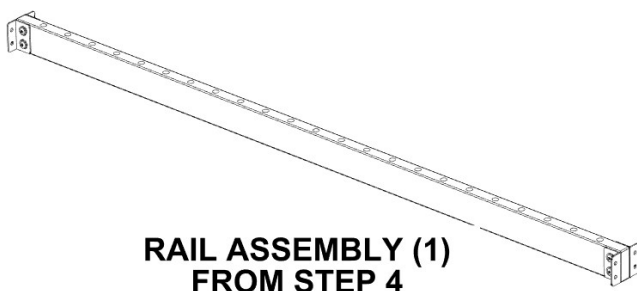

RAIL ASSEMBLY (1)
FROM STEP 4

QTY	PART NUMBER	DESCRIPTION
8	H100854	LAG SCREW WH 5/16x1 BLK

ALIGN RAIL ASSEMBLY FROM STEP 4,
WITH LOWER RAIL PILOT HOLES
FROM CONSUMER DRILL TEMPLATE.

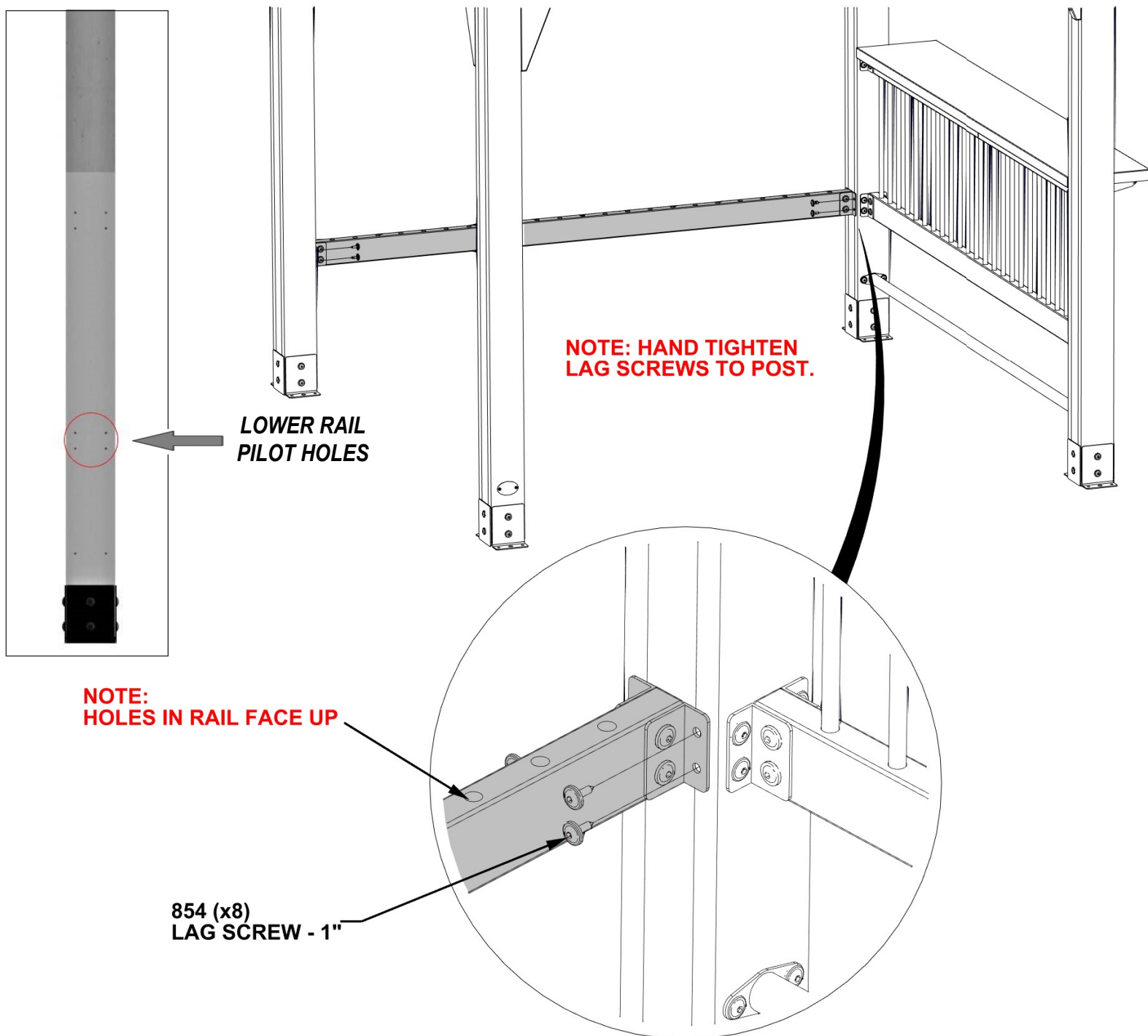

STEP 12 - GAZEBO ASSEMBLY

(ASSEMBLY INSTRUCTION STEPS DEPICTS ANGLE TABLE CONFIGURATION)

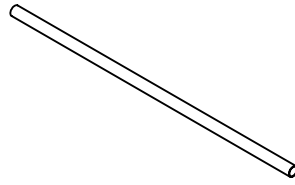

A4M01225
(x23) | METAL TUBE

PLACE METAL TUBES INTO BOTTOM BOARD OF RAIL ASSEMBLY

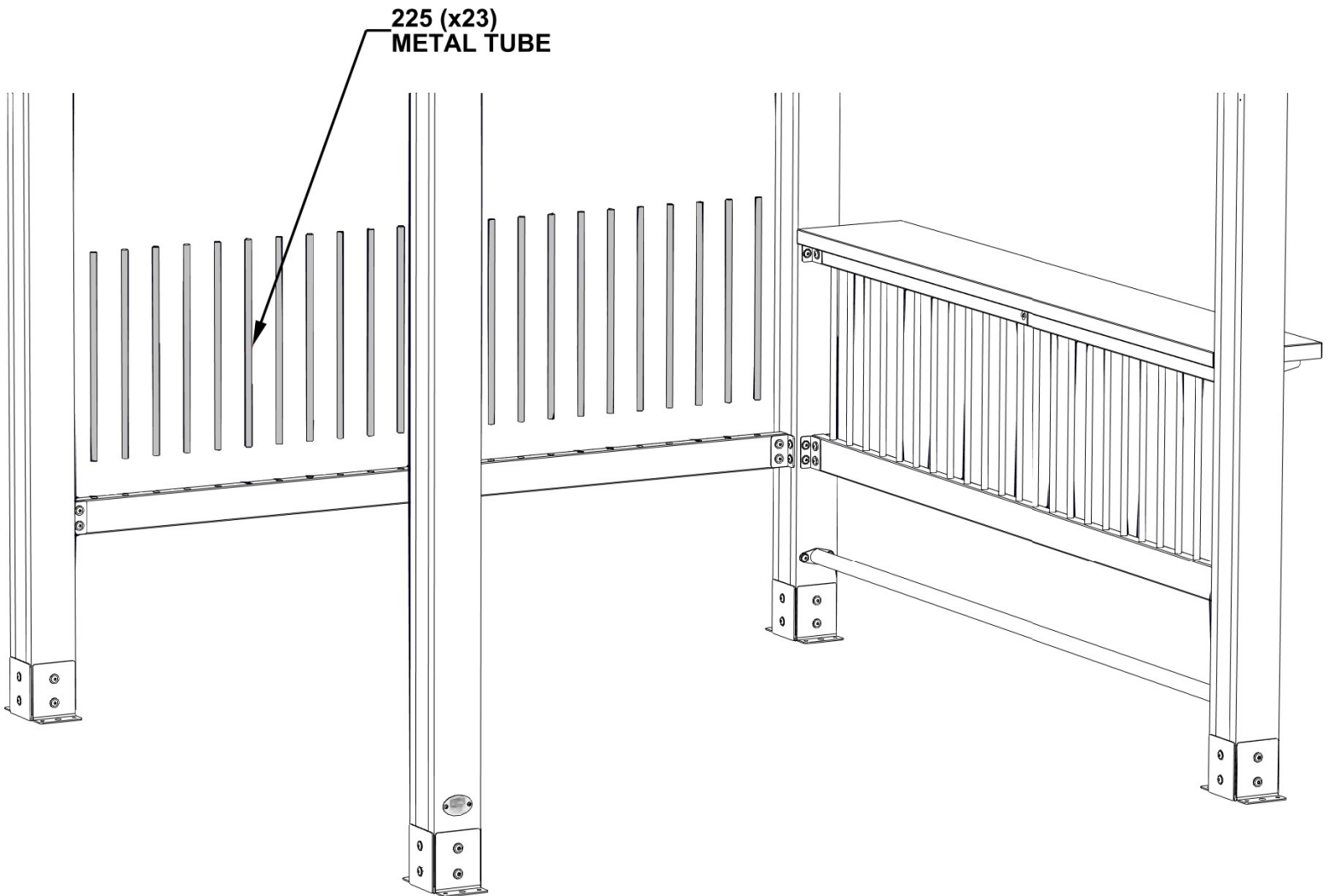

STEP 13 - GAZEBO ASSEMBLY

(ASSEMBLY INSTRUCTION STEPS DEPICTS ANGLE TABLE CONFIGURATION)

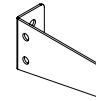

A4M01224
(x1) | L BRACKET

A4M00855 | L BRACKET
(x1) | 55x32x82x3.175

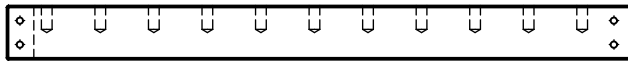

E3 | RAIL-W4L16364
(x1) | 1 7/16"x3 3/8"x39 1/8" (36x86x993)

QTY	PART NUMBER	DESCRIPTION
2	H100469	NUT BARREL WH 5/16X5/8 BLK
2	H100459	BOLT WH 5/16x1 1/4 BLK
2	H100854	LAG SCREW WH 5/16x1 BLK

PLACE METAL TUBES INTO BOTTOM OF RAIL BOARD.
ALIGN RAIL WITH UPPER RAIL PILOT HOLES FROM
CONSUMER DRILL TEMPLATE.

NOTE: FLAT SIDE OF BRACKET UP

855 (x1)
L BRACKET
51x32x82x3.175

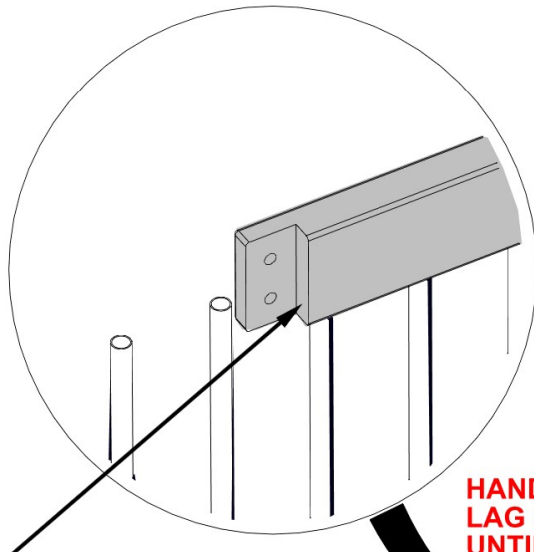

NOTE:
LAP ORIENTATION

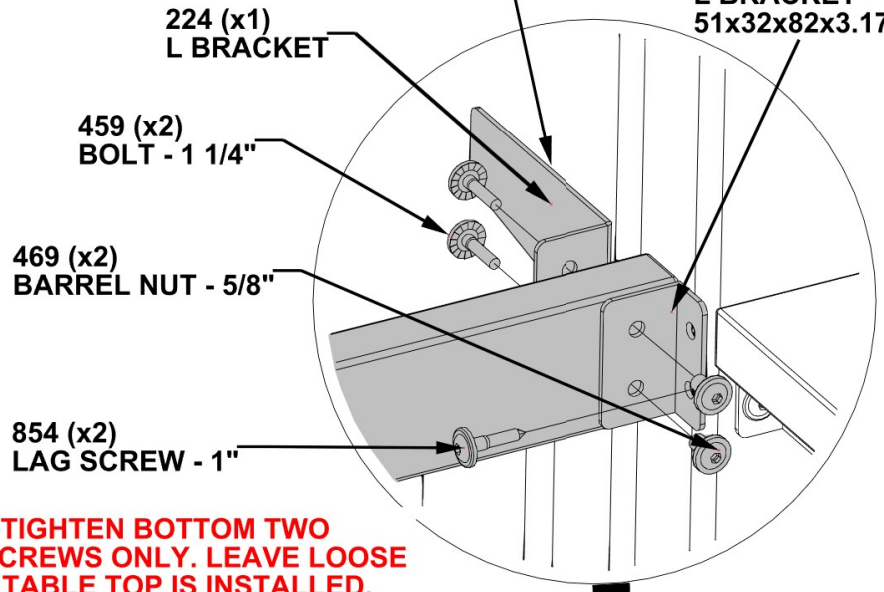

HAND TIGHTEN BOTTOM TWO
LAG SCREWS ONLY. LEAVE LOOSE
UNTIL TABLE TOP IS INSTALLED.

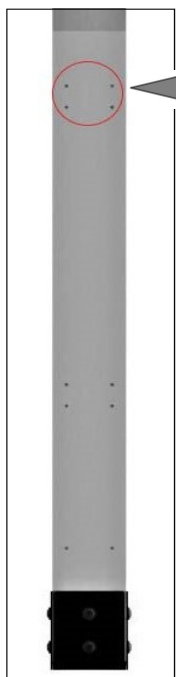

UPPER RAIL
PILOT HOLES

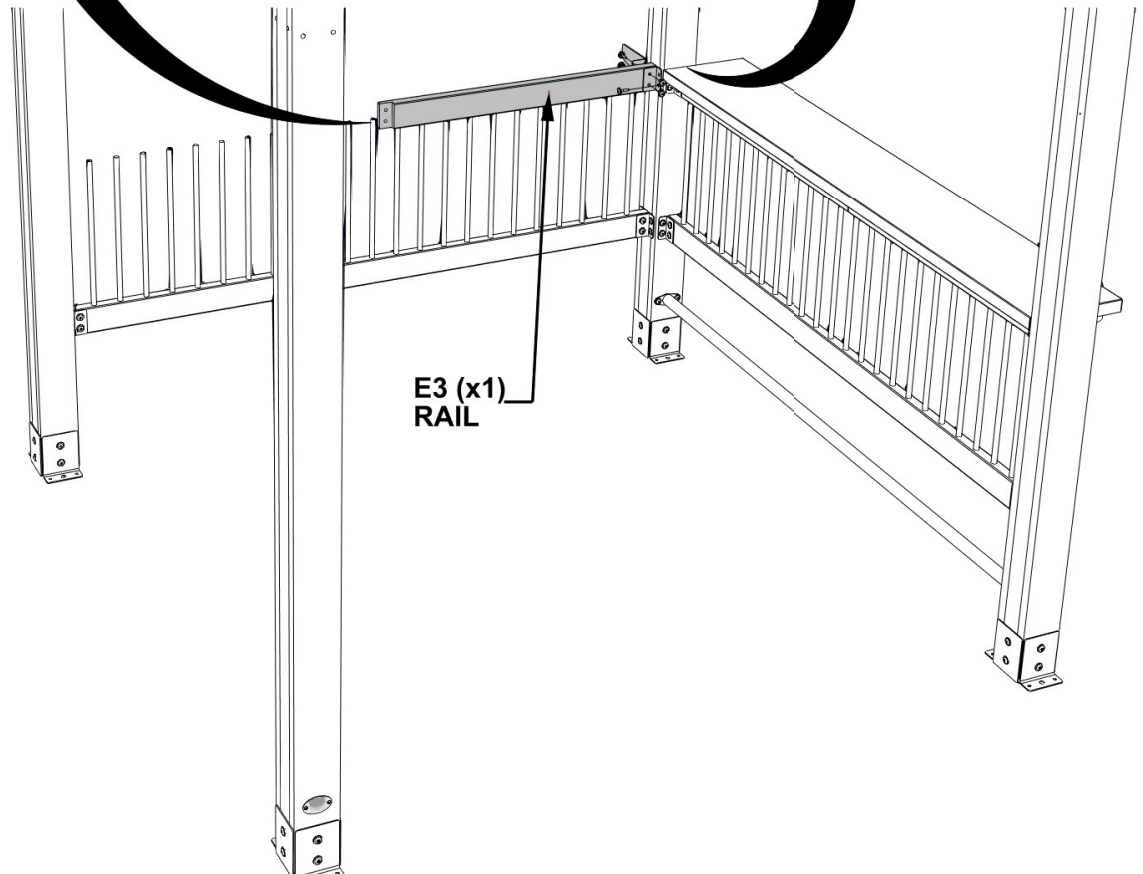

E3 (x1)
RAIL

STEP 14 - GAZEBO ASSEMBLY

(ASSEMBLY INSTRUCTION STEPS DEPICTS ANGLE TABLE CONFIGURATION)

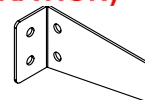

A4M00855 | L BRACKET
(x1) | 55x32x82x3.175

A4M01223 | L BRACKET
(x2)

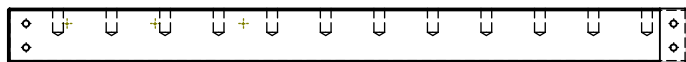

E2 | RAIL-W4L16363
(x1) | 1 7/16"x3 3/8"x42 7/16" (36x86x1078)

QTY	PART NUMBER	DESCRIPTION
2	H100459	BOLT WH 5/16x1 1/4 BLK
2	H100379	T-NUT 5/16 BLK
2	H100469	NUT BARREL WH 5/16X5/8 BLK
2	H100407	BOLT WH 5/16x1 1/2 BLK
2	H100854	LAG SCREW WH 5/16x1 BLK

PLACE METAL TUBES INTO BOTTOM OF RAIL BOARD. ALIGN RAIL WITH UPPER RAIL PILOT HOLES FROM CONSUMER DRILL TEMPLATE.

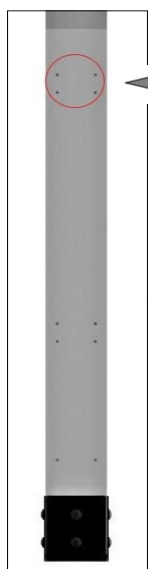

UPPER RAIL PILOT HOLES

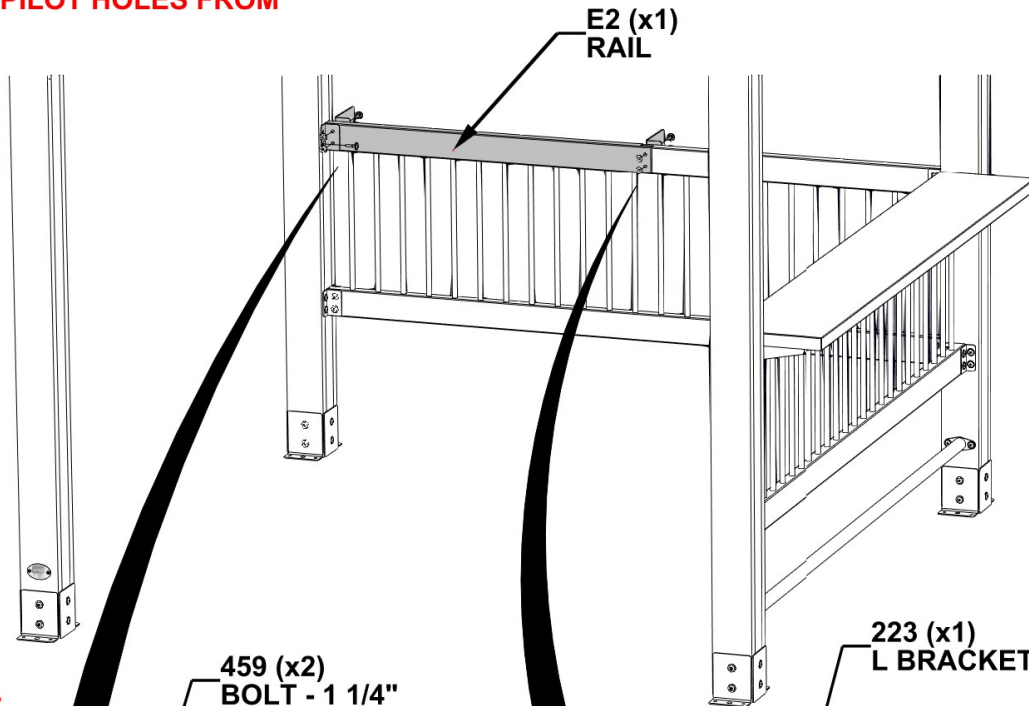

E2 (x1) RAIL

NOTE: FLAT SIDE OF BRACKET UP.

459 (x2) BOLT - 1 1/4"

NOTE: LAP ORIENTATION

223 (x1) L BRACKET

407 (x2) BOLT - 1 1/2"

223 (x1) L BRACKET

855 (x1) L BRACKET 51x32x82x3.175

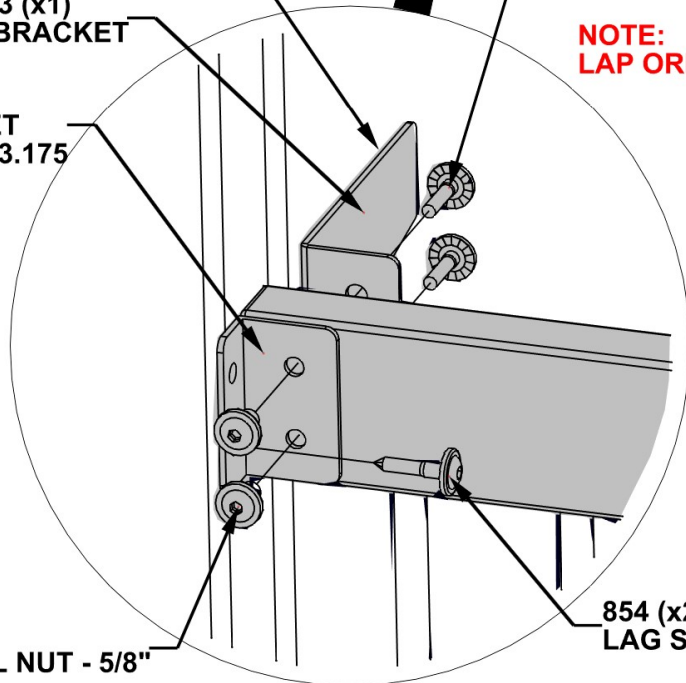

469 (x2) BARREL NUT - 5/8"

854 (x2) LAG SCREW - 1"

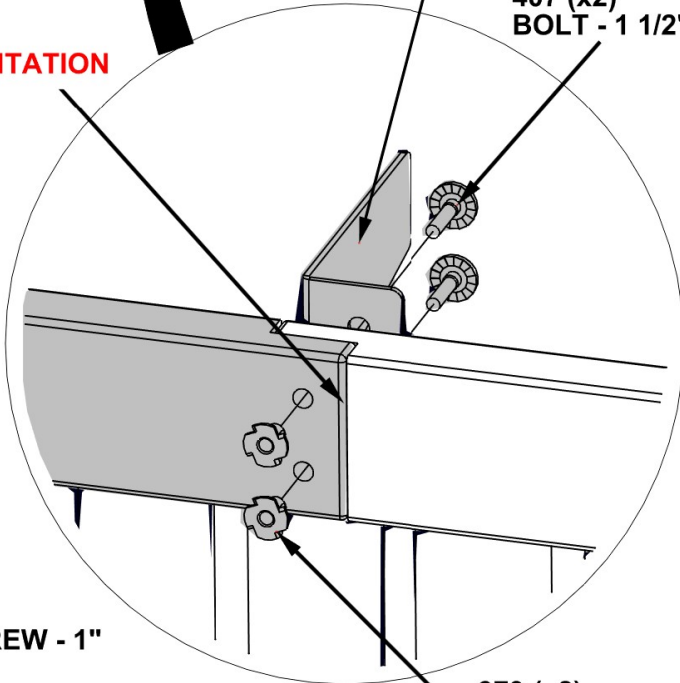

379 (x2) T-NUT - 5/16"

HAND TIGHTEN BOTTOM TWO LAG SCREWS ONLY. LEAVE LOOSE UNTIL TABLE TOP IS INSTALLED.

STEP 15 - GAZEBO ASSEMBLY

(ASSEMBLY INSTRUCTION STEPS DEPICTS ANGLE TABLE CONFIGURATION)

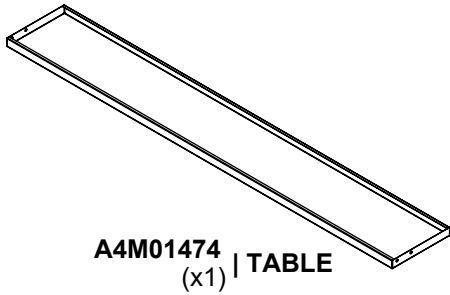

QTY	PART NUMBER	DESCRIPTION
4	H100854	LAG SCREW WH 5/16x1 BLK

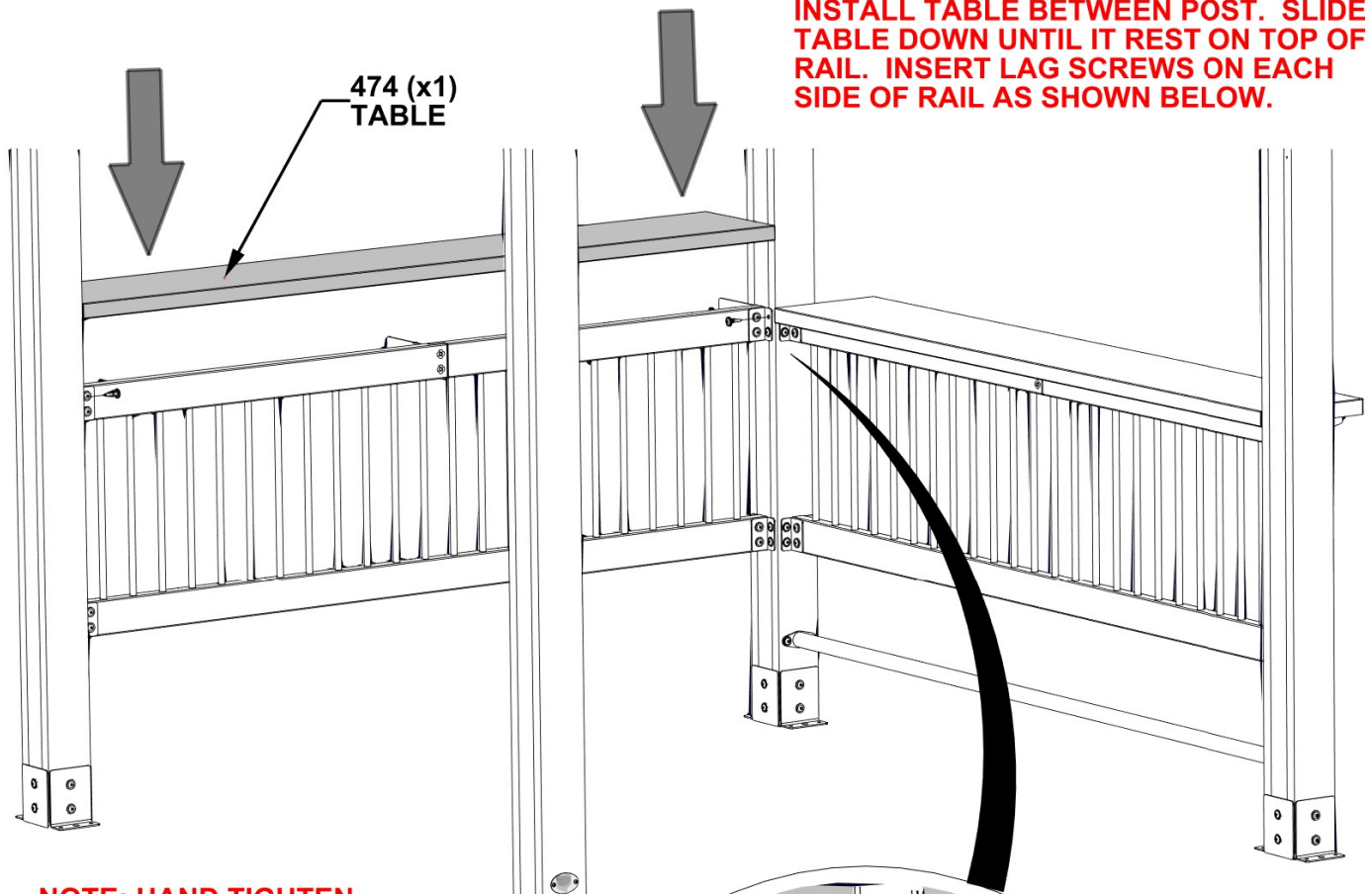

NOTE: HAND TIGHTEN LAG SCREWS TO POST.

HOLES IN TABLE SHOULD ALIGN WITH HOLES IN BRACKETS

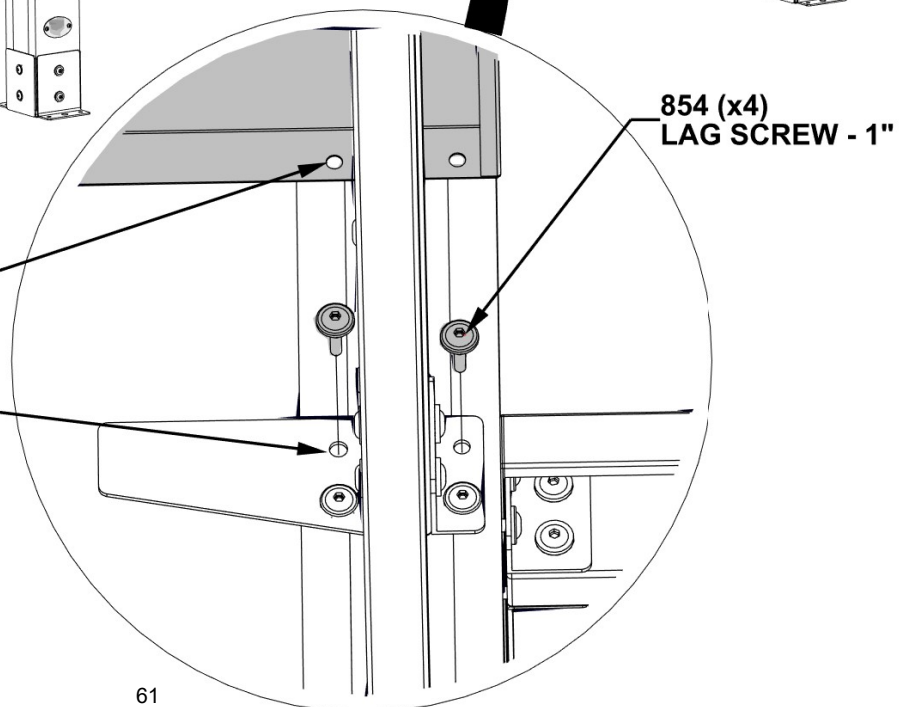

STEP 16 - GAZEBO ASSEMBLY

(ASSEMBLY INSTRUCTION STEPS DEPICTS ANGLE TABLE CONFIGURATION)

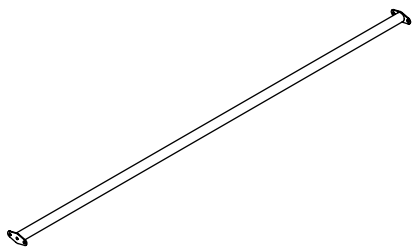

QTY	PART NUMBER	DESCRIPTION
4	H100854	LAG SCREW WH 5/16x1 BLK

A4M01552 (x1) | FOOT REST RAIL ASSEMBLY

ALIGN FOOT REST RAIL ASSEMBLY WITH BOTTOM TWO PILOT HOLES FROM CONSUMER DRILL TEMPLATE.

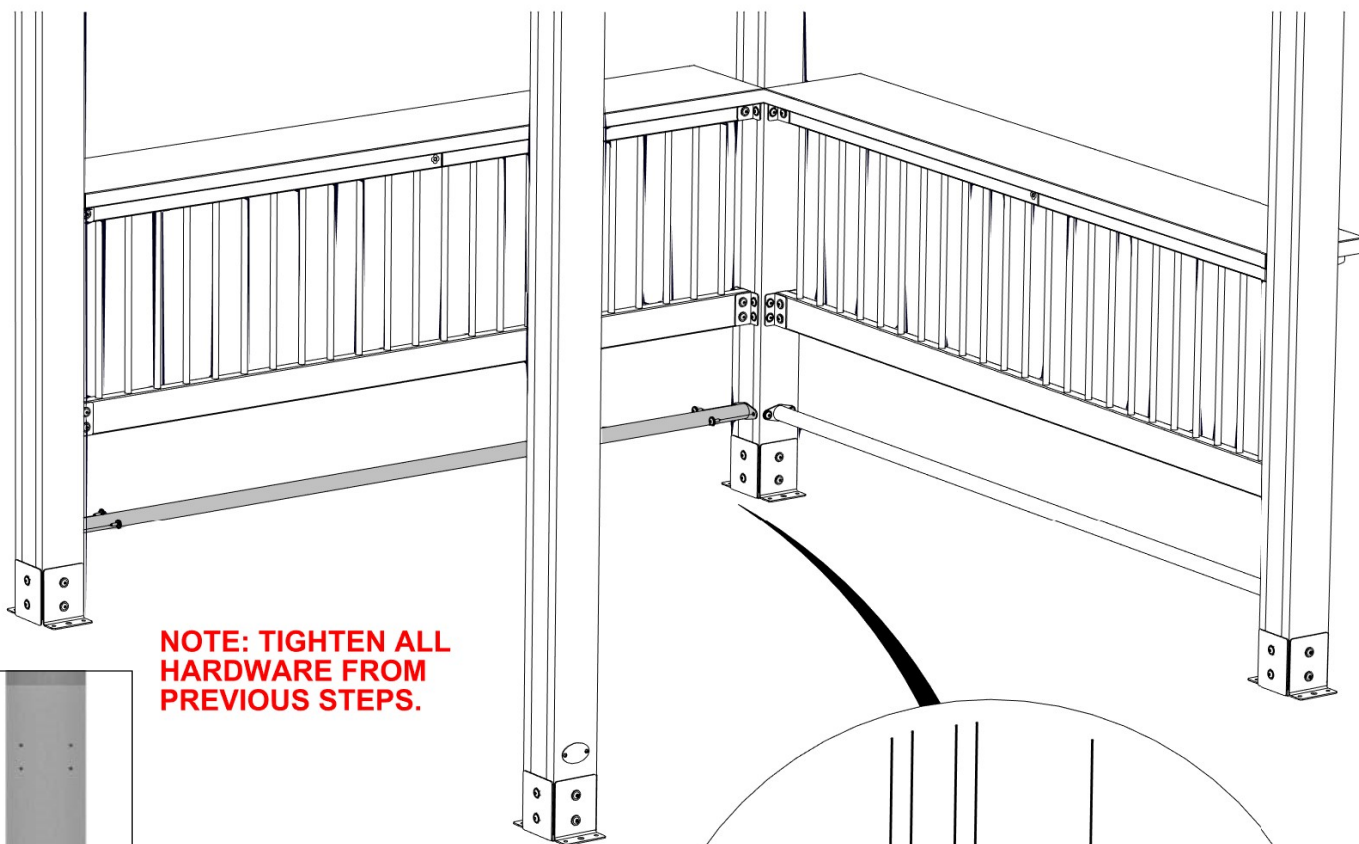

NOTE: TIGHTEN ALL HARDWARE FROM PREVIOUS STEPS.

552 (x1)
FOOT REST RAIL ASSEMBLY

854 (x4)
LAG SCREW - 1"

FOOT REST PILOT HOLES

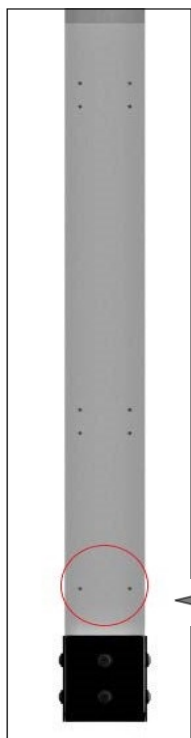

STEP 17 - GAZEBO ASSEMBLY

(ASSEMBLY INSTRUCTION STEPS DEPICTS ANGLE TABLE CONFIGURATION)

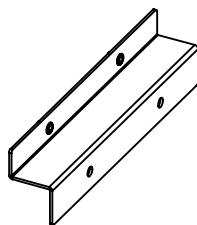

A4M01662 | TABLE BRACKET W/ INSERTS
(x2) | (ANGLE CONFIGURATION ONLY)

NOTES:

1. PLACE TABLE BRACKETS IN CORNER, CLOSEST TO POST.
2. USE TABLE BRACKET AS A DRILL TEMPLATE FOR CORNER TABLE.
3. ALIGN TABLE BRACKET, FLUSH WITH BOTTOM OF RAIL.
4. ALIGN SIDE OF TABLE BRACKET AGAINST SIDE OF L BRACKET.
5. DRILL #10 [3/8 in] THRU HOLE, 2 PLACES FOR EACH BRACKET.

662 (x2)
TABLE BRACKET
W/ INSERTS



BRACKET AGAINST
EDGE

BOTTOM OF TABLE BRACKET
FLUSH WITH BOTTOM OF RAIL

#10 THRU HOLE [3/8 in]
2 PLACES EACH BRACKET

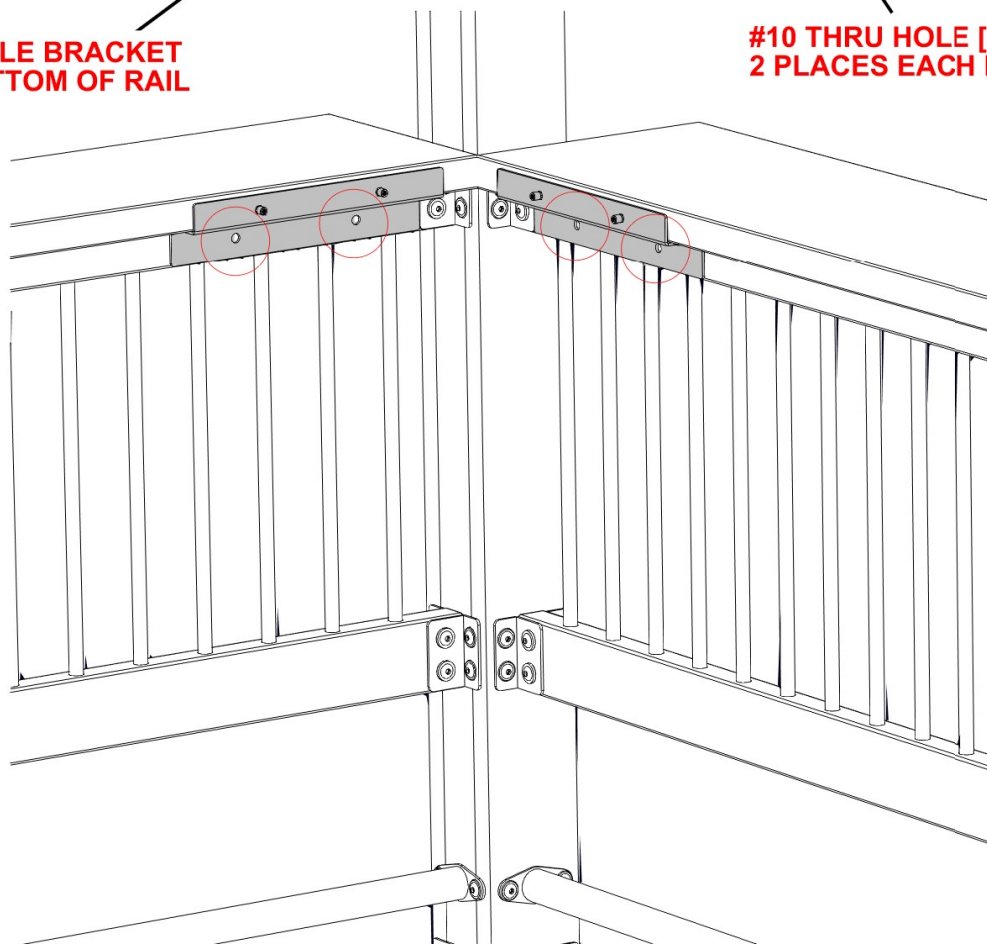

STEP 18 - GAZEBO ASSEMBLY

(ASSEMBLY INSTRUCTION STEPS DEPICTS ANGLE TABLE CONFIGURATION)

QTY	PART NUMBER	DESCRIPTION
4	H100469	NUT BARREL WH 5/16X5/8 BLK
4	H100459	BOLT WH 5/16x1 1/4 BLK
4	H100198	WASHER LOCK EXT 8x19

INSTALL TABLE BRACKETS AS SHOWN BELOW ALIGNING WITH CONSUMER DRILLED HOLES FROM PREVIOUS STEP.

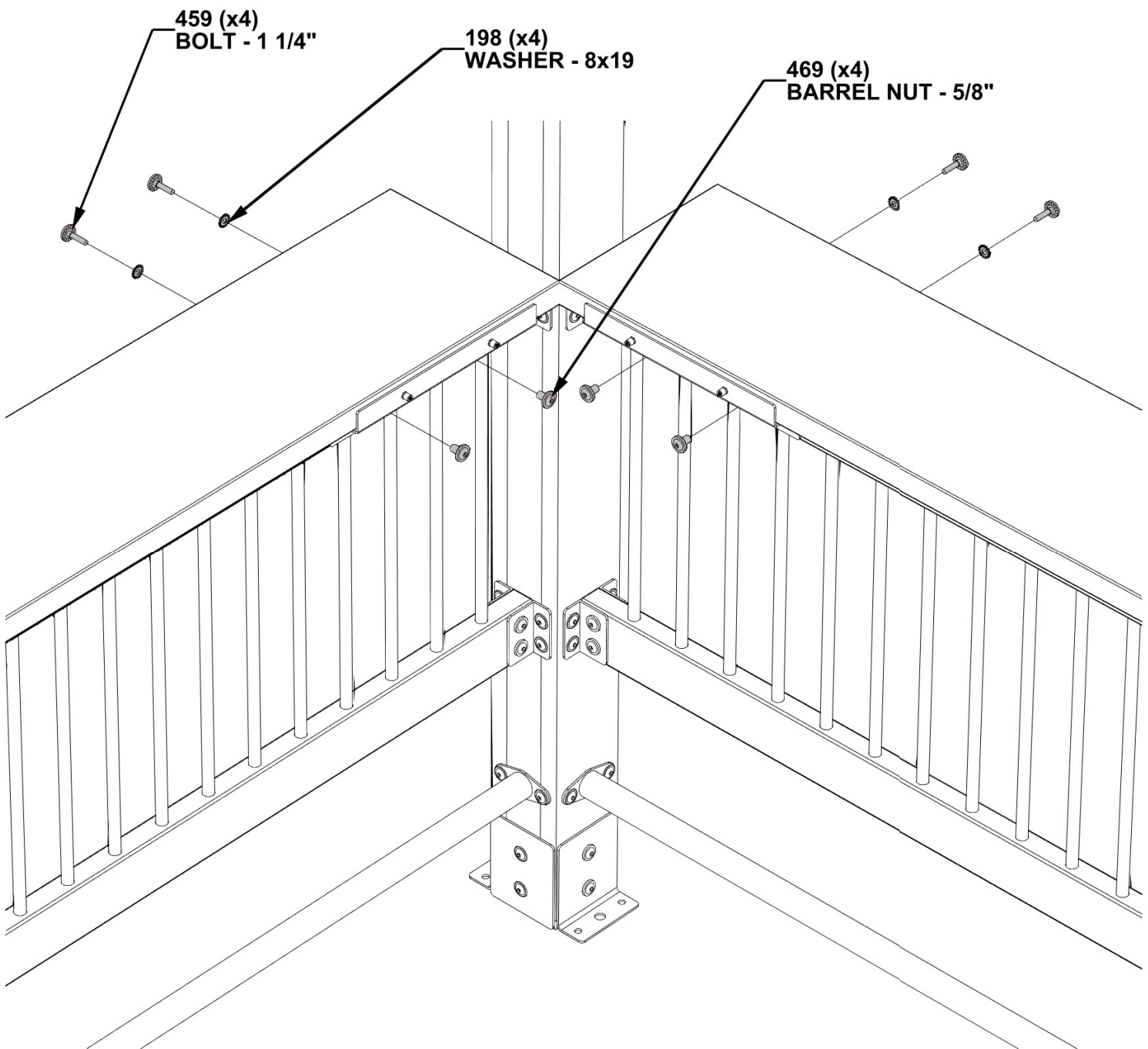

STEP 19 - GAZEBO ASSEMBLY

(ASSEMBLY INSTRUCTION STEPS DEPICTS ANGLE TABLE CONFIGURATION)

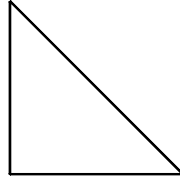

A4M01475 | CORNER TABLE
(x1) (ANGLE CONFIGURATION ONLY)

CORNER TABLE WILL SLIP INTO GAP BETWEEN LARGE TABLES AND EDGE OF BRACKET.

475 (x1)
CORNER TABLE

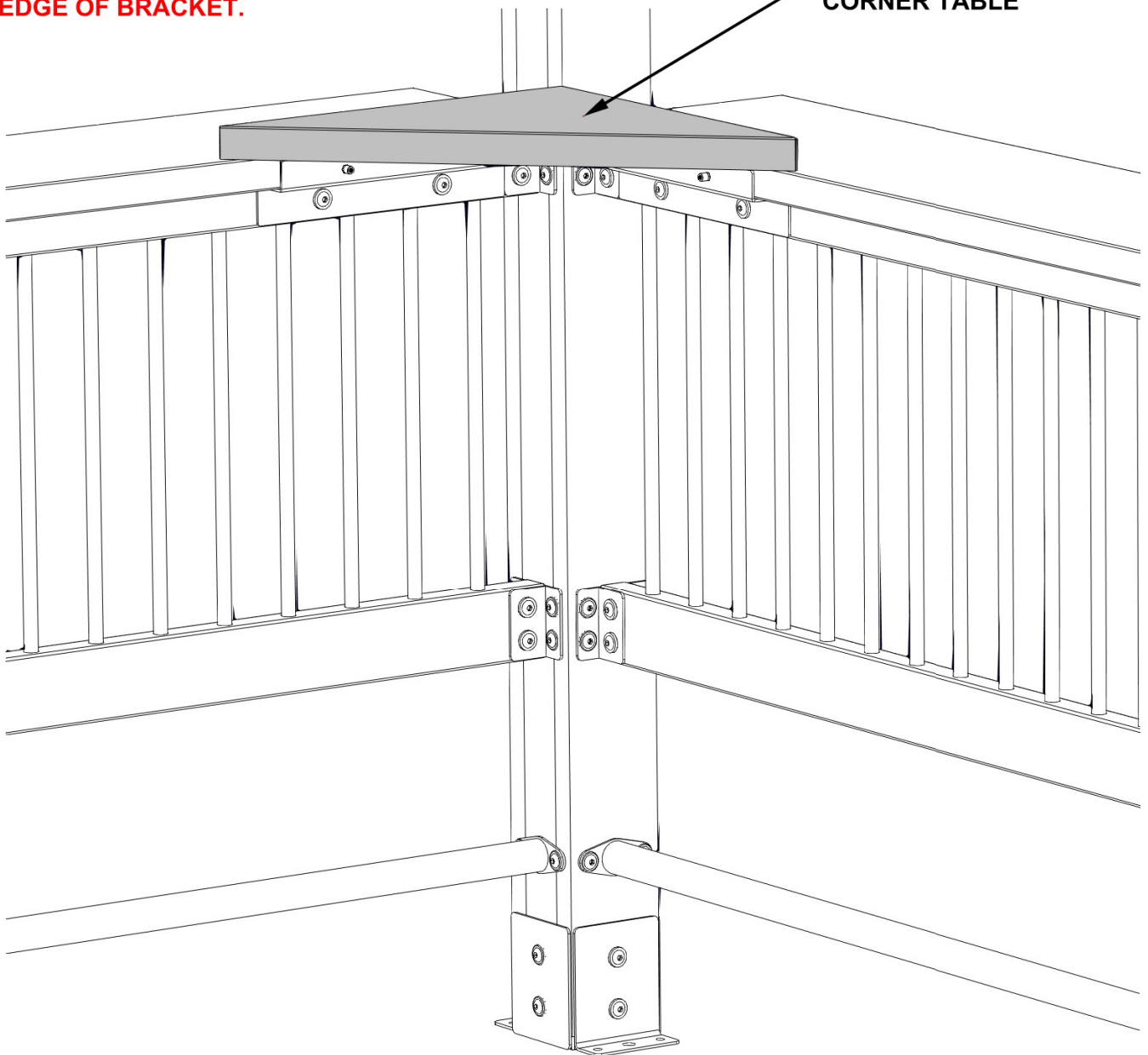

STEP 20 - GAZEBO ASSEMBLY

(ASSEMBLY INSTRUCTION STEPS DEPICTS ANGLE TABLE CONFIGURATION)

QTY	PART NUMBER	DESCRIPTION
4	H100171	BOLT WH 1/4x1 BLK

NOTES:
WITH TOP SURFACE OF CORNER TABLE LEVEL WITH TWO
LARGE TABLES, FASTEN BOLTS TO HOLD IN PLACE.
DO NOT OVERTIGHTEN BOLTS.

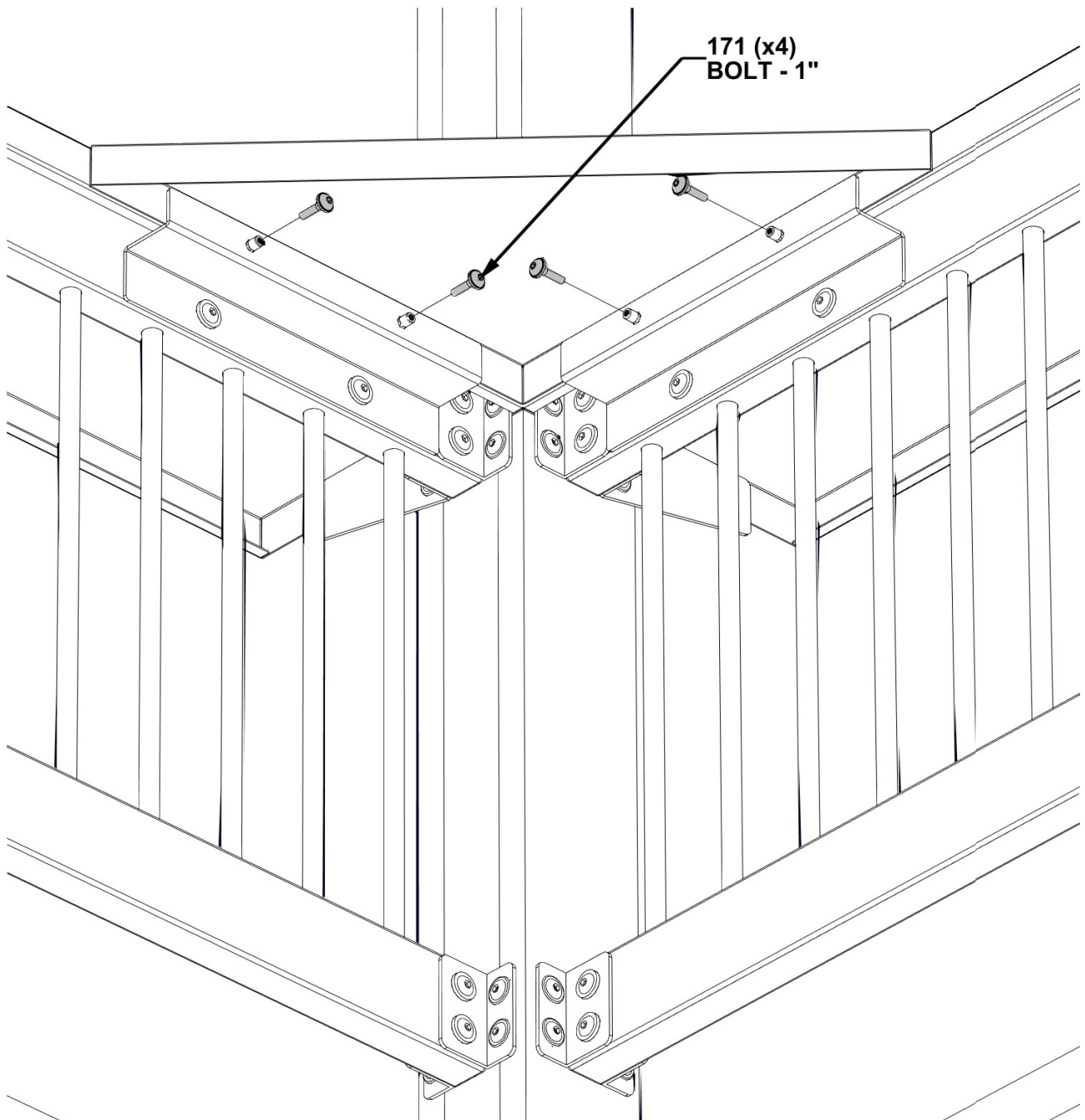

STEP 21 - GAZEBO ASSEMBLY

(ASSEMBLY INSTRUCTION STEPS DEPICTS ANGLE TABLE CONFIGURATION)

QTY	PART NUMBER	DESCRIPTION
16	H100630	WASHER FLAT 8x19 BLK
16	H100120	CONCRETE ANCHOR 1/4x2

NOTES:
MANUFACTURER RECOMMENDS INSTALLATION ON CONCRETE SURFACE OR CONCRETE POST PADS. SEE BELOW.

FOR INSTALLATION ON WOOD DECKS, YOU MUST ENSURE THERE IS AMPLE STRUCTURAL SUPPORT UNDER DECK.

NOTES:
PRE-DRILL HOLES FOR CONCRETE ANCHORS USING A 3/16" CONCRETE DRILL BIT.

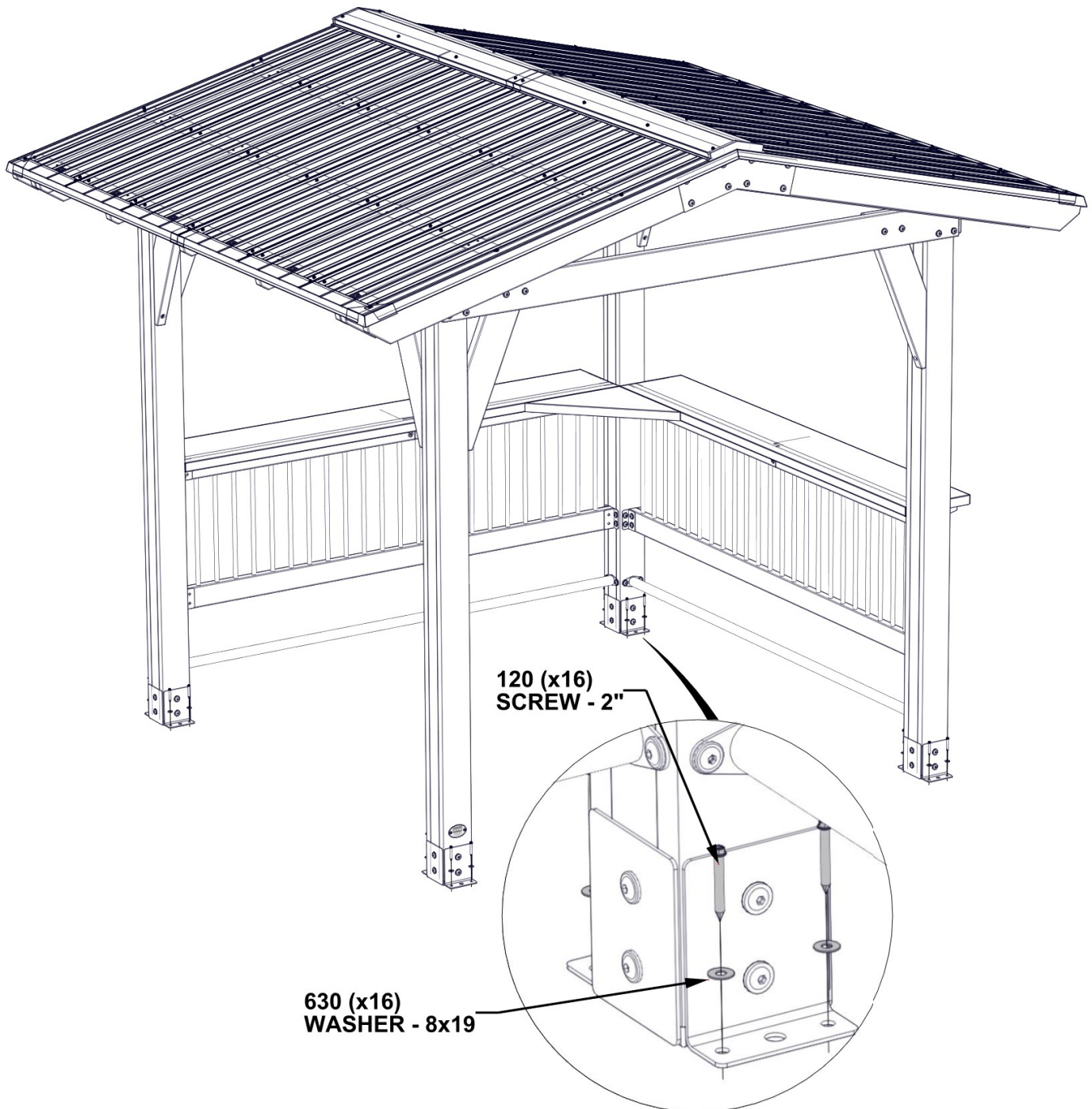

STEP 22: ELECTRICAL ENCLOSURE

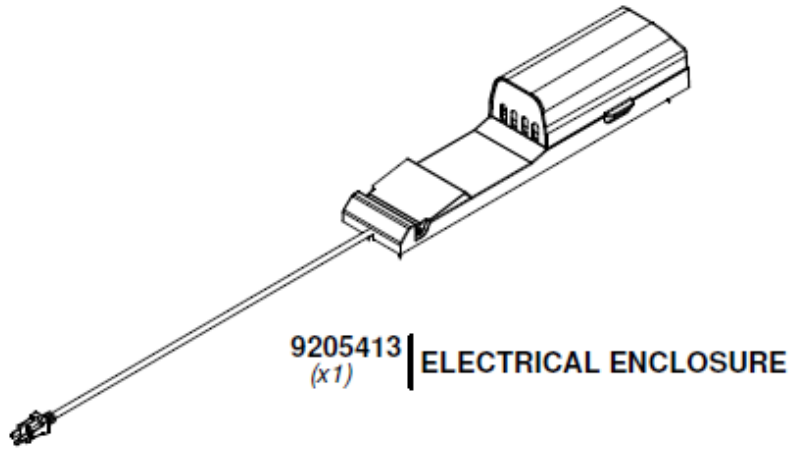

FOR ELECTRICAL ENCLOSURE INSTALLATION REFER TO ASSEMBLY INSTRUCTIONS THAT COMES PACKAGED WITH THE ELECTRICAL ENCLOSURE KIT. INSTALL ON ANY POST THAT IS DESIRED. FOLLOW DIRECTIONS FOR PROPER INSTALLATION.

SPLIT TABLE CONFIGURATION

COMPLETE STEPS 23-37

NOTE: TABLE RAILS CAN BE ORIENTED OFF ANY POST.



STEP 23 - GAZEBO ASSEMBLY

(ASSEMBLY INSTRUCTION STEPS DEPICTS SPLIT TABLE CONFIGURATION)

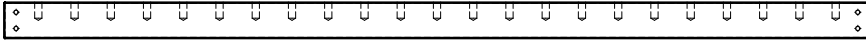

E1 | RAIL-W4L16362
(x2) | 1 7/16"x3 3/8"x80" (36x86x2032)



A4M00855 | L BRACKET
(x8) | 55x32x82x3.175

QTY	PART NUMBER	DESCRIPTION
8	H100469	NUT BARREL WH 5/16X5/8 BLK
8	H100459	BOLT WH 5/16x1 1/4 BLK

COMPLETE THIS STEP TWICE

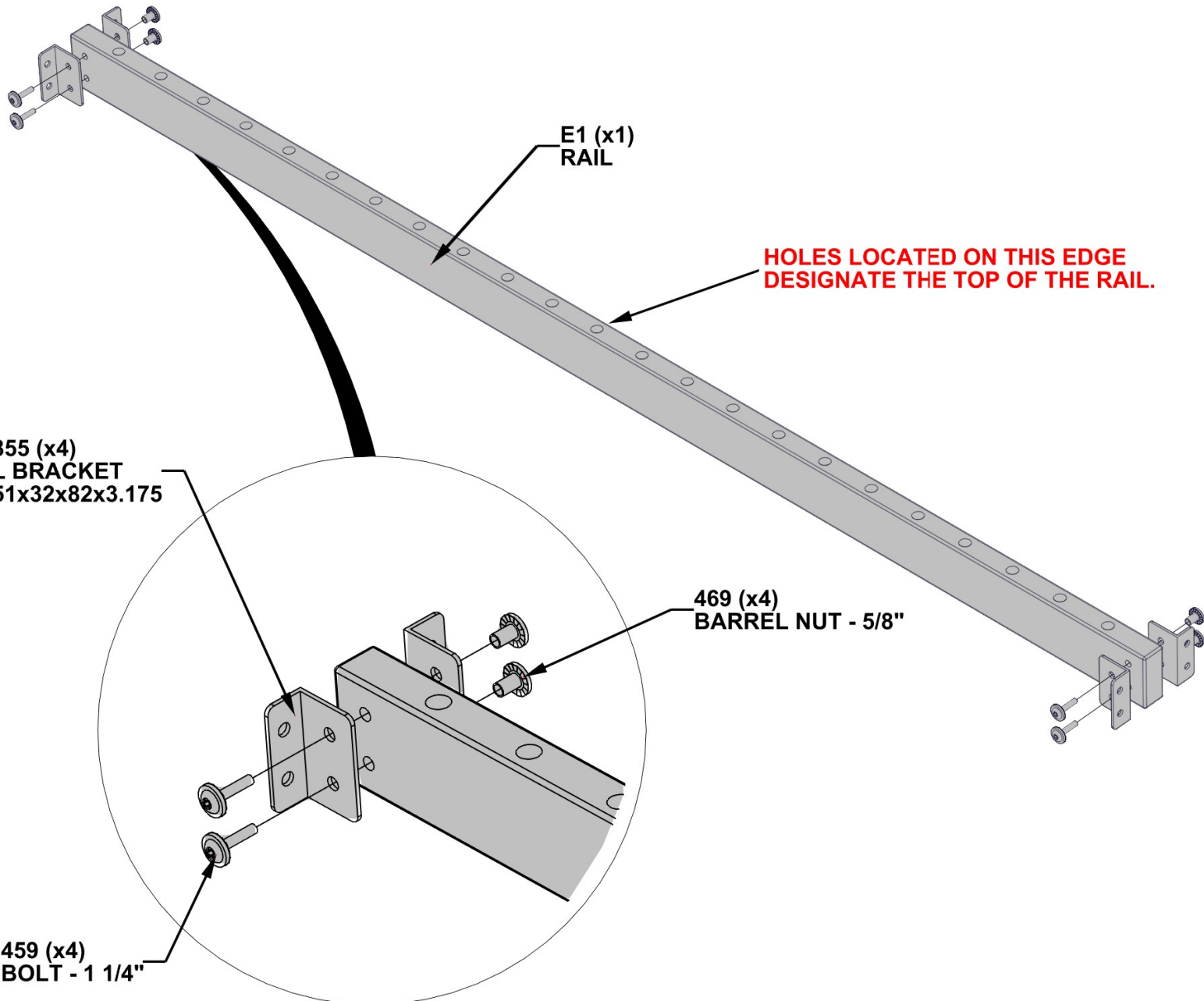

STEP 24 - GAZEBO ASSEMBLY

(ASSEMBLY INSTRUCTION STEPS DEPICTS SPLIT TABLE CONFIGURATION)

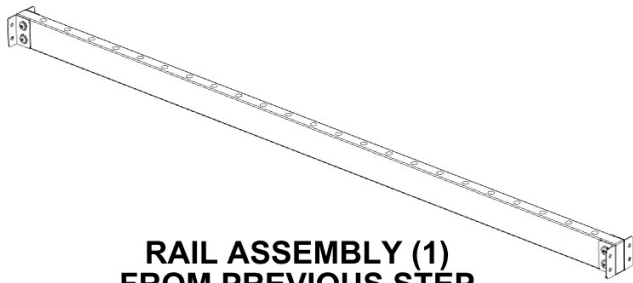

**RAIL ASSEMBLY (1)
FROM PREVIOUS STEP**

QTY	PART NUMBER	DESCRIPTION
8	H100854	LAG SCREW WH 5/16x1 BLK

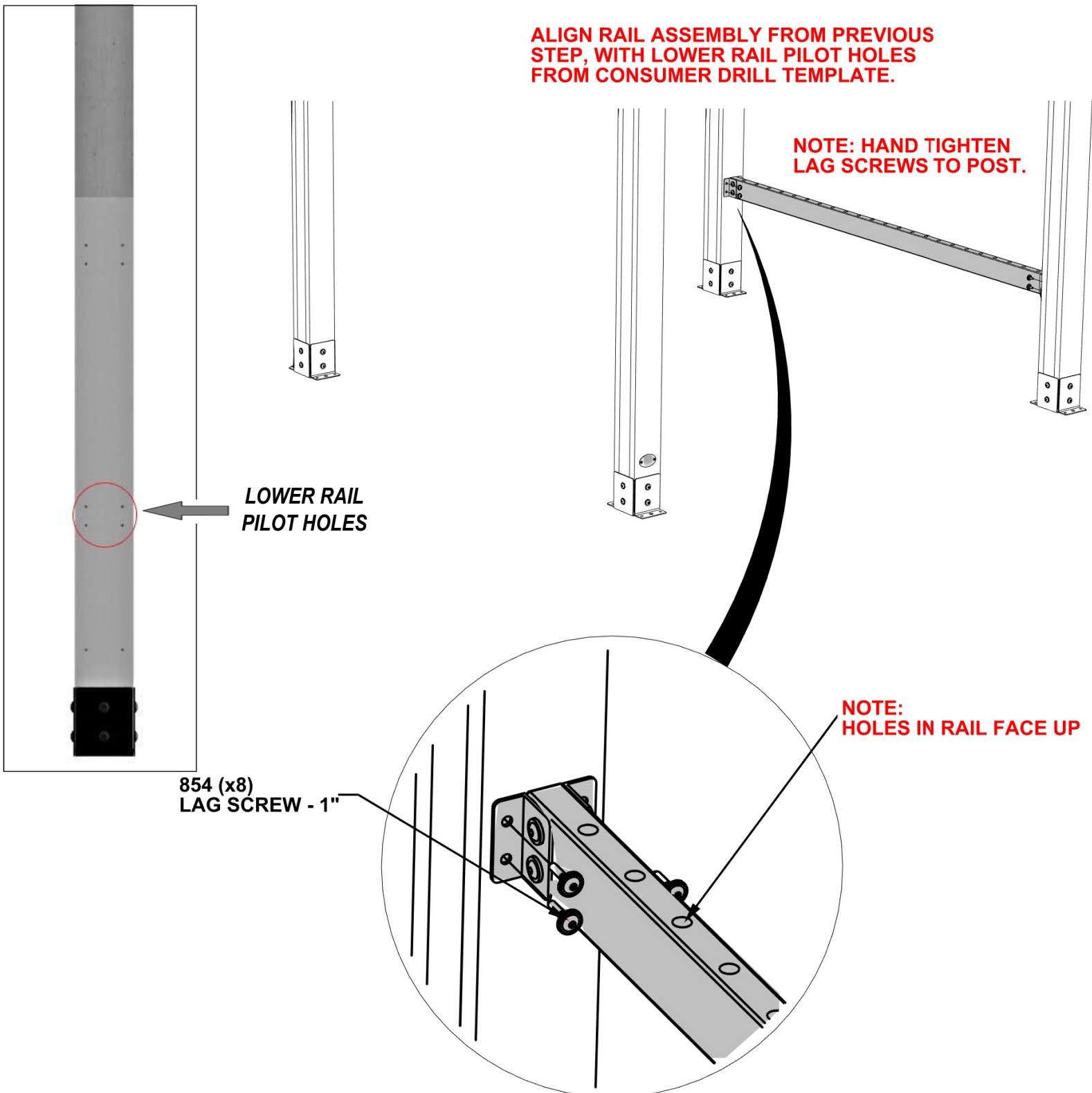

STEP 25 - GAZEBO ASSEMBLY

(ASSEMBLY INSTRUCTION STEPS DEPICTS
SPLIT TABLE CONFIGURATION)

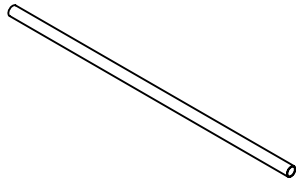

A4M01225
(x23) | METAL TUBE

PLACE METAL TUBES INTO BOTTOM BOARD OF RAIL ASSEMBLY

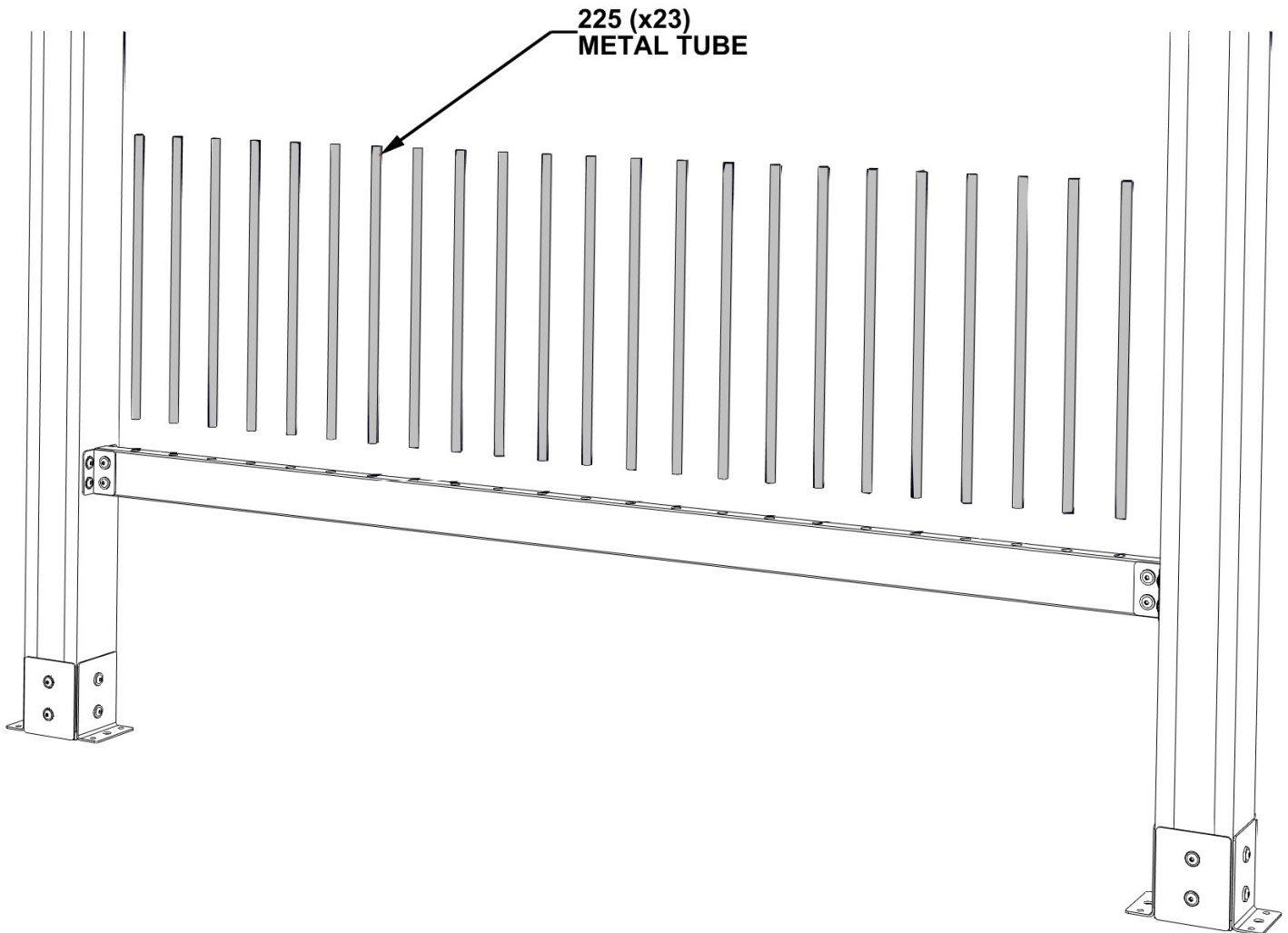

STEP 26 - GAZEBO ASSEMBLY

(ASSEMBLY INSTRUCTION STEPS DEPICTS SPLIT TABLE CONFIGURATION)

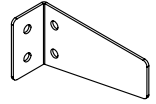

A4M00855 | L BRACKET
(x1) | 55x32x82x3.175

A4M01223 | L BRACKET
(x1)

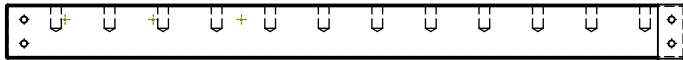

E2 | RAIL-W4L16363
(x1) | 1 7/16"x3 3/8"x42 7/16" (36x86x1078)

QTY	PART NUMBER	DESCRIPTION
2	H100469	NUT BARREL WH 5/16X5/8 BLK
2	H100459	BOLT WH 5/16x1 1/4 BLK
2	H100854	LAG SCREW WH 5/16x1 BLK

**PLACE METAL TUBES INTO BOTTOM OF RAIL BOARD.
ALIGN RAIL WITH UPPER RAIL PILOT HOLES
FROM CONSUMER DRILL TEMPLATE.**

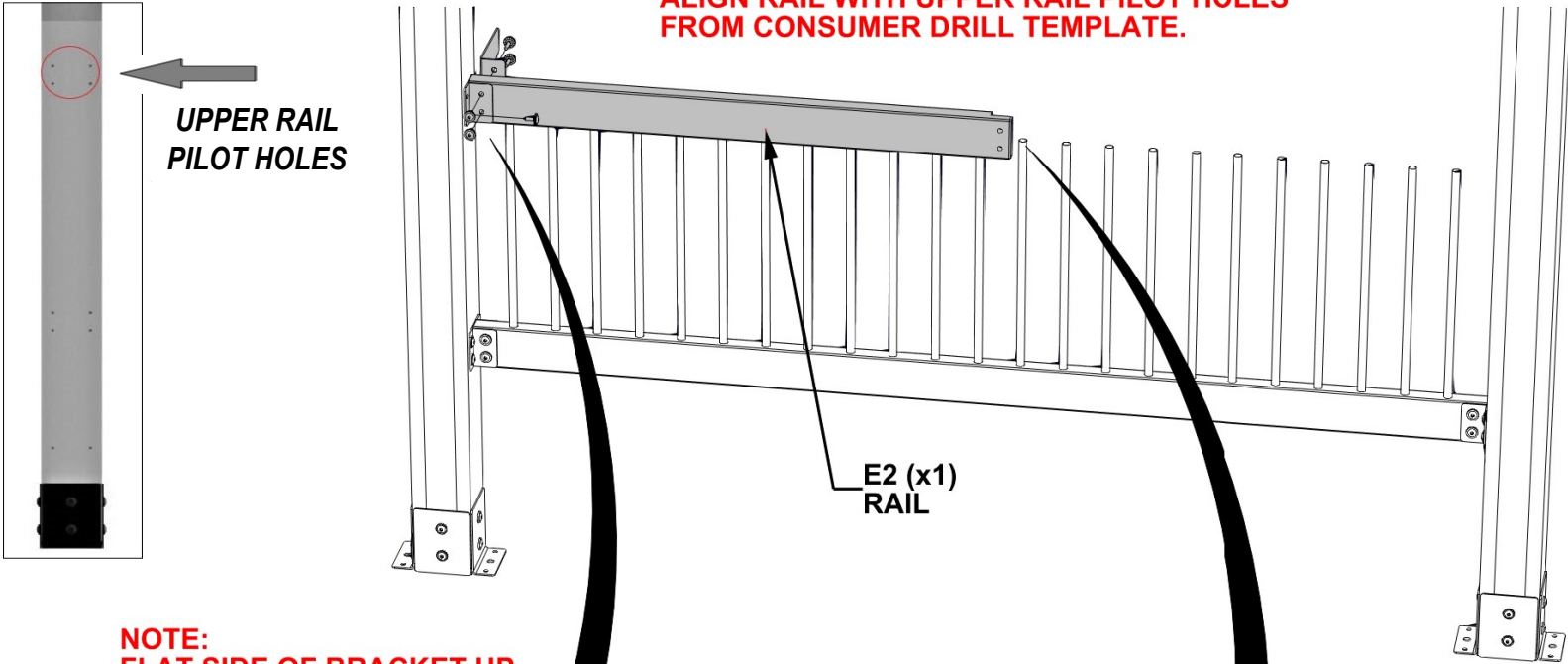

**NOTE:
FLAT SIDE OF BRACKET UP**

**NOTE:
LAP ORIENTATION**

**469 (x2)
BARREL NUT - 5/8"**

**223 (x1)
L BRACKET**

**459 (x2)
BOLT - 1 1/4"**

**855 (x1)
L BRACKET
51x32x82x3.175**

**854 (x2)
LAG SCREW - 1"**

**HAND TIGHTEN BOTTOM TWO
LAG SCREWS ONLY. LEAVE LOOSE
UNTIL TABLE TOP IS INSTALLED.**

STEP 27 - GAZEBO ASSEMBLY

(ASSEMBLY INSTRUCTION STEPS DEPICTS SPLIT TABLE CONFIGURATION)

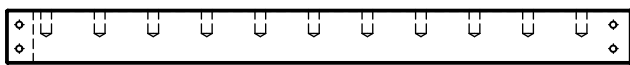

E3 | RAIL-W4L16364
(x1) | 1 7/16"x3 3/8"x39 1/8" (36x86x993)



A4M00855 | L BRACKET
(x1) | 55x32x82x3.175

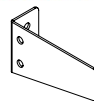

A4M01224
(x1) | L BRACKET

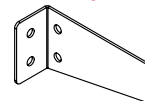

A4M01223
(x1) | L BRACKET

QTY	PART NUMBER	DESCRIPTION
2	H100379	T-NUT 5/16 BLK
2	H100469	NUT BARREL WH 5/16X5/8 BLK
2	H100407	BOLT WH 5/16x1 1/2 BLK
2	H100854	LAG SCREW WH 5/16x1 BLK
2	H100459	BOLT WH 5/16x1 1/4 BLK

**PLACE METAL TUBES INTO BOTTOM OF RAIL BOARD.
ALIGN RAIL WITH UPPER RAIL PILOT HOLES
FROM CONSUMER DRILL TEMPLATE.**

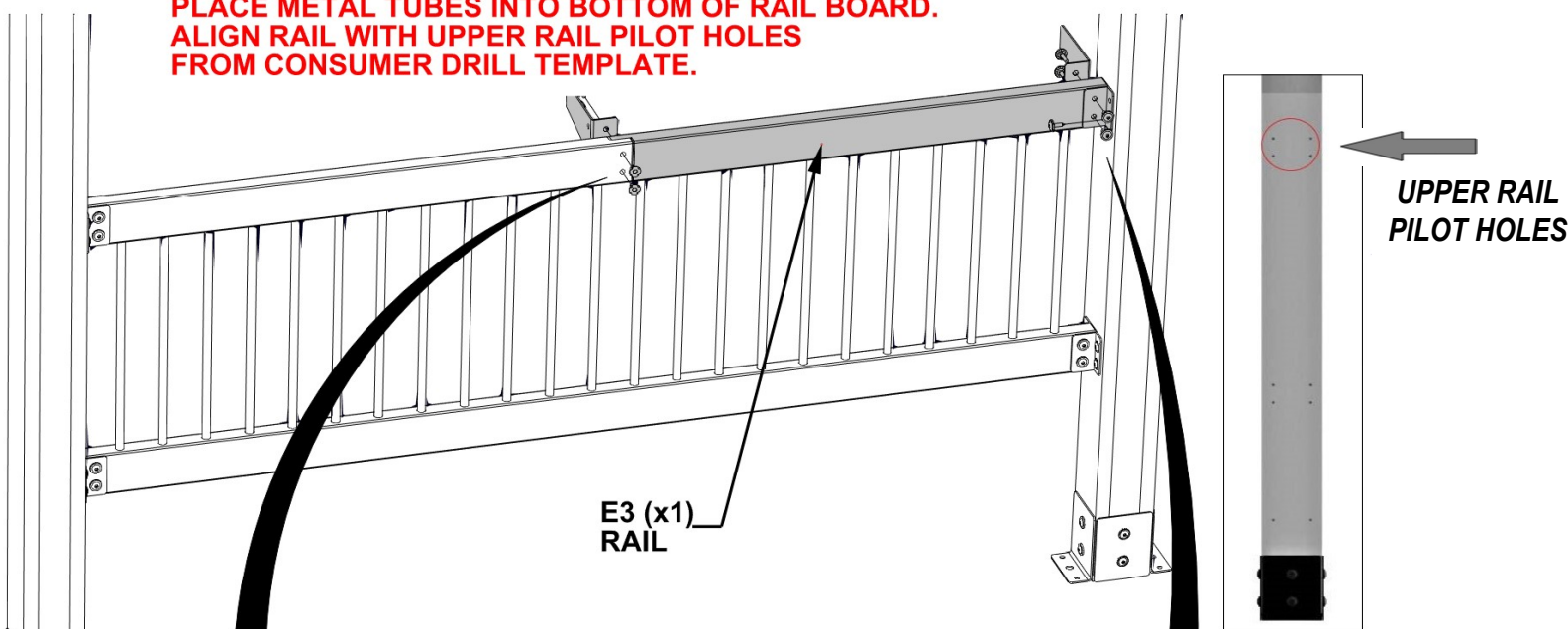

**E3 (x1)
RAIL**

**NOTE:
FLAT SIDE OF BRACKET UP**

**223 (x1)
L BRACKET**

**NOTE:
LAP ORIENTATION**

**224 (x1)
L BRACKET**

**407 (x2)
BOLT - 1 1/2"**

**459 (x2)
BOLT - 1 1/4"**

**855 (x1)
L BRACKET
51x32x82x3.175**

**379 (x2)
T-NUT - 5/16"**

**854 (x2)
LAG SCREW - 1"**

**469 (x2)
BARREL NUT - 5/8"**

**HAND TIGHTEN BOTTOM TWO
LAG SCREWS ONLY. LEAVE LOOSE
UNTIL TABLE TOP IS INSTALLED.**

STEP 28 - GAZEBO ASSEMBLY

(ASSEMBLY INSTRUCTION STEPS DEPICTS SPLIT TABLE CONFIGURATION)

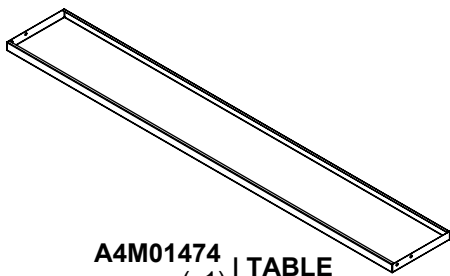

QTY	PART NUMBER	DESCRIPTION
4	H100854	LAG SCREW WH 5/16x1 BLK

A4M01474 (x1) | TABLE

INSTALL TABLE BETWEEN POST. SLIDE TABLE DOWN UNTIL IT REST ON TOP OF RAIL. INSERT LAG SCREWS ON EACH SIDE OF RAIL AS SHOWN BELOW.

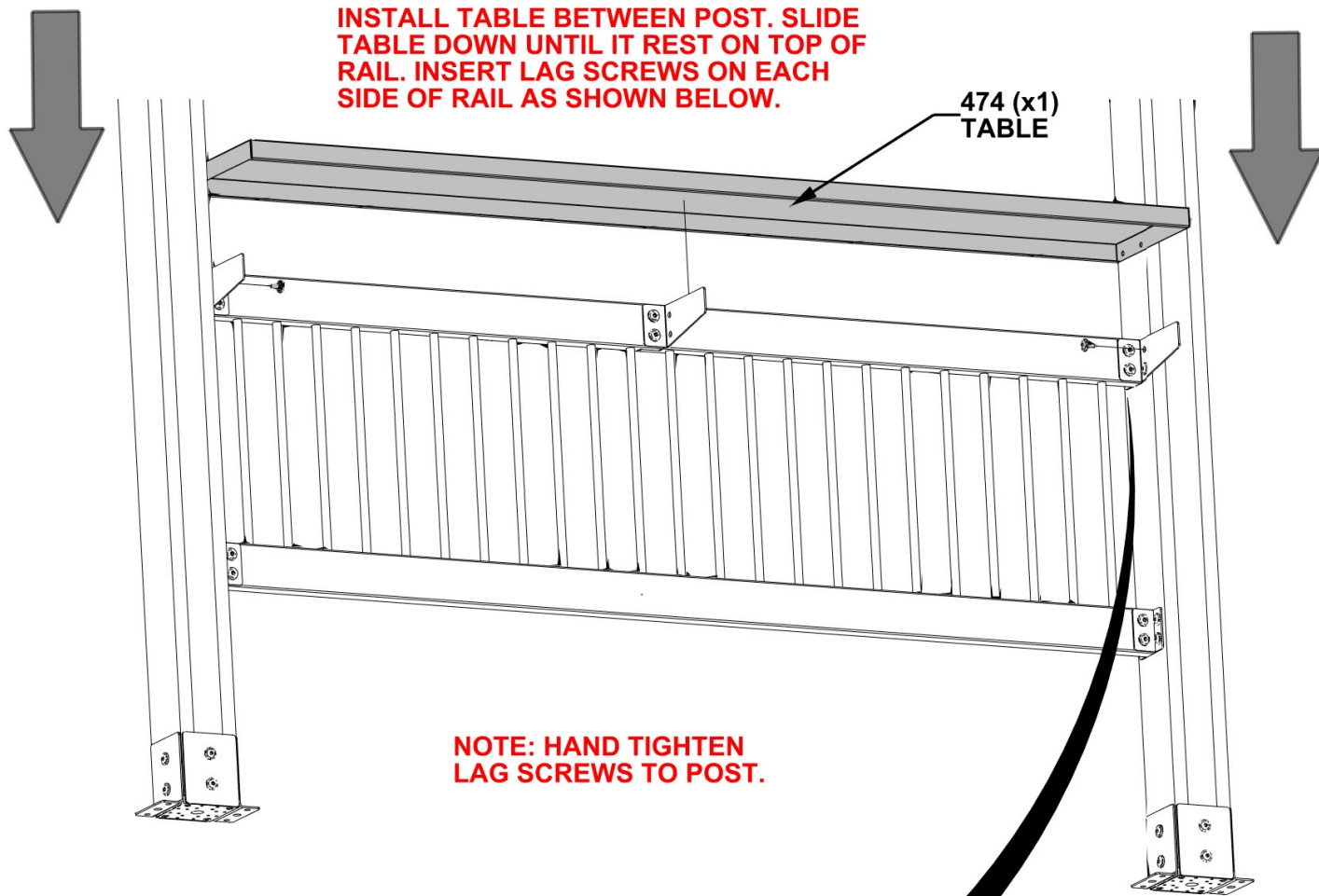

NOTE: HAND TIGHTEN LAG SCREWS TO POST.

HOLES IN TABLE SHOULD ALIGN WITH HOLES IN BRACKETS

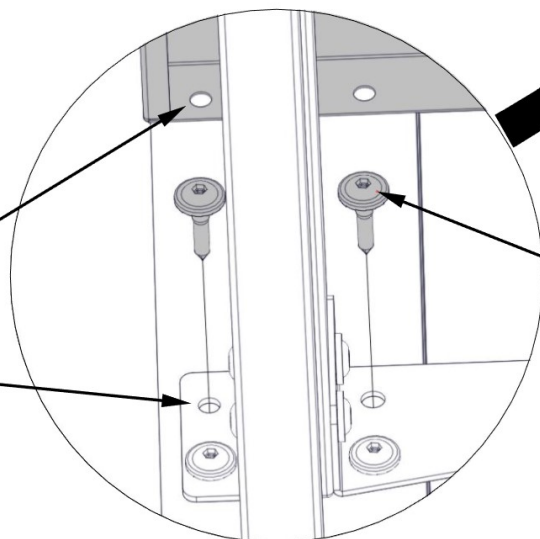

854 (x4) LAG SCREW - 1"

STEP 29 - GAZEBO ASSEMBLY

(ASSEMBLY INSTRUCTION STEPS DEPICTS SPLIT TABLE CONFIGURATION)

QTY	PART NUMBER	DESCRIPTION
4	H100854	LAG SCREW WH 5/16x1 BLK

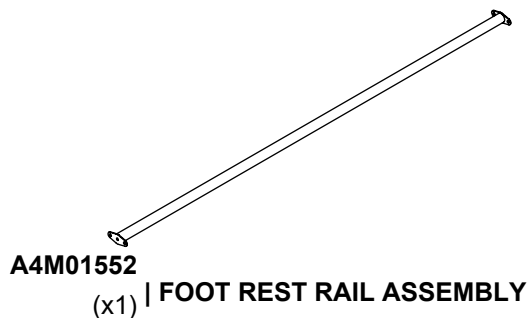

ALIGN FOOT REST RAIL ASSEMBLY WITH BOTTOM TWO PILOT HOLES FROM CONSUMER DRILL TEMPLATE.

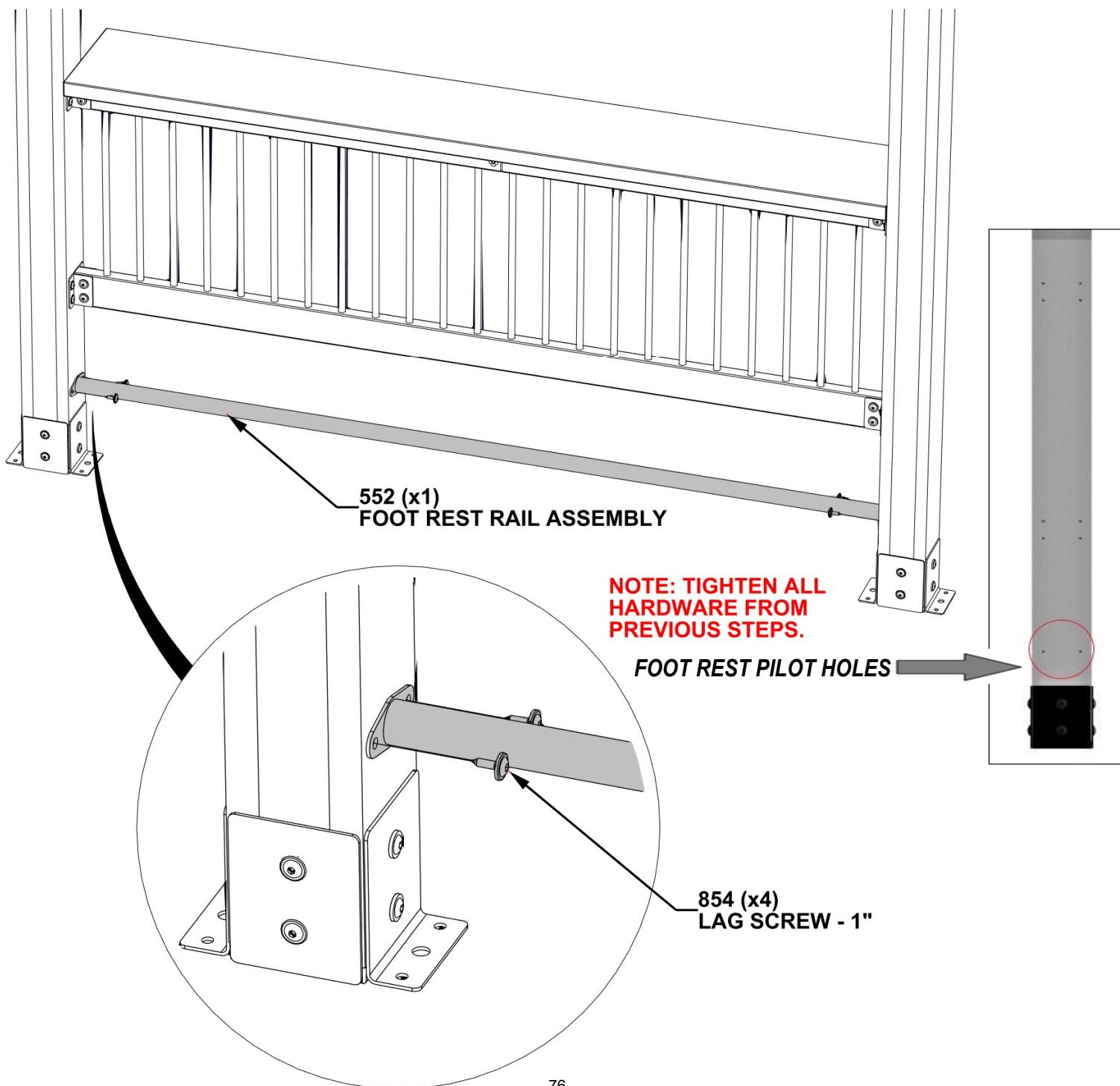

STEP 30 - GAZEBO ASSEMBLY

(ASSEMBLY INSTRUCTION STEPS DEPICTS SPLIT TABLE CONFIGURATION)

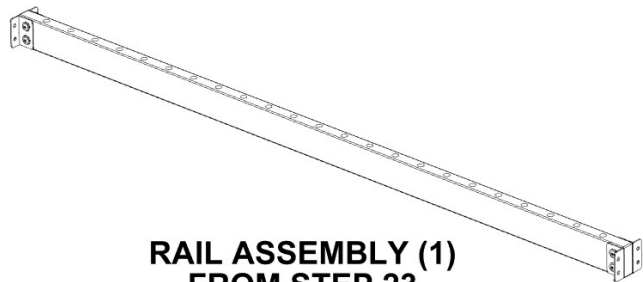

**RAIL ASSEMBLY (1)
FROM STEP 23**

QTY	PART NUMBER	DESCRIPTION
8	H100854	LAG SCREW WH 5/16x1 BLK

ALIGN RAIL ASSEMBLY FROM STEP 23, WITH LOWER RAIL PILOT HOLES FROM CONSUMER DRILL TEMPLATE.

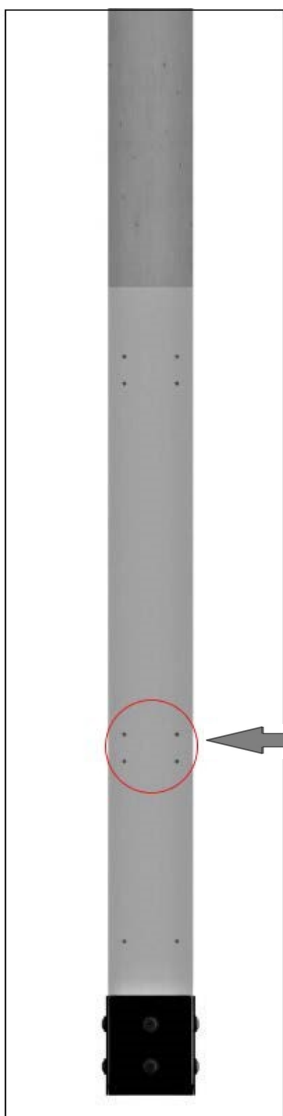

**LOWER RAIL
PILOT HOLES**

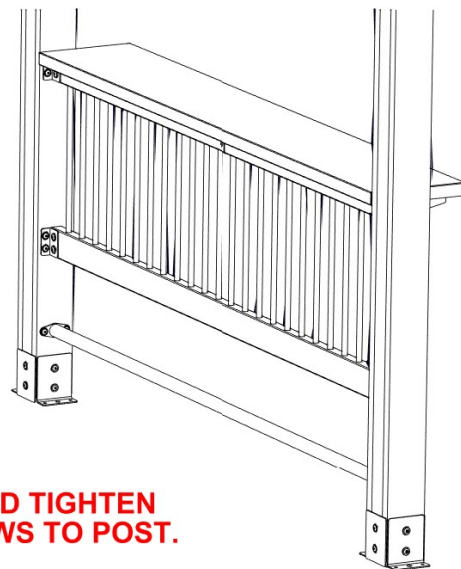
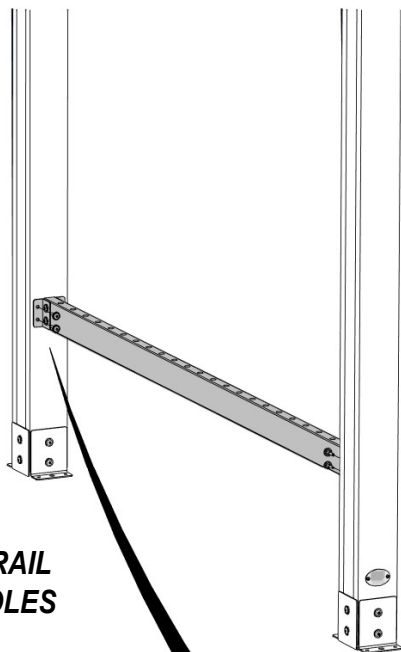

**NOTE: HAND TIGHTEN
LAG SCREWS TO POST.**

**NOTE:
HOLES IN RAIL FACE UP**

**854 (x8)
LAG SCREW - 1"**

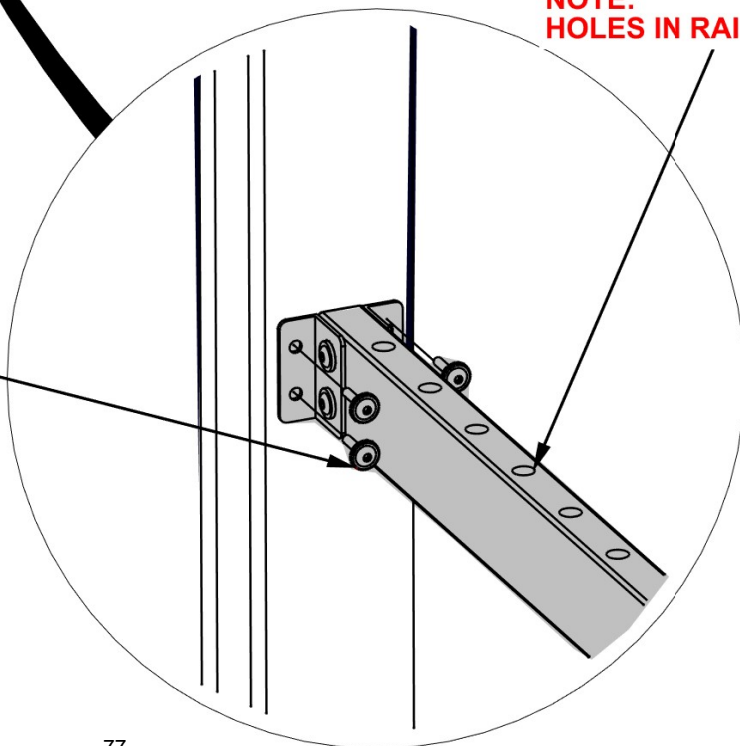

STEP 31 - GAZEBO ASSEMBLY

(ASSEMBLY INSTRUCTION STEPS DEPICTS
SPLIT TABLE CONFIGURATION)

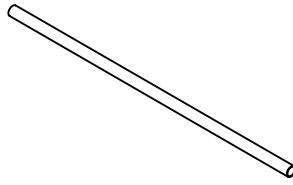

A4M01225
(x23) | METAL TUBE

PLACE METAL TUBES INTO BOTTOM BOARD OF RAIL ASSEMBLY

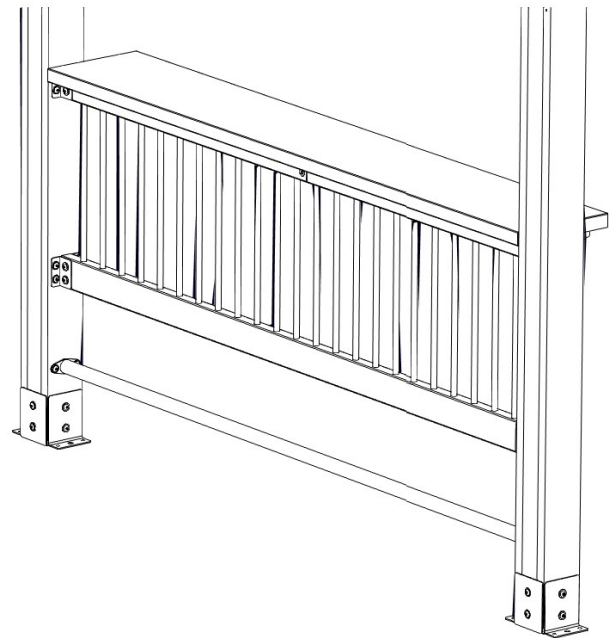
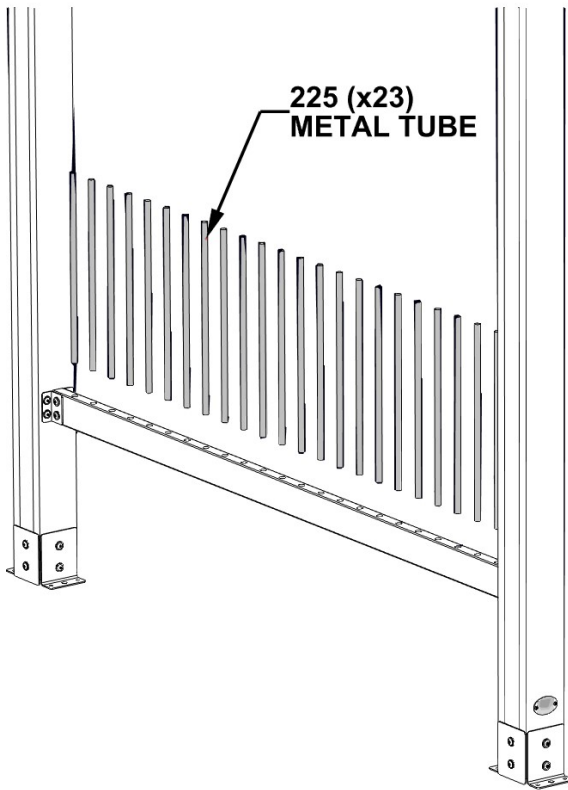

STEP 32 - GAZEBO ASSEMBLY

(ASSEMBLY INSTRUCTION STEPS DEPICTS SPLIT TABLE CONFIGURATION)



E3 | RAIL-W4L16364
(x1) | 1 7/16"x3 3/8"x39 1/8" (36x86x993)



A4M01224 | L BRACKET
(x1)



A4M00855 | L BRACKET
(x1) | 55x32x82x3.175

QTY	PART NUMBER	DESCRIPTION
2	H100469	NUT BARREL WH 5/16X5/8 BLK
2	H100459	BOLT WH 5/16x1 1/4 BLK
2	H100854	LAG SCREW WH 5/16x1 BLK

**PLACE METAL TUBES INTO BOTTOM OF RAIL BOARD.
ALIGN RAIL WITH UPPER RAIL PILOT HOLES FROM
CONSUMER DRILL TEMPLATE.**

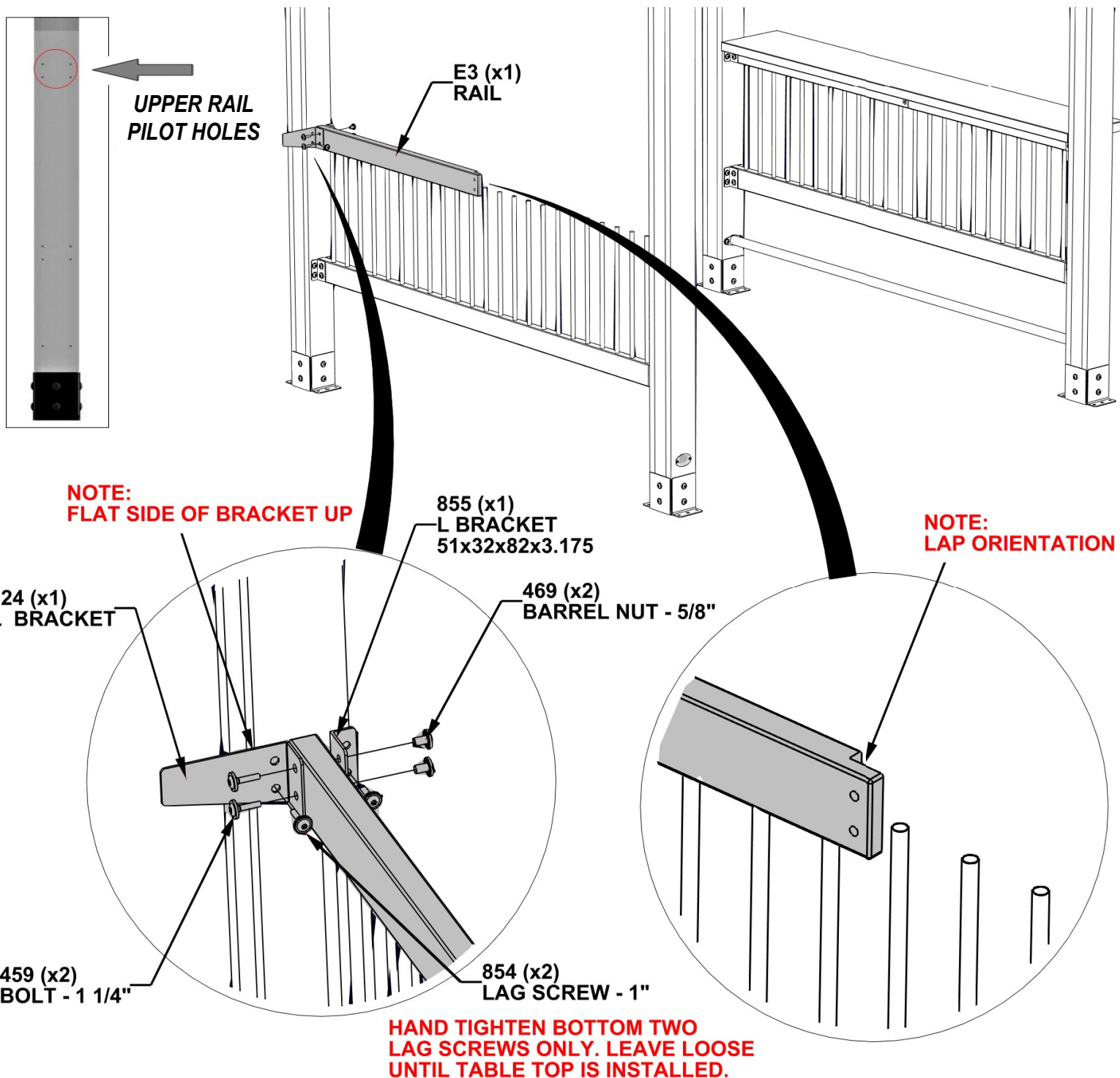

**HAND TIGHTEN BOTTOM TWO
LAG SCREWS ONLY. LEAVE LOOSE
UNTIL TABLE TOP IS INSTALLED.**

STEP 33 - GAZEBO ASSEMBLY

(ASSEMBLY INSTRUCTION STEPS DEPICTS SPLIT TABLE CONFIGURATION)

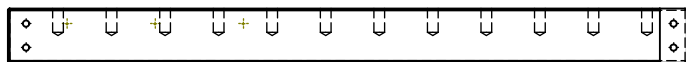

E2 | RAIL-W4L16363
(x1) | 1 7/16"x3 3/8"x42 7/16" (36x86x1078)



A4M00855 | L BRACKET
(x1) | 55x32x82x3.175

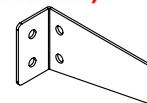

A4M01223 | L BRACKET
(x2)

QTY	PART NUMBER	DESCRIPTION
2	H100459	BOLT WH 5/16x1 1/4 BLK
2	H100379	T-NUT 5/16 BLK
2	H100469	NUT BARREL WH 5/16X5/8 BLK
2	H100407	BOLT WH 5/16x1 1/2 BLK
2	H100854	LAG SCREW WH 5/16x1 BLK

**PLACE METAL TUBES INTO BOTTOM OF RAIL BOARD.
ALIGN RAIL WITH UPPER RAIL PILOT HOLES FROM
CONSUMER DRILL TEMPLATE.**

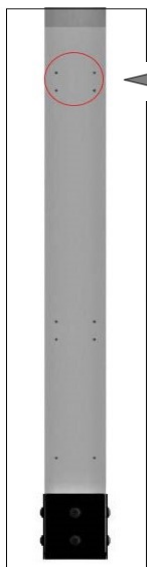

**UPPER RAIL
PILOT HOLES**

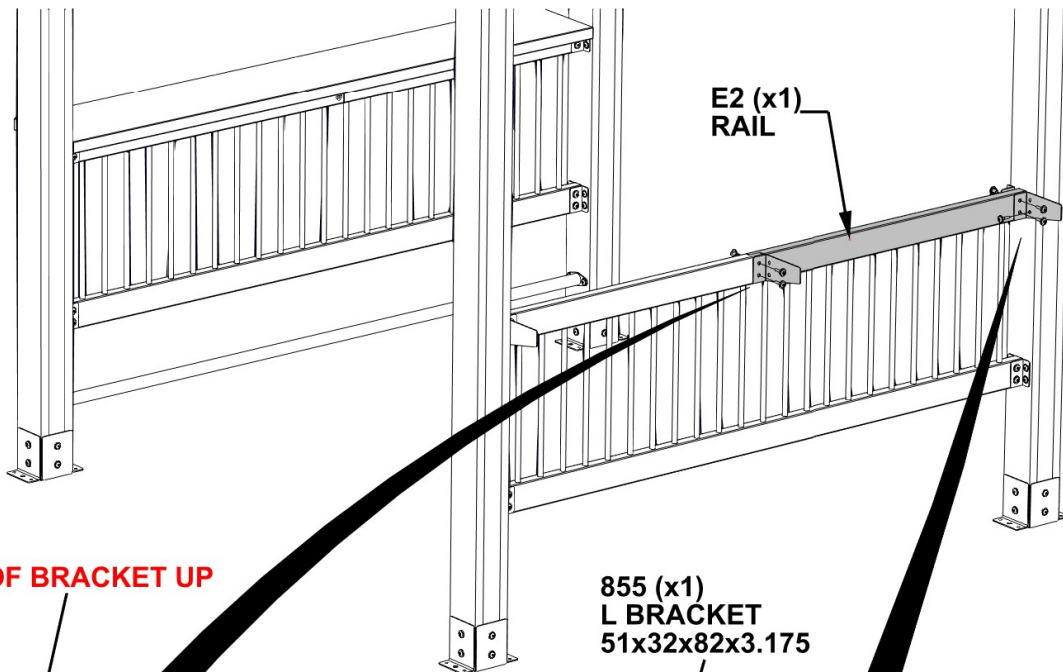

**NOTE:
FLAT SIDE OF BRACKET UP**

**NOTE:
LAP ORIENTATION**

**379 (x2)
T-NUT - 5/16"**

**469 (x2)
BARREL NUT - 5/8"**

**223 (x1)
L BRACKET**

**223 (x1)
L BRACKET**

**854 (x2)
LAG SCREW - 1"**

**HAND TIGHTEN BOTTOM TWO
LAG SCREWS ONLY. LEAVE LOOSE
UNTIL TABLE TOP IS INSTALLED.**

**407 (x2)
BOLT - 1 1/2"**

**459 (x2)
BOLT - 1 1/4"**

STEP 34 - GAZEBO ASSEMBLY

(ASSEMBLY INSTRUCTION STEPS DEPICTS SPLIT TABLE CONFIGURATION)

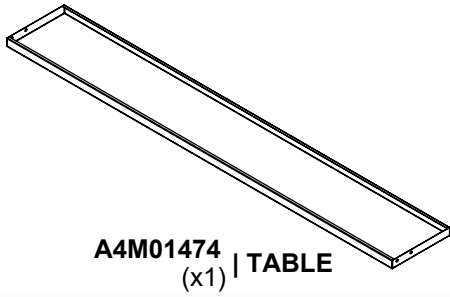

QTY	PART NUMBER	DESCRIPTION
4	H100854	LAG SCREW WH 5/16x1 BLK

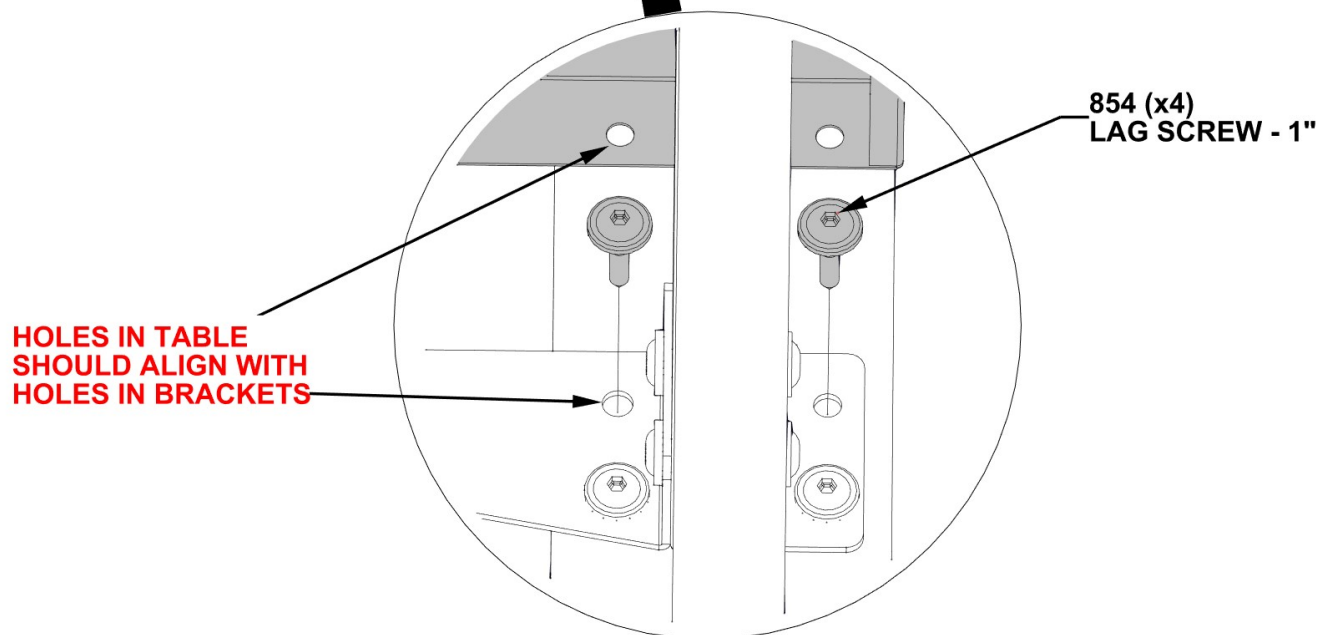
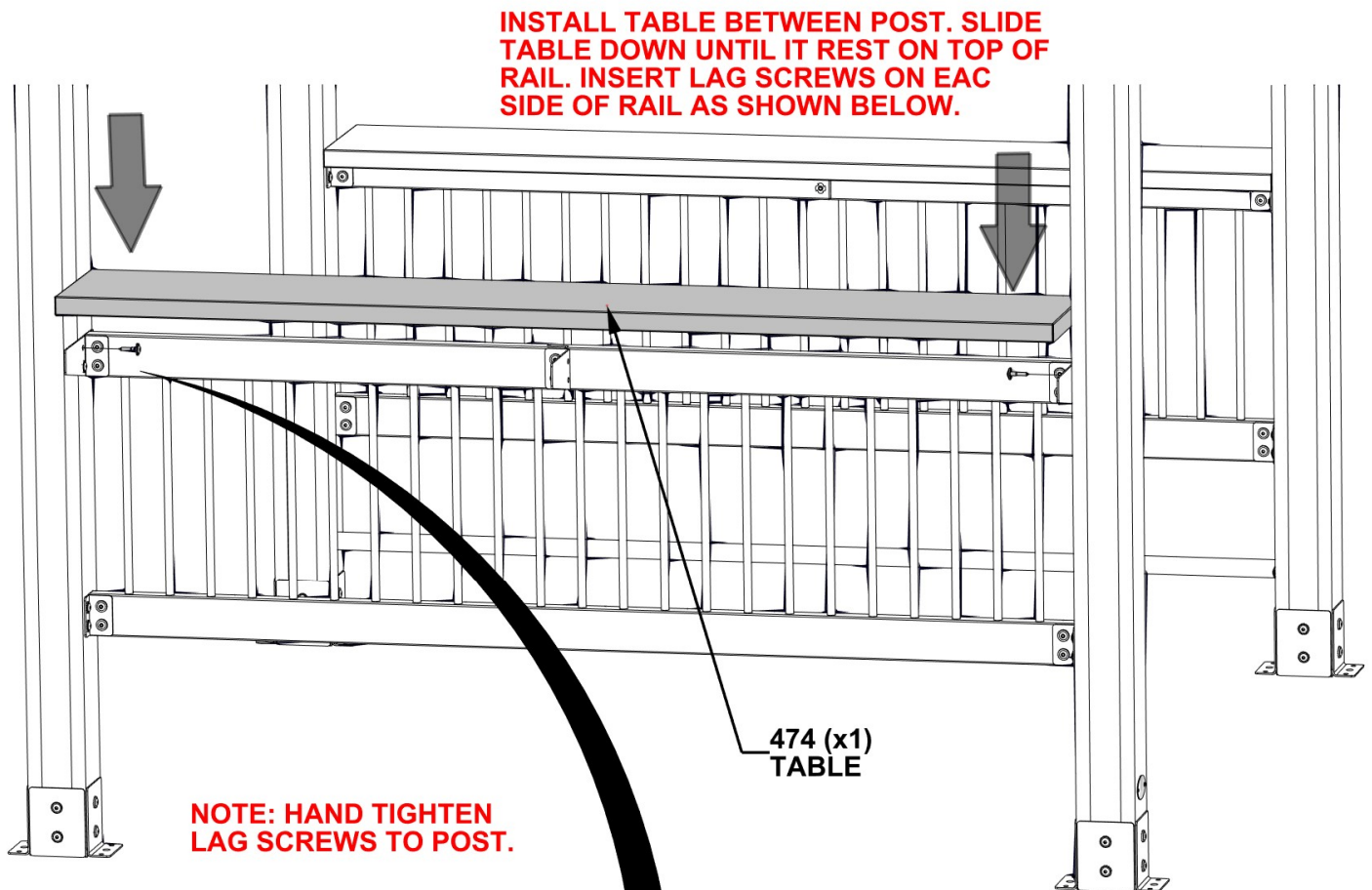

STEP 35 - GAZEBO ASSEMBLY

(ASSEMBLY INSTRUCTION STEPS DEPICTS SPLIT TABLE CONFIGURATION)

QTY	PART NUMBER	DESCRIPTION
4	H100854	LAG SCREW WH 5/16x1 BLK

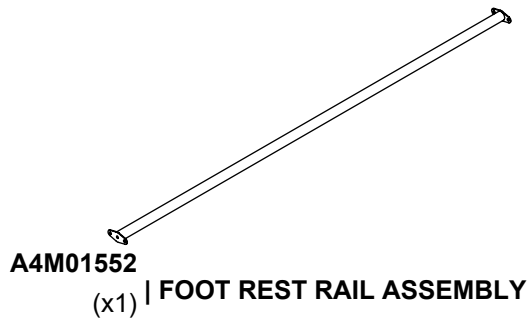

ALIGN FOOT REST RAIL ASSEMBLY WITH BOTTOM TWO PILOT HOLES FROM CONSUMER DRILL TEMPLATE.

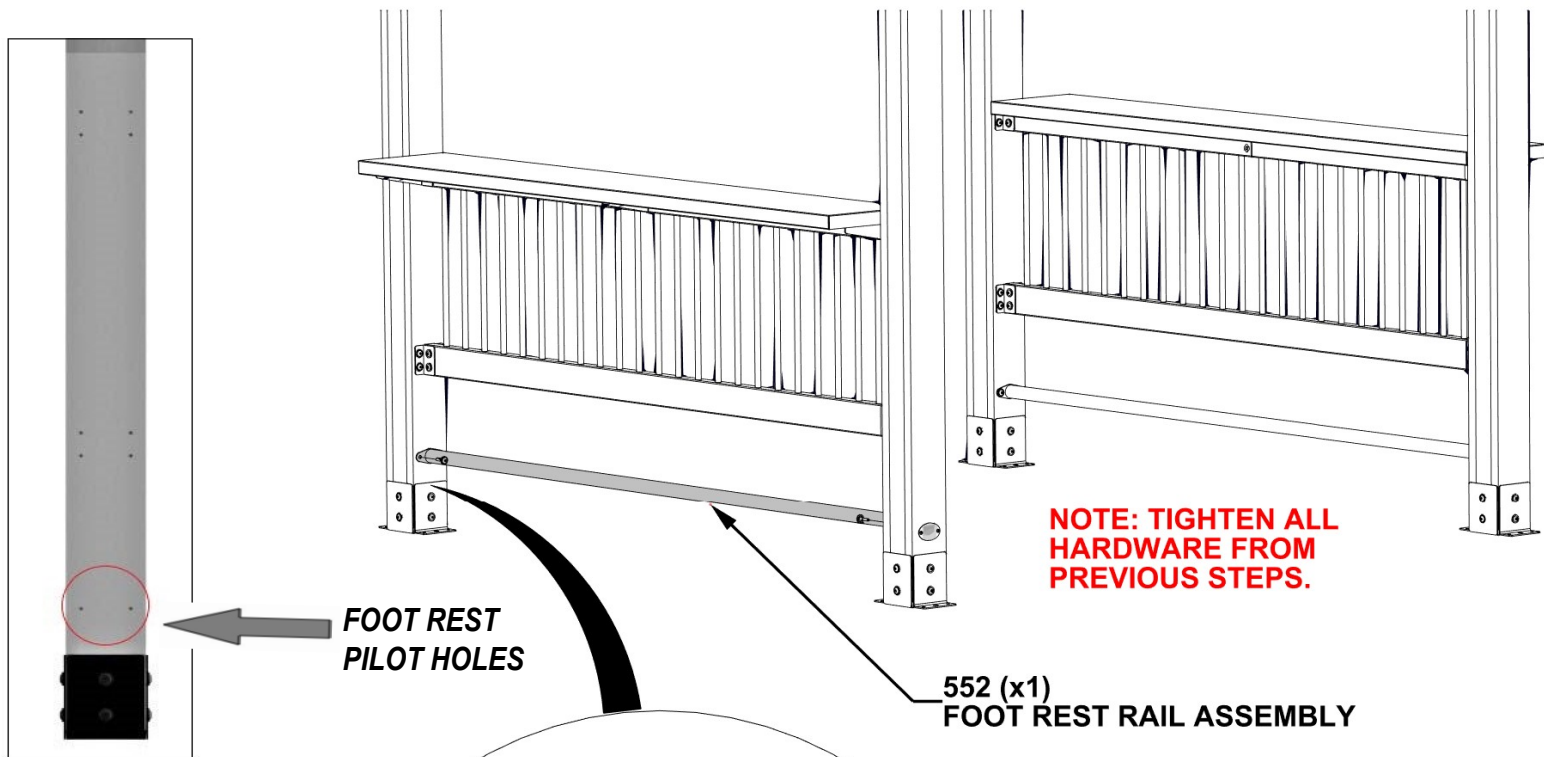

854 (x4)
LAG SCREW - 1"

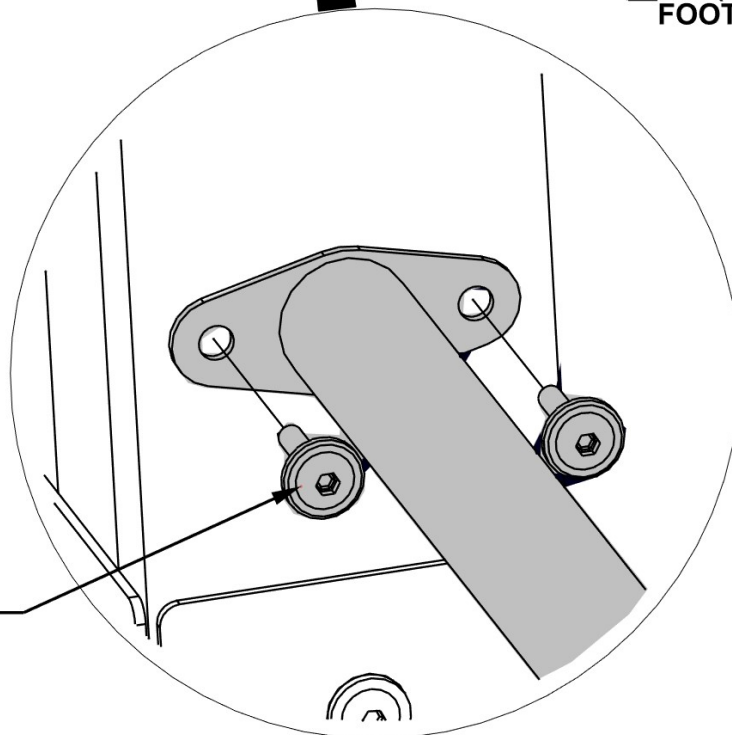

STEP 36 - GAZEBO ASSEMBLY

(ASSEMBLY INSTRUCTION STEPS DEPICTS SPLIT TABLE CONFIGURATION)

QTY	PART NUMBER	DESCRIPTION
16	H100630	WASHER FLAT 8x19 BLK
16	H100120	CONCRETE ANCHOR 1/4x2"

NOTES:
MANUFACTURER RECOMMENDS INSTALLATION ON CONCRETE SURFACE OR CONCRETE POST PADS. SEE BELOW.

FOR INSTALLATION ON WOOD DECKS, YOU MUST ENSURE THERE IS AMPLE STRUCTURAL SUPPORT UNDER DECK.

NOTES:
PRE-DRILL HOLES FOR CONCRETE ANCHORS USING A 3/16" CONCRETE DRILL BIT.

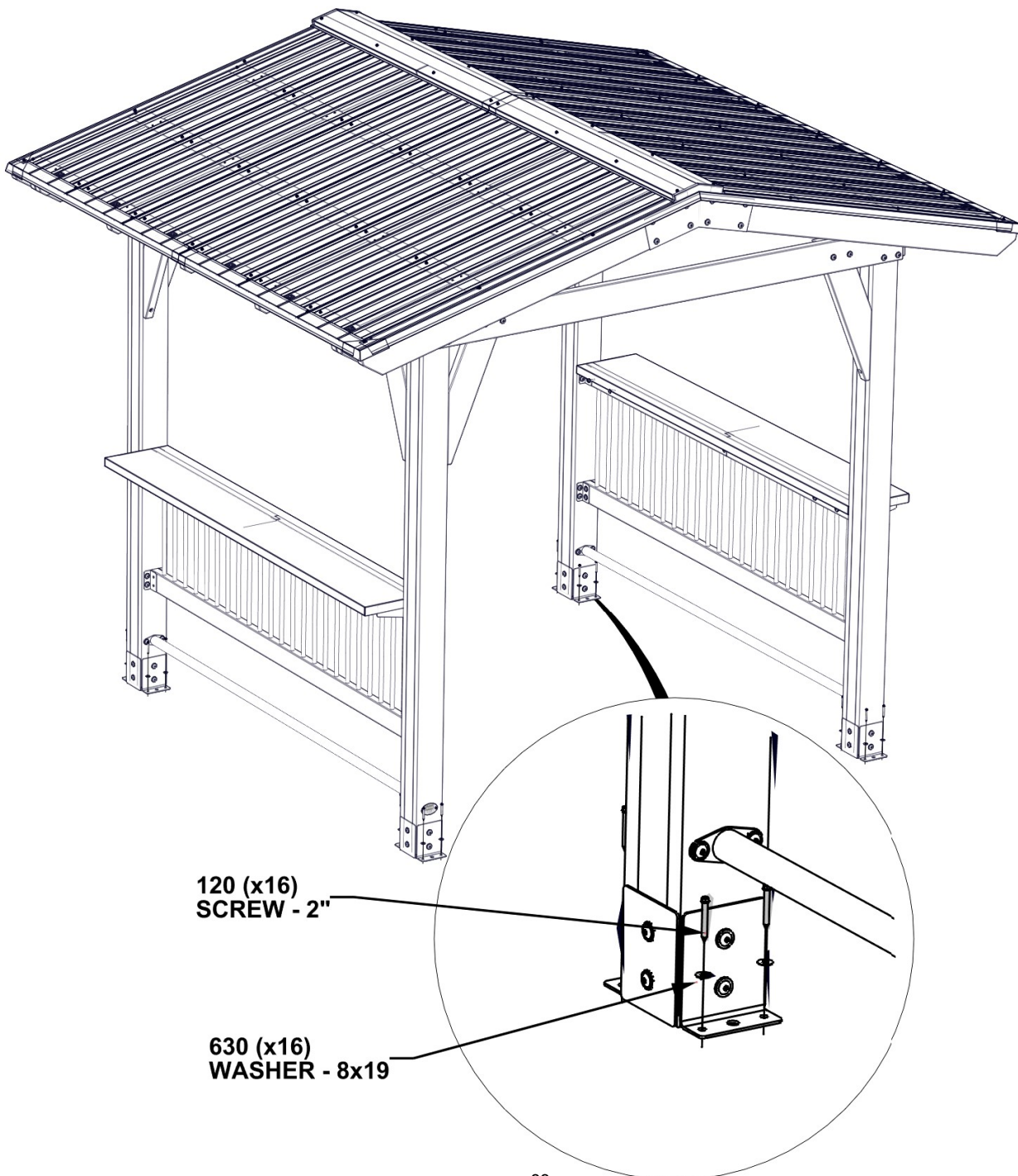

STEP 37: ELECTRICAL ENCLOSURE

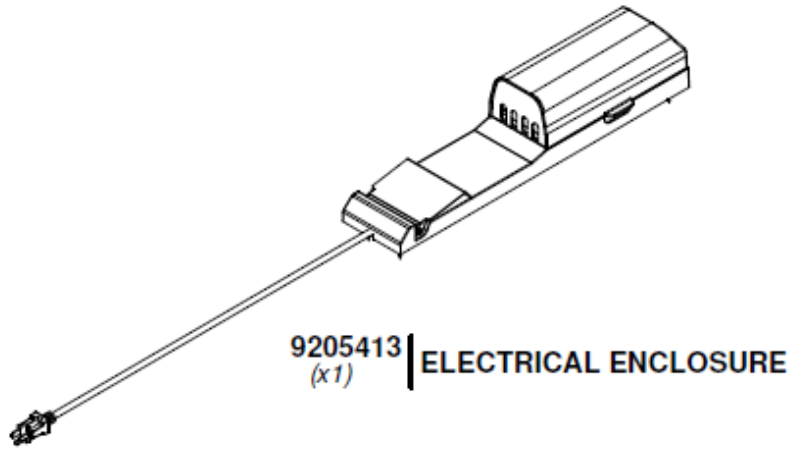

FOR ELECTRICAL ENCLOSURE INSTALLATION REFER TO ASSEMBLY INSTRUCTIONS THAT COMES PACKAGED WITH THE ELECTRICAL ENCLOSURE KIT. INSTALL ON ANY POST THAT IS DESIRED. FOLLOW DIRECTIONS FOR PROPER INSTALLATION.