



Manufactured by:
Backyard Discovery
3305 Airport Drive, Pittsburg, KS 66762
800-856-4445

Basepoint Business Centre: Rivermead Drive, Westlea, Swindon SN5 7EX Phone: 0800-118-2476
J.P. Coenstraat 7, The Bridge, The Hague, 2595 WP, Netherlands Phone: 08005678990

EMORY 9' OUTDOOR KITCHEN ISLAND

MODEL #: 2404441B



WARNING

Cancer and Reproductive Harm
www.P65Warnings.ca.gov



Please visit www.backyarddiscovery.com
For the most up to date assembly manual, to register your product, or to order
replacement parts Para obtener instrucciones en español, visite
www.backyarddiscovery.com



EASY STEP-BY-STEP
3D INTERACTIVE INSTRUCTIONS
DOWNLOAD THE FREE APP



OWNER'S MANUAL - BASIC SETUP DIMENSIONS & ASSEMBLY NOTES

- Pay close attention to the items needed for each step. Make sure you are using the correct hardware for each step. Using incorrect hardware may result in improper assembly
 - Remember to double check for underground utilities and overhead electrical lines
-

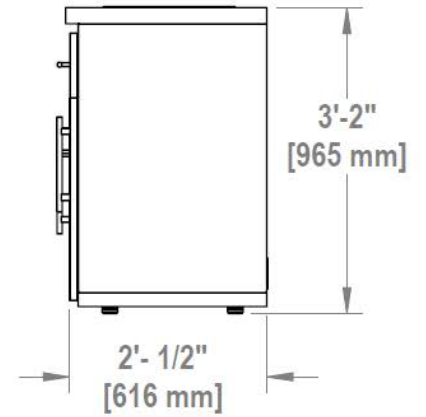
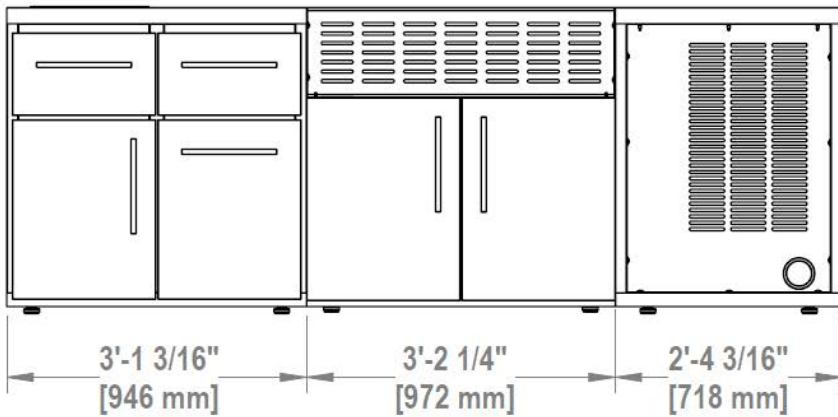
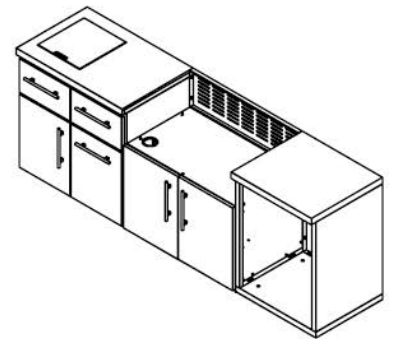
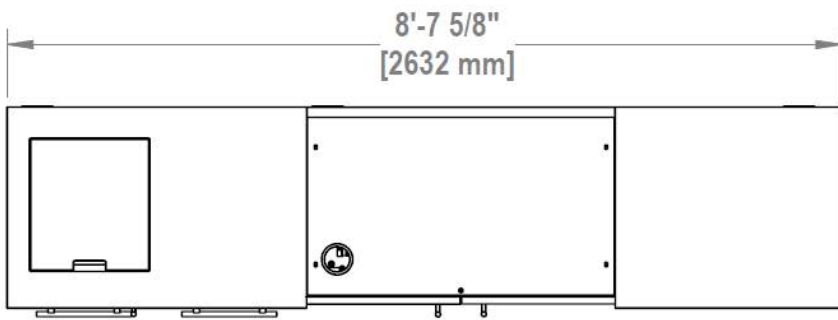

OWNER'S MANUAL - UTILITY LAYOUT

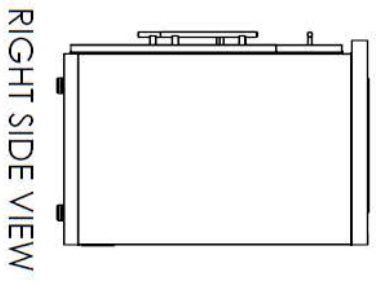
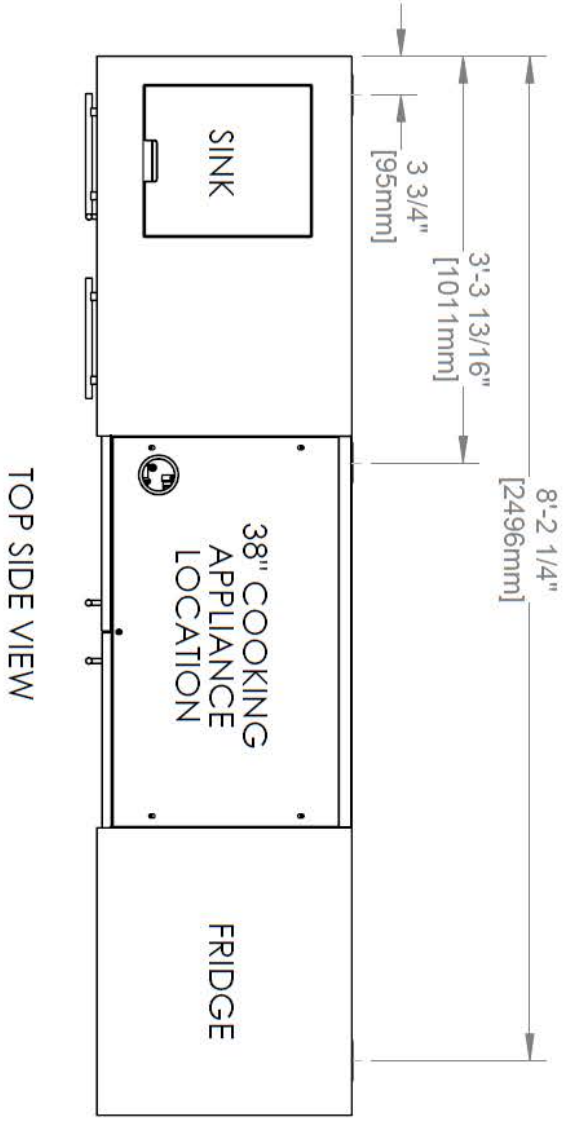
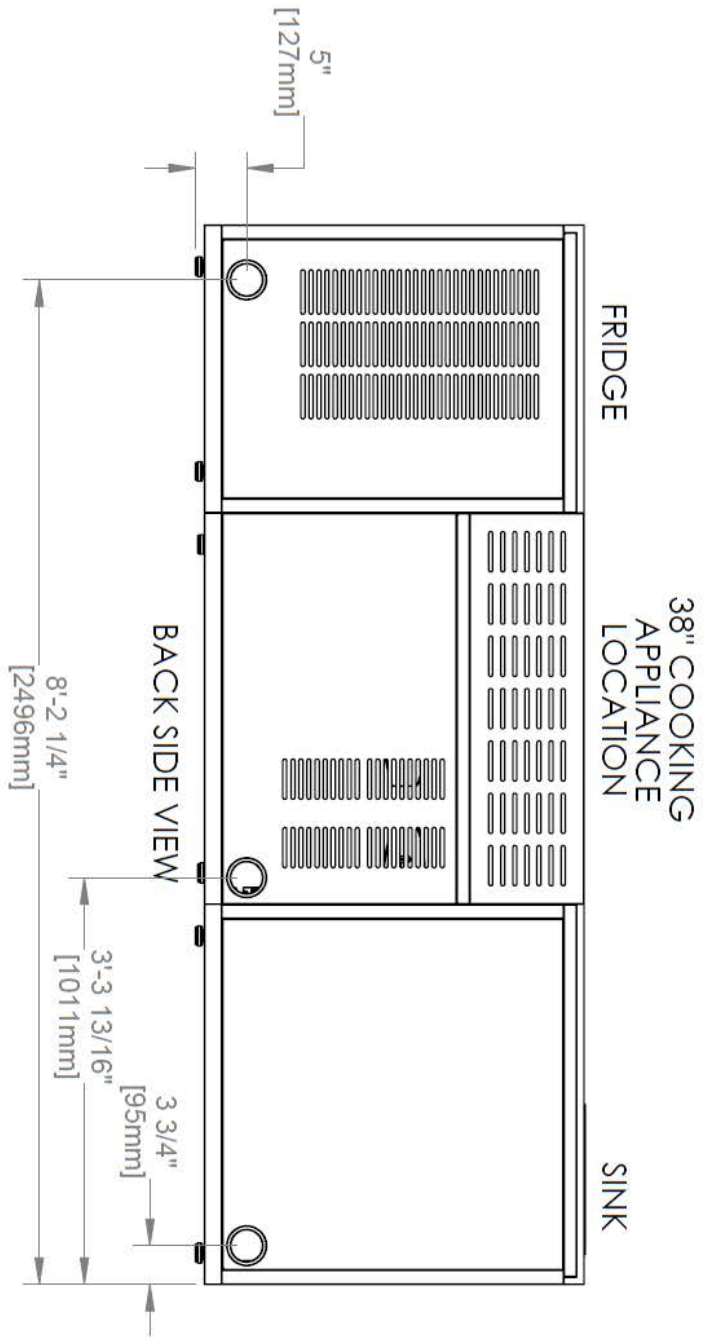

OWNER'S MANUAL - PARTS IDENTIFICATION

METAL COMPONENTS (NOT TO SCALE)

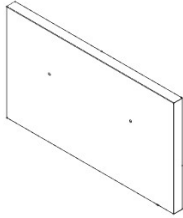

D3 CABINET DRAWER PANEL ASSEMBLY - A4M03569
(x1) 17 3/4"x10 1/4"x15/16" (24x260x451)

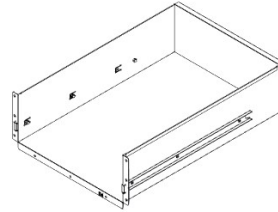

D4 CABINET DRAWER BODY ASSEMBLY - A4M03571
(x1) 22 1/4"x16 1/16"x6 7/16" (164.2x408.4x565.4)

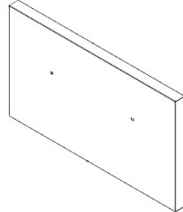

D5 SINK CABINET TRIM PANEL - A4M03576
(x1) 17 13/16"x10 1/4"x1" (26x260x452)

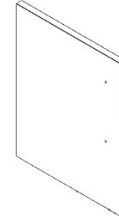

D6 CABINET DOOR ASSEMBLY L - A4M03577
(x1) 22 1/4"x17 13/16"x15/16" (24x452x565)

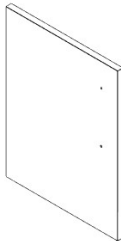

D7 CABINET DOOR ASSEMBLY L - A4M03587
(x1) 24 13/16"x19 1/16"x15/16" (24x484.15x630)



D8 CABINET DOOR ASSEMBLY R - A4M03590
(x1) 24 13/16"x19 1/16"x15/16" (24x484.15x630)

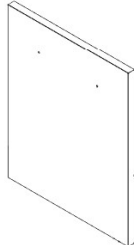

D9 TRASH CAN PANEL ASSEMBLY - A4M03608
(x1) 22 1/4"x17 3/4"x15/16" (24.00x451.00x565.00)

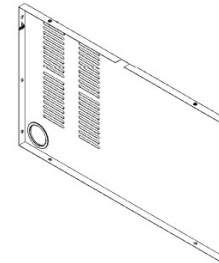

G10 CABINET BACK PANEL ASSEMBLY - A4M03055
(x1) 1 3/16"x22 7/8"x38 3/16" (30x581x970)

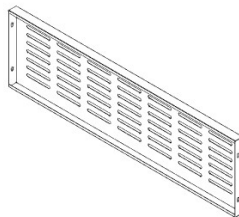

G11 VENTILATION PANEL - A4M03056
(x1) 1 5/16"x11 3/16"x38 3/16" (33x284x970)

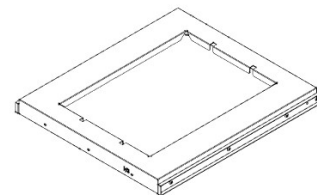

H3 TRASH CAN BRACKET ASSEMBLY - A4M03610
(x1) 18 1/16"x15 13/16"x (35x401.60x458)

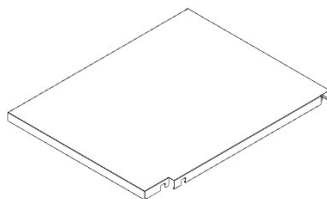

L2 CABINET SHELF ASSEMBLY - A4M03589
(x1) 23 1/4"x18 3/8"x1" (25.00x467.00x591.00)

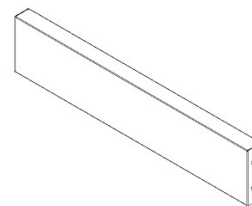

H4 HORIZONTAL BEAM ASSEMBLY - A4M03575
(x4) 16 1/4"x3 3/8"x1" (25x85x413)

OWNER'S MANUAL - PARTS IDENTIFICATION

METAL COMPONENTS (NOT TO SCALE)

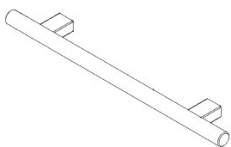

H2 STAINLESS STEEL HANDLE - A4M03024
(x6) 5/8"x1 9/16"x11 13/16" (16x40x300)

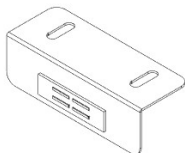

A2 MAGNET BRACKET - A4M03026
(x3) 1"x1 1/4"x3 1/8" (25x31x80)

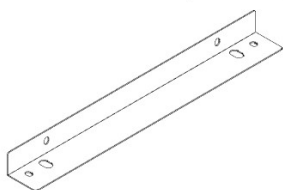

A6 ANGLED BRACKET - A4M03053
(x2) 1 3/8"x1 15/16"x17 1/8" (35x50x435)

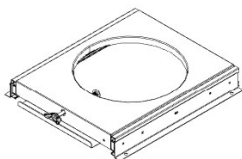

A13 GAS TANK HOLDER ASSEMBLY - A4M03047
(x1) 1 15/16"x12 7/8"x14 3/4" (49x327x374)

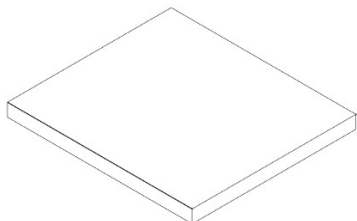

M3 COUNTERTOP - A4M06163
(x1) 28 1/8"x24 15/16"x1 15/16" (50x634x715)

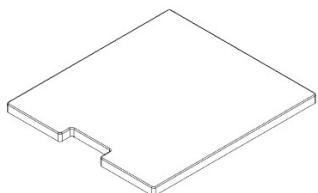

M5 SINK COVER COUNTERTOP - A4M05949
(x1) 11/16"x14 3/4"x16 5/16" (18x375x415)



G3 SINK CABINET BACK PANEL ASSEMBLY - A4M03564
(x1) 34 5/16"x33 3/8"x1 3/16" (30x847.2x872)

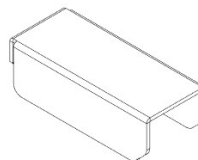

A5 SHELF BRACKET - A4M03141
(x2) 5/8"x7/8"x2 1/16" (16x22x53)

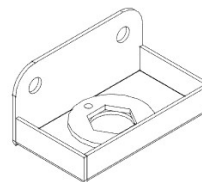

A9 HOSE BRACKET ASSEMBLY - A4M03060
(x1) 1 1/4"x1 7/16"x2 9/16" (31.5x36.5x65)

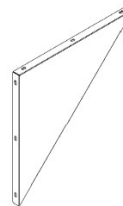

A11 TRIANGLE PANEL - A4M03086
(x2) 13/16"x13 3/4"x13 3/4" (20x350x350)

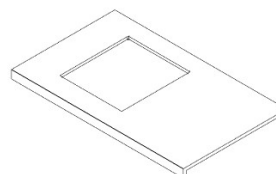

M7 SINK COUNTERTOP - A4M06201
(x1) 37 3/16"x24 15/16"x1 15/16" (50x634x944)

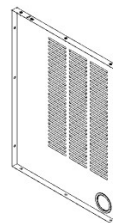

G4 FRIDGE CABINET BACK PANEL ASSEMBLY - A4M03599
(x1) 25 5/16"x33 3/8"x1 3/16" (30x847.2x643)

OWNER'S MANUAL - PARTS IDENTIFICATION

METAL COMPONENTS (NOT TO SCALE)

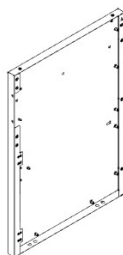

S3 SINK CABINET SIDE PANEL ASSEMBLY L - A4M04538
(x1) 33 3/8"x23 3/8"x2" (50x594x848.2)

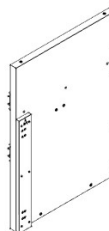

S4 SINK CABINET SIDE PANEL ASSEMBLY R - A4M03563
(x1) 33 3/8"x23 3/8"x2 5/8" (67x594x848.20)

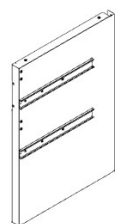

S5 SINK CABINET SIDE PANEL ASSEMBLY M - A4M03567
(x1) 33 3/8"x23 3/8"x2 3/16" (56.2x593x847)

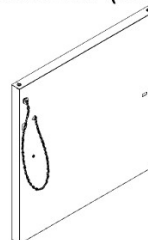

S6 CABINET SIDE PANEL ASSEMBLY M - A4M03586
(x1) 23 3/8"x22 7/8"x1 3/8" (35x581x593)

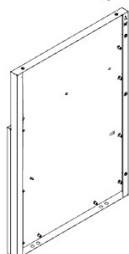

S7 FRIDGE CABINET SIDE PANEL ASSEMBLY L - A4M03597
(x1) 33 7/16"x23 3/8"x2 1/16" (53x594x849.7)

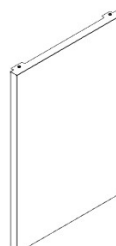

S8 FRIDGE CABINET SIDE PANEL ASSEMBLY R - A4M04535
(x1) 33 3/8"x23 3/8"x1 15/16" (50x594x848.20)

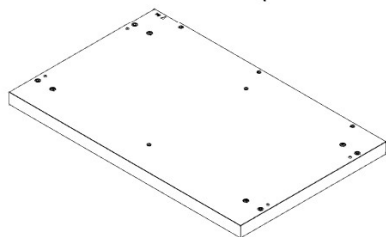

F3 SINK CABINET FLOOR PANEL ASSEMBLY - A4M03560
(x1) 37 3/16"x23 3/8"x2 5/8" (66x594x944)

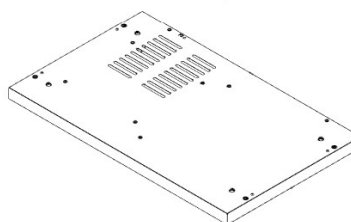

F2 CABINET FLOOR PANEL ASSEMBLY - A4M03048
(x1) 2 5/8"x23 3/8"x38 1/4" (66x594x972)

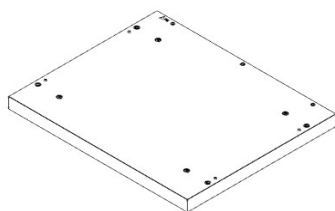

F4 FRIDGE CABINET FLOOR PANEL ASSEMBLY - A4M03595
(x1) 28 1/8"x23 3/8"x2 5/8" (66x594x715)

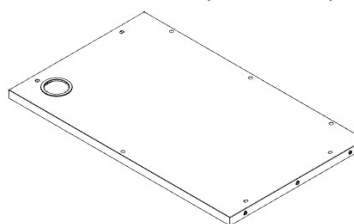

T2 TABLETOP ASSEMBLY - A4M03057
(x1) 1 1/4"x23 3/8"x38 3/16" (32x594x970)

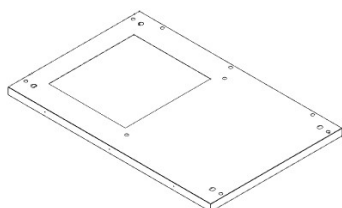

T4 SINK CABINET TABLETOP FRAME - A4M04540
(x1) 36 3/8"x24 1/8"x1 1/4" (32x612x925)

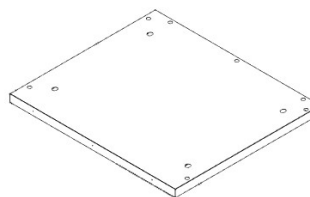

T7 FRIDGE CABINET TABLETOP - A4M03641
(x1) 27 3/8"x24 1/8"x1 1/4" (32x612x696)

OWNER'S MANUAL - PARTS IDENTIFICATION

METAL COMPONENTS (NOT TO SCALE)

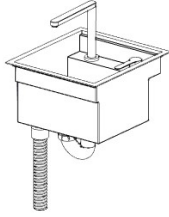

A16 SINK ASSEMBLY - A4M03143
(x1) 15 1/8"x15 5/16"x16 7/8" (384x389x429)

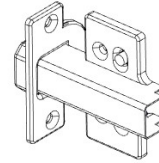

A4M03025 FULL OVERLAY HINGE
(x6)

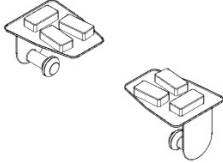

A4M02290 MAGNETIC PAPER TOWEL HOLDER
(x1)



A4M03151 GARDEN HOSE ADAPTER
(x1)

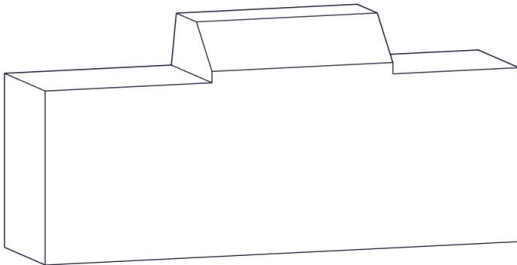

A6P01386 OUTDOOR KITCHEN CABINET COVER
(x1)

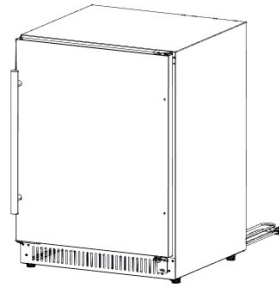

9240162 OUTDOOR KITCHEN FRIDGE - RIGHT OPEN
(x1)

OWNER'S MANUAL - PARTS IDENTIFICATION

HARDWARE COMPONENTS

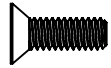

H101185 | PHILLIPS FLAT HEAD
(x36) | 8-32x.5 SCREW

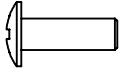

H101289 | PAN HEAD SCREW
(x35) | 8-32x1/2" SS

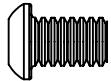

H101292 | TORX PAN HEAD
(x12) | 1/4-20x13/32"

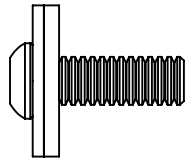

H101202 | TORX PAN HEAD
(x82) | 1/4-20x3/4 ASSY

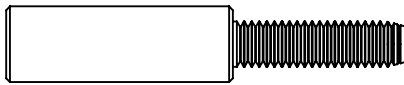

H101103 | TORX SOCKET SCREW
(x20) |

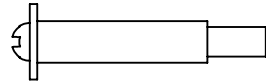

H101307 | SHOULD BOLT
(x10) | 8-32x30mm SS

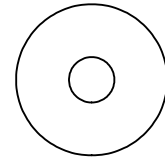

H101054 | SEALANT WASHER
(x8) |

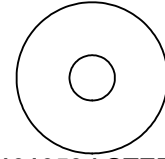

H101053 | STEEL WASHER
(x8) | 6x20

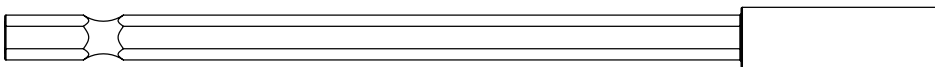

H101278 | 6" MAGNETIC DRIVER EXTENSION
(x1)

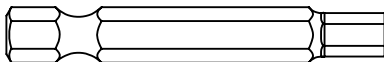

H101294 | HEX DRIVER
(x1)

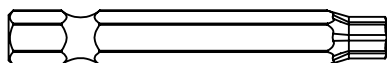

H100147 | TORX BIT
(x1) T-30

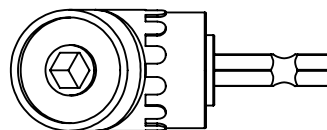

H101114 | RIGHT ANGLE DRILL ADAPTER
(x1) |

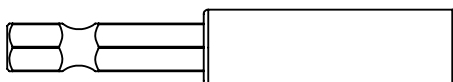

H101100 | MAGNETIC DRIVER
(x1)

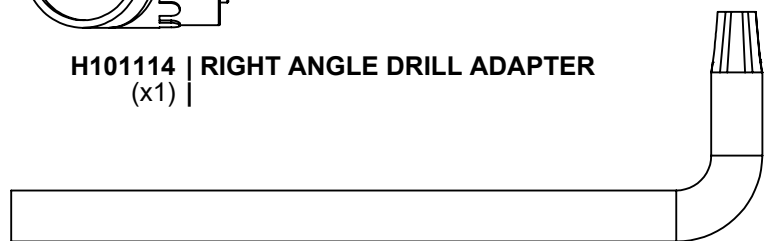

H100114 | TORX WRENCH
(x1) | T-30

PRE-ASSEMBLY STEP 1 - SORTING PARTS

It is critical for ease of assembly that you take the time to sort and organize the parts and hardware.

METAL PARTS:

- Organize metal parts by the three-digit, alpha-numeric number stamped on each part (ex. P01).
- If there are multiple parts with the same stamped number, stack those pieces together.
- Stamps can be found on the flat surface of the parts or on the end of the parts.
- Allow yourself plenty of room - the parts can take up a significant amount of space.

NOTE: CARTONS ARE NOT ORGANIZED BY PART OR STEP NUMBER.

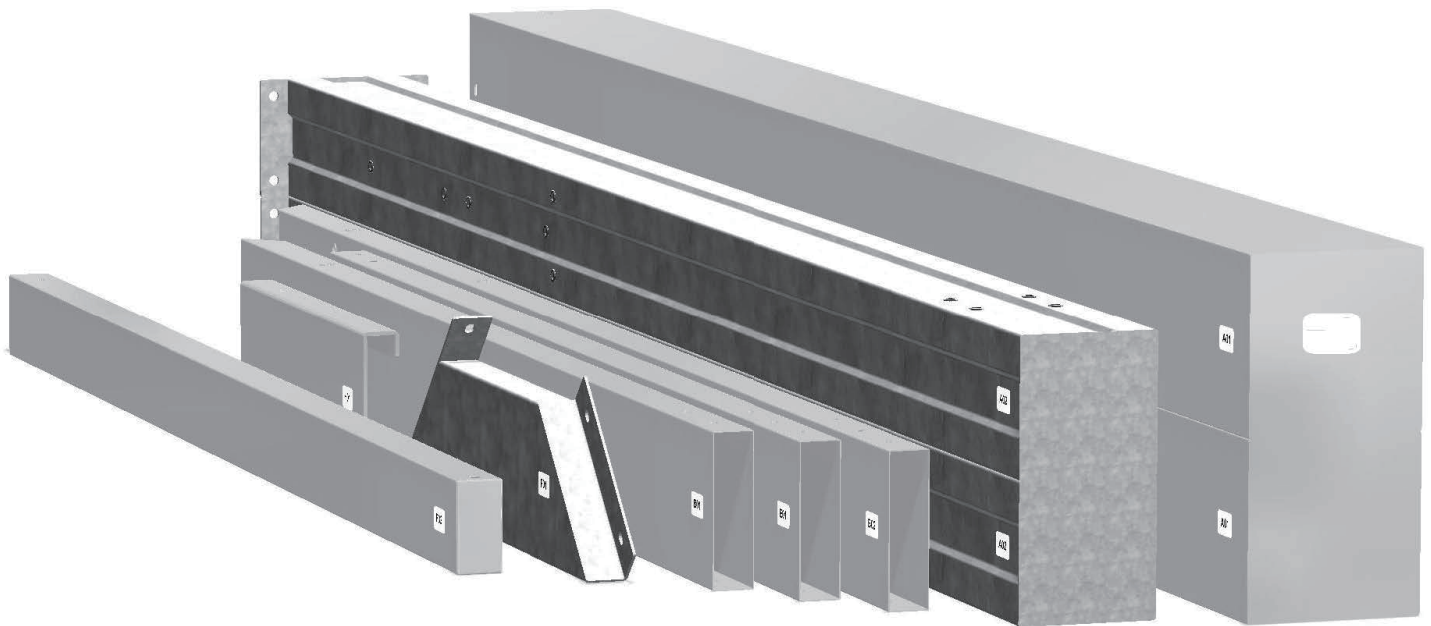

HARDWARE PARTS:

- We recommend that you have a separate table to organize the hardware.
- Hardware bags are printed with a seven-digit, alpha-numeric part number.
- You can organize your hardware by part number or group by hardware type (e.g. bolts, nuts, etc.).
- During assembly you only need to reference the last four digits of the number.

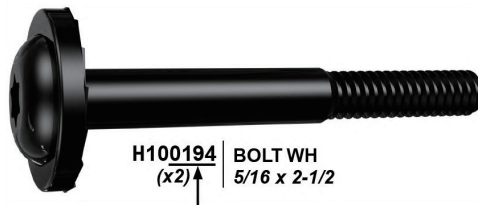

PRE-ASSEMBLY STEP 2 - TOOLS REQUIRED



Cordless Drill or
Electric Drill



Drill Attachments:
Phillips Head



1/8", 3/16", 3/8" &
7/16" Drill Bits



Phillips Screw Driver

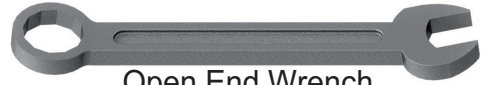

Open End Wrench
7/16"



3/8" Drive Ratchet, 1/2" &
7/16" STD Sockets 1/2" & 7/16"
Deep Sockets



Claw Hammer

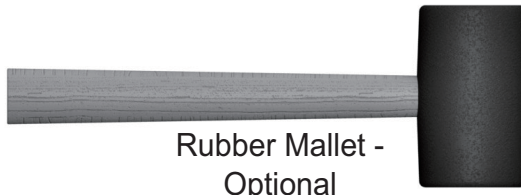

Rubber Mallet -
Optional

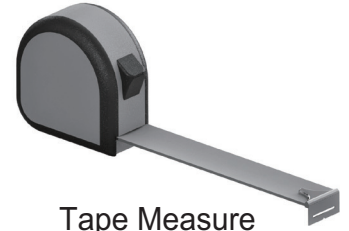

Tape Measure

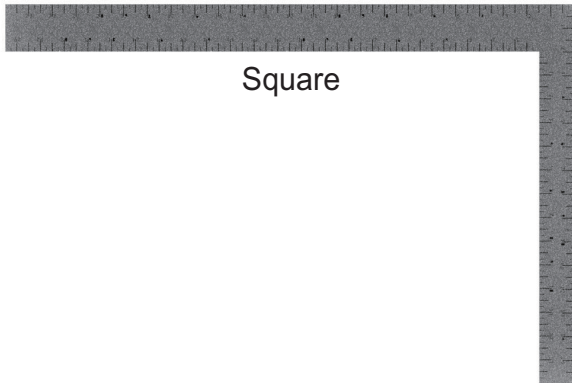

Square



Level 24"

PRE-ASSEMBLY STEP 3 - CHOOSE YOUR ASSEMBLY METHOD

There are several types of assembly instructions available to you.

1. Printed Assembly Manual included with your set
2. BILT APP - 3D interactive instructions
3. Combination of the Printed Manual and BILT APP (Note: Step numbers can differ between the two methods)

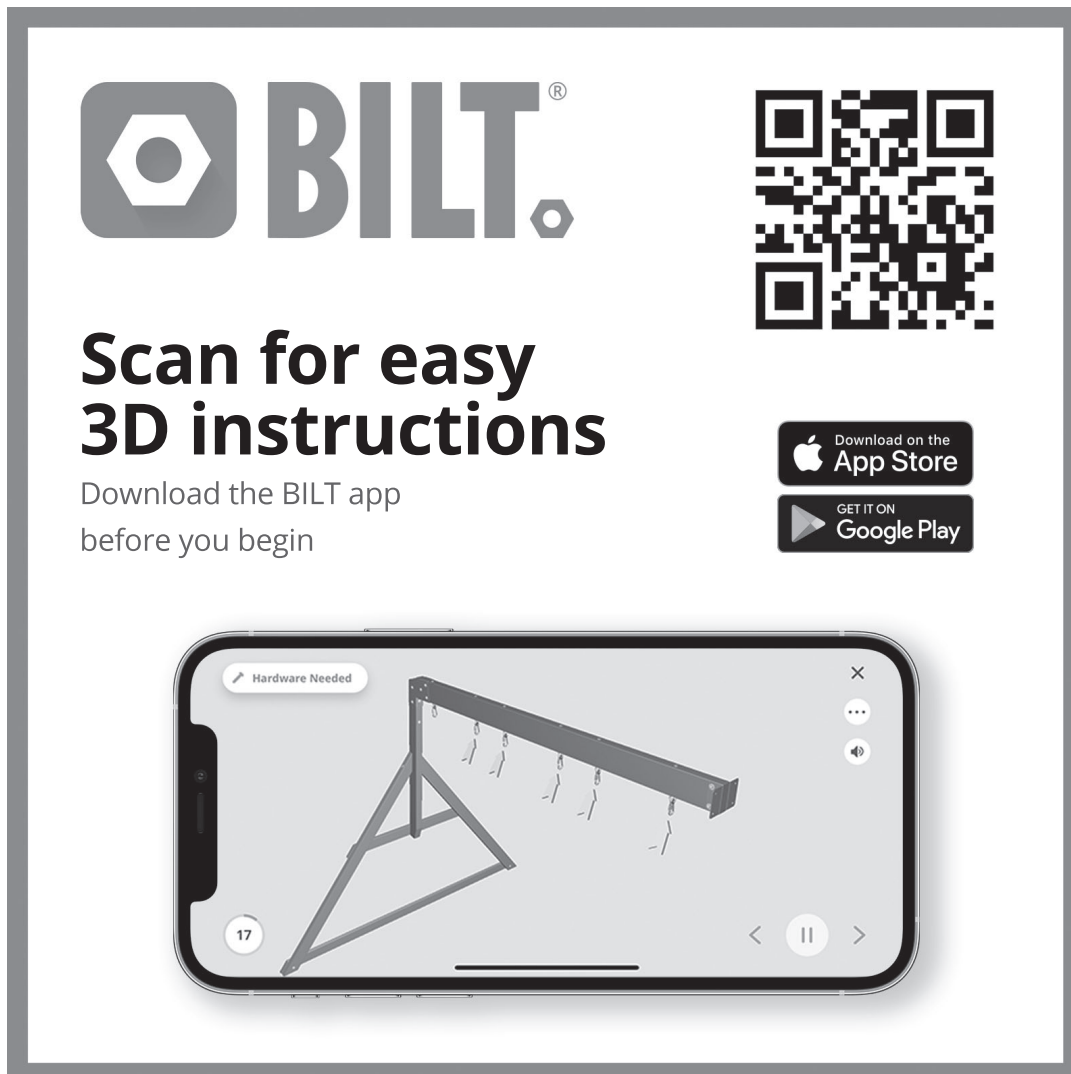

The graphic features the BILT logo (a hexagon with a dot) and the word "BILT." in a large, bold, sans-serif font. To the right is a large QR code. Below the logo, the text "Scan for easy 3D instructions" is written in a large, bold font, followed by "Download the BILT app before you begin" in a smaller font. To the right of this text are two buttons: "Download on the App Store" and "GET IT ON Google Play". At the bottom is a smartphone displaying a 3D assembly instruction interface. The interface shows a 3D model of a metal frame with a horizontal bar and several hanging components. The interface includes a "Hardware Needed" button at the top left, a close button (X) at the top right, a menu button (three dots) and a volume icon below it, and a page number "17" in a circle at the bottom left. At the bottom right of the screen are navigation arrows and a pause button.

STEP 1 - FRIDGE CABINET ASSEMBLY

Qty	PartNo	Description
2	H101202	TORX PAN HEAD 1/4-20x3/4 ASSY

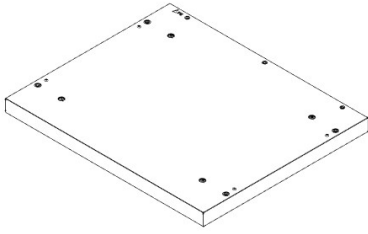

F4 FRIDGE CABINET FLOOR PANEL ASSEMBLY - A4M03595
(x1) 28 1/8"x23 3/8"x2 5/8" (66x594x715)

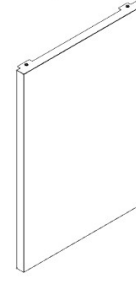

S8 FRIDGE CABINET SIDE PANEL ASSEMBLY R - A4M04535
(x1) 33 3/8"x23 3/8"x1 15/16" (50x594x848.20)

- POSITION FLOOR PANEL IN THE PROXIMITY OF WHERE YOUR KITCHEN WILL BE.
- EACH FLOOR PANEL HAS FACTORY INSTALLED ADJUSTABLE FEET. USE PROVIDED HEX DRIVER TO ADJUST EACH FOOT UNTIL PANEL IS LEVEL.

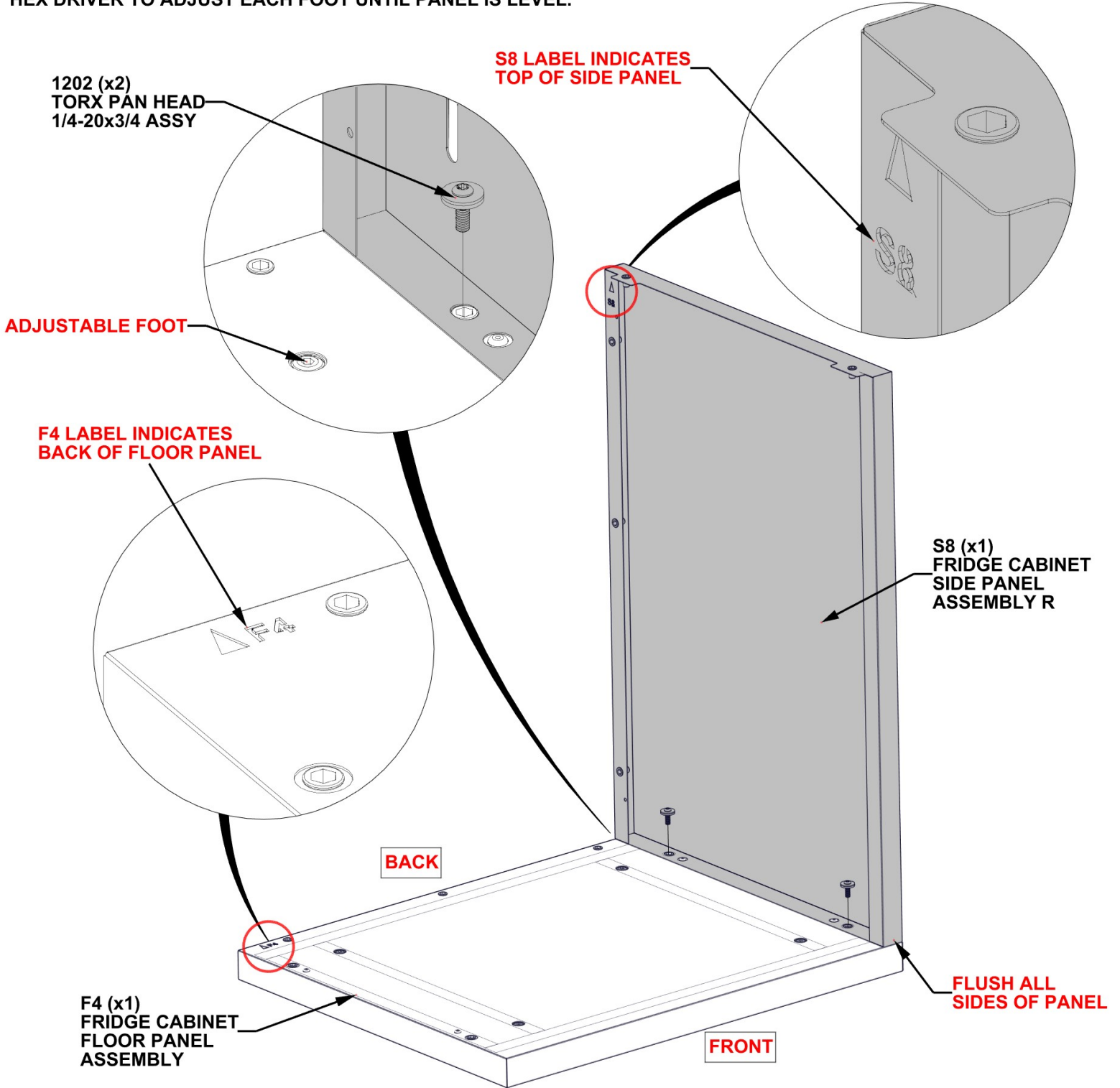

STEP 2 - FRIDGE CABINET ASSEMBLY

Qty	PartNo	Description
2	H101202	TORX PAN HEAD 1/4-20x3/4 ASSY

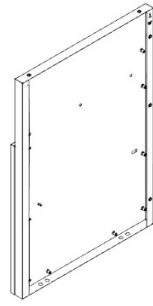

S7 FRIDGE CABINET SIDE PANEL ASSEMBLY L - A4M03597
 (x1) 33 7/16"x23 3/8"x2 1/16" (53x594x849.7)

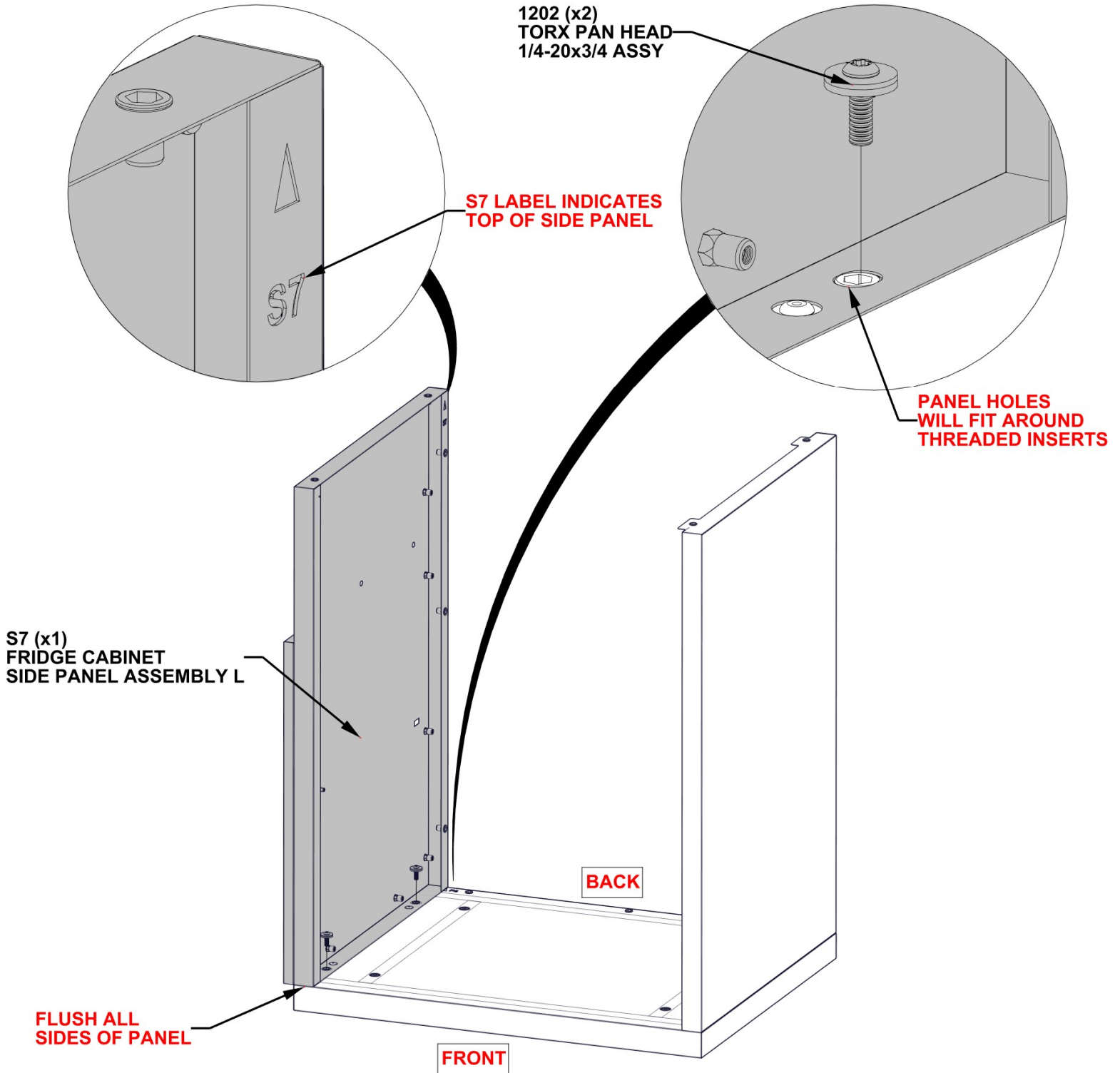

STEP 3 - FRIDGE CABINET ASSEMBLY

Qty	PartNo	Description
9	H101202	TORX PAN HEAD 1/4-20x3/4 ASSY

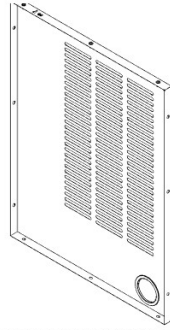

G4 FRIDGE CABINET BACK PANEL ASSEMBLY - A4M03599
(x1) 25 5/16"x33 3/8"x1 3/16" (30x847.2x643)

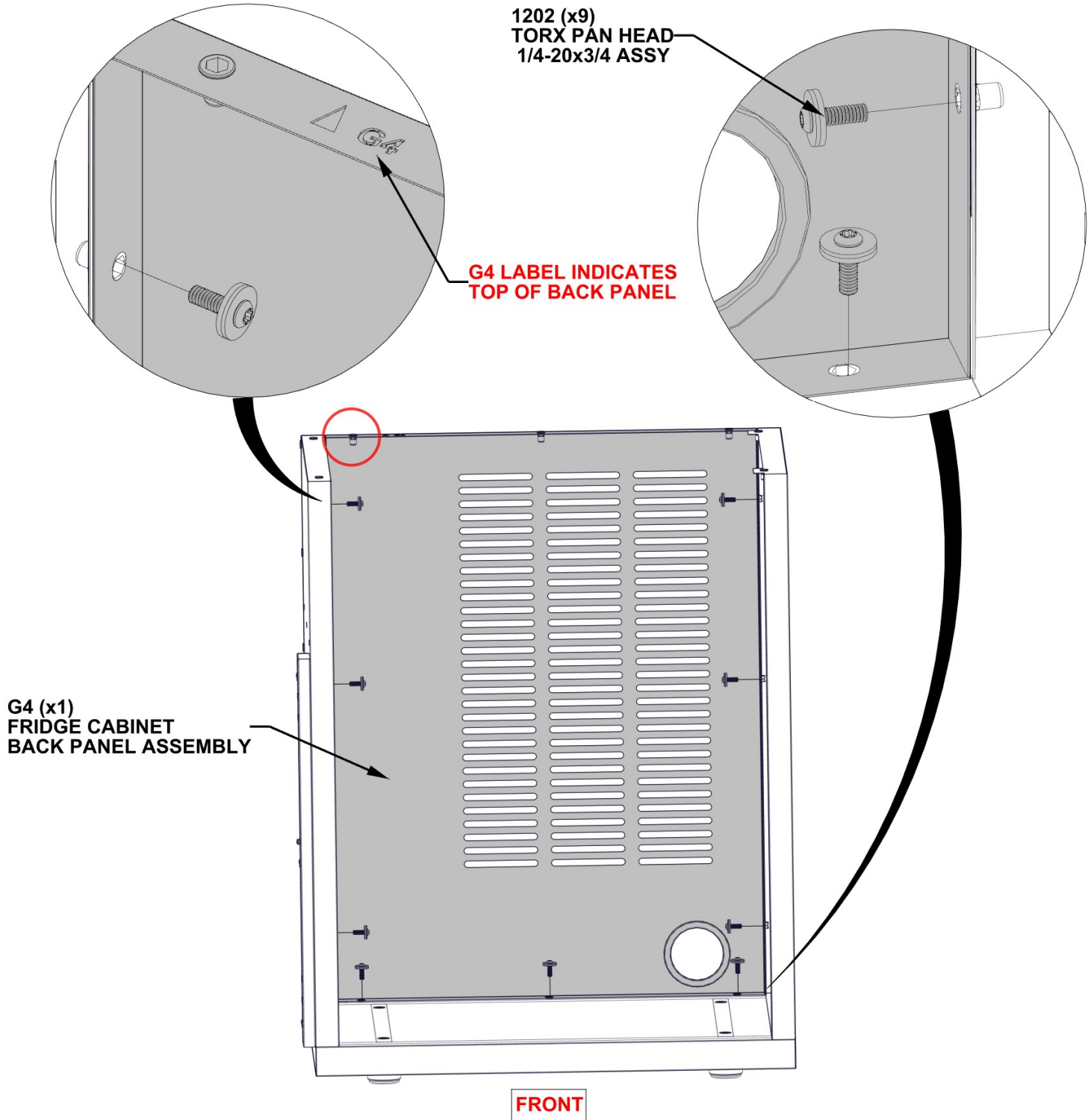

STEP 4 - FRIDGE CABINET ASSEMBLY

Qty	PartNo	Description
7	H101103	TORX SOCKET SCREW 1/4-20

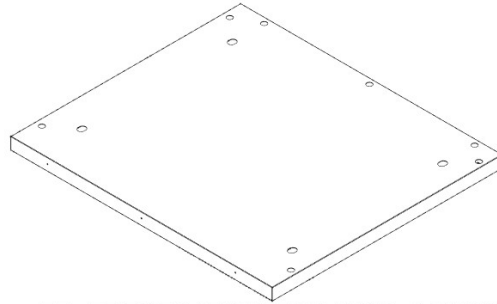

T7 FRIDGE CABINET TABLETOP - A4M03641
(x1) 27 3/8"x24 1/8"x1 1/4" (32x612x696)

- FLUSH BACK AND SIDES OF PANEL ASSEMBLY.
- SQUARE ALL SIDES OF CABINET BEFORE TIGHTENING HARDWARE.

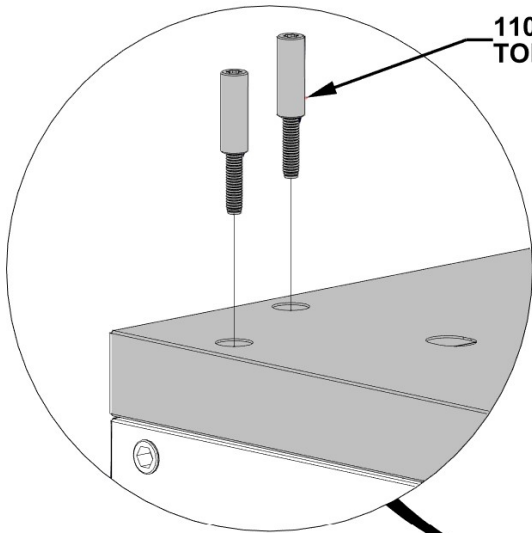

1103 (x7)
TORX SOCKET SCREW 1/4-20

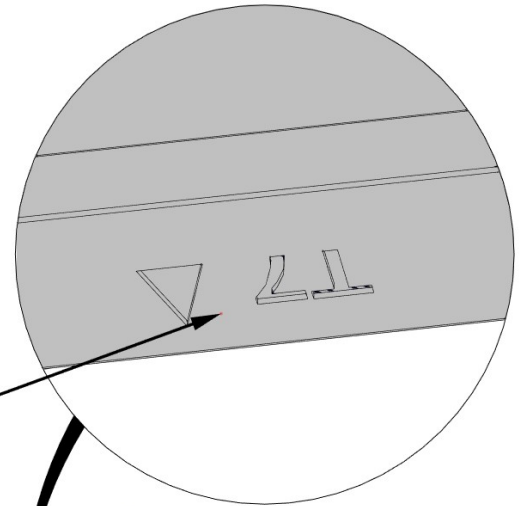

T7 LABEL ON BOTTOM
SIDE INDICATES BACK

T7 (x1)
FRIDGE CABINET TABLETOP

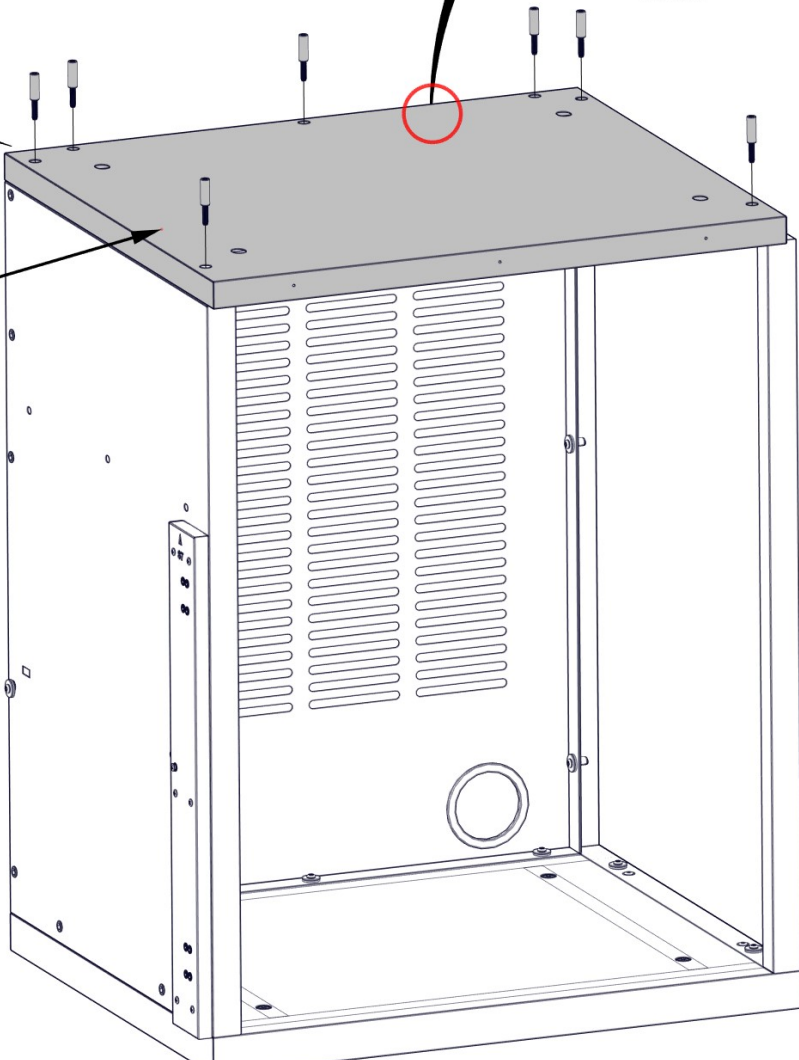

STEP 5 - SINK CABINET ASSEMBLY

Qty	PartNo	Description
2	H101202	TORX PAN HEAD 1/4-20x3/4 ASSY

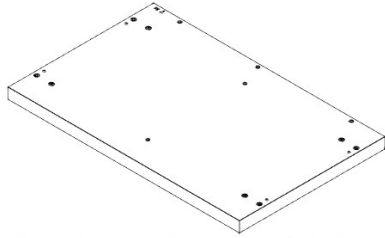

F3 SINK CABINET FLOOR PANEL ASSEMBLY - A4M03560
(x1) 37 3/16"x23 3/8"x2 5/8" (66x594x944)

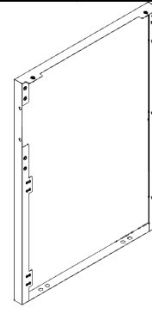

S3 SINK CABINET SIDE PANEL ASSEMBLY L - A4M04538
(x1) 33 3/8"x23 3/8"x2" (50x594x848.2)

- POSITION FLOOR PANEL IN THE PROXIMITY OF WHERE YOUR KITCHEN WILL BE.
- EACH FLOOR PANEL HAS FACTORY INSTALLED ADJUSTABLE FEET. USE PROVIDED HEX DRIVER TO ADJUST EACH FOOT UNTIL PANEL IS LEVEL.

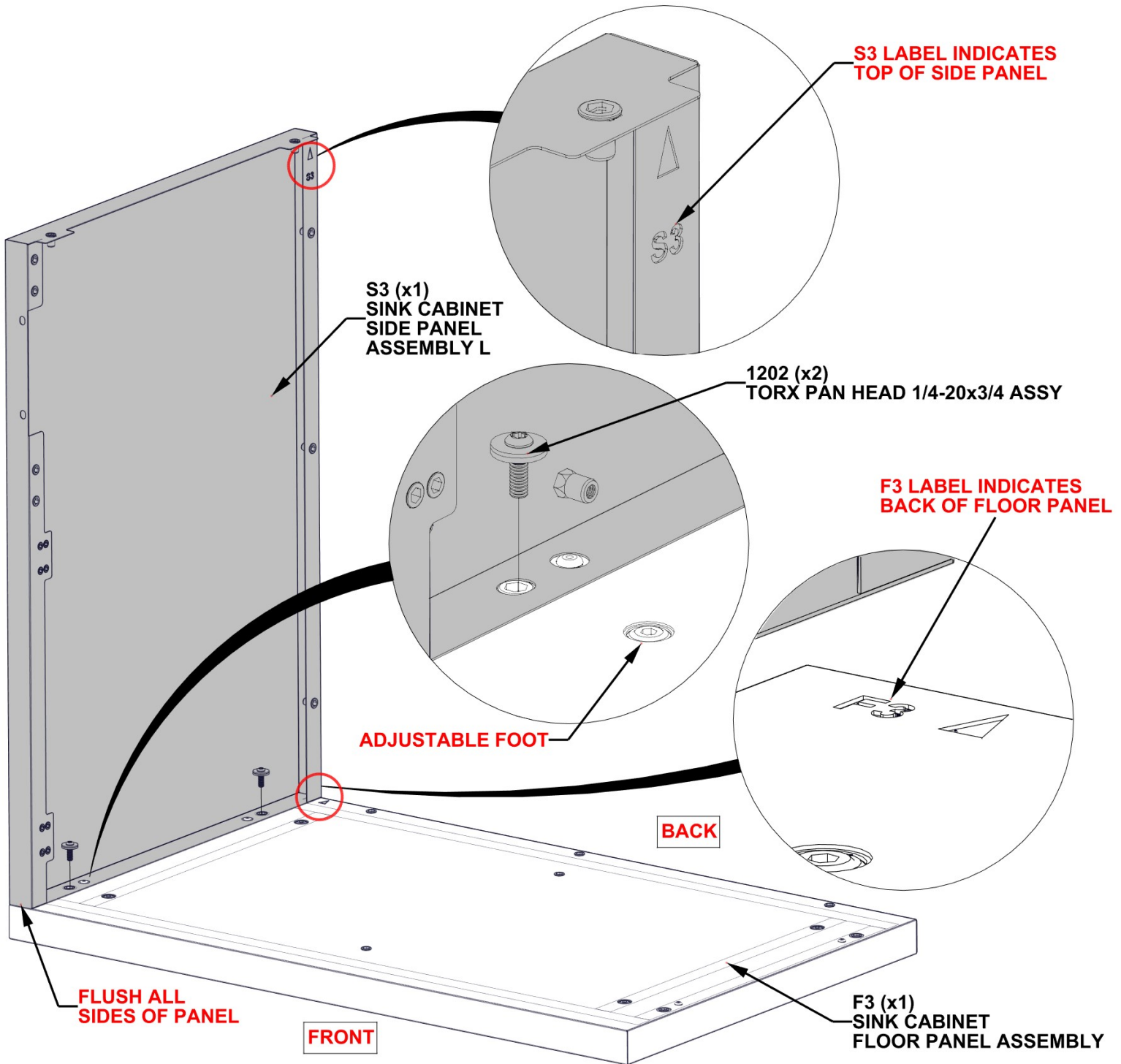

STEP 6 - SINK CABINET ASSEMBLY

Qty	PartNo	Description
2	H101202	TORX PAN HEAD 1/4-20x3/4 ASSY

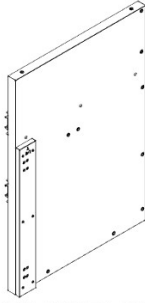

S4 SINK CABINET SIDE PANEL ASSEMBLY R - A4M03563
 (x1) 33 3/8"x23 3/8"x2 5/8" (67x594x848.20)

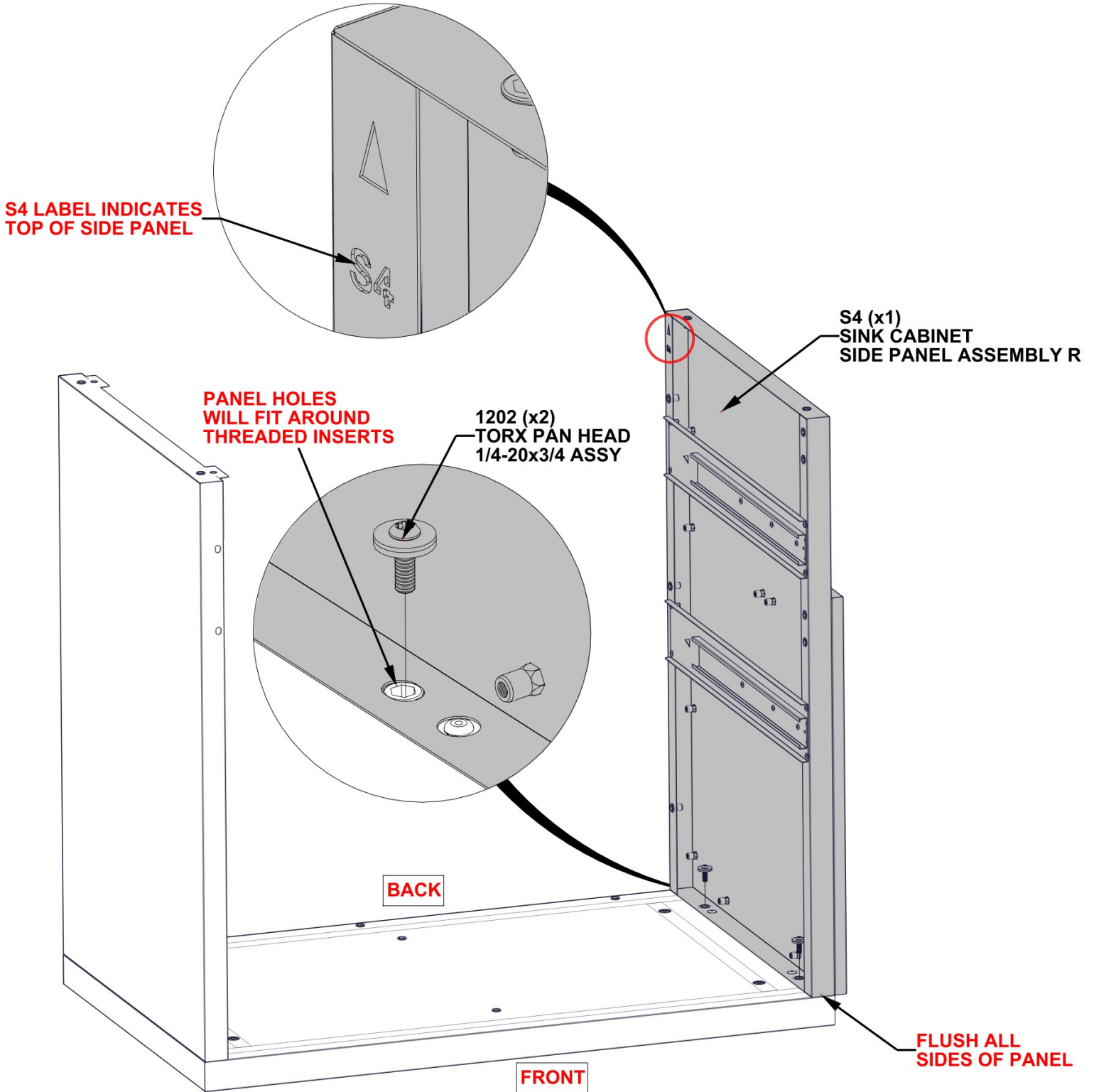

STEP 7 - SINK CABINET ASSEMBLY

Qty	PartNo	Description
9	H101202	TORX PAN HEAD 1/4-20x3/4 ASSY

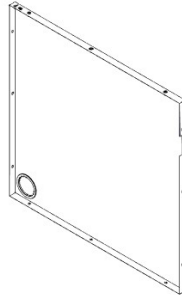

G3 SINK CABINET BACK PANEL ASSEMBLY - A4M03564
 (x1) 34 5/16"x33 3/8"x1 3/16" (30x847.2x872)

G3 LABEL INDICATES TOP OF BACK PANEL

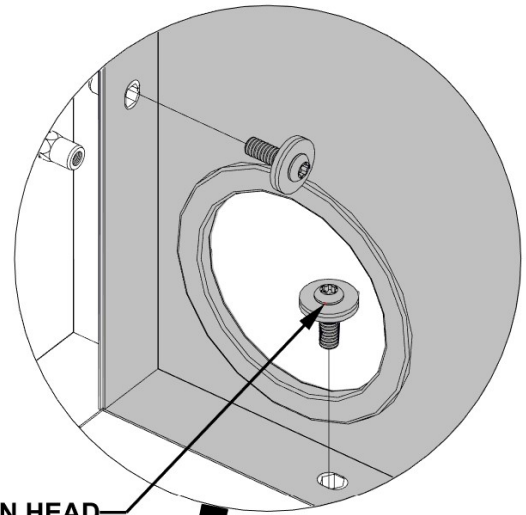
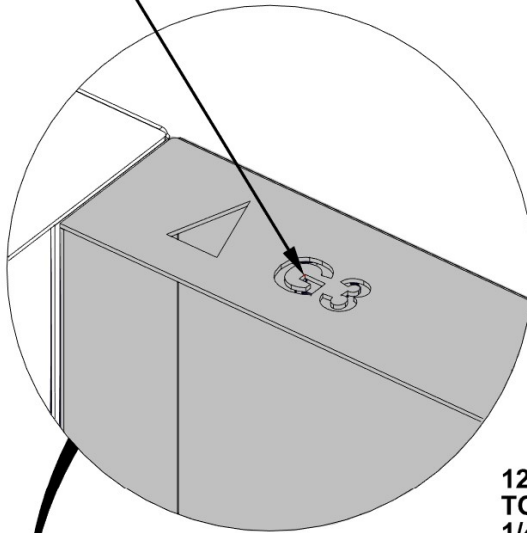

**1202 (x9)
 TORX PAN HEAD
 1/4-20x3/4 ASSY**

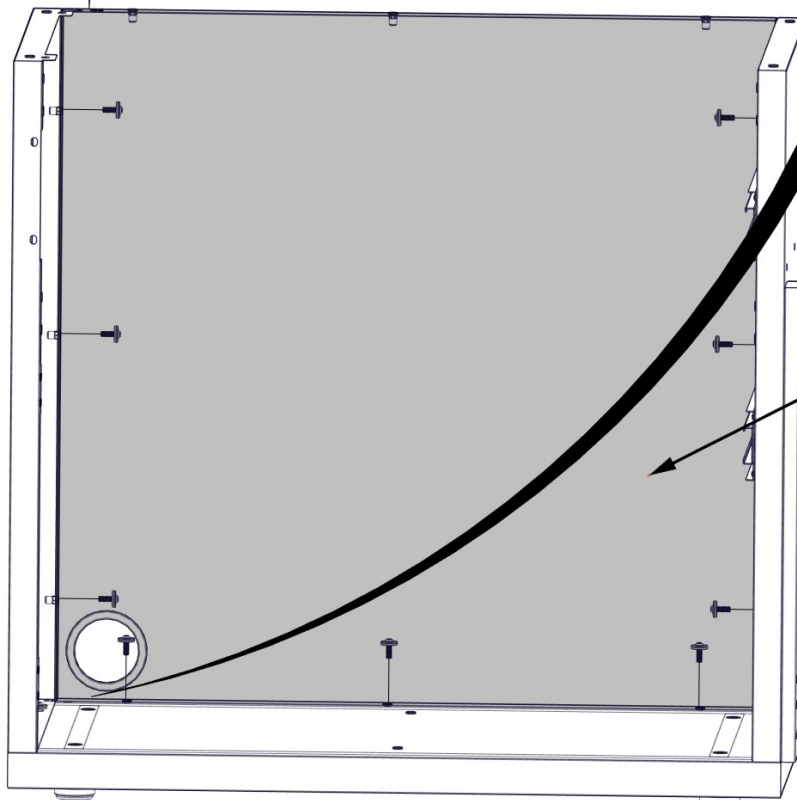

**G3 (x1)
 SINK CABINET BACK
 PANEL ASSEMBLY**

FRONT

STEP 8 - SINK CABINET ASSEMBLY

Qty	PartNo	Description
2	H101202	TORX PAN HEAD 1/4-20x3/4 ASSY

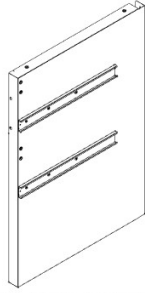

S5 SINK CABINET SIDE PANEL ASSEMBLY M - A4M03567
 (x1) 33 3/8"x23 3/8"x2 3/16" (56.2x593x847)

1202 (x2)
 TORX PAN HEAD
 1/4-20x3/4 ASSY

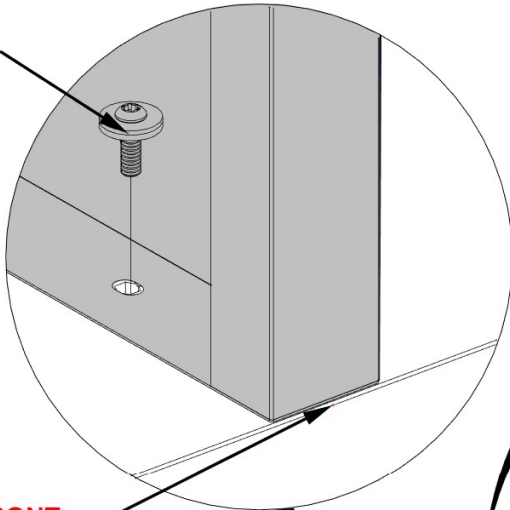

**FLUSH FRONT
 SURFACE**

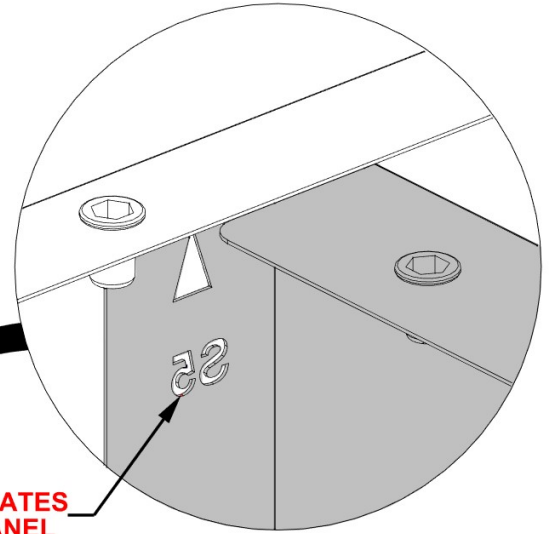

**S5 LABEL INDICATES
 TOP OF SIDE PANEL**

**S5 (x1)
 SINK CABINET SIDE
 PANEL ASSEMBLY M**

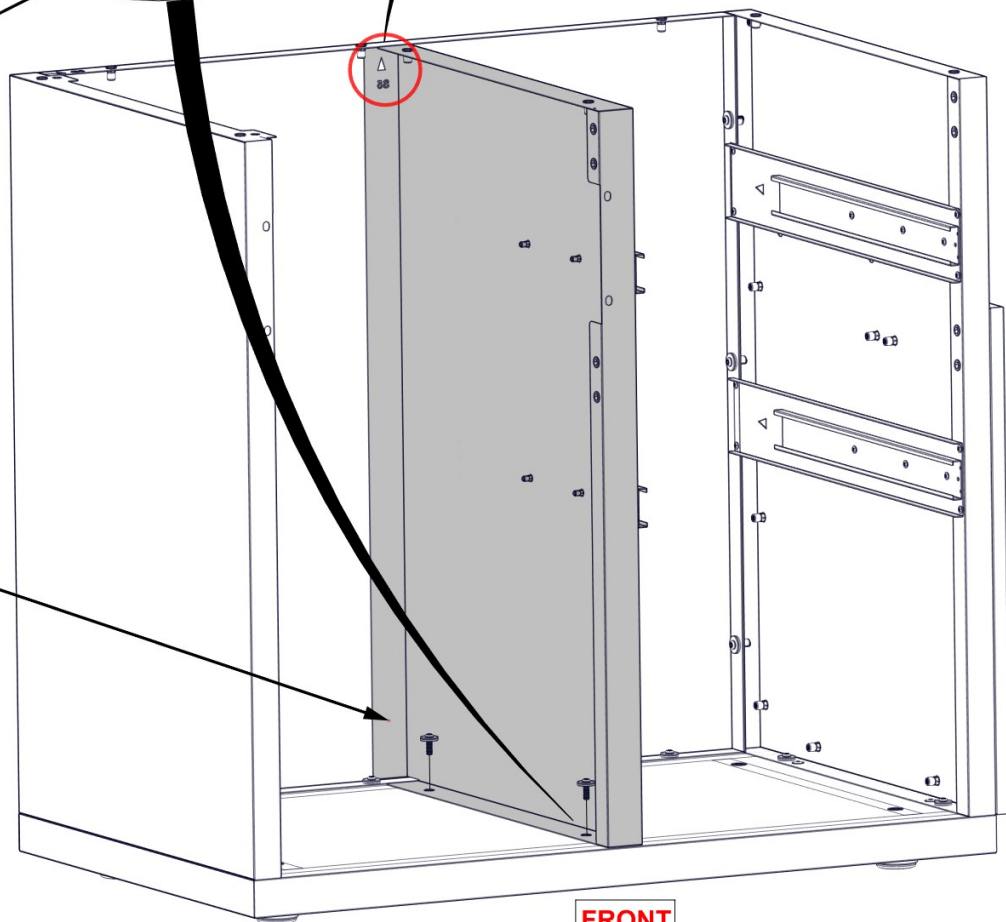

FRONT

STEP 9 - SINK CABINET ASSEMBLY

Qty	PartNo	Description
16	H101202	TORX PAN HEAD 1/4-20x3/4 ASSY

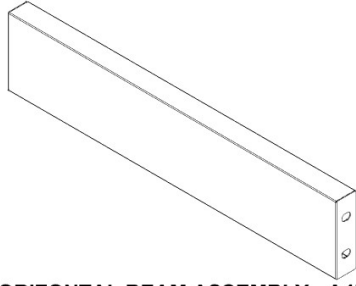

H4 HORIZONTAL BEAM ASSEMBLY - A4M03575
(x4) 16 1/4"x3 3/8"x1" (25x85x413)

- HARDWARE ATTACHES ON INSIDE OF CABINET

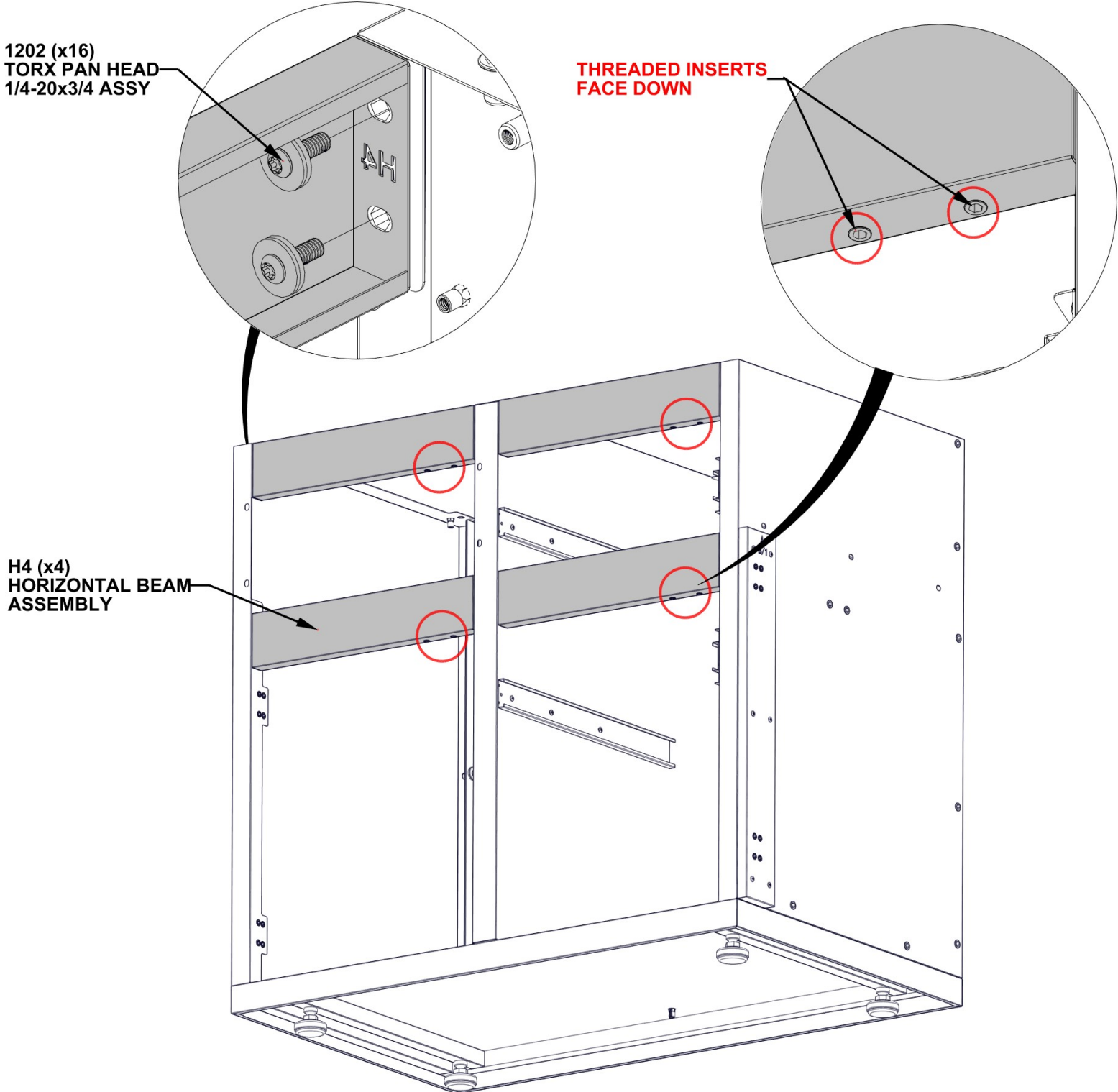

STEP 10 - SINK CABINET ASSEMBLY

Qty	PartNo	Description
2	H101289	PAN HEAD SCREW 8-32x1/2" SS

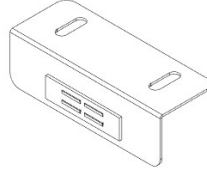

A2 MAGNET BRACKET - A4M03026
(x1) 1"x1 1/4"x3 1/8" (25x31x80)

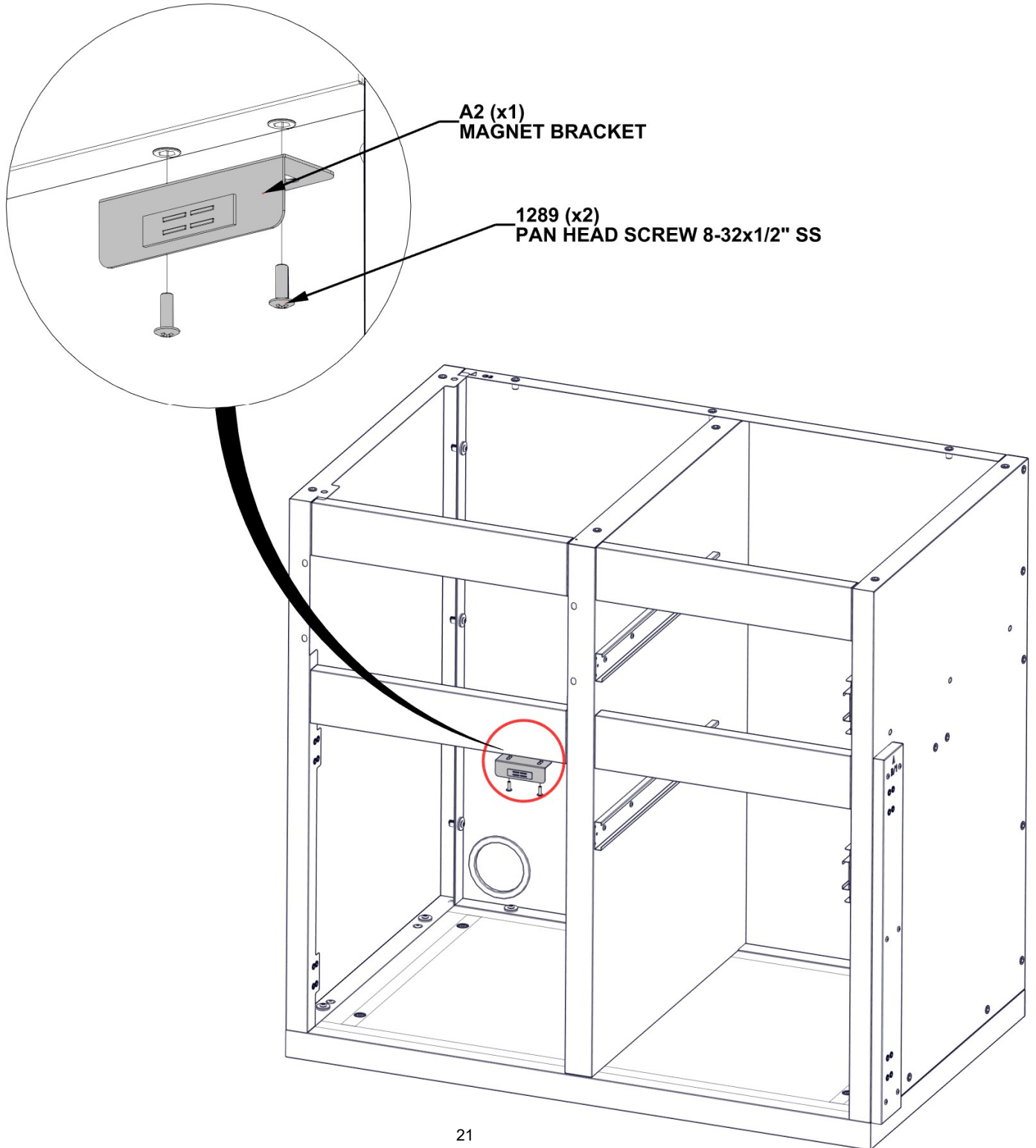

A2 (x1)
MAGNET BRACKET

1289 (x2)
PAN HEAD SCREW 8-32x1/2" SS

STEP 11 - SINK CABINET ASSEMBLY

Qty	PartNo	Description
9	H101103	TORX SOCKET SCREW 1/4-20

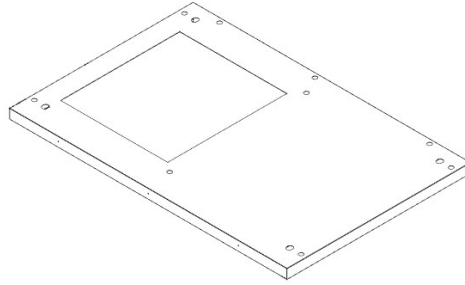

T4 SINK CABINET TABLETOP FRAME - A4M04540
(x1) 36 3/8"x24 1/8"x1 1/4" (32x612x925)

- FLUSH BACK AND SIDE OF PANEL ASSEMBLY.
- **SQUARE ALL SIDES OF CABINET BEFORE TIGHTENING HARDWARE.**

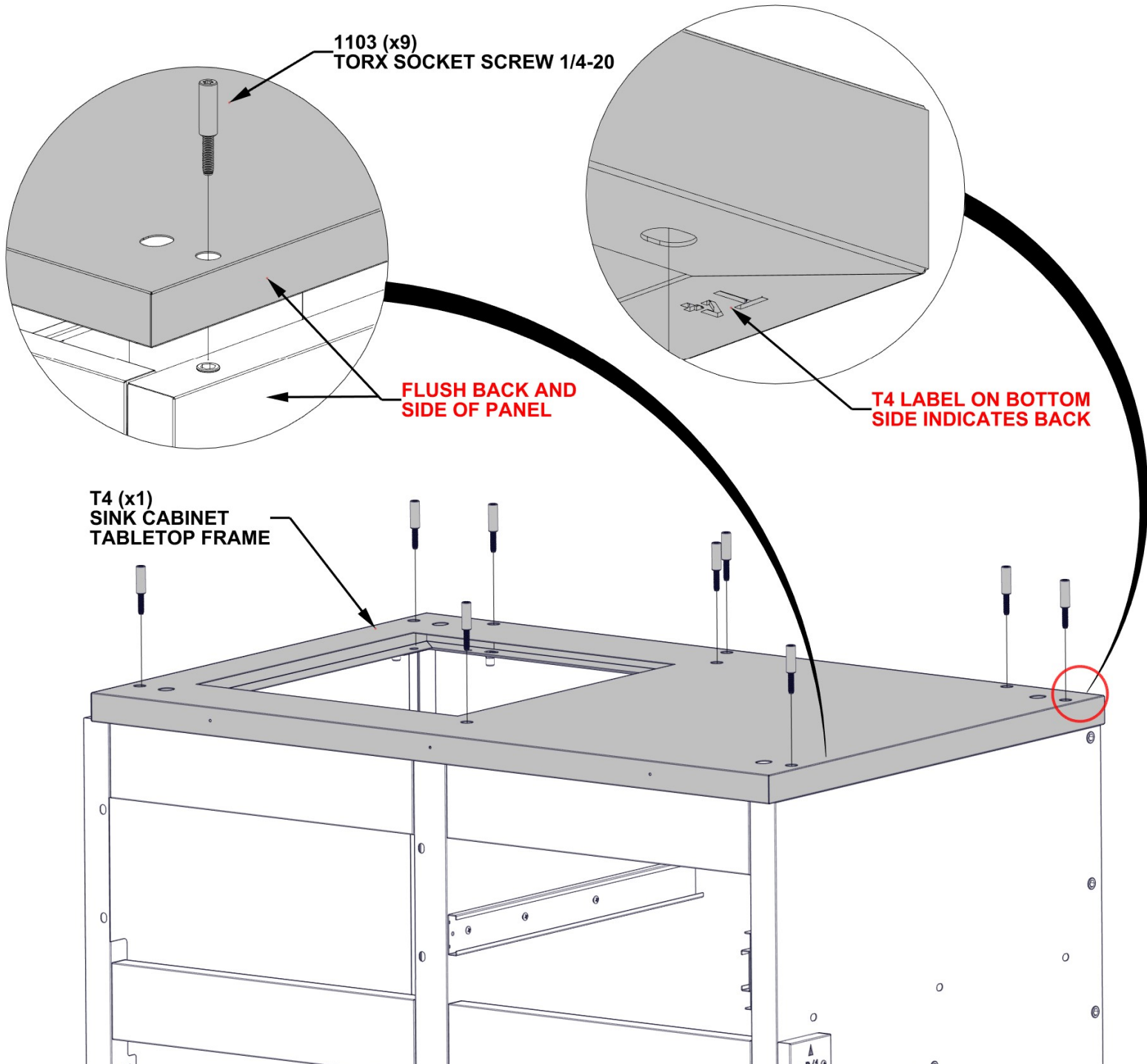

STEP 12 - SINK CABINET INSTALLATION

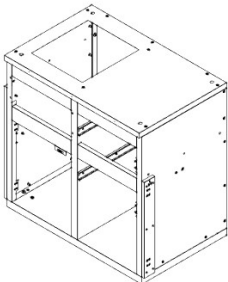

SINK CABINET FROM
STEPS 5 - 11

- POSITION SINK CABINET ASSEMBLY ON THE LEFT SIDE OF FRIDGE CABINET.
- DISTANCE BETWEEN FRIDGE CABINET WILL BE DETERMINED IN NEXT STEP.

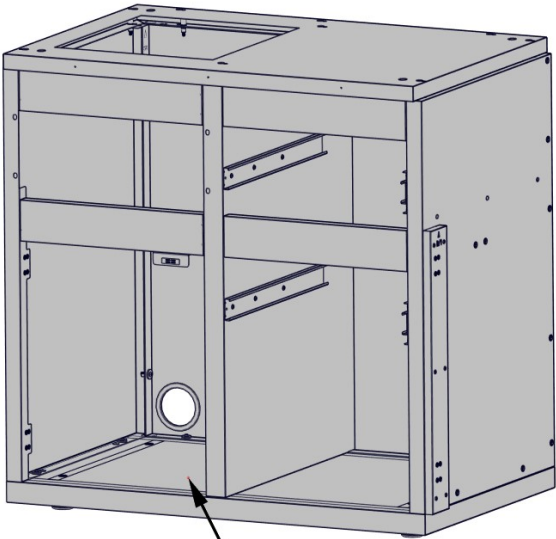

SINK CABINET
FROM STEPS 5 - 11

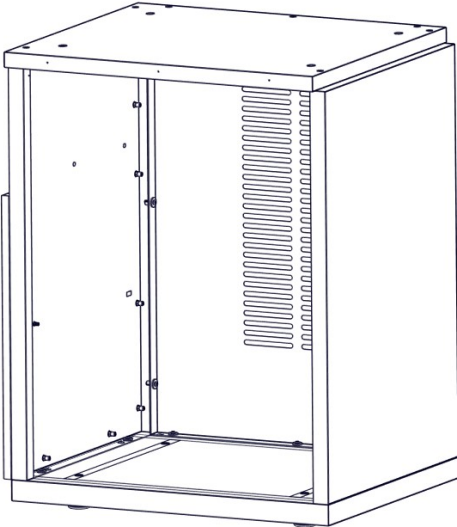

STEP 13 - CABINET ASSEMBLY

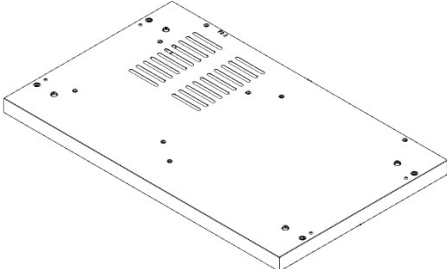

F2 CABINET FLOOR PANEL ASSEMBLY - A4M03048
(x1) 2 5/8"x23 3/8"x38 1/4" (66x594x972)

**- LOOKING AT THE FRONT SIDE OF THE CABINETS,
SLIDE FLOOR PANEL IN BETWEEN SINK AND FRIDGE CABINETS.**

**F2 LABEL INDICATES
BACK OF FLOOR PANEL**

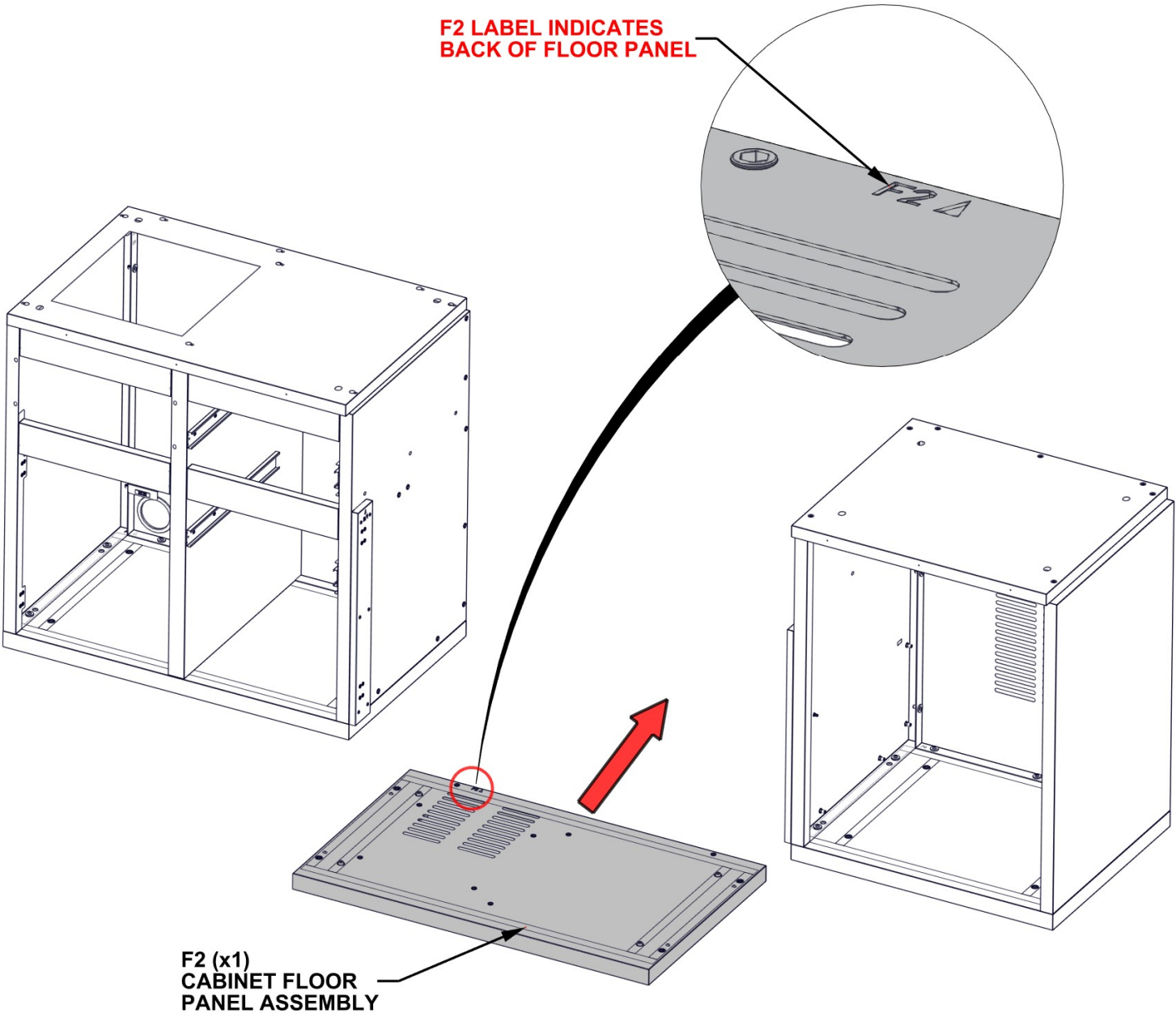

STEP 14 - CABINET ASSEMBLY

- POSITION FLOOR PANEL AS SHOWN BELOW.
- EACH FLOOR PANEL HAS FACTORY INSTALLED ADJUSTABLE FEET. USE PROVIDED HEX DRIVER TO ADJUST EACH FOOT UNTIL PANEL IS LEVEL.

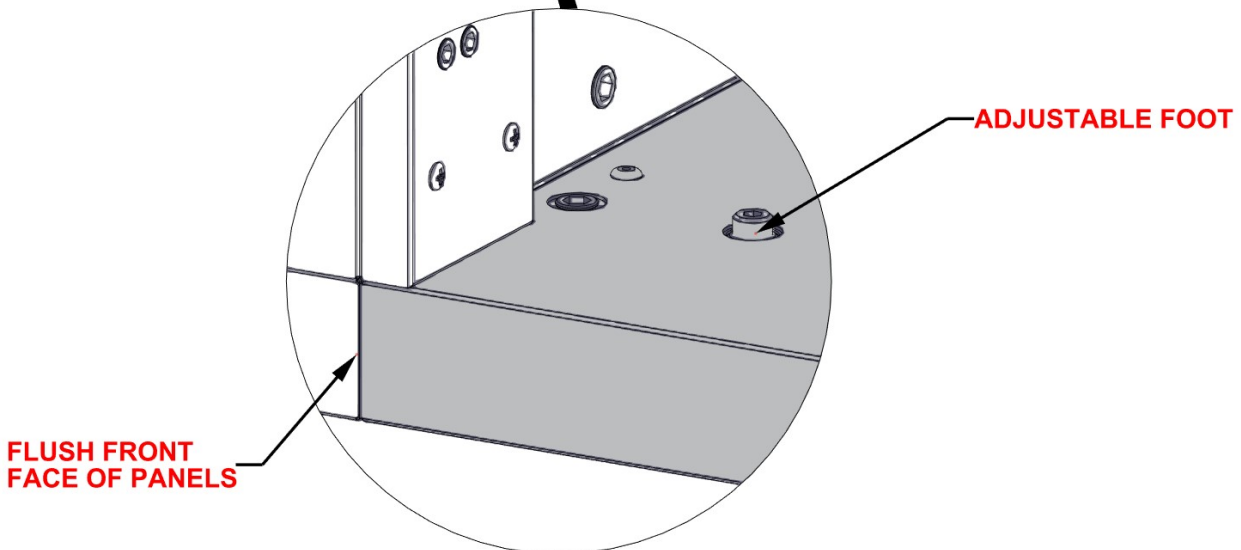
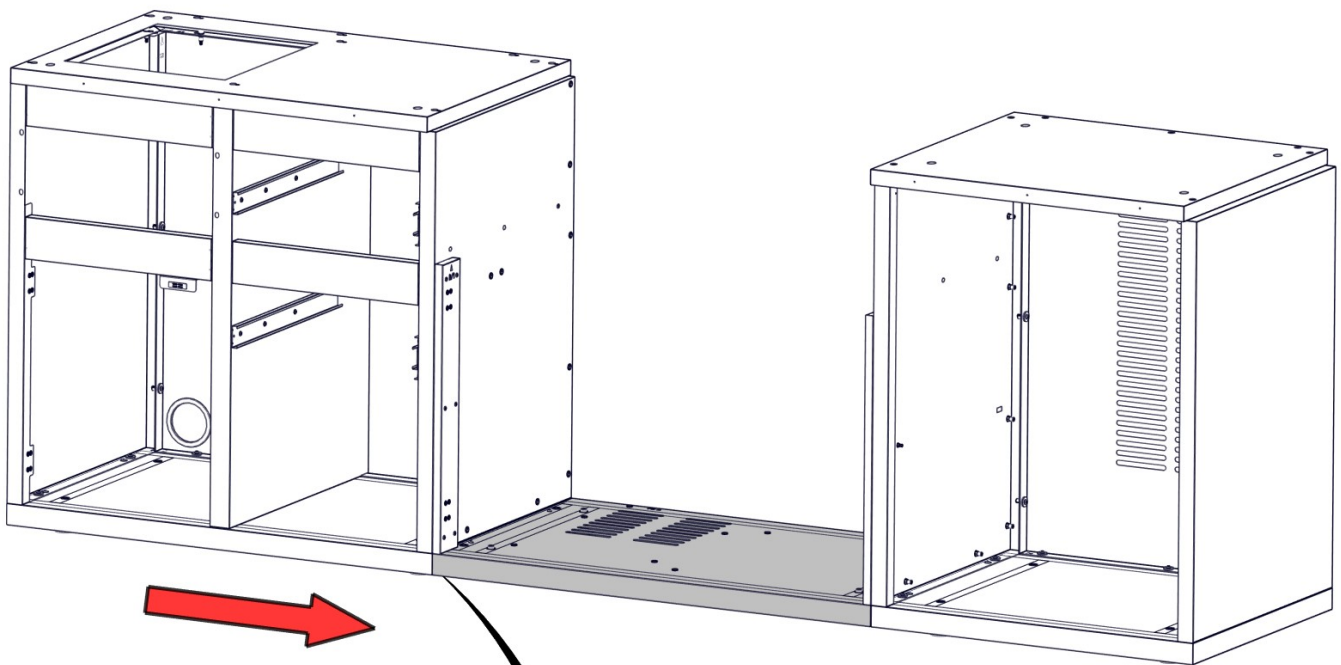

STEP 15 - CABINET ASSEMBLY

Qty	PartNo	Description
4	H101202	TORX PAN HEAD 1/4-20x3/4 ASSY

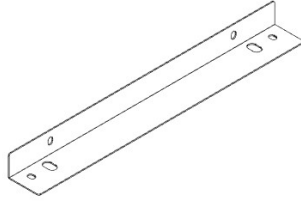

A6 ANGLED BRACKET - A4M03053
(x1) 1 3/8"x1 15/16"x17 1/8" (35x50x435)

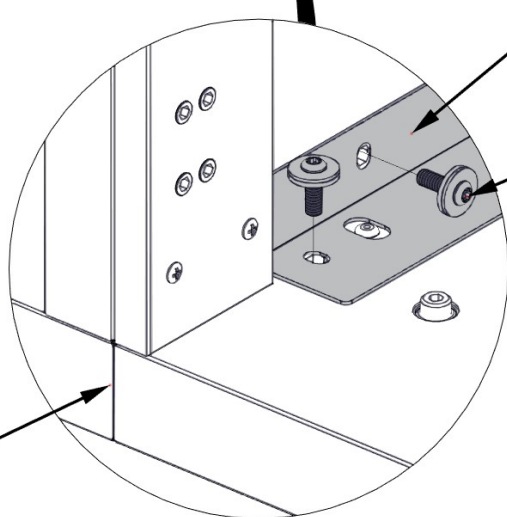
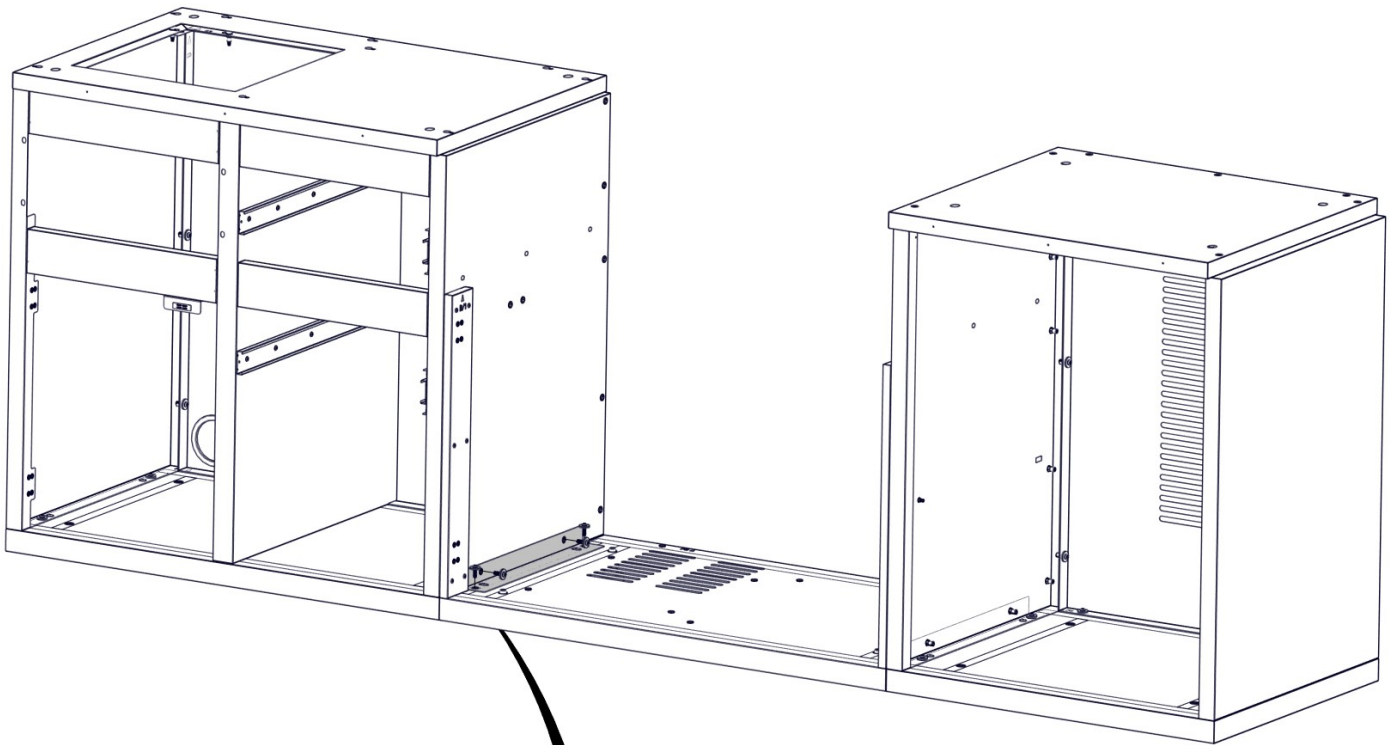

A6 (x1)
ANGLED BRACKET

1202 (x4)
TORX PAN HEAD 1/4-20x3/4 ASSY

**MAKE SURE FRONT
FACE OF FLOOR
PANELS ARE FLUSH**

STEP 16 - CABINET ASSEMBLY

Qty	PartNo	Description
4	H101202	TORX PAN HEAD 1/4-20x3/4 ASSY

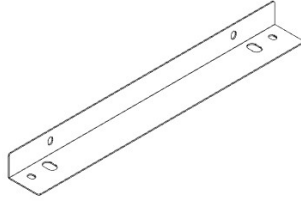

A6 ANGLED BRACKET - A4M03053
(x1) 1 3/8"x1 15/16"x17 1/8" (35x50x435)

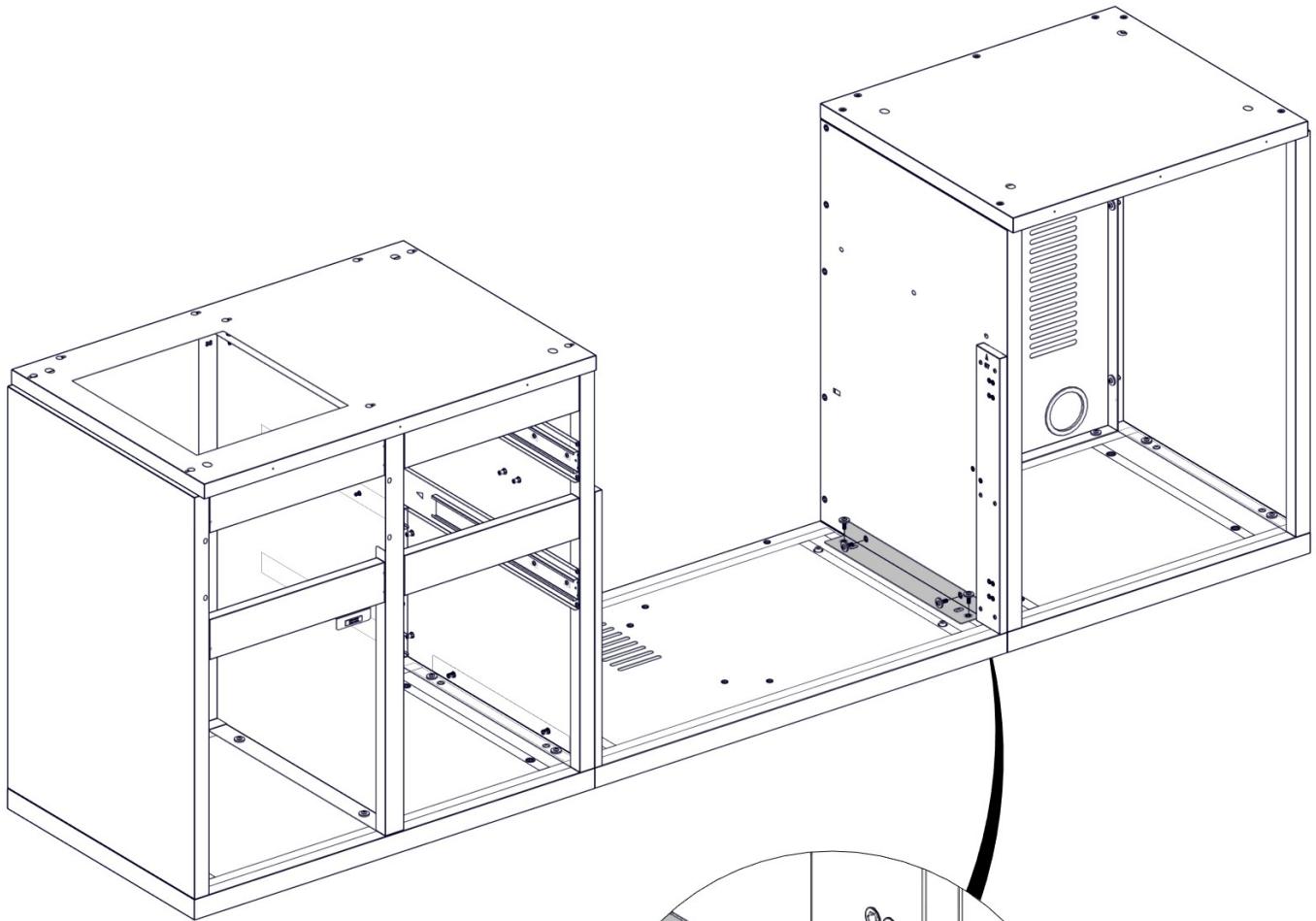

1202 (x4)
TORX PAN HEAD 1/4-20x3/4 ASSY

A6 (x1)
ANGLED BRACKET

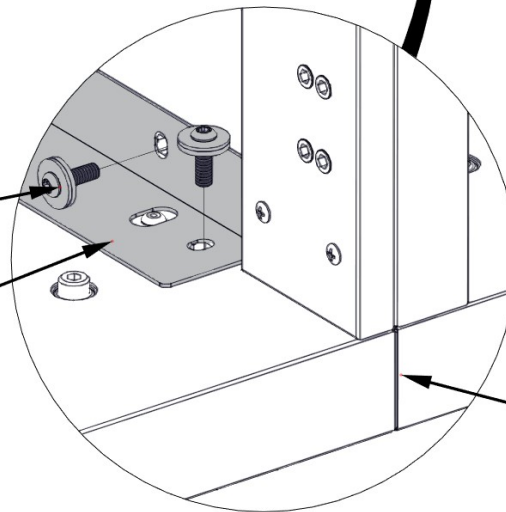

**MAKE SURE FRONT
FACE OF FLOOR
PANELS ARE FLUSH**

STEP 17 - CABINET ASSEMBLY

Qty	PartNo	Description
8	H101202	TORX PAN HEAD 1/4-20x3/4 ASSY

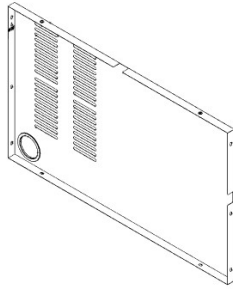

G10 CABINET BACK PANEL ASSEMBLY- A4M03055
(x1) 1 3/16"x22 7/8"x38 3/16" (30x581x970)

**G10 LABEL INDICATES
TOP OF BACK PANEL**

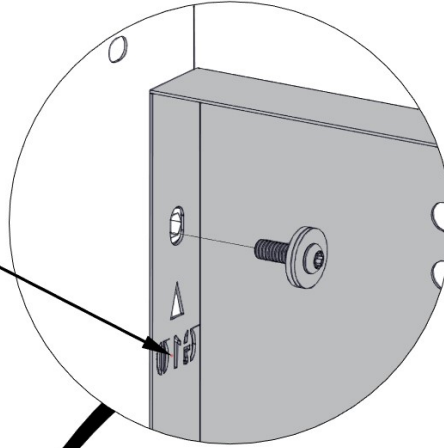

**G10 (x1)
CABINET
BACK PANEL
ASSEMBLY**

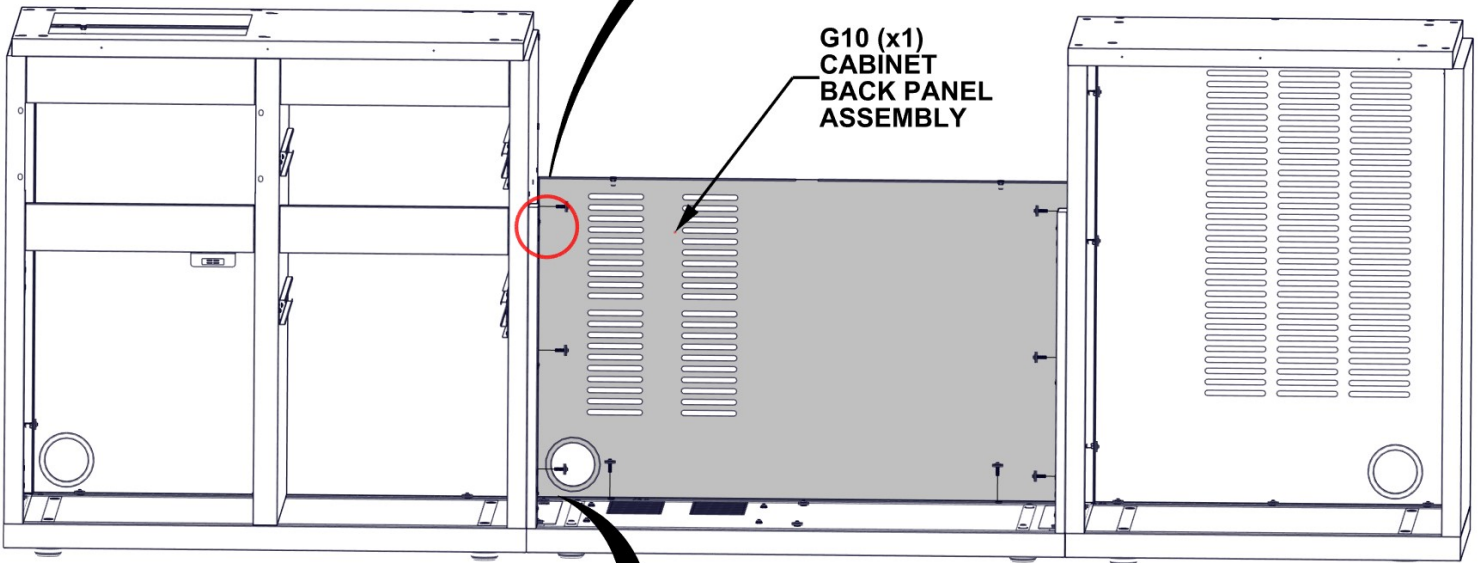

**1202 (x8)
TORX PAN HEAD 1/4-20x3/4 ASSY**

HAND TIGHTEN ONLY

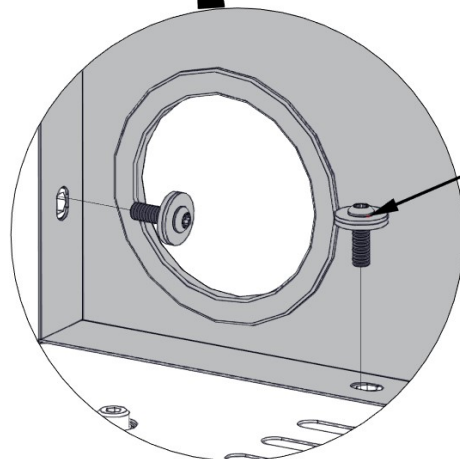

STEP 18 - CABINET ASSEMBLY

Qty	PartNo	Description
2	H101202	TORX PAN HEAD 1/4-20x3/4 ASSY

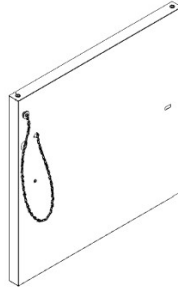

S6 CABINET SIDE PANEL ASSEMBLY M - A4M03586
(x1) 23 3/8"x22 7/8"x1 3/8" (35x581x593)

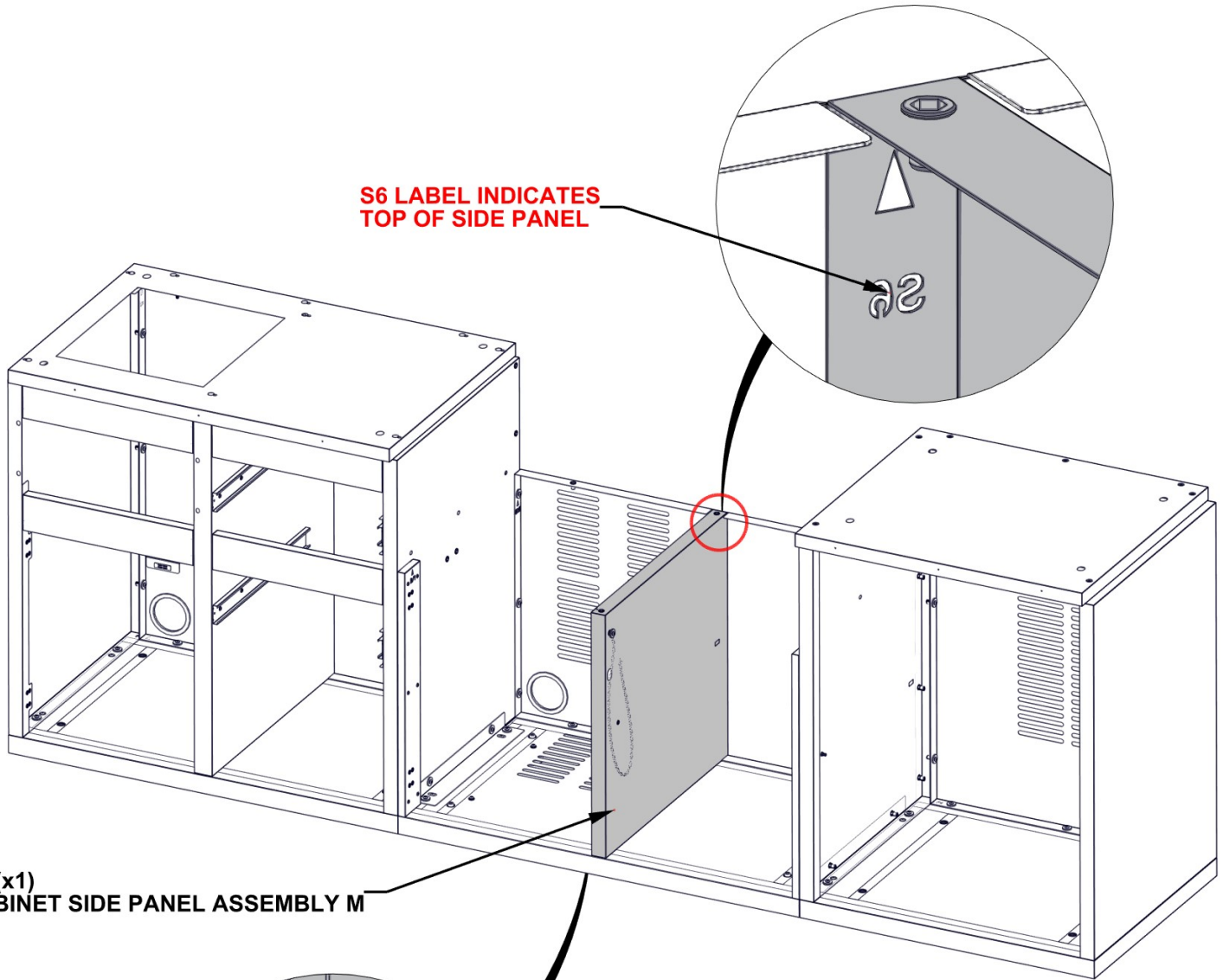

**S6 LABEL INDICATES
TOP OF SIDE PANEL**

**S6 (x1)
CABINET SIDE PANEL ASSEMBLY M**

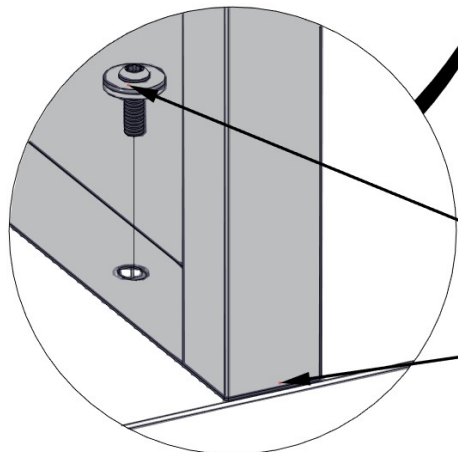

TIGHTEN ALL HARDWARE

**1202 (x2)
TORX PAN HEAD 1/4-20x3/4 ASSY**

**FLUSH FRONT FACE
OF SIDE PANEL WITH
FLOOR PANEL**

STEP 19A - CABINET ASSEMBLY

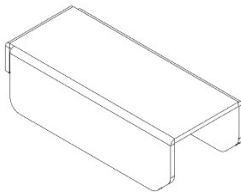

A5 SHELF BRACKET - A4M03141
(x2) 5/8"x7/8"x2 1/16" (16x22x53)

- BRACKETS WILL BE TOWARD THE BACK OF THE CABINET.
- ATTACH SHELF BRACKETS ON BOTH SIDES OF CENTER CABINET.

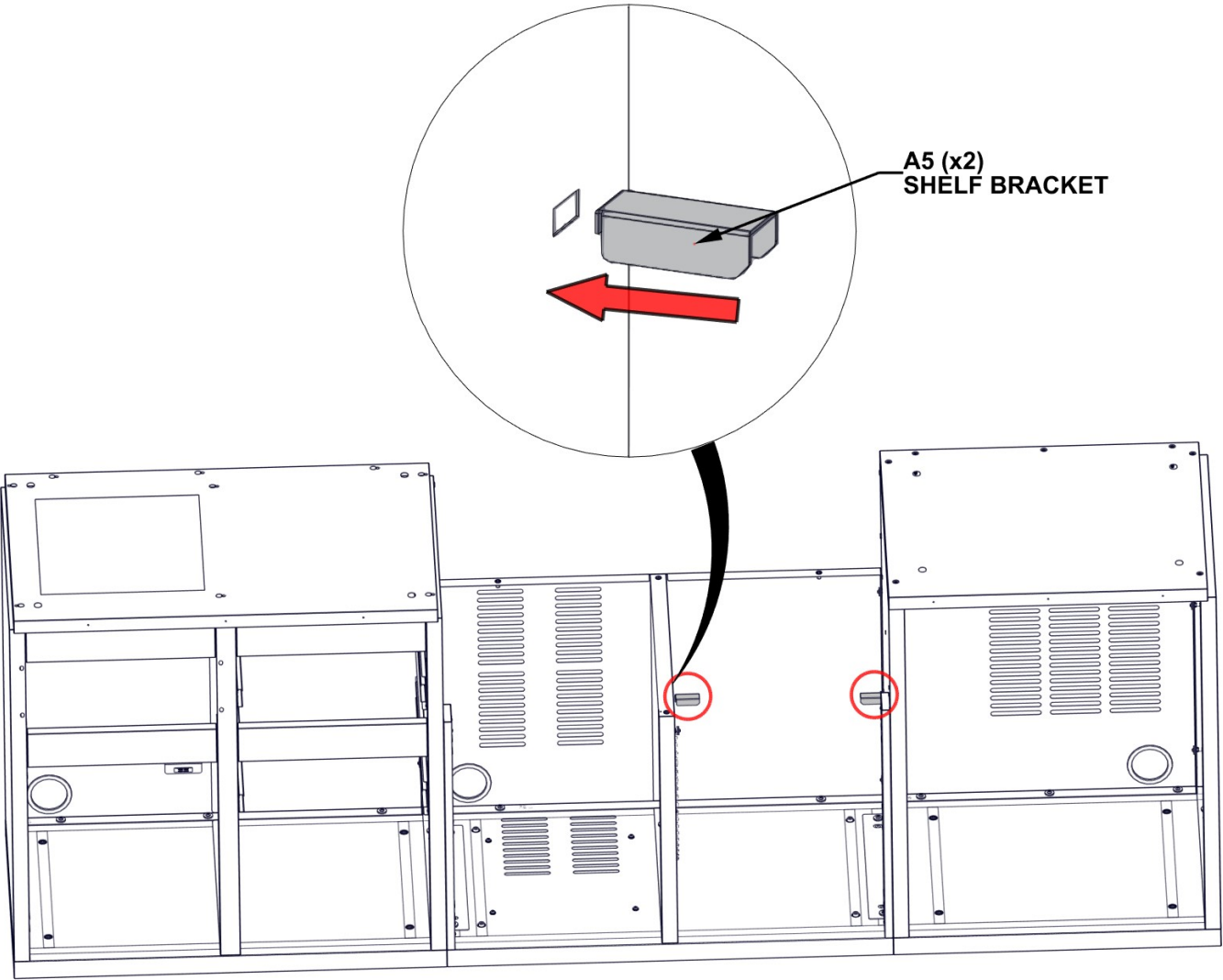

STEP 19B - CABINET ASSEMBLY

Qty	PartNo	Description
3	H101289	PAN HEAD SCREW 8-32x1/2" SS

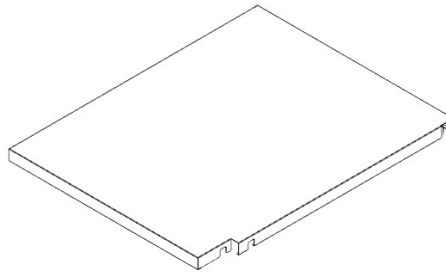

L2 CABINET SHELF ASSEMBLY - A4M03589
(x1) 23 1/4"x18 3/8"x1" (25.00x467.00x591.00)

- ALIGN SHELF WITH THREADED INSERTS AND ATTACH HARDWARE TO FASTEN IN PLACE.

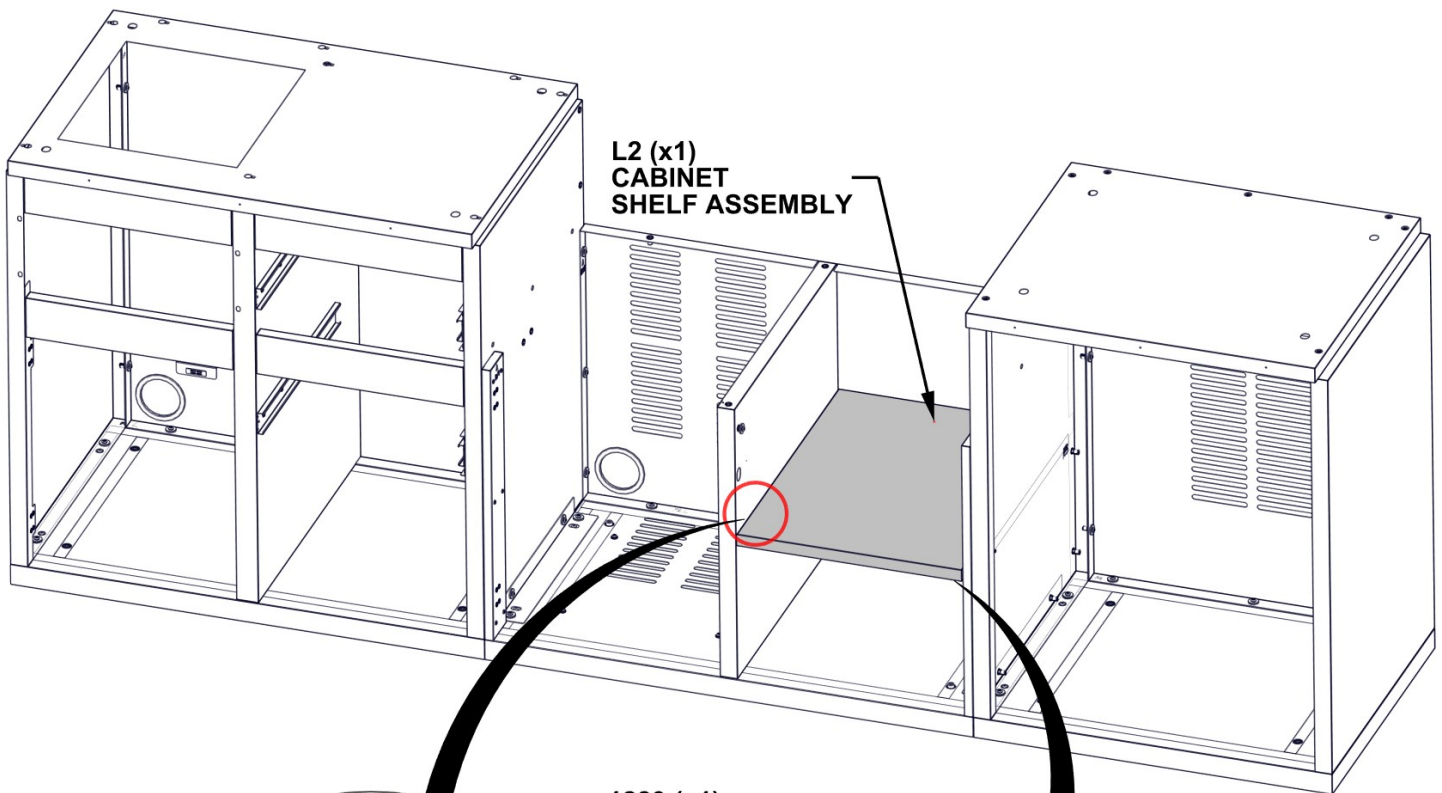

L2 (x1)
CABINET
SHELF
ASSEMBLY

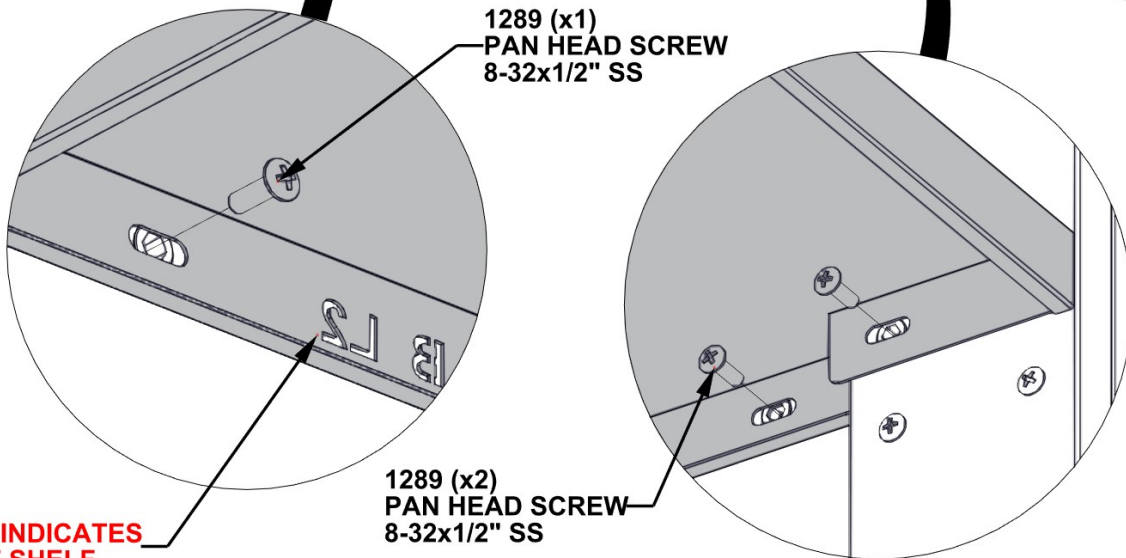

1289 (x1)
PAN HEAD SCREW
8-32x1/2" SS

1289 (x2)
PAN HEAD SCREW
8-32x1/2" SS

L2 LABEL INDICATES
FRONT OF SHELF

STEP 20 - CABINET ASSEMBLY

Qty	PartNo	Description
2	H101202	TORX PAN HEAD 1/4-20x3/4 ASSY

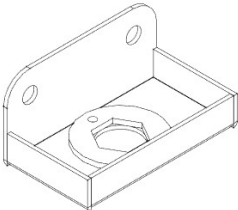

A9 HOSE BRACKET ASSEMBLY - A4M03060
(x1) 1 1/4"x1 7/16"x2 9/16" (31.5x36.5x65)

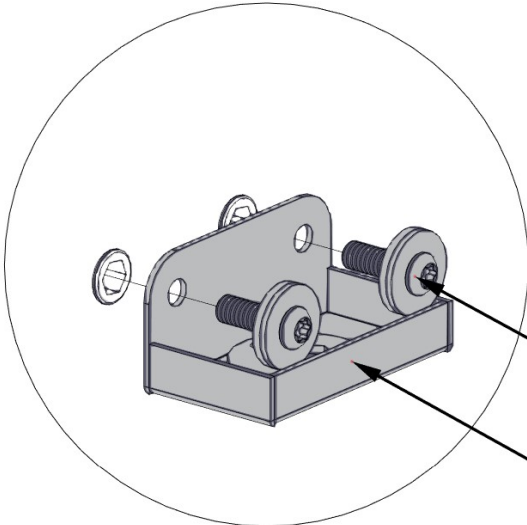

1202 (x2)
TORX PAN HEAD 1/4-20x3/4 ASSY

A9 (x1)
HOSE BRACKET ASSEMBLY

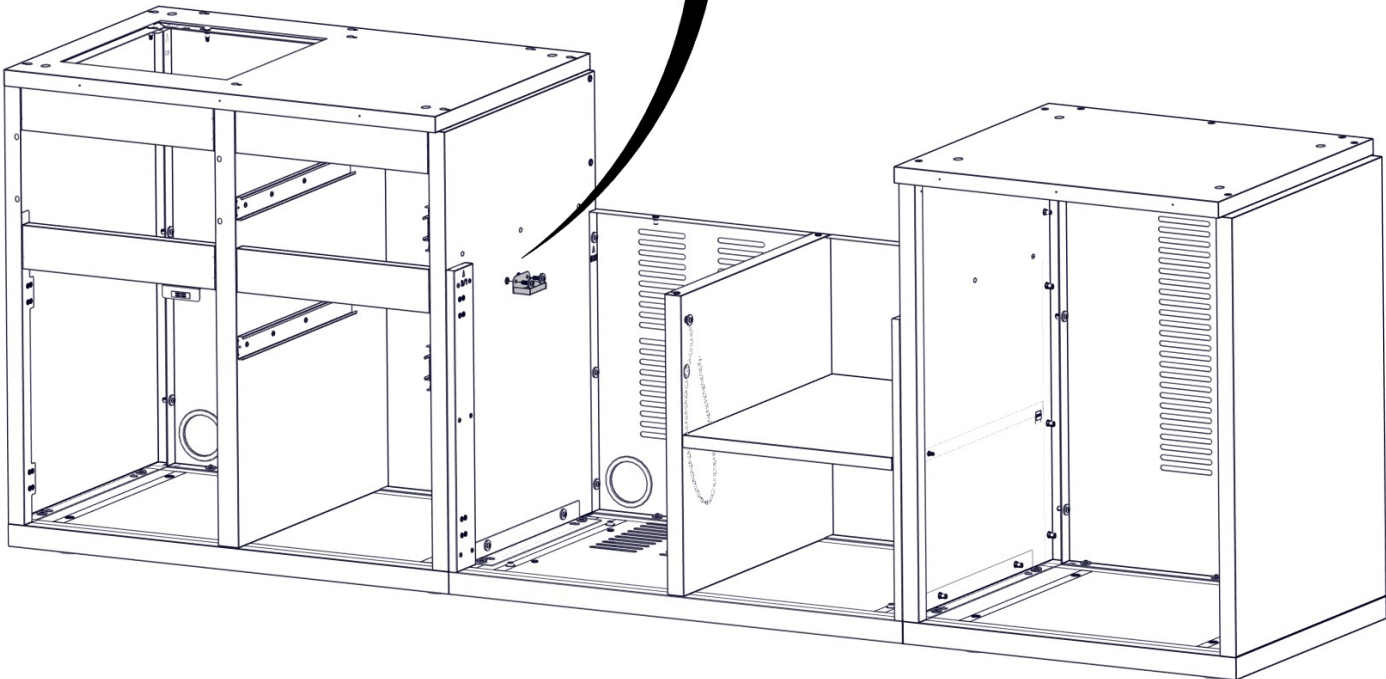

STEP 21 - CABINET ASSEMBLY

Qty	PartNo	Description
4	H101292	TORX PAN HEAD 1/4-20x13/32"

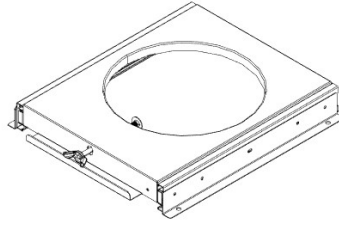

A13 GAS TANK HOLDER ASSEMBLY - A4M03047
(x1) 1 15/16"x12 7/8"x14 3/4" (49x327x374)

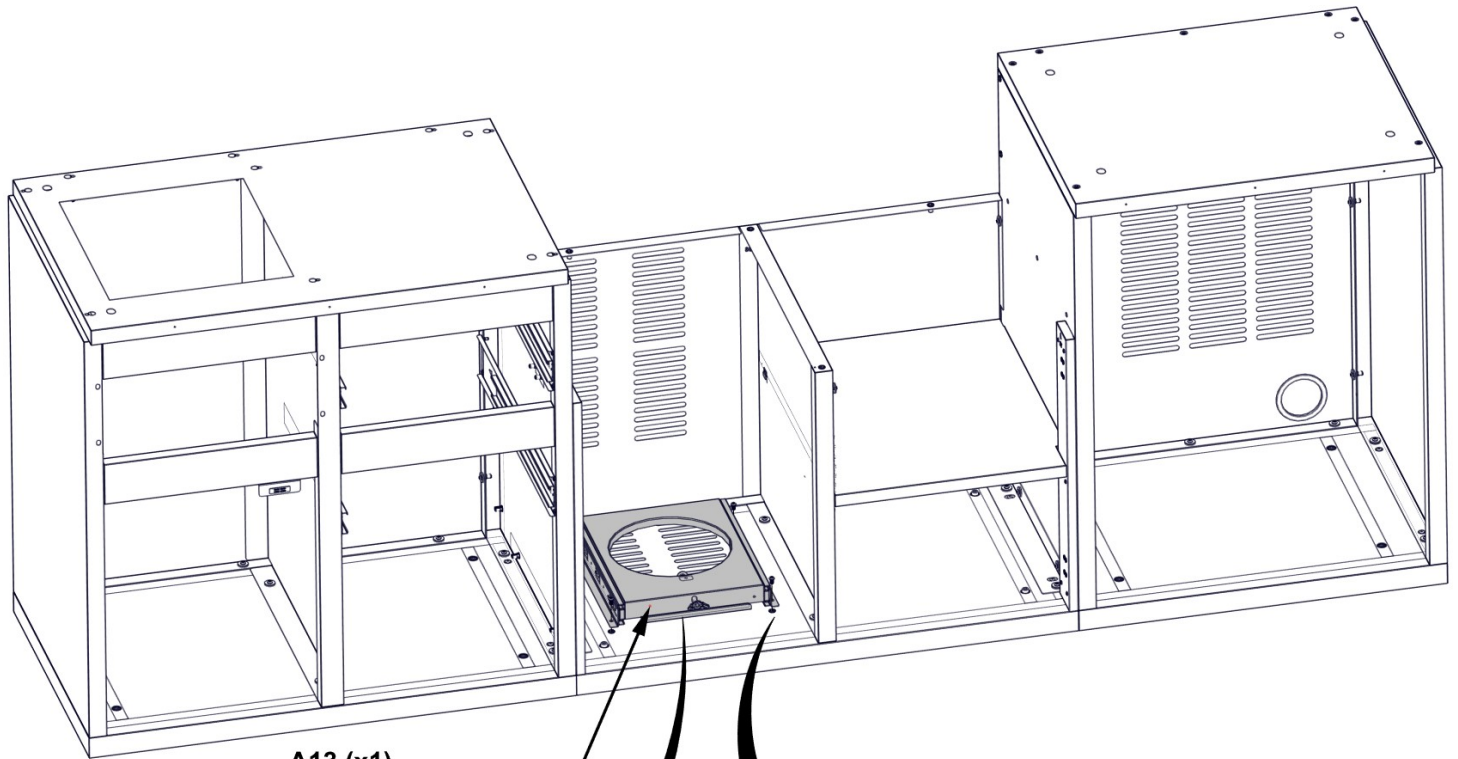

A13 (x1)
GAS TANK HOLDER
ASSEMBLY

1292 (x4)
TORX PAN HEAD 1/4-20x13/32"

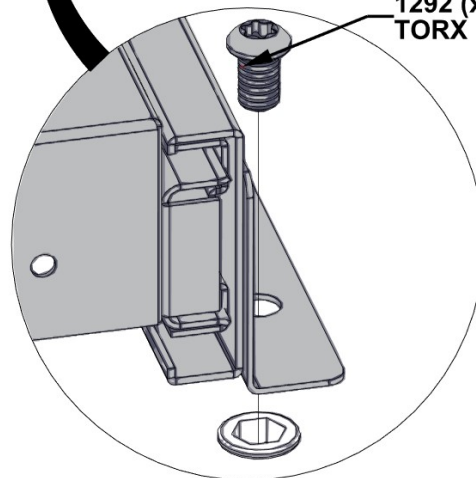
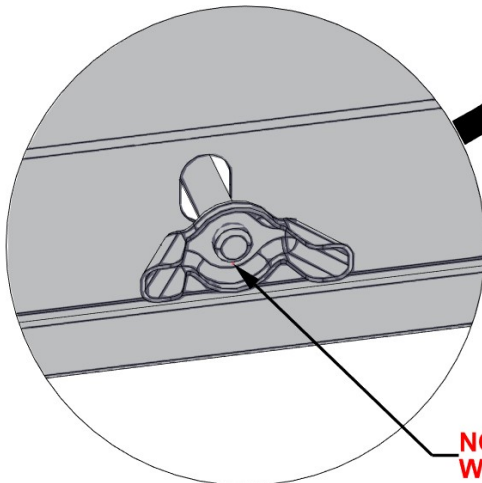

NOTE ORIENTATION OF
WING NUT TOWARDS FRONT

STEP 22 - CABINET ASSEMBLY

Qty	PartNo	Description
4	H101289	PAN HEAD SCREW 8-32x1/2" SS

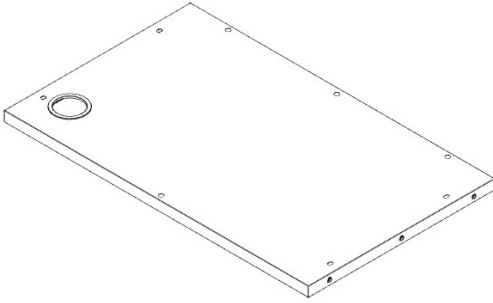

T2 TABLETOP ASSEMBLY - A4M03057
 (x1) 1 1/4"x23 3/8"x38 3/16" (32x594x970)

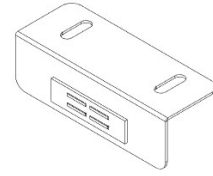

A2 MAGNET BRACKET - A4M03026
 (x2) 1"x1 1/4"x3 1/8" (25x31x80)

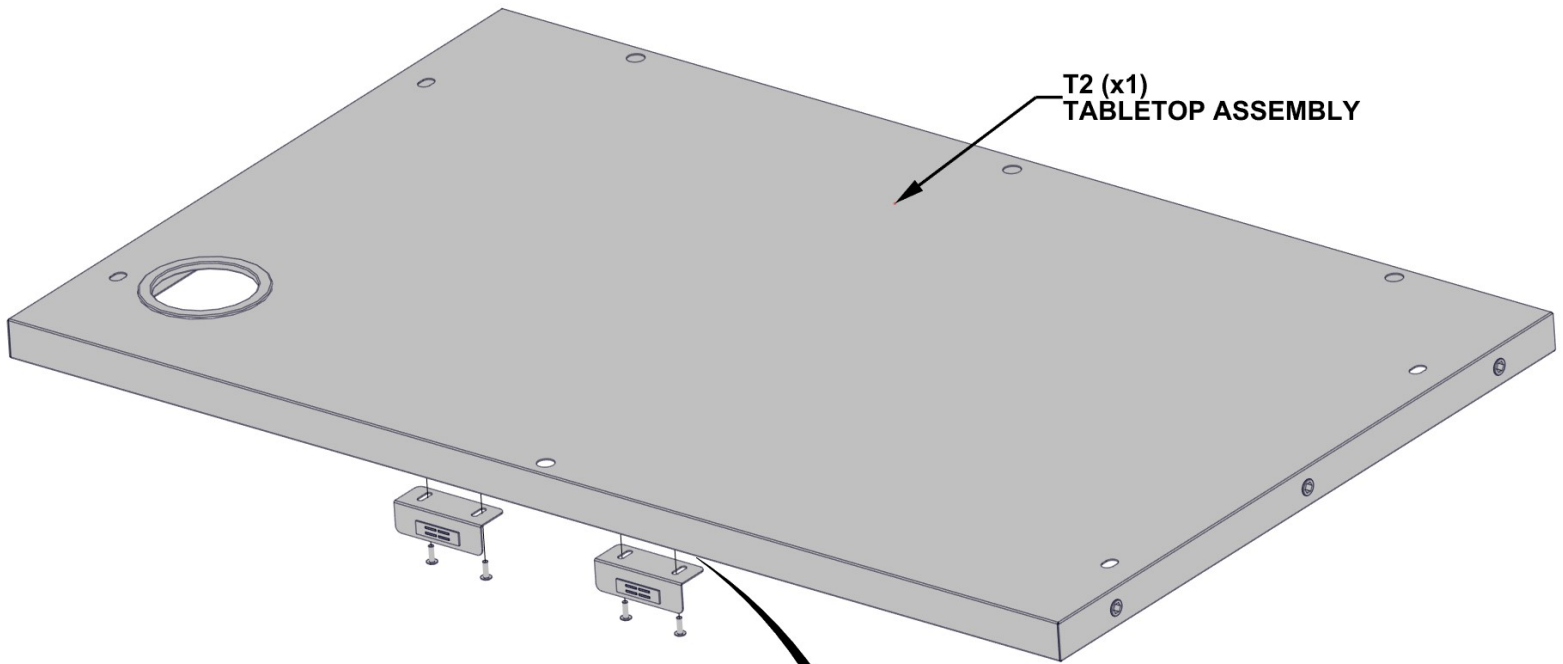

T2 (x1)
TABLETOP ASSEMBLY

A2 (x2)
MAGNET BRACKET

1289 (x4)
PAN HEAD SCREW 8-32x1/2" SS

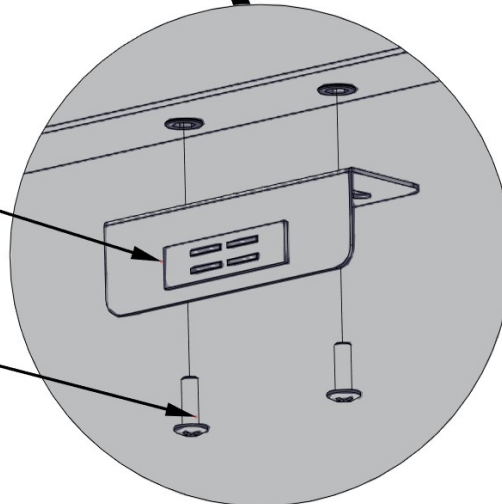

STEP 23A - CABINET ASSEMBLY

Qty	PartNo	Description
6	H101202	TORX PAN HEAD 1/4-20x3/4 ASSY

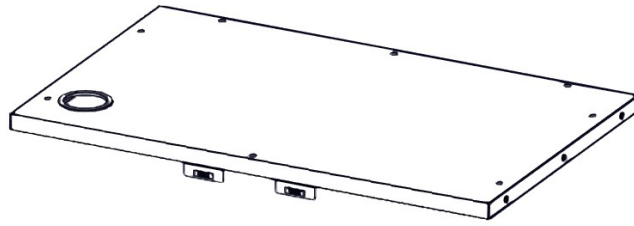

TABLETOP
ASSEMBLY FROM STEP 22

- HARDWARE ATTACHES ON INSIDE OF ADJACENT CABINET.

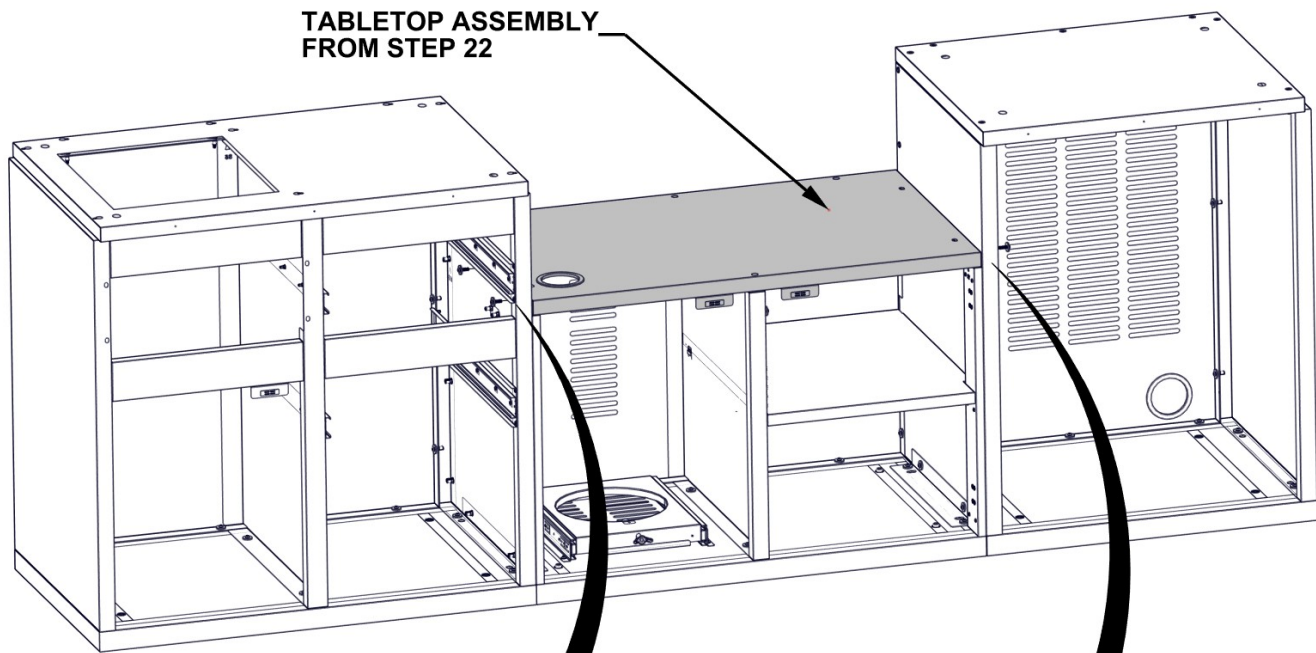

TABLETOP ASSEMBLY
FROM STEP 22

HAND TIGHTEN ONLY

1202 (x3)
TORX PAN HEAD
1/4-20x3/4 ASSY

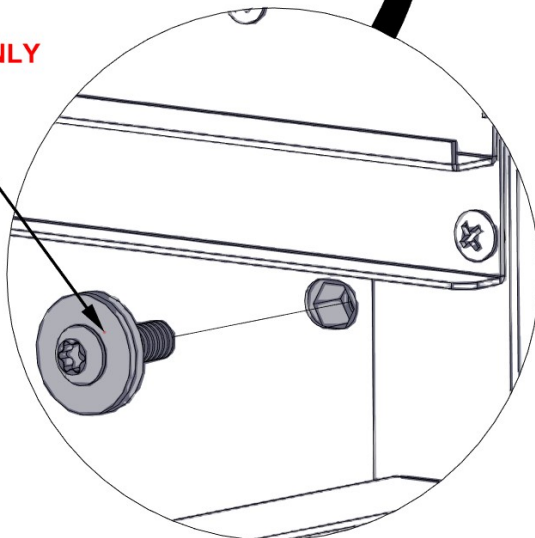

HAND TIGHTEN ONLY

1202 (x3)
TORX PAN HEAD
1/4-20x3/4 ASSY

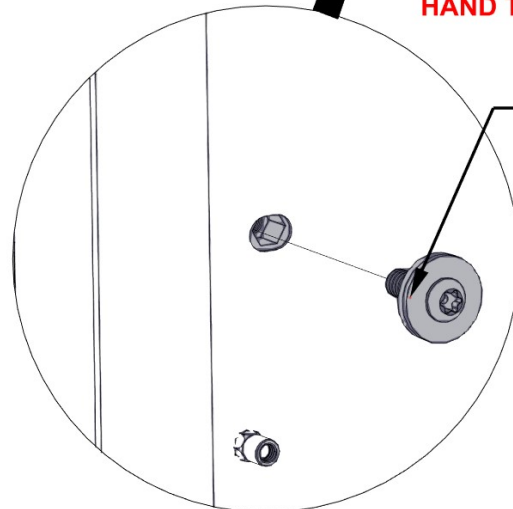

STEP 23B - CABINET ASSEMBLY

Qty	PartNo	Description
4	H101103	TORX SOCKET SCREW 1/4-20

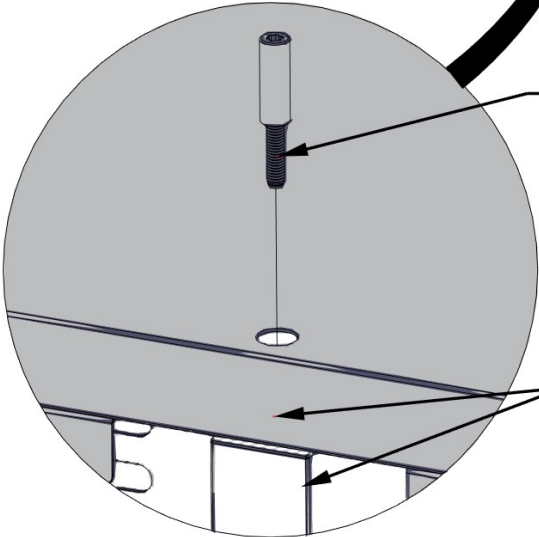
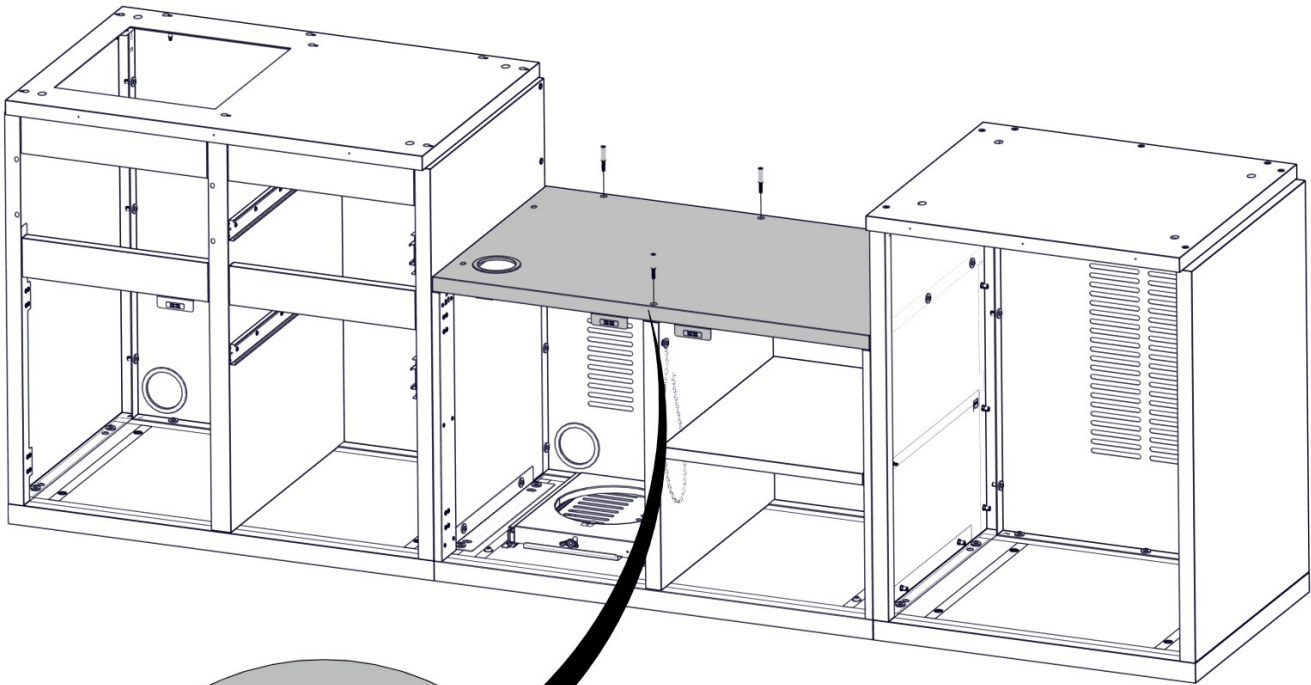

1103 (x4)
TORX SOCKET SCREW 1/4-20

TIGHTEN ALL HARDWARE

**MAKE SURE FRONT
FACE OF TABLETOP
IS FLUSH WITH
UPRIGHT PANEL**

STEP 24 - CABINET ASSEMBLY

Qty	PartNo	Description
4	H101202	TORX PAN HEAD 1/4-20x3/4 ASSY

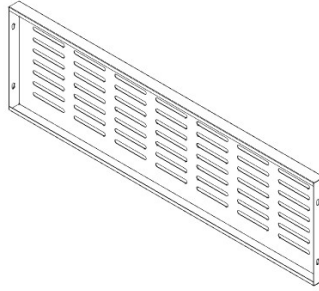

G11 VENTILATION PANEL - A4M03056
(x1) 1 5/16"x11 3/16"x38 3/16" (33x284x970)

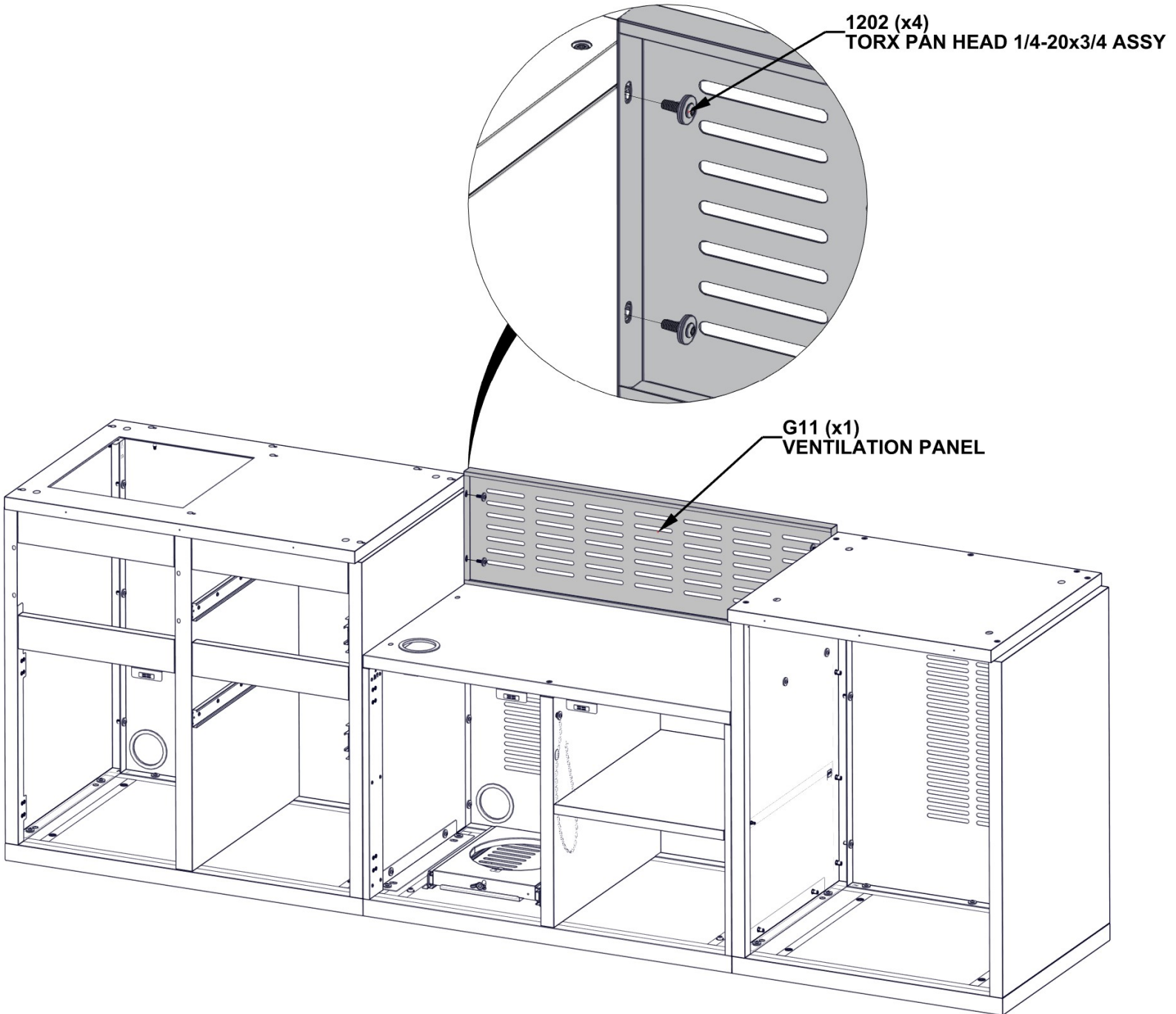

STEP 25 - SINK CABINET FALSE PANEL ASSEMBLY

Qty	PartNo	Description
2	H101289	PAN HEAD SCREW 8-32x1/2" SS

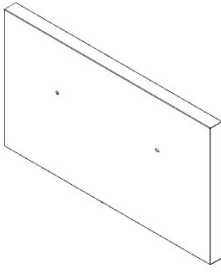

D5 SINK CABINET TRIM PANEL - A4M03576
 (x1) 17 13/16"x10 1/4"x1" (26x260x452)

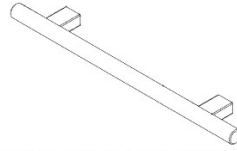

H2 STAINLESS STEEL HANDLE - A4M03024
 (x1) 5/8"x1 9/16"x11 13/16" (16x40x300)

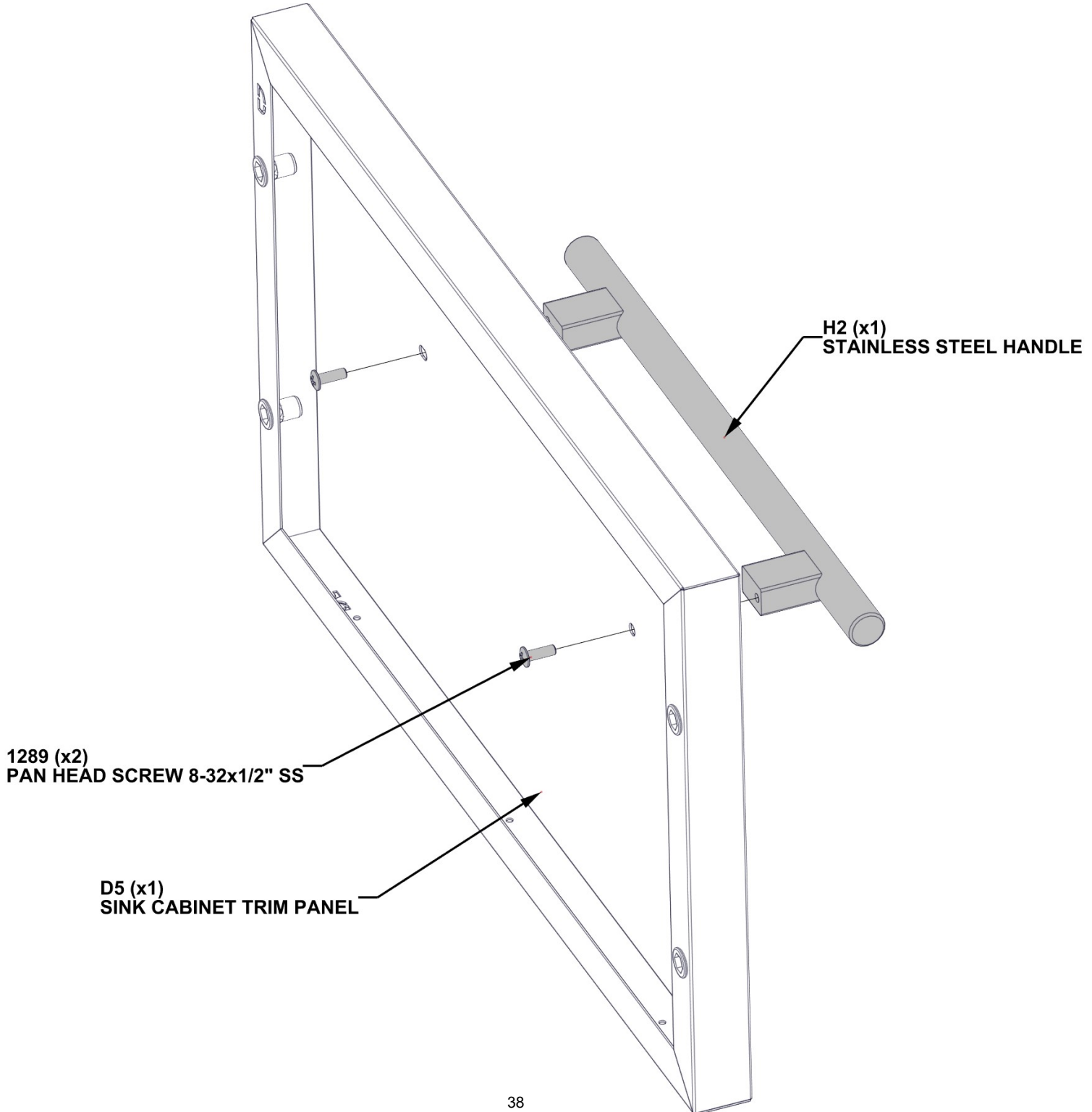

STEP 26 - SINK CABINET FALSE PANEL ATTACHMENT

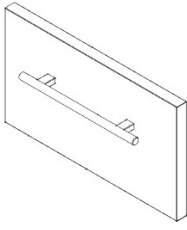

FALSE PANEL ASSEMBLY
FROM STEP 25

Qty	PartNo	Description
4	H101202	TORX PAN HEAD 1/4-20x3/4 ASSY

- HARDWARE ATTACHES ON INSIDE OF CABINET.

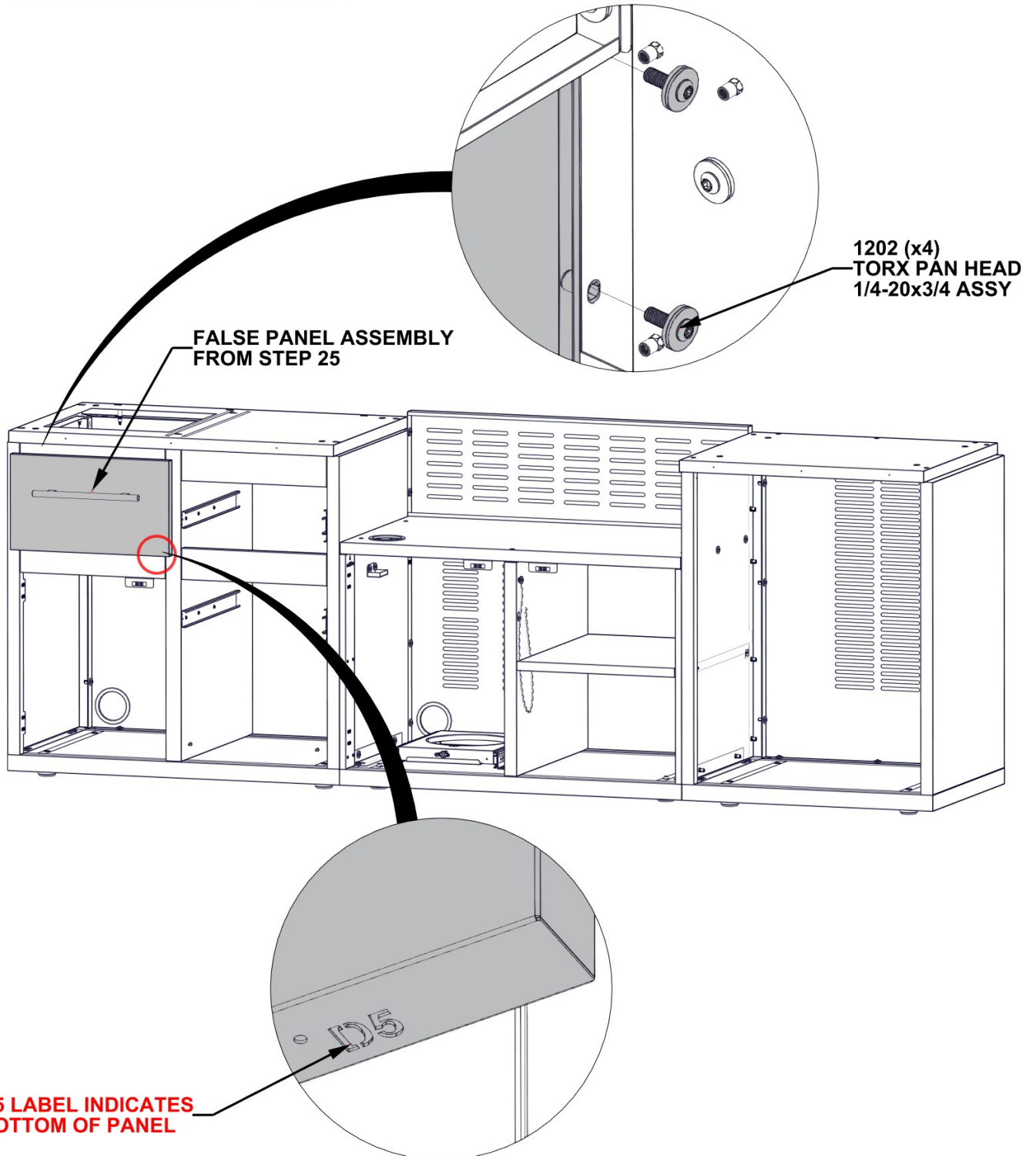

STEP 27A - SINK PRE-ASSEMBLY

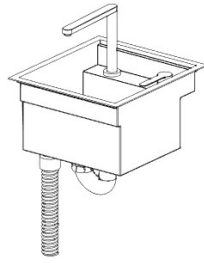

A16 SINK ASSEMBLY - A4M03143
(x1) 15 1/8"x15 5/16"x16 7/8" (384x389x429)

1. INSTALLING THE SINK DRAIN

- SET DRAIN INSIDE OF SINK BODY, PLACING FOAM GASKET BETWEEN SURFACES.
- FASTEN IN PLACE USING RUBBER GASKET AND DRAIN NUT FROM BOTTOM SIDE.

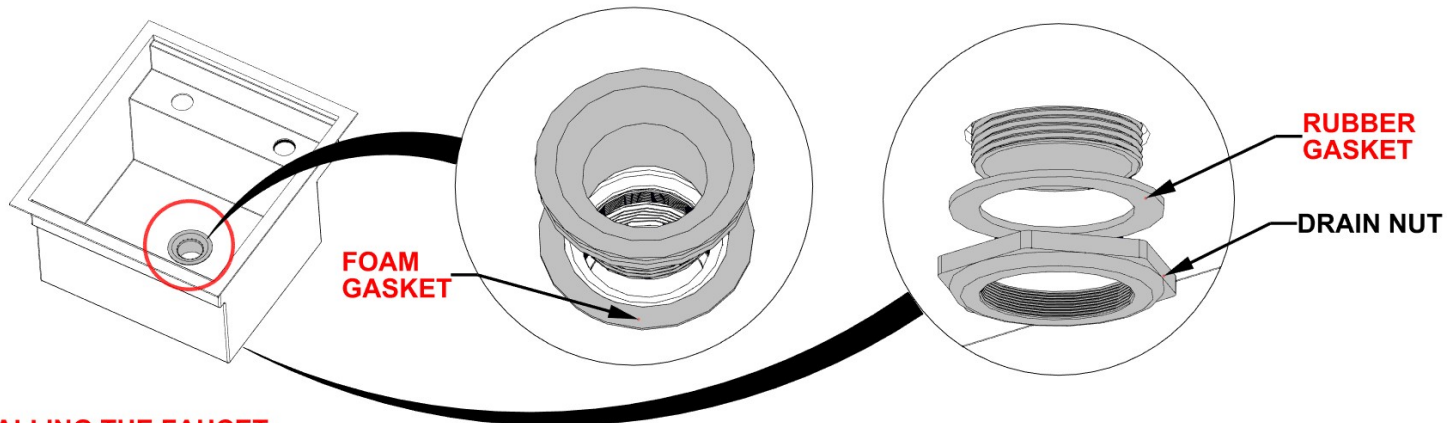

2. INSTALLING THE FAUCET

- INSTALL FAUCET BY PLACING HANDLE AND SPOUT INTO SINK OPENINGS AND SECURING IN PLACE VIA NUT.
- INSERT SCREWS TO LOCK.
- CONNECT WATER FAUCET LINES TOGETHER.

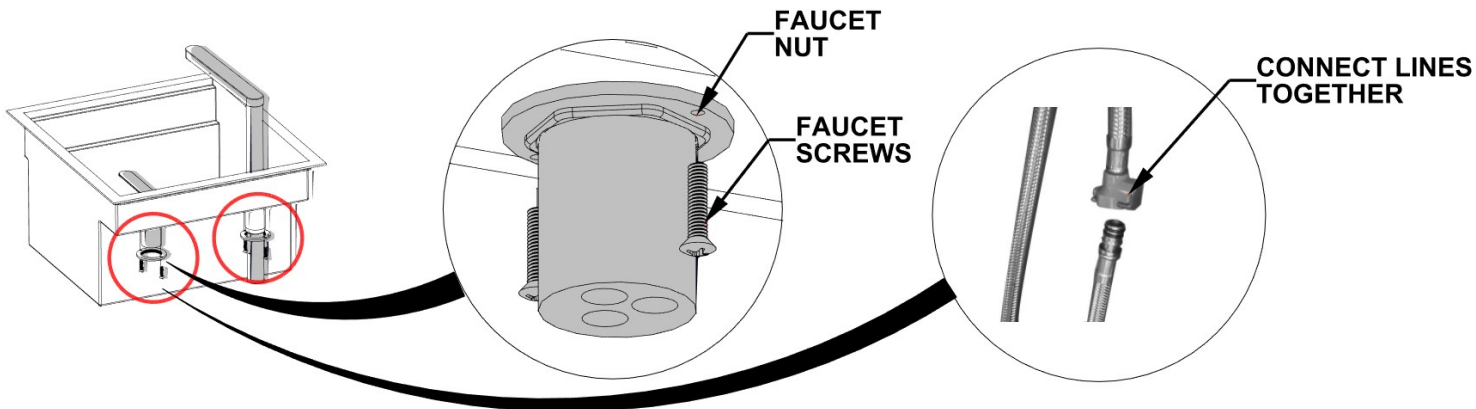

3. INSTALLING THE DRAIN FITTING

- ATTACH DRAIN FITTING TO SINK DRAIN.

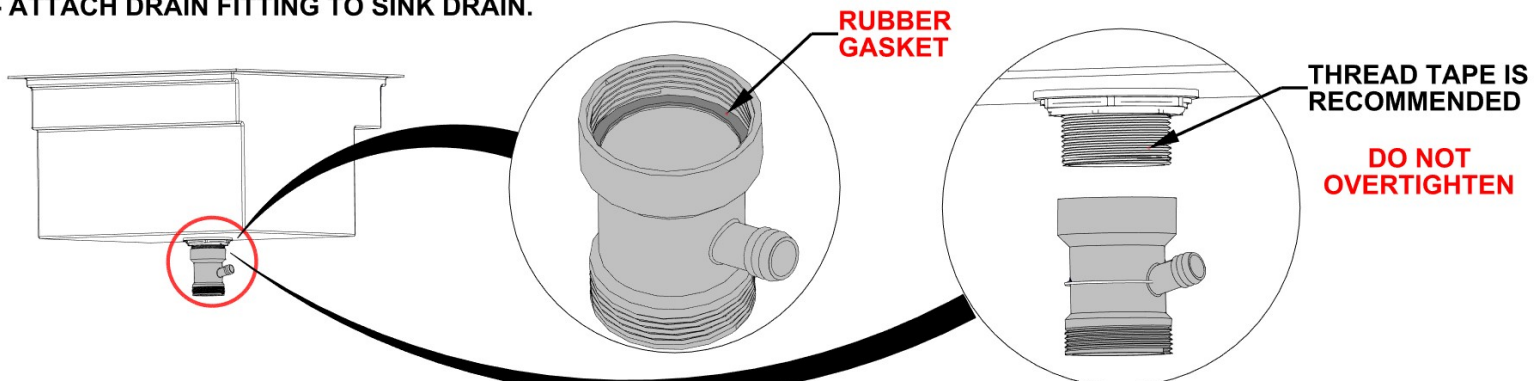

STEP 27B - SINK PRE-ASSEMBLY

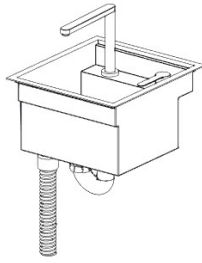

A16 SINK ASSEMBLY - A4M03143
(x1) 15 1/8"x15 5/16"x16 7/8" (384x389x429)

4. INSTALLING THE OVERFLOW DRAIN

- MAKE SURE RUBBER GASKET IS INSTALLED IN OVERFLOW DRAIN.
- INSERT DRAIN SCREW TO HOLD IN PLACE.

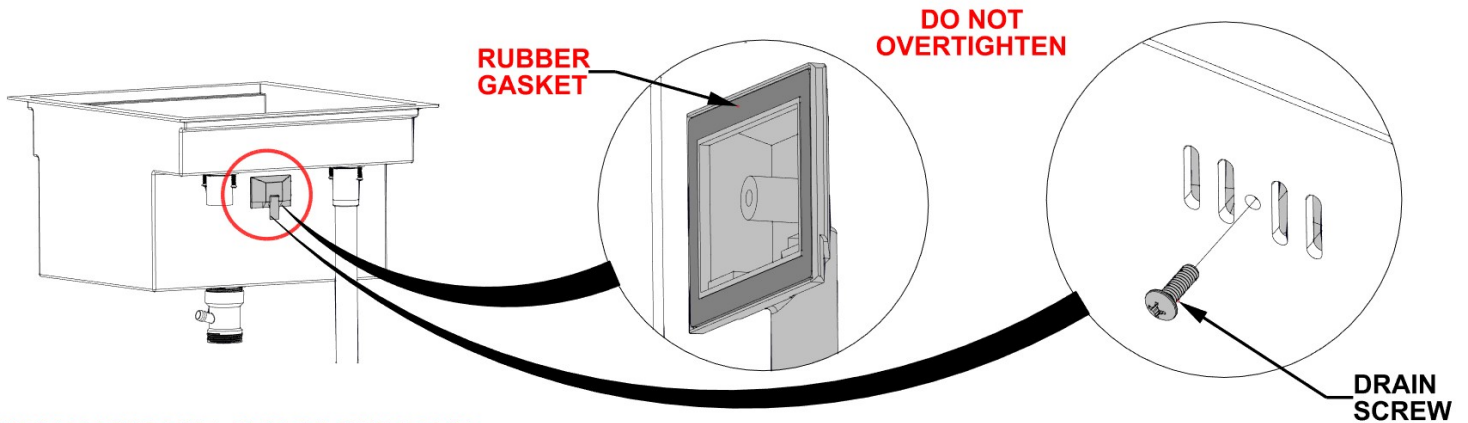

5. INSTALLING THE OVERFLOW DRAIN

- ATTACH OVERFLOW DRAIN BY CONNECTING EACH END AS SHOWN.

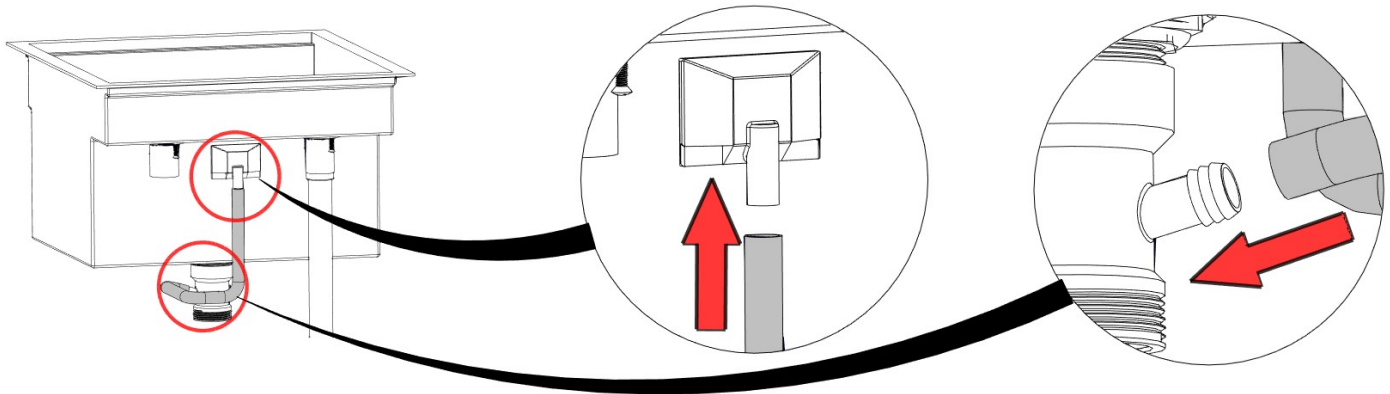

6. INSTALLING THE MAIN DRAIN AND TRAP

- ATTACH TRAP AND CORRUGATED DRAIN HOSE TO DRAIN FITTING.

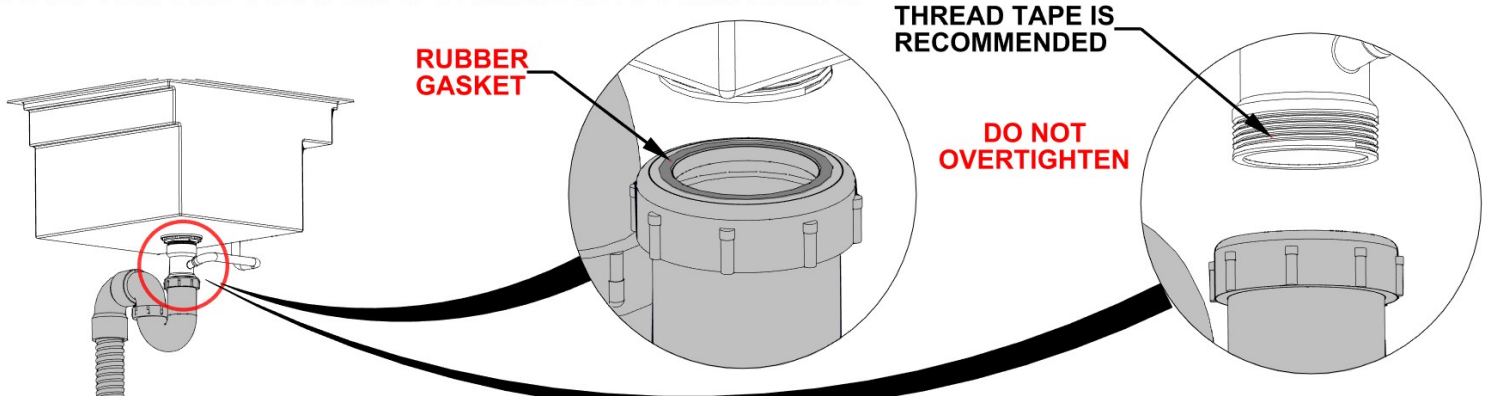

STEP 27C - SINK INSTALLATION

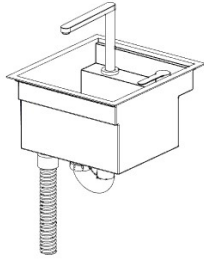

A16 SINK ASSEMBLY - A4M03143
(x1) 15 1/8"x15 5/16"x16 7/8" (384x389x429)



A4M03151 GARDEN HOSE ADAPTER
(x1)

- DRAIN STRAINER MUST BE USED WHEN DISCARDING FOOD INSIDE OF SINK.
- DO NOT LET SOLID MATERIAL ENTER SINK BASIN.

OPTIONS FOR WATER INLET SUPPLY HOOKUP:

- GARDEN HOSE ATTACHMENT USING PROVIDED ADAPTER
- WATER INLET SUPPLY LINE

ATTACH ADAPTER TO INLET LINE AND TIGHTEN WITH WRENCH

OPTIONS FOR DRAIN DISCHARGE:

- BUCKET OR GREY WATER CONTAINER
- FRENCH DRAIN OR DRY BASIN
- INTEGRATED SEWER SYSTEM
- CHECK YOUR LOCAL REQUIREMENTS.

3151 (x1)
GARDEN HOSE
ADAPTER

IT IS RECOMMENDED TO APPLY A FINE BEAD OF SILICONE, TO UNDERNEATH SIDE OF ALL SINK FLANGES BEFORE INSTALLING

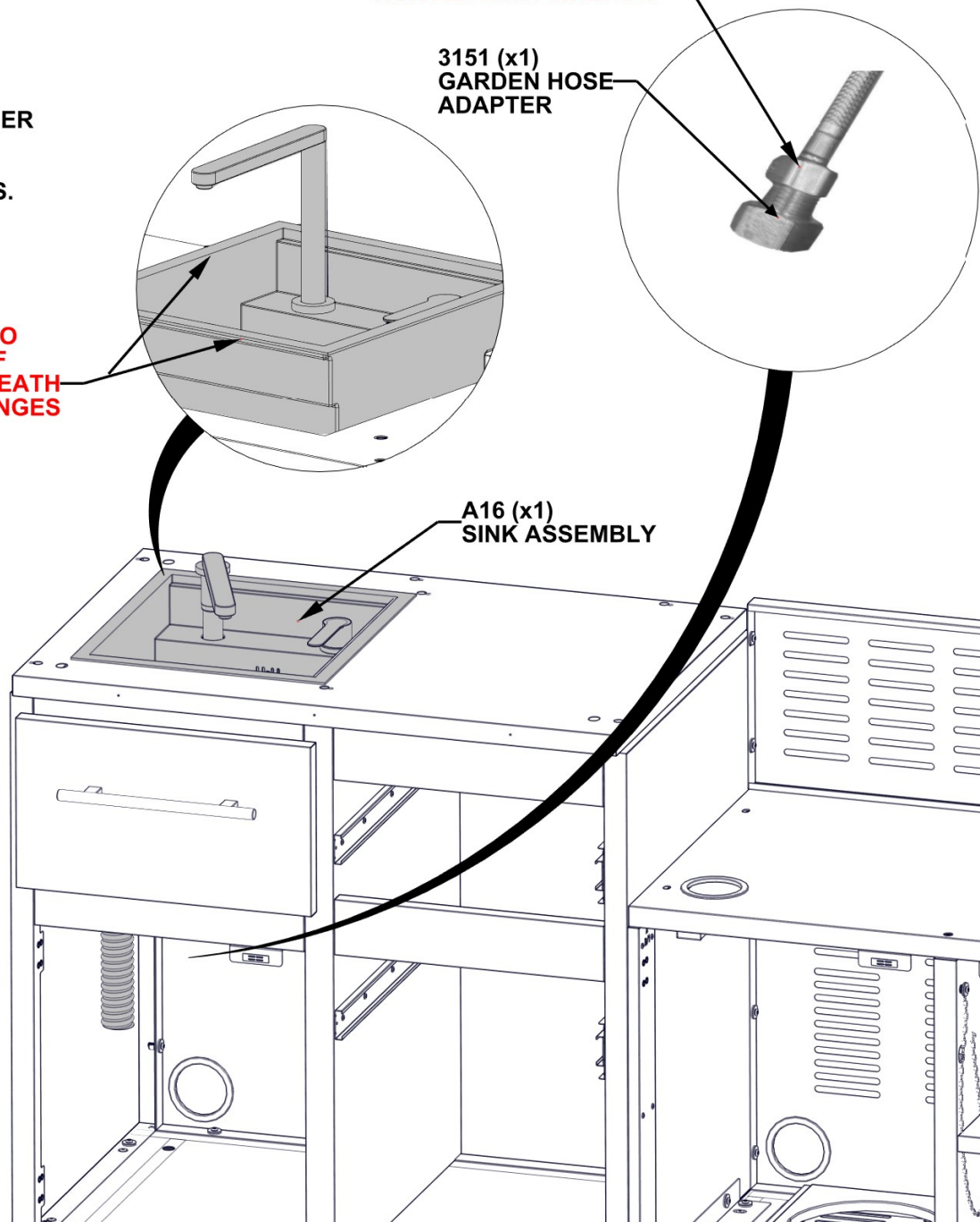

STEP 28A - FRIDGE CABINET COUNTERTOP INSTALLATION

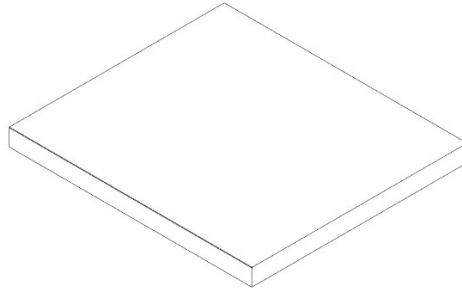

M3 COUNTERTOP - A4M06163
(x1) 28 1/8"x24 15/16"x1 15/16" (50x634x715)

- IT IS RECOMMENDED TO HAVE AT LEAST TWO PEOPLE SET COUNTERTOP IN PLACE.
- SLIDE IN PLACE UNTIL COUNTERTOP IS TIGHT AGAINST CABINET AND SIDES ARE FLUSH WITH PANEL.
- **WHEN SETTING COUNTERTOP IN PLACE, MAKE SURE YOUR FINGERS ARE CLEAR AND NOT UNDERNEATH.**

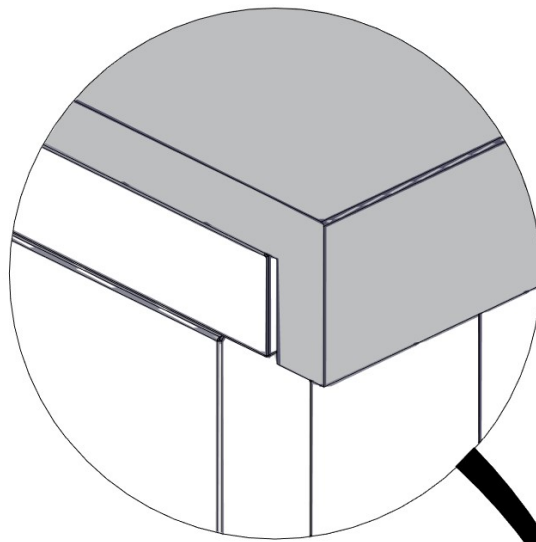

M3 (x1)
COUNTERTOP

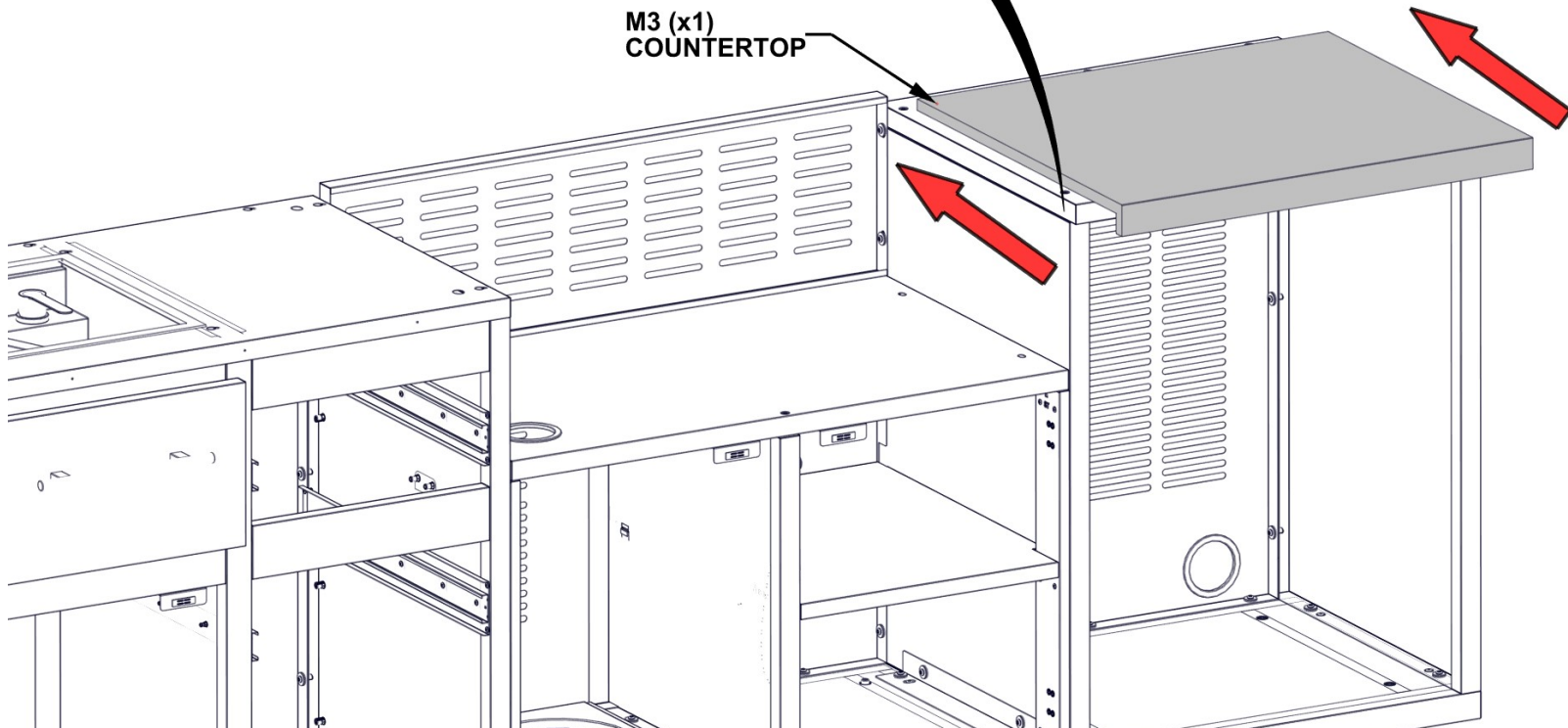

STEP 28B - FRIDGE CABINET COUNTERTOP INSTALLATION

Qty	PartNo	Description
4	H101292	TORX PAN HEAD 1/4-20x13/32"
4	H101053	STEEL WASHER 6x20
4	H101054	SEALANT WASHER

- MAKE SURE YOU ARE USING THE CORRECT HARDWARE FOR THIS STEP.
- ONCE COUNTERTOP IS IN PLACE, IT IS RECOMMENDED TO COVER WITH A PIECE OF CARDBOARD OR FOAM UNTIL ASSEMBLY IS FINISHED TO PREVENT DAMAGE.
- DO NOT USE COUNTERTOP SURFACE AS A WORK BENCH.

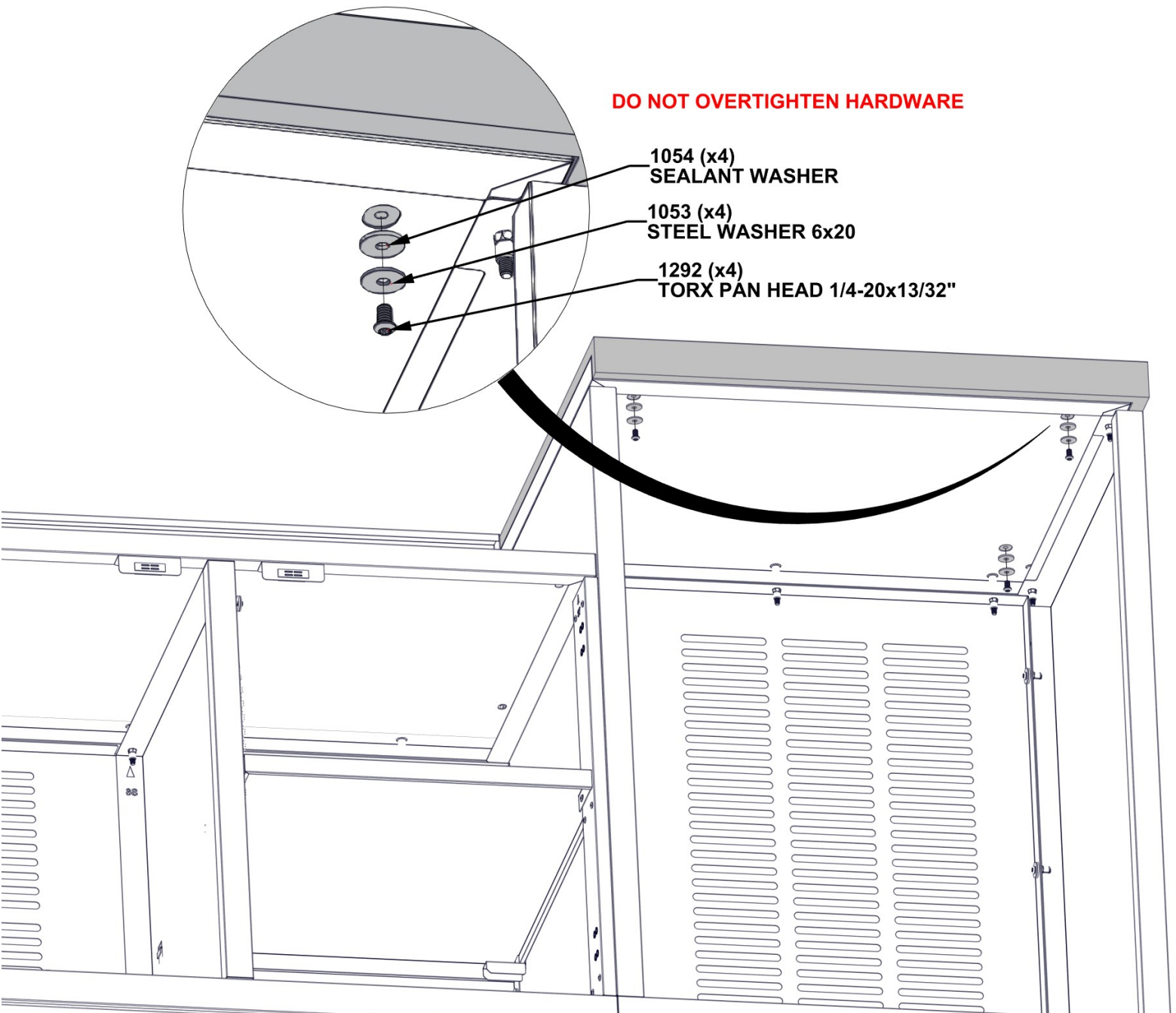

STEP 29A - SINK COUNTERTOP INSTALLATION

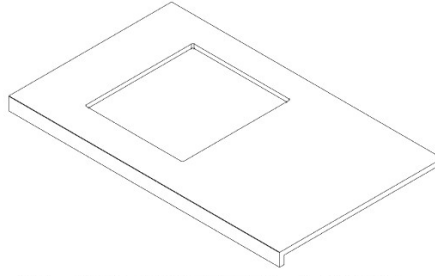

M7 SINK COUNTERTOP - A4M06201
(x1) 37 3/16" x 24 15/16" x 1 15/16" (50x634x944)

- IT IS RECOMMENDED TO HAVE AT LEAST TWO PEOPLE SET COUNTERTOP IN PLACE.
- SLIDE IN PLACE UNTIL COUNTERTOP IS TIGHT AGAINST CABINET AND SIDES ARE FLUSH WITH PANEL.
- **WHEN SETTING COUNTERTOP IN PLACE, MAKE SURE YOUR FINGERS ARE CLEAR AND NOT UNDERNEATH.**

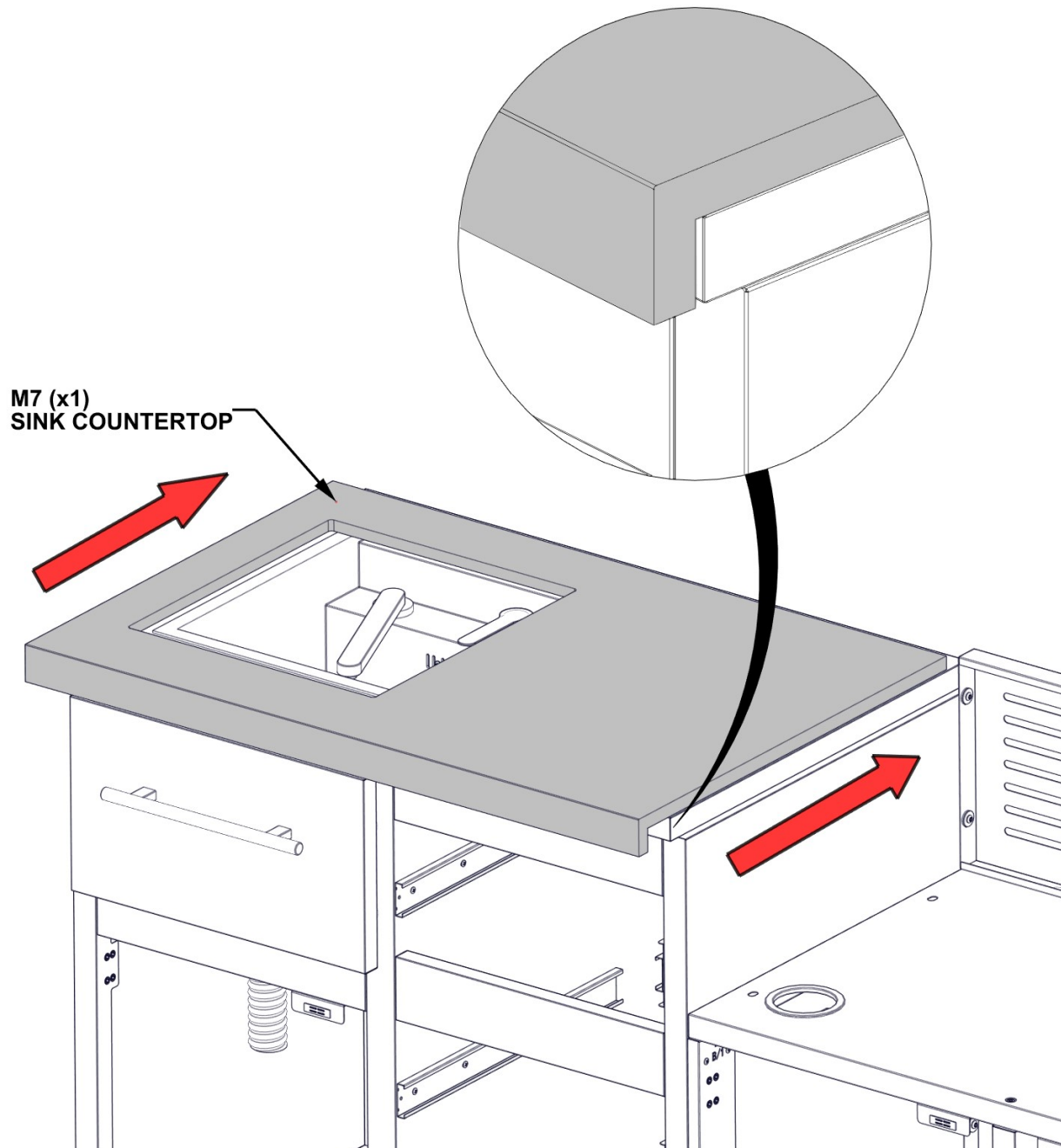

STEP 29B - SINK COUNTERTOP INSTALLATION

Qty	PartNo	Description
4	H101292	TORX PAN HEAD 1/4-20x13/32"
4	H101053	STEEL WASHER 6x20
4	H101054	SEALANT WASHER

- IT IS RECOMMENDED TO USE 6" BIT EXTENDER FOR THIS STEP.

- MAKE SURE YOU ARE USING THE CORRECT HARDWARE FOR THIS STEP.
- ONCE COUNTERTOP IS IN PLACE, IT IS RECOMMENDED TO COVER WITH A PIECE OF CARDBOARD OR FOAM UNTIL ASSEMBLY IS FINISHED TO PREVENT DAMAGE.
- DO NOT USE COUNTERTOP SURFACE AS A WORK BENCH.

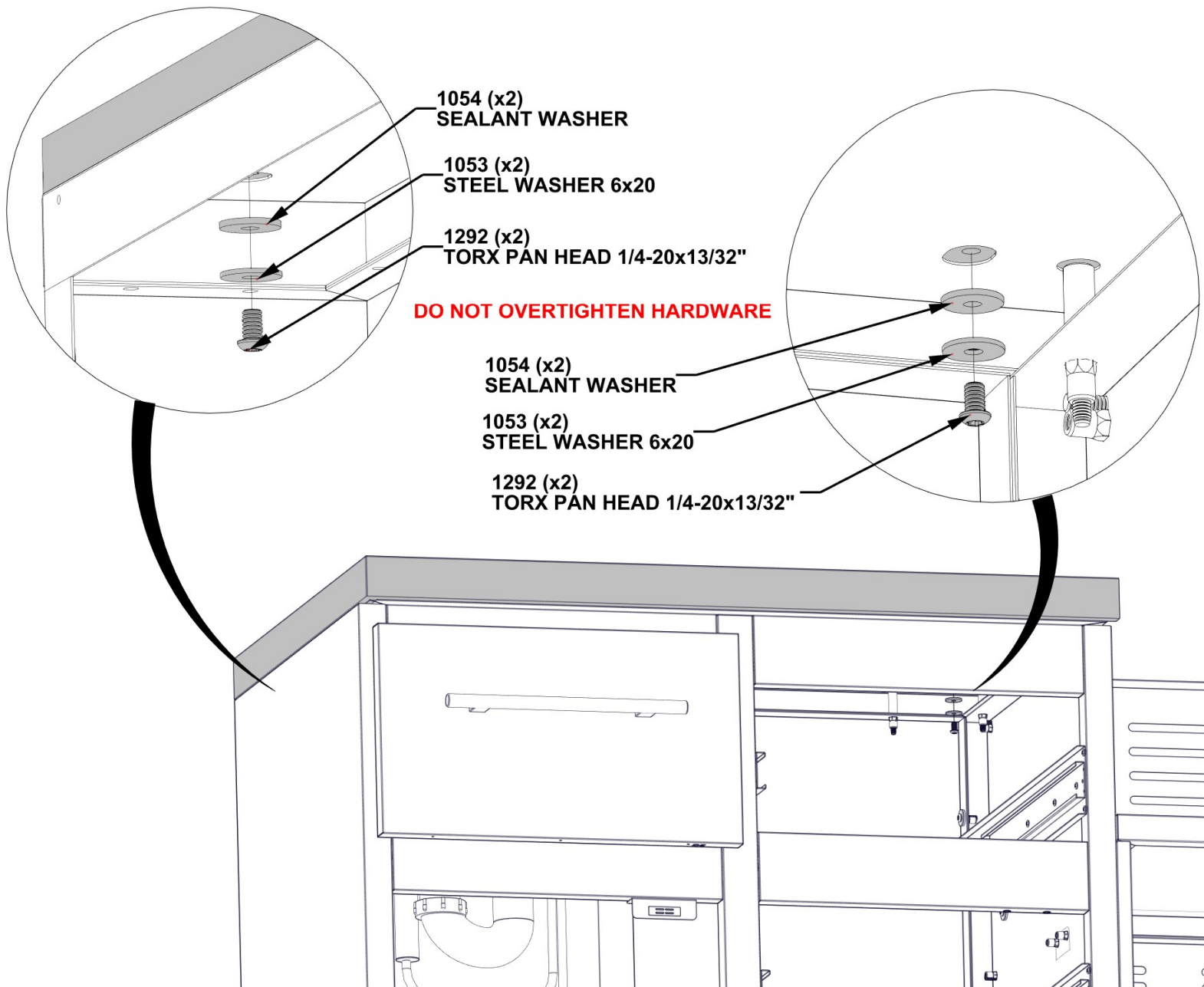

STEP 30 - SINK COUNTERTOP INSTALLATION

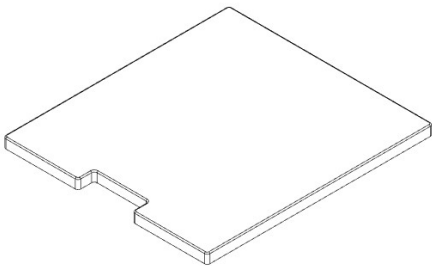

M5 SINK COVER COUNTERTOP - A4M05949
(x1) 11/16"x14 3/4"x16 5/16" (18x375x415)

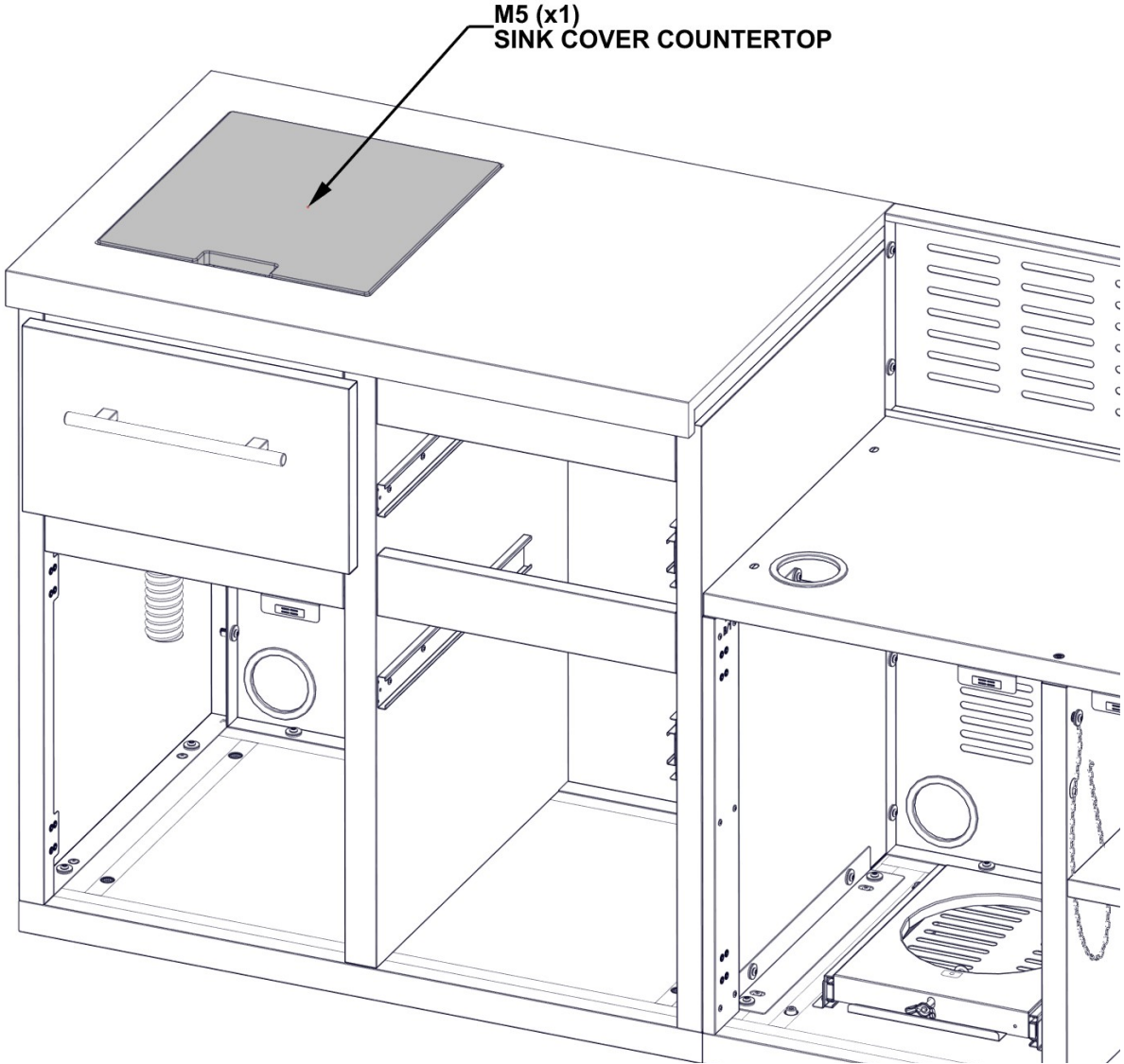

STEP 31A - KITCHEN TRASH CAN ASSEMBLY

Qty	PartNo	Description
6	H101289	PAN HEAD SCREW 8-32x1/2" SS

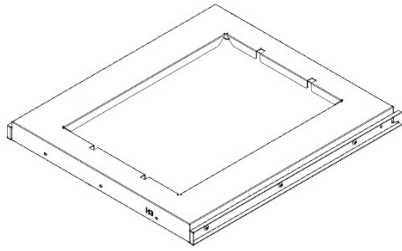

H3 TRASH CAN BRACKET ASSEMBLY - A4M03610
 (x1) 18 1/16"x15 13/16"x (35x401.60x458)



A11 TRIANGLE PANEL - A4M03086
 (x2) 13/16"x13 3/4"x13 3/4" (20x350x350)

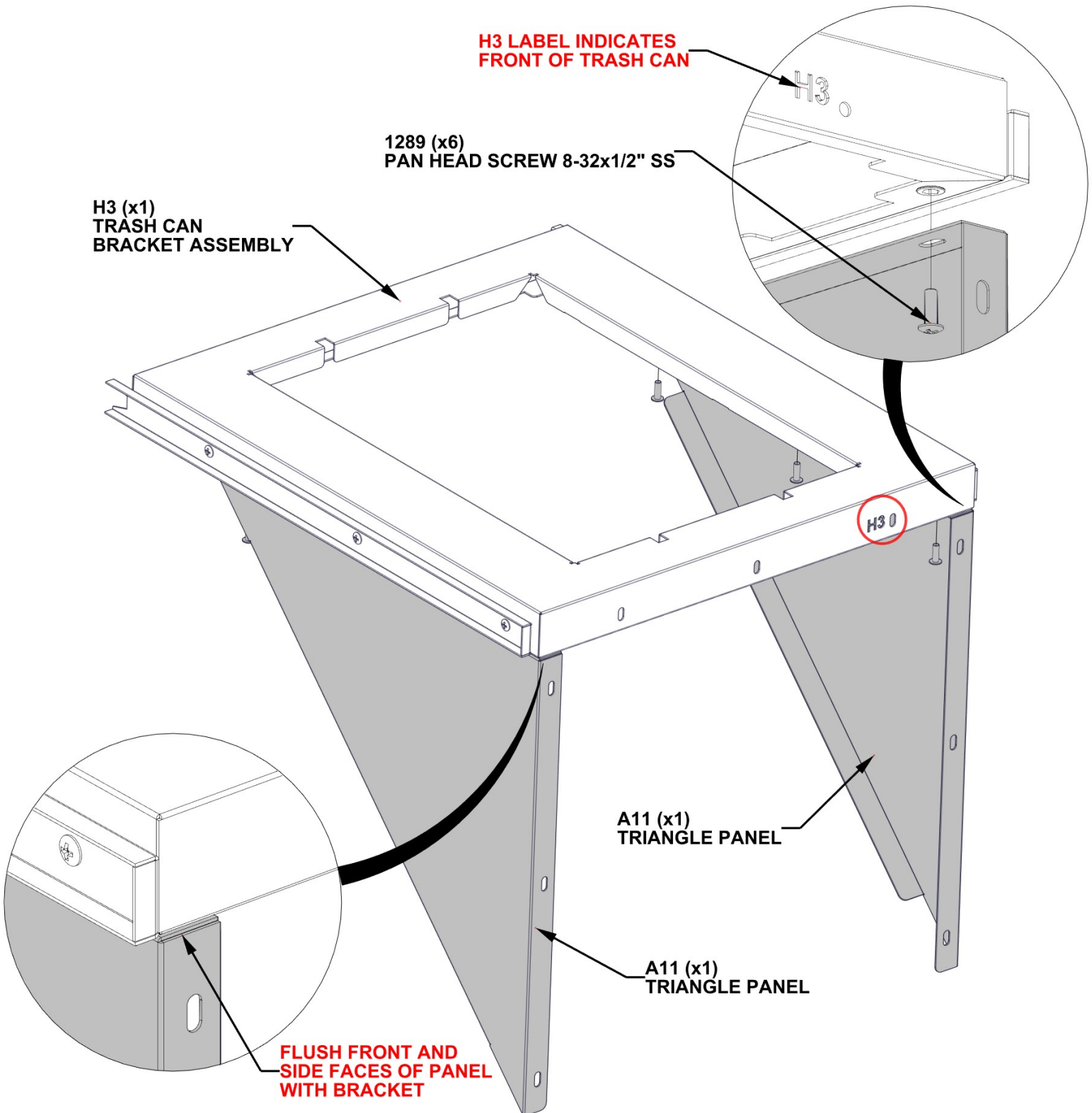

STEP 31B - KITCHEN TRASH CAN ASSEMBLY

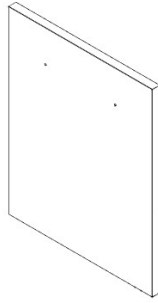

Qty	PartNo	Description
9	H101289	PAN HEAD SCREW 8-32x1/2" SS

D9 TRASH CAN PANEL ASSEMBLY - A4M03608
(x1) 22 1/4"x17 3/4"x15/16" (24.00x451.00x565.00)

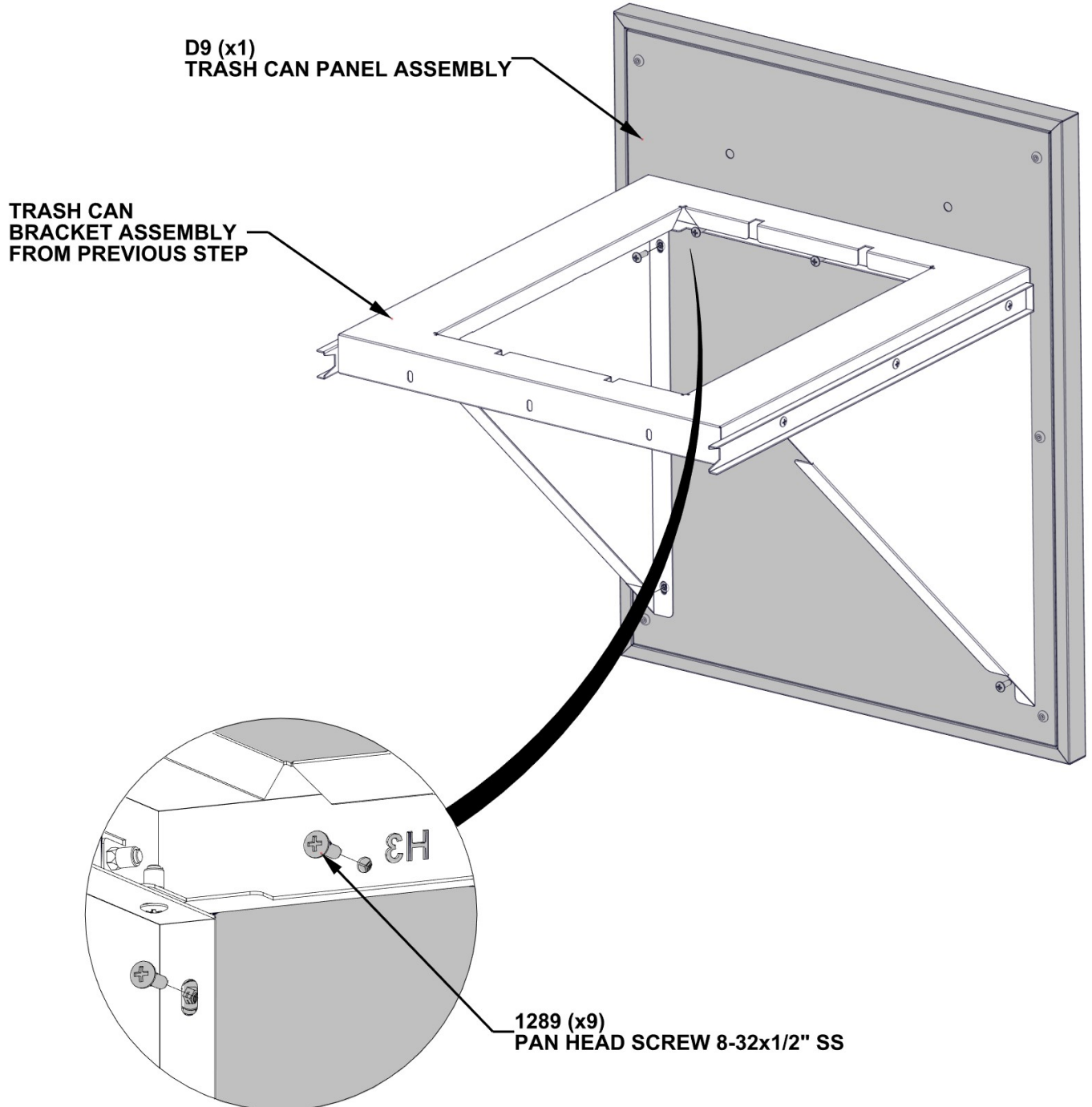

STEP 31C - KITCHEN TRASH CAN ASSEMBLY

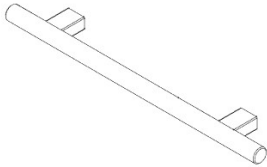

Qty	PartNo	Description
2	H101307	SHOULDER BOLT 8-32x30mm SS

H2 STAINLESS STEEL HANDLE - A4M03024
 (x1) 5/8"x1 9/16"x11 13/16" (16x40x300)

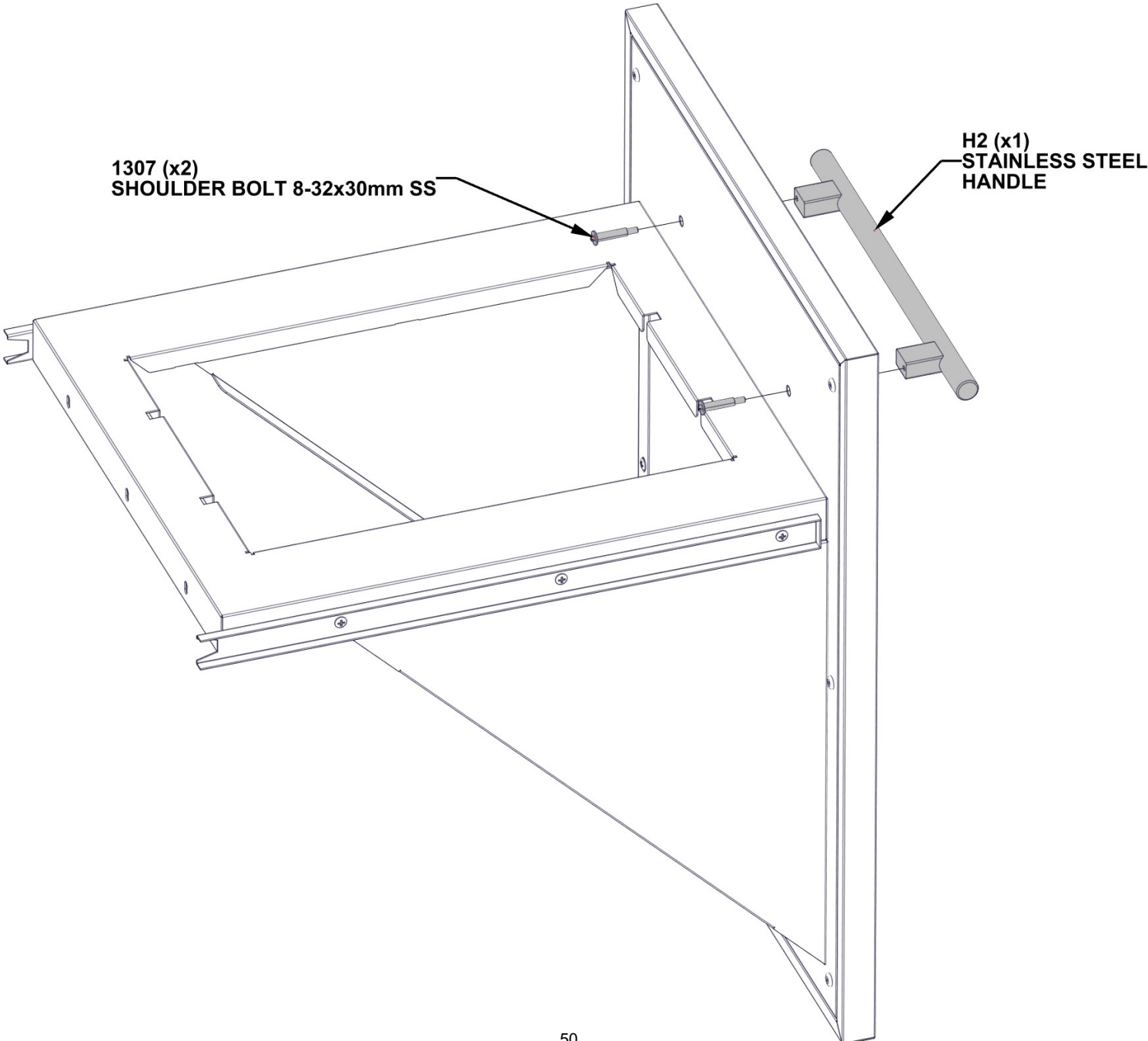

STEP 32 - KITCHEN TRASH CAN INSTALLATION

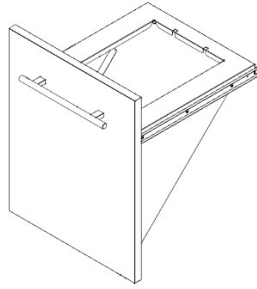

TRASH CAN ASSEMBLY
FROM STEP 31

- ATTACH TRASH CAN ASSEMBLY BY ALIGNING BOTH ENDS OF FACTORY ASSEMBLED DRAWER SLIDES WITH ONE ANOTHER.
- PRESS TOGETHER UNTIL DRAWER SLIDES CONNECT.

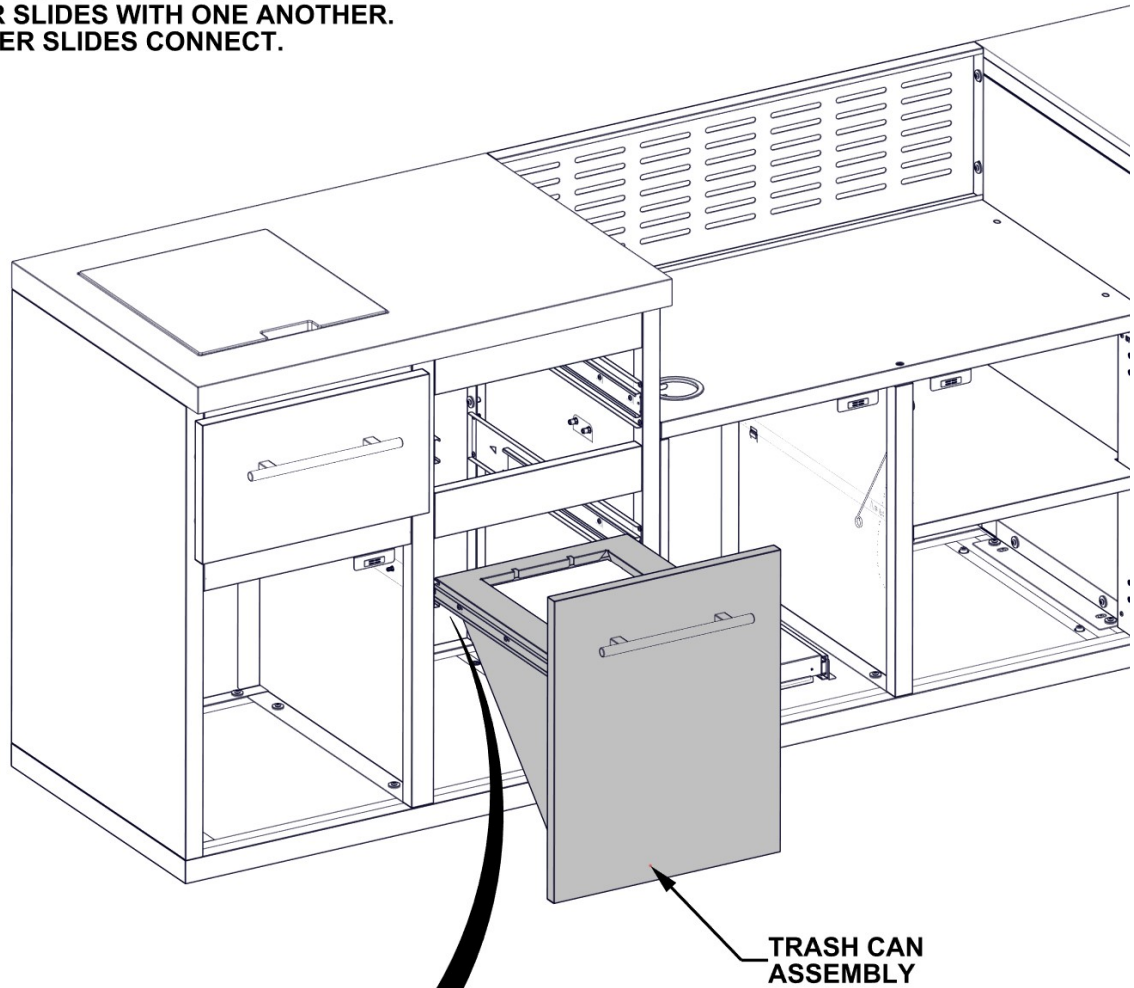

TRASH CAN
ASSEMBLY

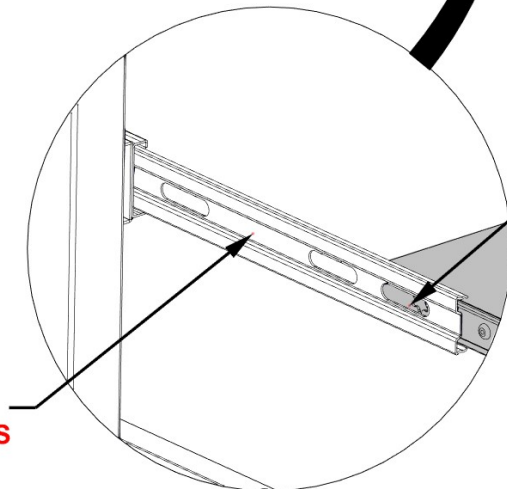

SLIDE INNER RACE
OF DRAWER SLIDE OUT
BEFORE ATTACHING SLIDES

ALIGN DRAWER SLIDES
ON BOTH SIDES OF TRASH
CAN HOLDER

STEP 33A - KITCHEN DRAWER ASSEMBLY

Qty	PartNo	Description
9	H101289	PAN HEAD SCREW 8-32x1/2" SS

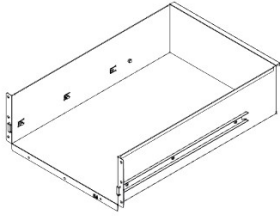

D4 CABINET DRAWER BODY ASSEMBLY - A4M03571
 (x1) 22 1/4"x16 1/16"x6 7/16" (164.2x408.4x565.4)

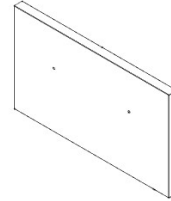

D3 CABINET DRAWER PANEL ASSEMBLY - A4M03569
 (x1) 17 3/4"x10 1/4"x15/16" (24x260x451)

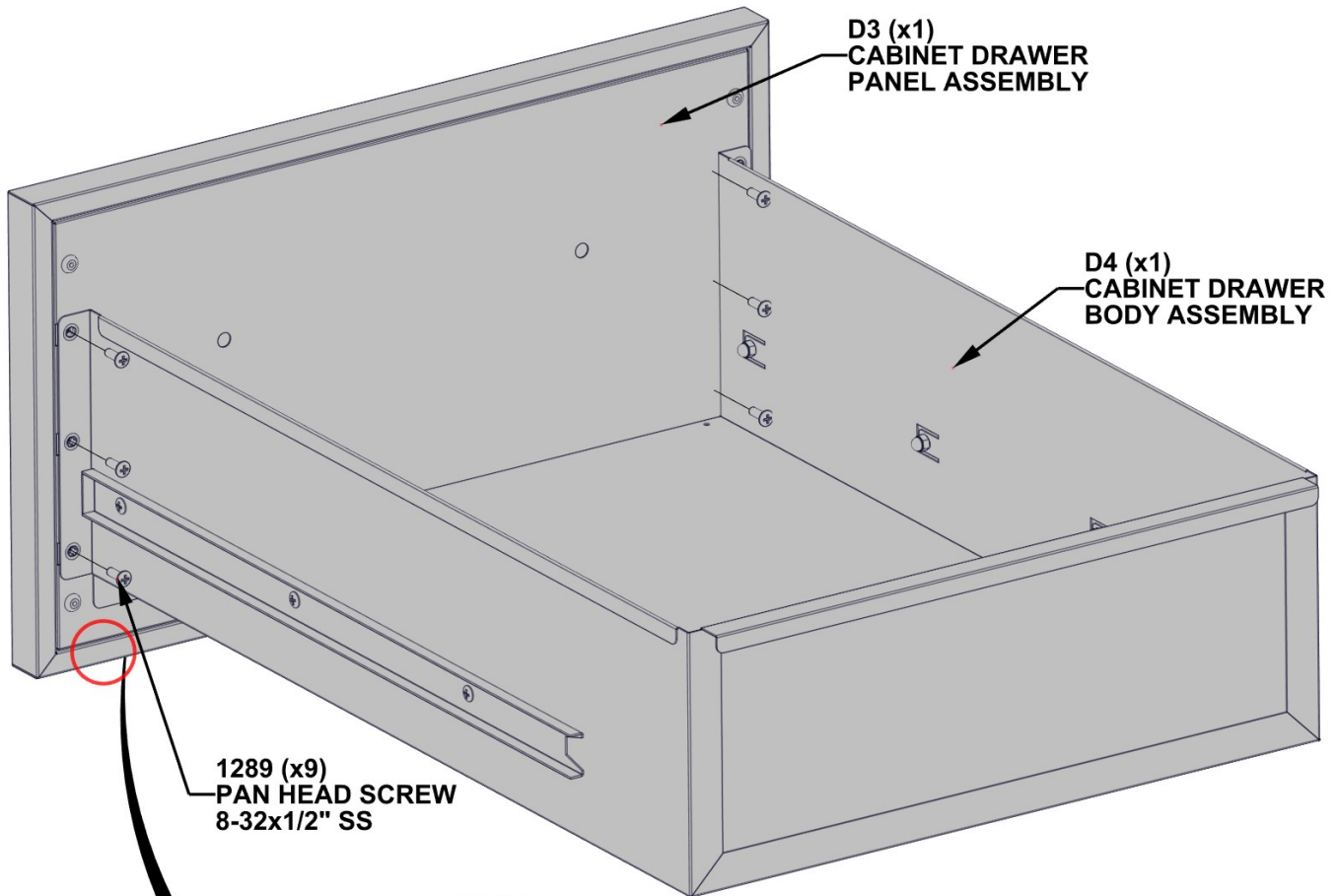

**1289 (x9)
PAN HEAD SCREW
8-32x1/2" SS**

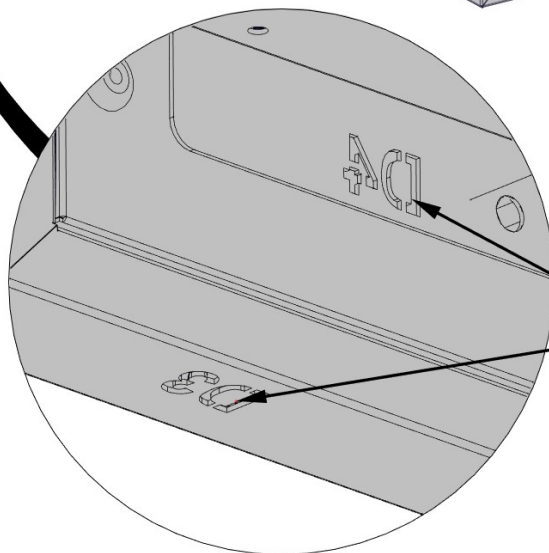

**D3 AND D4 LABELS INDICATE
BOTTOM OF DRAWER**

STEP 33B - KITCHEN DRAWER ASSEMBLY

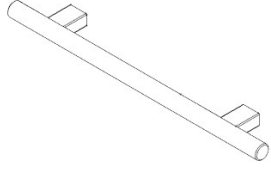

Qty	PartNo	Description
2	H101307	SHOULDER BOLT 8-32x30mm SS

H2 STAINLESS STEEL HANDLE - A4M03024
(x1) 5/8"x1 9/16"x11 13/16" (16x40x300)

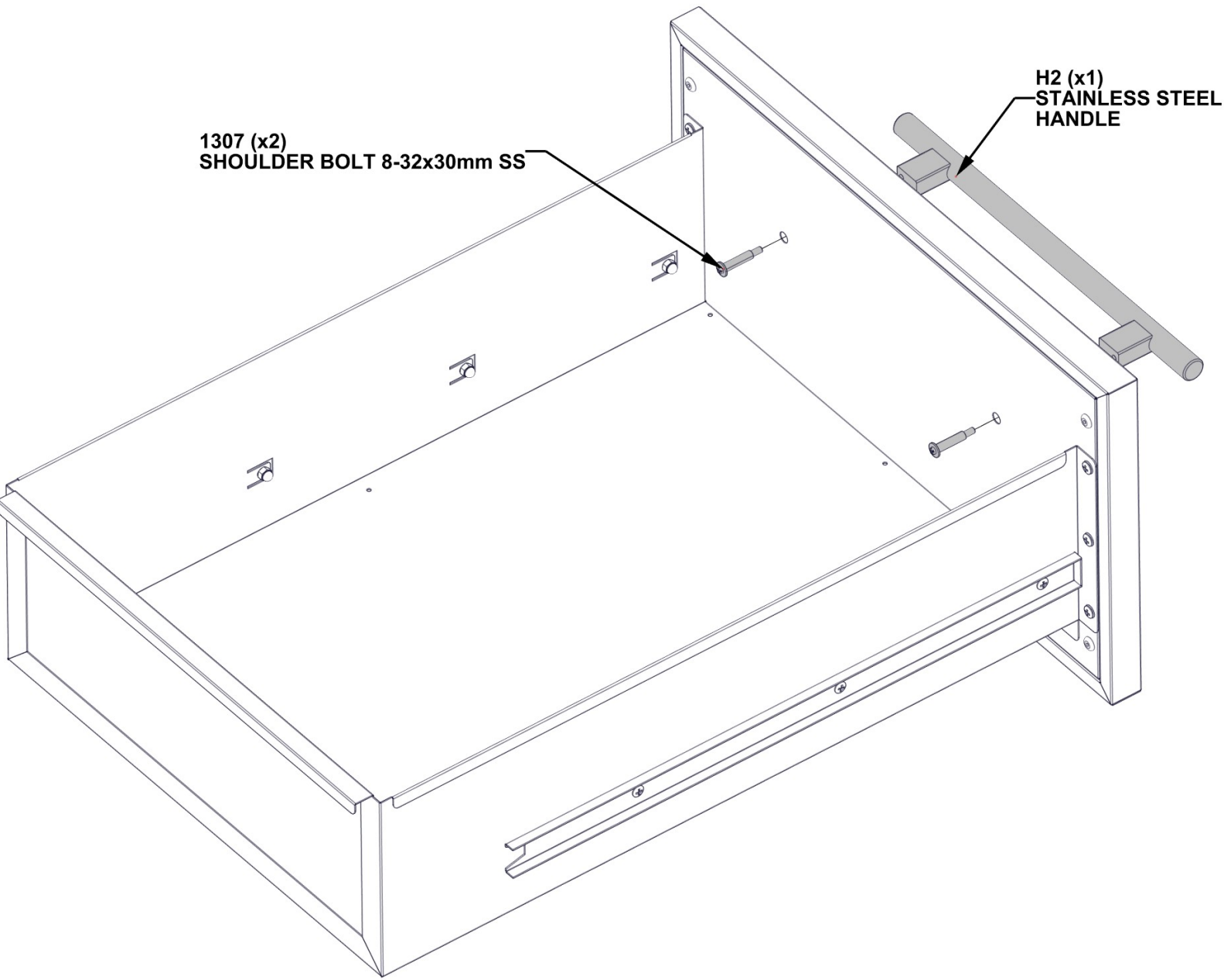

STEP 34 - KITCHEN DRAWER INSTALLATION

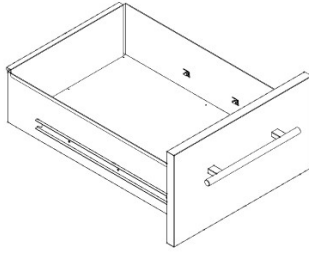

DRAWER ASSEMBLY
FROM STEP 33

- ATTACH DRAWER ASSEMBLY BY ALIGNING BOTH ENDS OF FACTORY ASSEMBLED DRAWER SLIDES WITH ONE ANOTHER.
- PRESS TOGETHER UNTIL DRAWER SLIDES CONNECT.

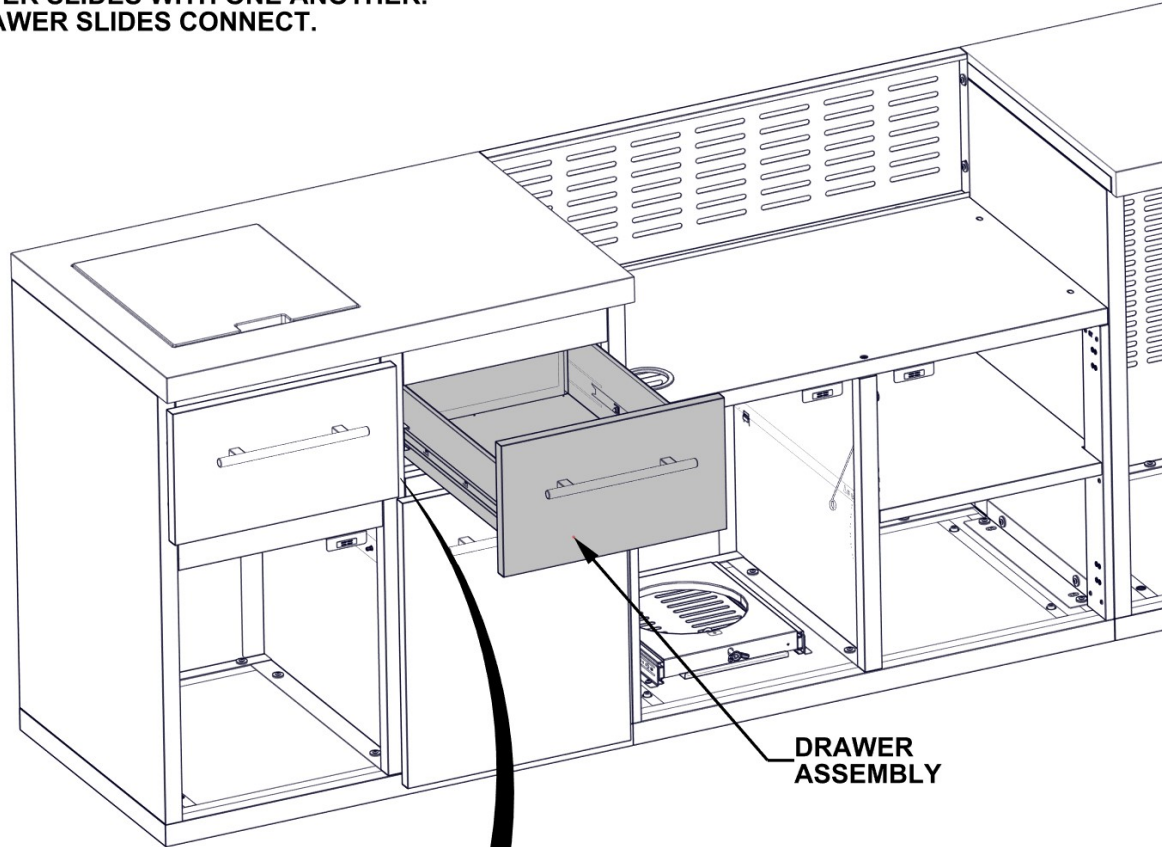

DRAWER
ASSEMBLY

SLIDE INNER RACE
OF DRAWER SLIDE OUT
BEFORE ATTACHING SLIDES

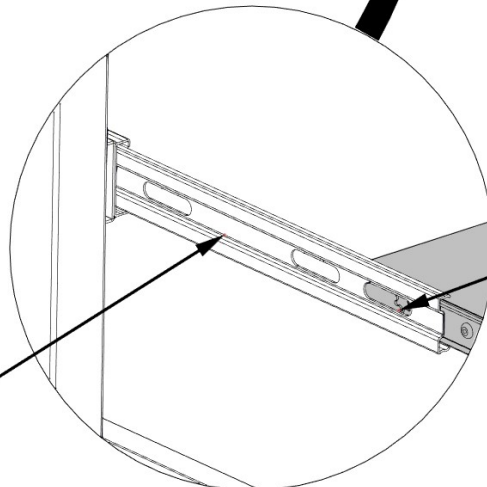

ALIGN DRAWER SLIDES
ON BOTH SIDES OF TRASH
CAN HOLDER

STEP 35A - DOOR ASSEMBLY

Qty	PartNo	Description
12	H101185	PHILLIPS FLAT HEAD 8-32x.5 SCREW

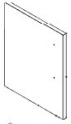

D6 CABINET DOOR ASSEMBLY L - A4M03577
(x1) 22 1/4"x17 13/16"x15/16" (24x452x565)

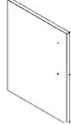

D7 CABINET DOOR ASSEMBLY L - A4M03587
(x1) 24 13/16"x19 1/16"x15/16" (24x484.15x630)



D8 CABINET DOOR ASSEMBLY R - A4M03590
(x1) 24 13/16"x19 1/16"x15/16" (24x484.15x630)



A4M03025 FULL OVERLAY HINGE
(x6)

- INSTALL CABINET HINGES TO THE THREE DOORS.

DO NOT OVERTIGHTEN HARDWARE

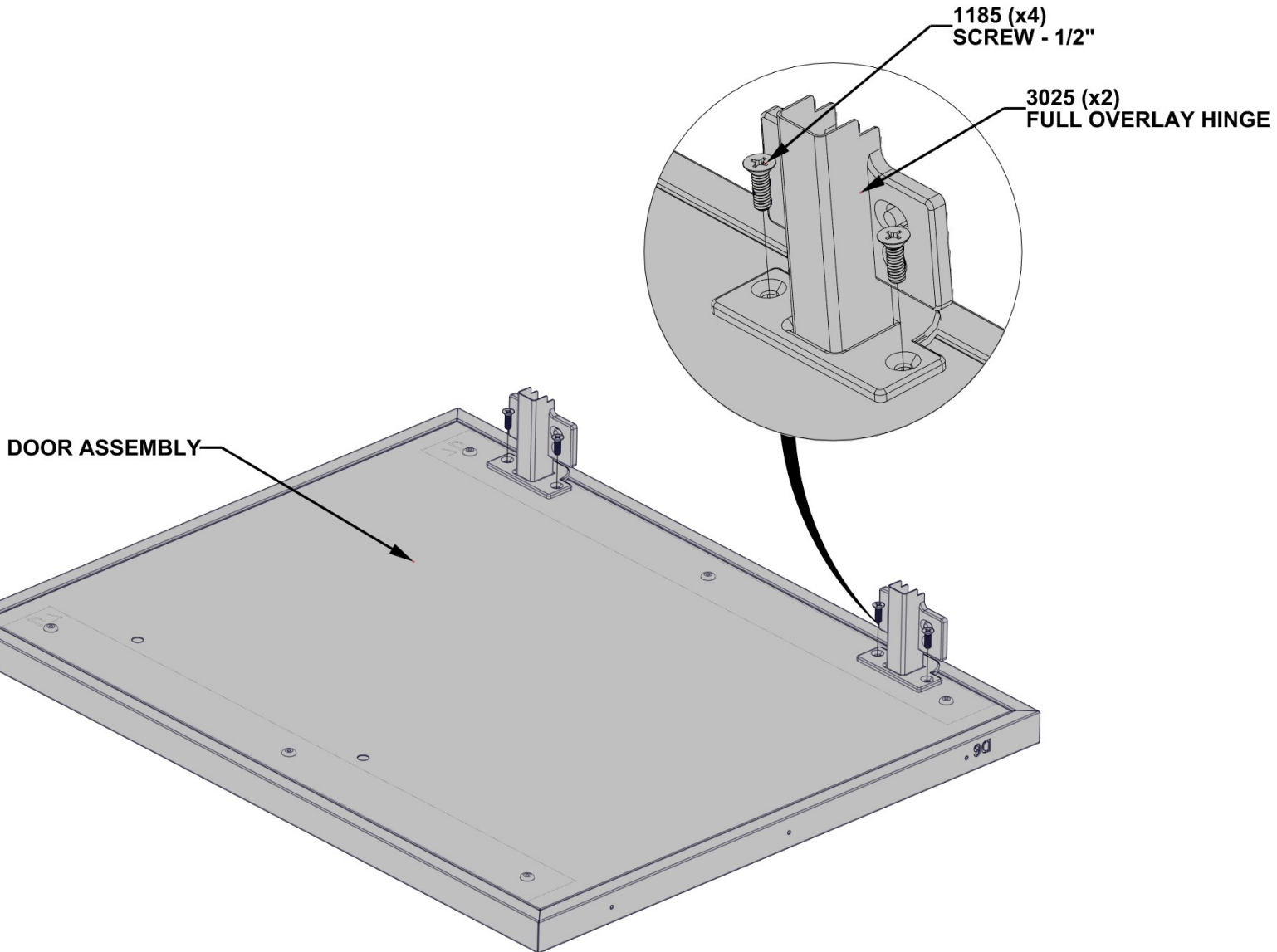

STEP 35B - DOOR ASSEMBLY

Qty	PartNo	Description
6	H101307	SHOULDER BOLT 8-32x30mm SS

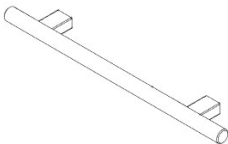

H2 STAINLESS STEEL HANDLE - A4M03024
(x3) 5/8"x1 9/16"x11 13/16" (16x40x300)

- INSTALL CABINET HANDLES ON THE THREE DOORS FROM PREVIOUS STEP.

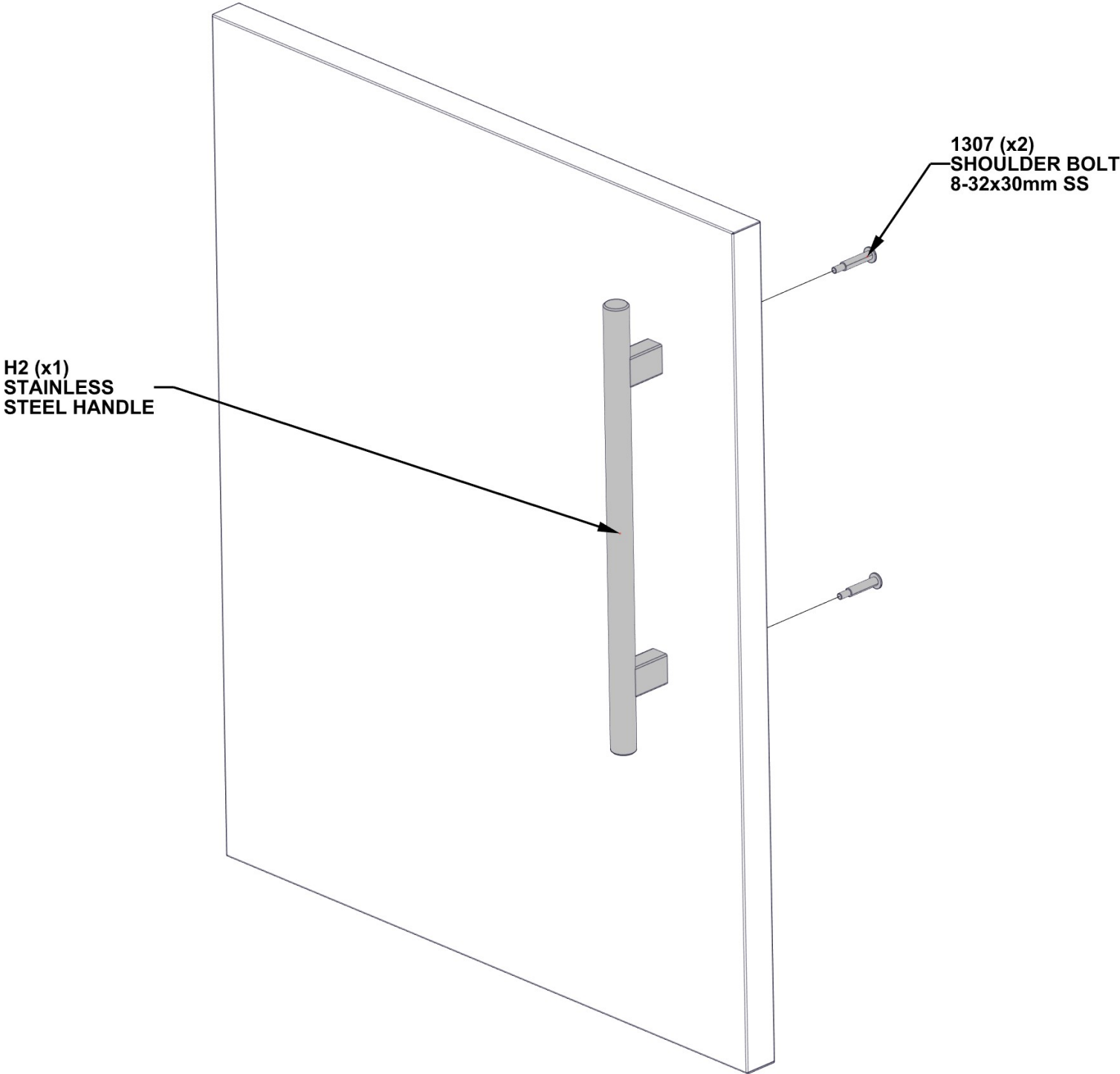

STEP 36 - CABINET DOOR ATTACHMENT

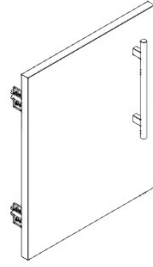

D6 CABINET DOOR ASSEMBLY L - A4M03577
(x1) 22 1/4"x17 13/16"x15/16" (24x452x565)

- FOR THIS STEP IT IS HELPFUL TO HAVE AN ADDITIONAL PERSON HELP HOLD DOOR IN PLACE.
- WITH CABINET HINGES ATTACHED TO DOOR, ALIGN HOLES IN HINGE BRACKET WITH THREADED INSERTS IN SIDE OF CABINET PANEL.

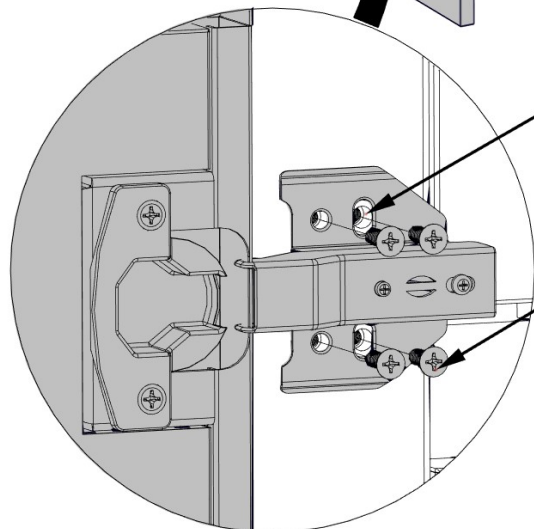
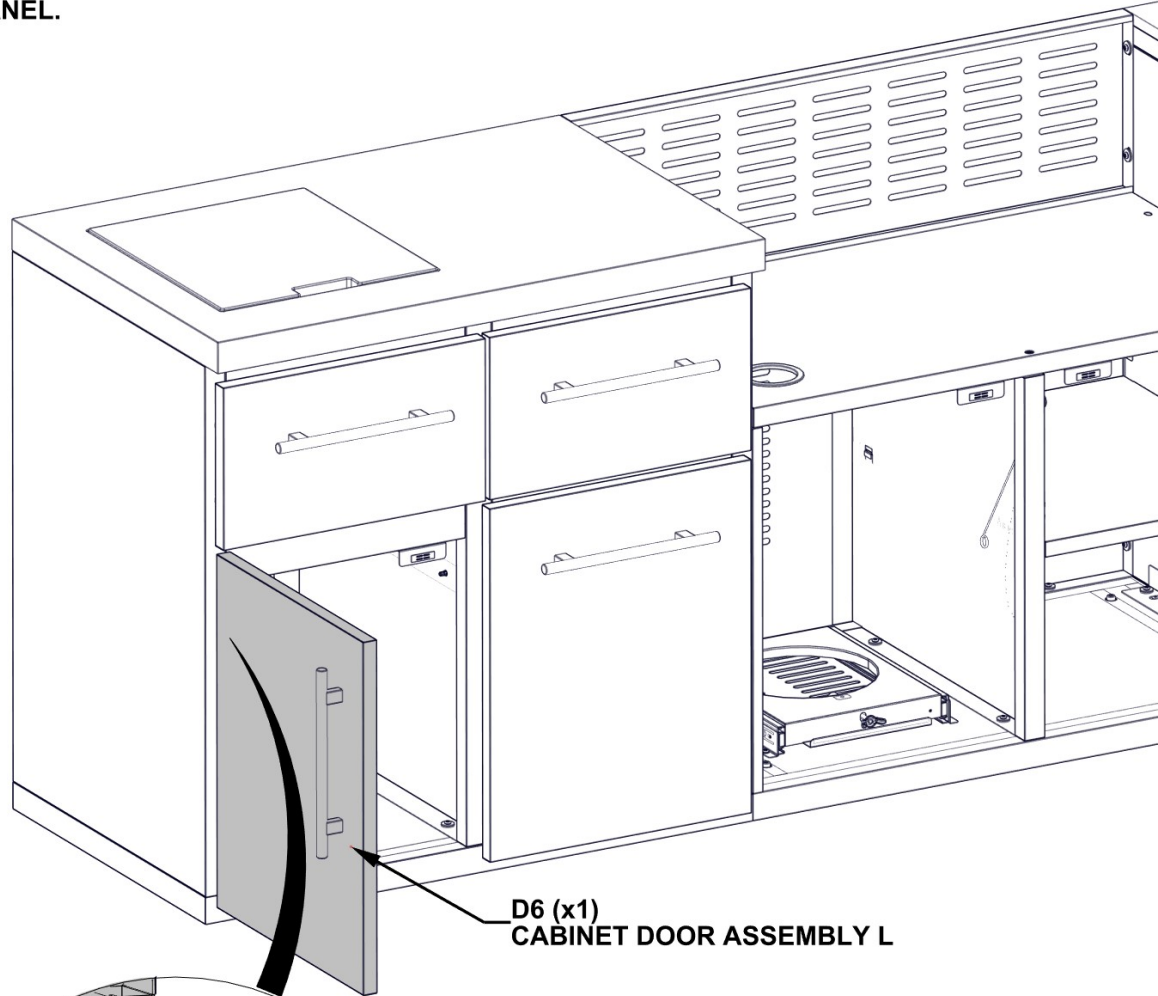

**ALIGN HINGE BRACKET WITH
THREADED INSERTS IN PANEL**

DO NOT OVERTIGHTEN HARDWARE

**1185 (x8)
SCREW - 1/2"**

STEP 37 - CABINET DOOR ATTACHMENT

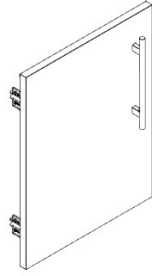

Qty	PartNo	Description
8	H101185	PHILLIPS FLAT HEAD 8-32x.5 SCREW

D7 CABINET DOOR ASSEMBLY L - A4M03587
(x1) 24 13/16"x19 1/16"x15/16" (24x484.15x630)

- FOR THIS STEP IT IS HELPFUL TO HAVE AN ADDITIONAL PERSON HELP HOLD DOOR IN PLACE.
- WITH CABINET HINGES ATTACHED TO DOOR, ALIGN HOLES IN HINGE BRACKET WITH THREADED INSERTS IN SIDE OF CABINET PANEL.

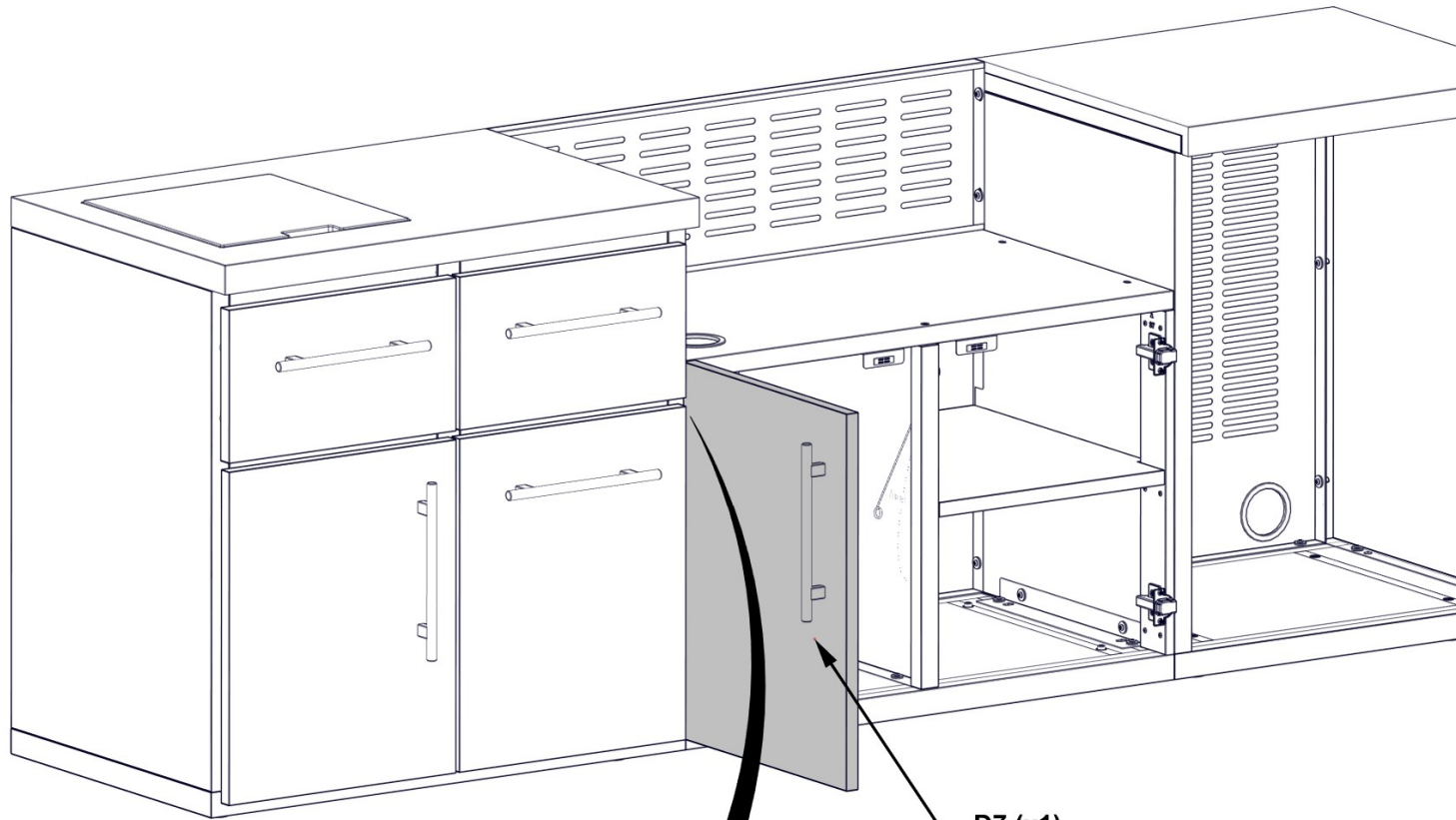

D7 (x1)
CABINET DOOR ASSEMBLY L

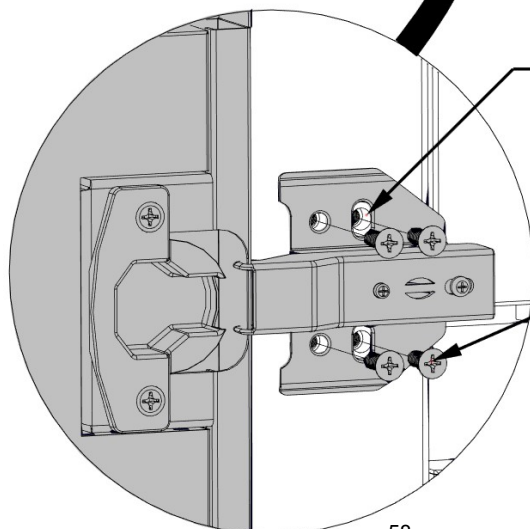

**ALIGN HINGE BRACKET WITH
THREADED INSERTS IN PANEL**

DO NOT OVERTIGHTEN HARDWARE

1185 (x8)
SCREW - 1/2"

STEP 38 - CABINET DOOR ATTACHMENT

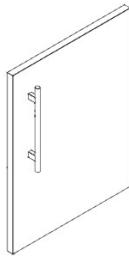

Qty	PartNo	Description
8	H101185	PHILLIPS FLAT HEAD 8-32x.5 SCREW

D8 CABINET DOOR ASSEMBLY R - A4M03590
(x1) 24 13/16"x19 1/16"x15/16" (24x484.15x630)

- FOR THIS STEP IT IS HELPFUL TO HAVE AN ADDITIONAL PERSON HELP HOLD DOOR IN PLACE.
- WITH CABINET HINGES ATTACHED TO DOOR, ALIGN HOLES IN HINGE BRACKET WITH THREADED INSERTS IN SIDE OF CABINET PANEL.

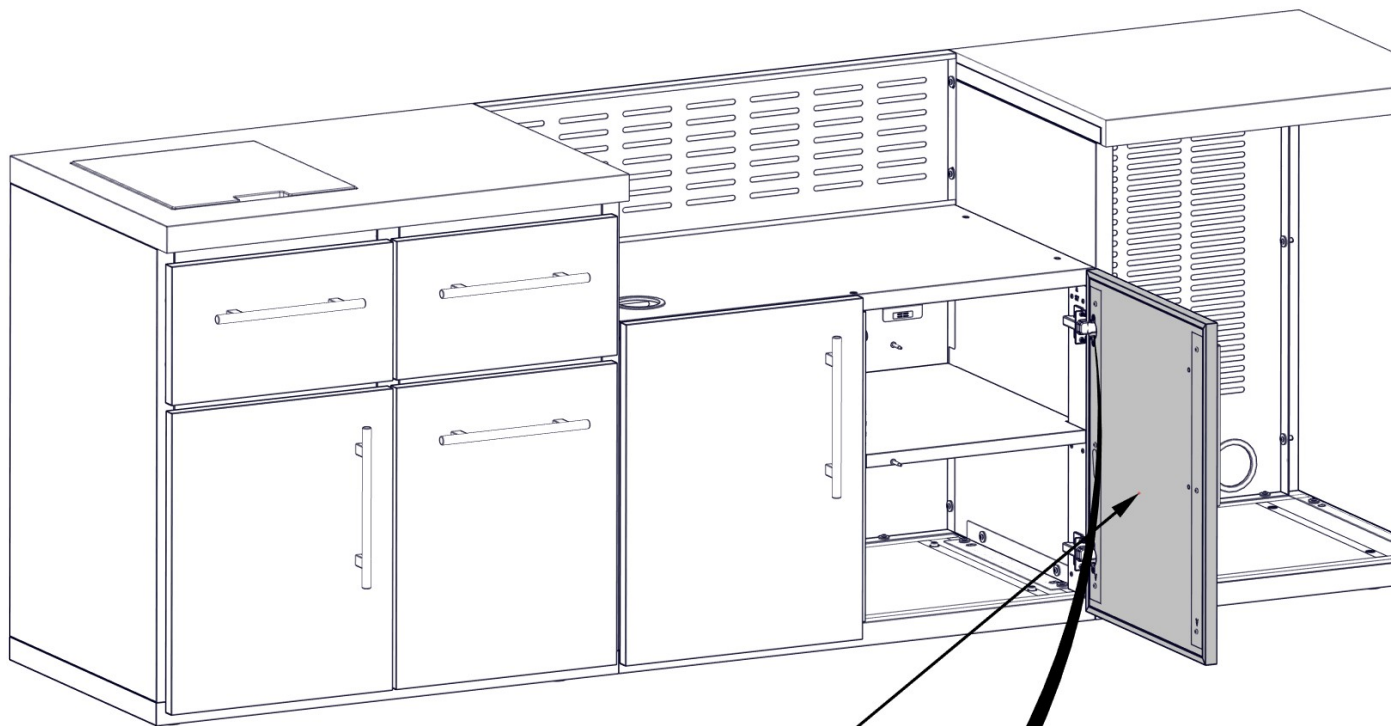

D8 (x1)
CABINET DOOR ASSEMBLY R

**ALIGN HINGE BRACKET WITH
THREADED INSERTS IN PANEL**

DO NOT OVERTIGHTEN HARDWARE

1185 (x8)
SCREW - 1/2"

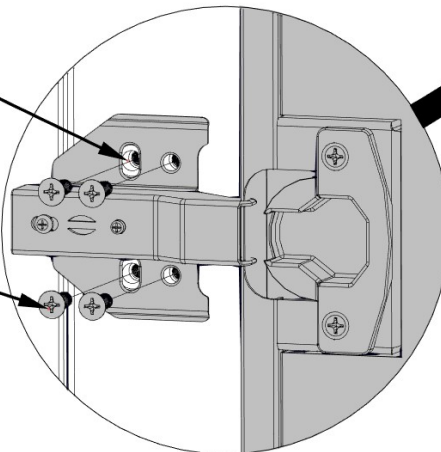

STEP 39 - CABINET DOOR ADJUSTMENT (AS NEEDED)

- ADJUST HINGES (AS NEEDED) SO THAT THE GAP AROUND ALL DOORS IS THE SAME AND THERE IS NO INTERFERENCE BETWEEN DOORS AND CABINETS.
- ADJUST MAGNET CATCH BRACKETS AS NEEDED.

**LOOSEN SCREWS TO ADJUST
MAGNET BRACKET, UNTIL IT
COMES IN CONTACT WITH
DOOR IN THE SHUT POSITION**

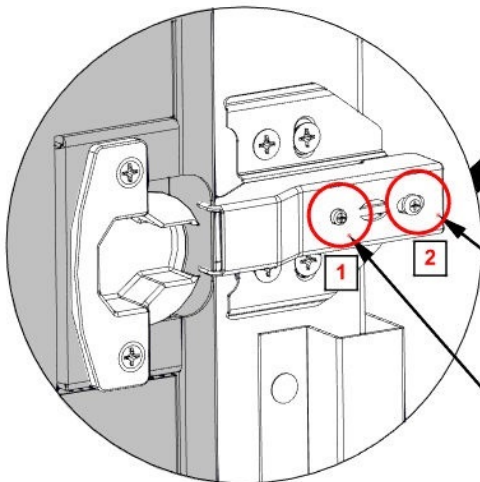
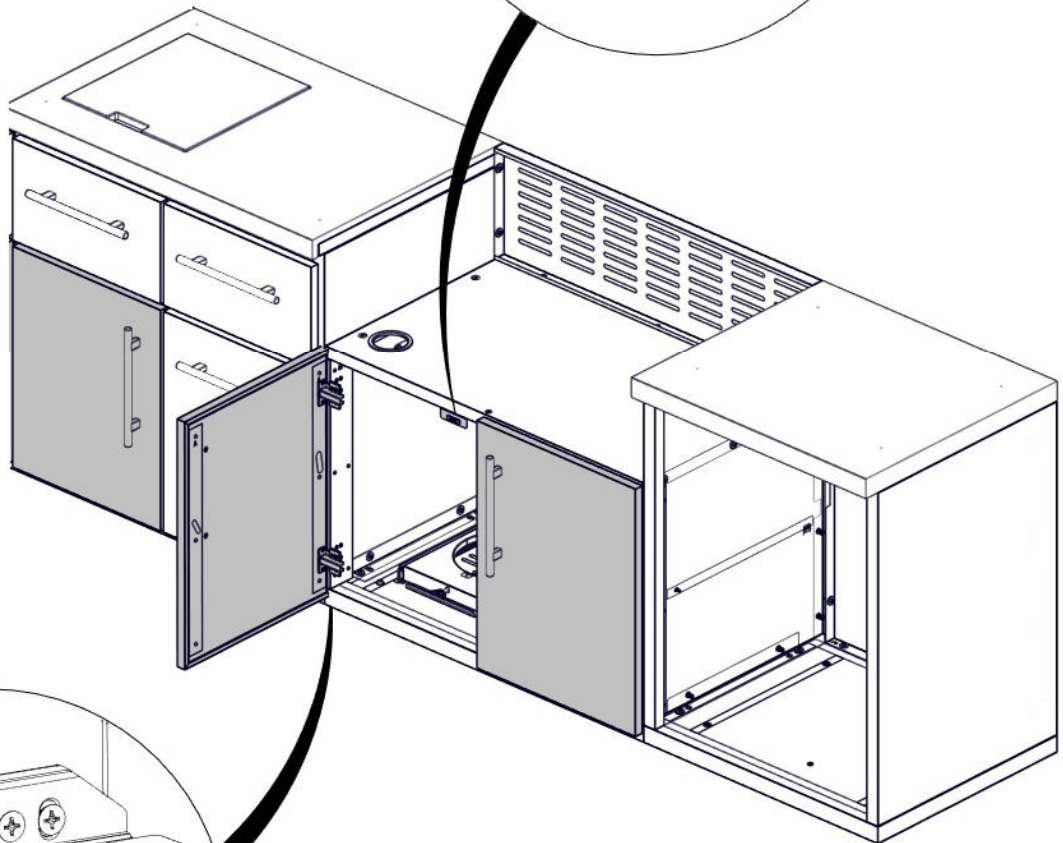
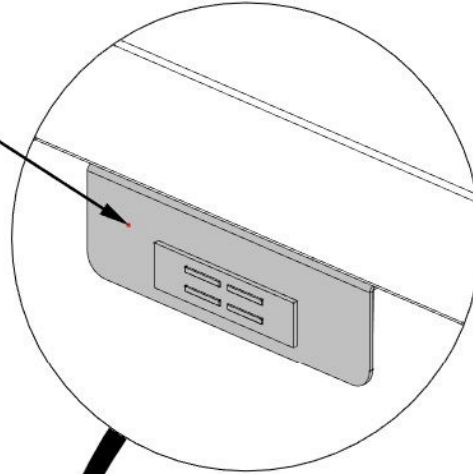

**SCREW #2:
LOOSEN THESE SCREWS TO
SLIDE DOOR TOWARD CABINET
OR AWAY FROM CABINET**

**SCREW #1:
SCREW CLOCKWISE TO BRING
EDGE OF DOOR AWAY FROM
CABINET. SCREW COUNTER
CLOCKWISE TO BRING EDGE OF
DOOR CLOSER TO CABINET**

STEP 40 - KITCHEN ACCESSORY

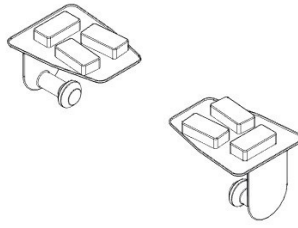

A4M02290 MAGNETIC PAPER TOWEL HOLDER
(x1)

- MAGNETIC PAPER TOWEL HOLDER CAN BE ATTACHED TO ANY METAL SURFACE ON KITCHEN.
- WE RECOMMEND ATTACHING TO THE INSIDE OF GRILL CABINET DOORS.
- **MAKE SURE TO KEEP PAPER TOWEL HOLDER AT A SAFE DISTANCE FROM GRILLING SURFACE.**

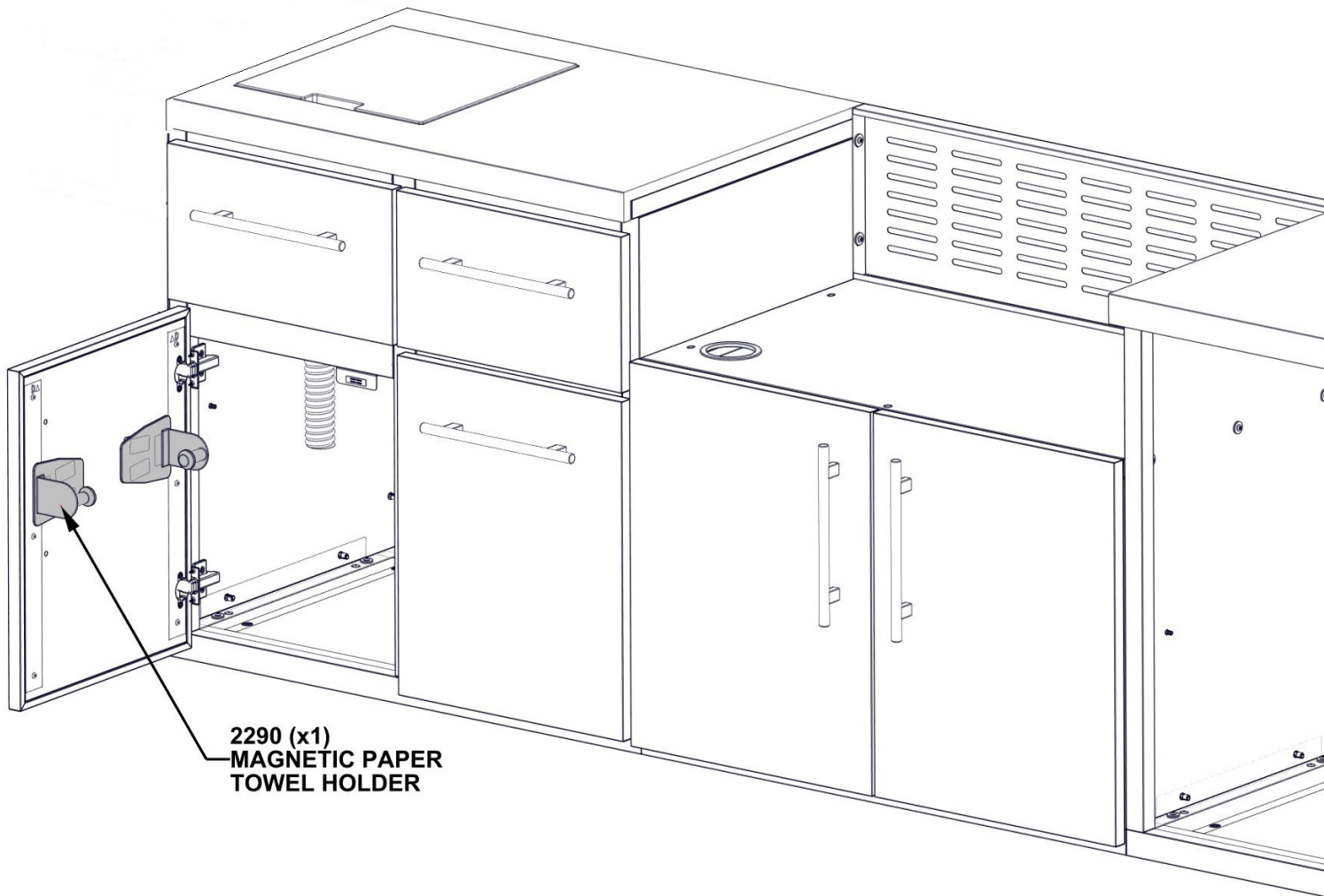

OUTDOOR KITCHEN FRIDGE

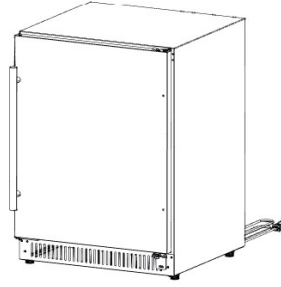

9240162 OUTDOOR KITCHEN FRIDGE - RIGHT OPEN
(x1)

-
- FOR INSTALLATION OF OUTDOOR KITCHEN FRIDGE, REFER TO PAGES IN THIS INSTRUCTION MANUAL.
 - FOR DETAILED INFORMATION OF OUTDOOR KITCHEN FRIDGE, REFER TO ASSEMBLY INSTRUCTIONS THAT COME PACKAGED WITH THE OUTDOOR KITCHEN FRIDGE.
 - FOLLOW DIRECTIONS FOR PROPER CARE AND USE.

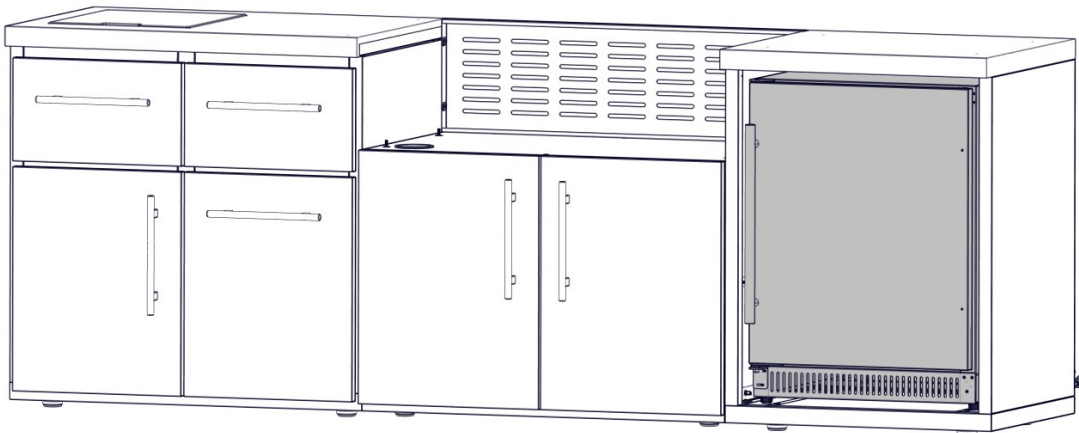

OUTDOOR KITCHEN FRIDGE

- CAREFULLY SLIDE FRIDGE INTO CABINET OPENING MAKING SURE THAT THE ELECTRICAL CORD IS ROUTED THROUGH THE HOLES IN THE BACK PANEL OF THE CABINET.

- IF FRIDGE IS NOT IN UPRIGHT POSITION, PLEASE LET SIT FOR 24 HRS BEFORE PLUGGING INTO RECEPTACLE.

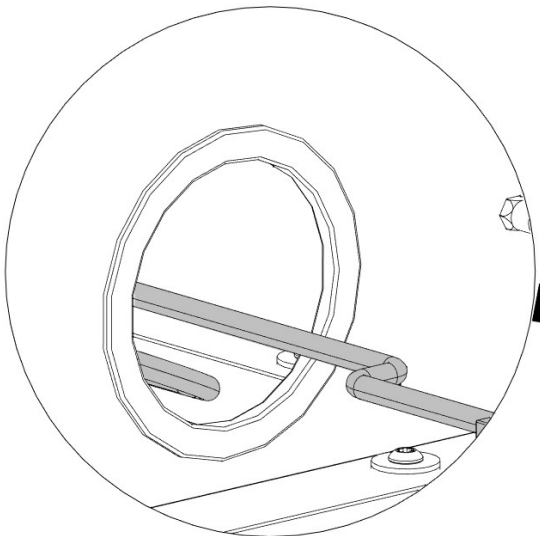
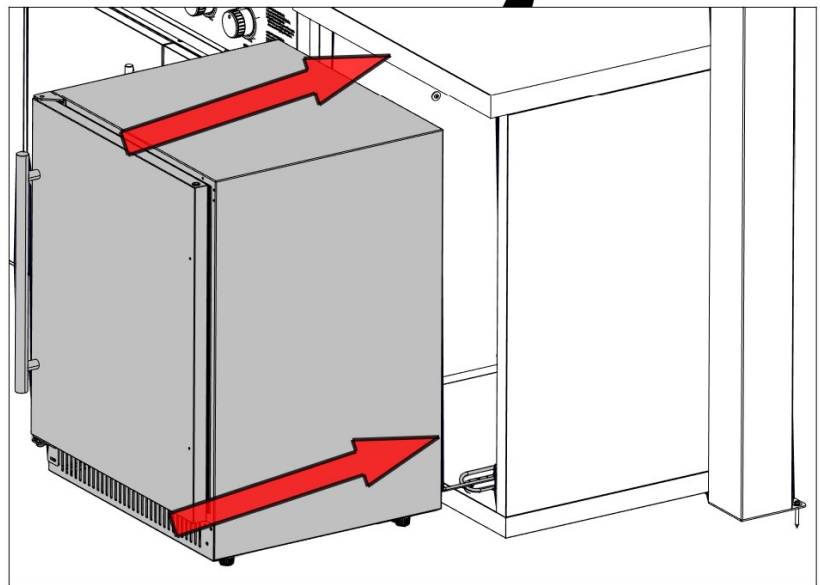
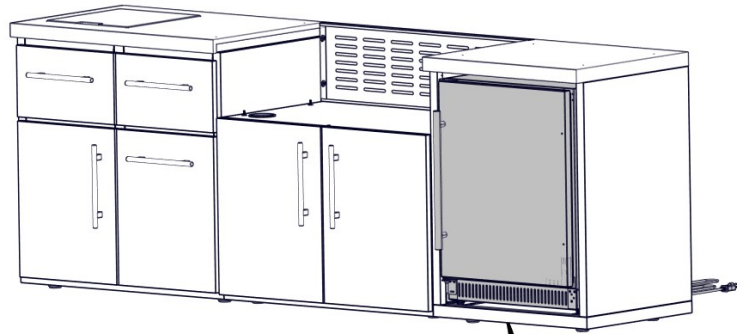

OUTDOOR KITCHEN FRIDGE

- ALIGN FEET ON FRIDGE UNIT SO THAT IT IS LEVEL AND DOES NOT TILT.
- TURN FEET CLOCKWISE TO EXTEND THEM AND COUNTERCLOCKWISE TO SHORTEN. REPEAT THIS FOR ALL FOUR FRIDGE FEET AS NEEDED TO LEVEL.

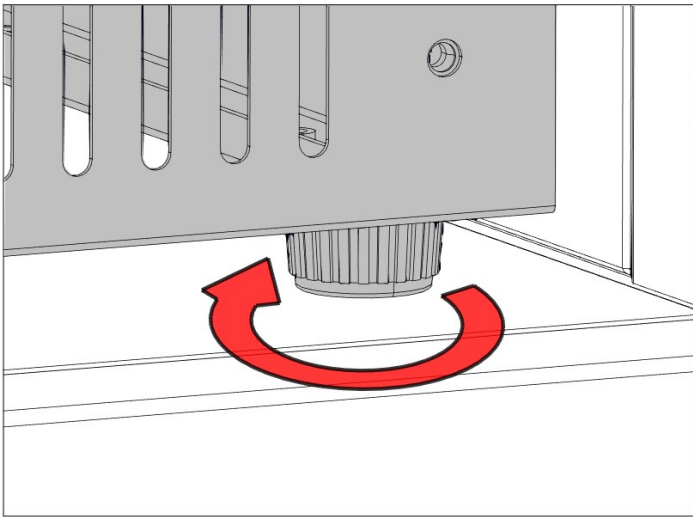
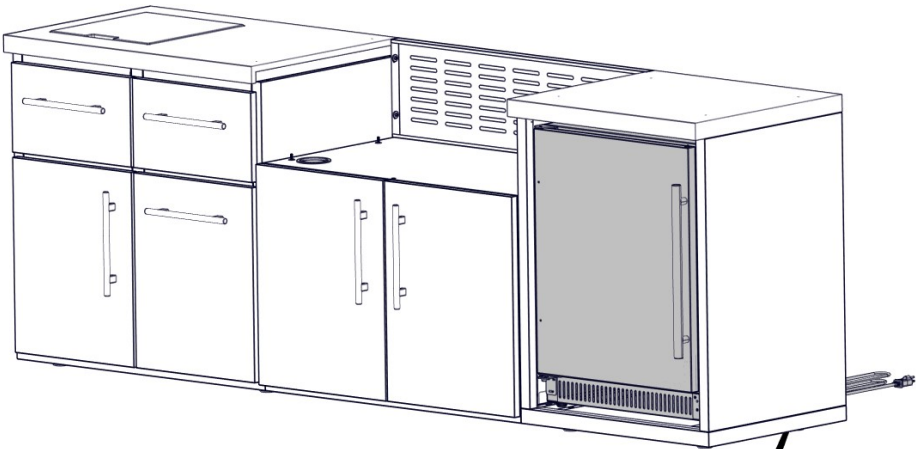

OUTDOOR KITCHEN APPLIANCE INSTALLATION

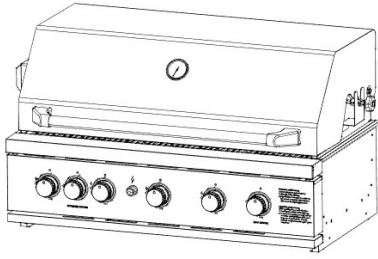

9240025 OUTDOOR KITCHEN GRILL KIT
(x1)

OR

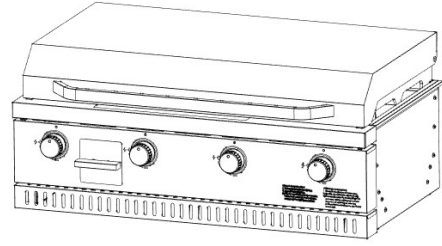

9240742 38" OUTDOOR KITCHEN GRIDDLE KIT
(x1)

- FOR INSTALLATION AND DETAILED INFORMATION OF OUTDOOR KITCHEN GRILL KIT, REFER TO ASSEMBLY INSTRUCTIONS THAT COME PACKAGED WITH THE OUTDOOR KITCHEN GRILL KIT.
- FOLLOW DIRECTIONS FOR PROPER CARE AND USE.

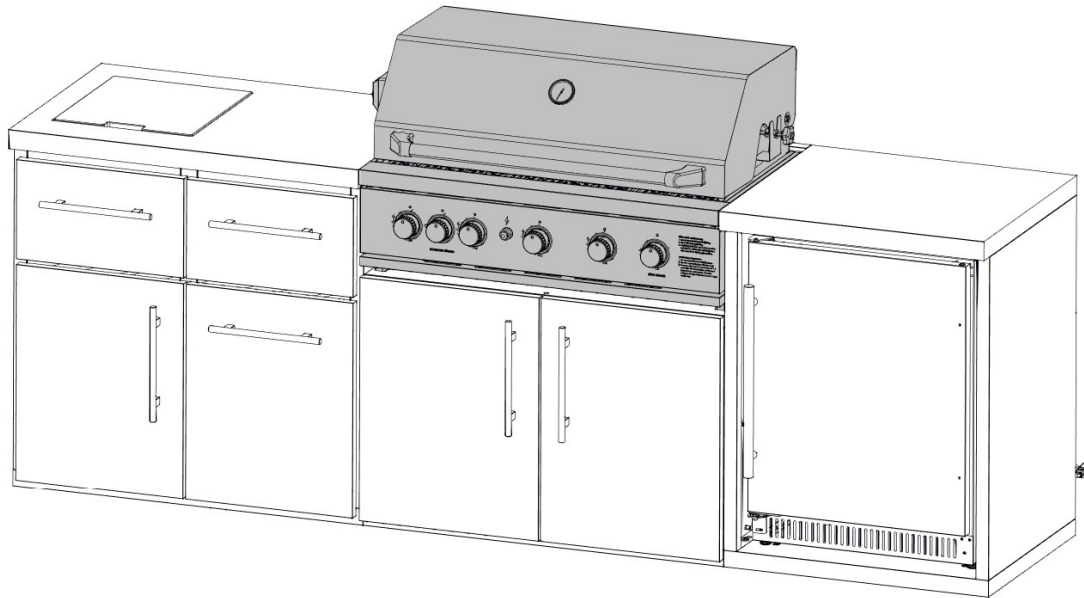

- FOR INSTALLATION AND DETAILED INFORMATION OF OUTDOOR KITCHEN GRIDDLE KIT, REFER TO ASSEMBLY INSTRUCTIONS THAT COME PACKAGED WITH THE OUTDOOR KITCHEN GRIDDLE KIT.
- FOLLOW DIRECTIONS FOR PROPER CARE AND USE.

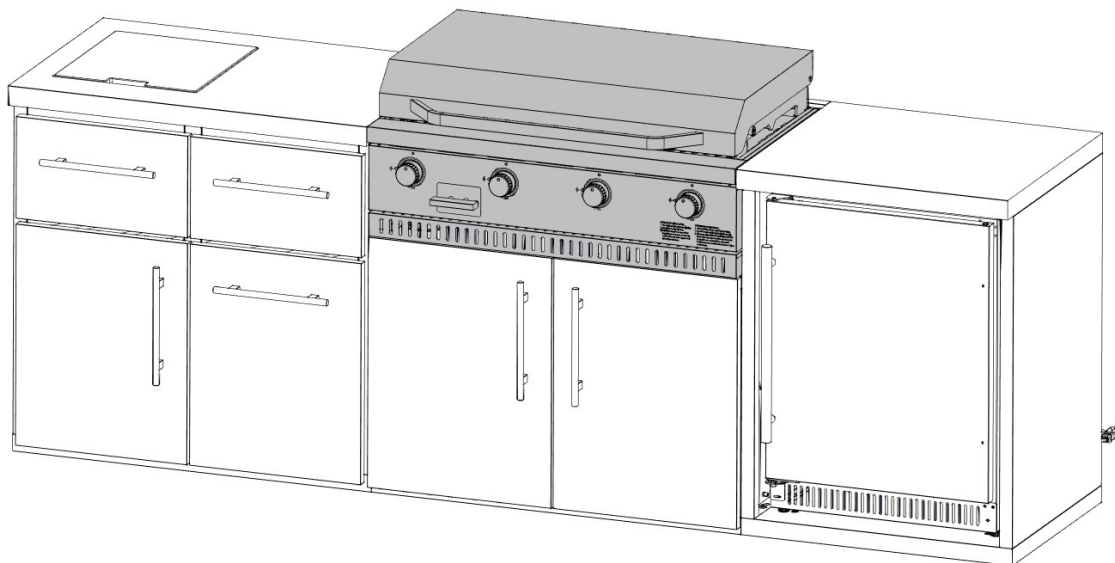

**NATURAL GAS CONVERSION KIT AVAILABLE BY CONTACTING BACKYARD DISCOVERY AT
www.backyarddiscovery.com 1-800-856-4445**

OUTDOOR KITCHEN APPLIANCE COVER INSTALLATION

- APPLIANCE COVER WILL COME PACKAGED WITH EACH RESPECTIVE APPLIANCE.
- CABINET COVER WILL HAVE CUTOUTS FOR EACH APPLIANCE LOCATION.
- INSTALL CABINET COVER OVER FULLY ASSEMBLED KITCHEN PACKAGE.
NOTE: COVER SHOULD GO ON AFTER APPLIANCES ARE INSTALLED.
- INSTALL INDIVIDUAL APPLIANCE COVERS OVER APPLIANCE, MAKING SURE FLAPS ARE ON THE OUTSIDE OF THE CABINET COVER, AND VELCRO STRIPS ARE FIRMLY CONNECTED.

