

# ASSEMBLY INSTRUCTION

## CLEAR GLASS TOP END TABLE

**A** Top Glass

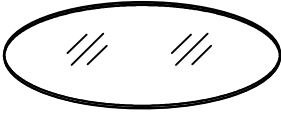

1 pc

**B** Top & Bottom Frame

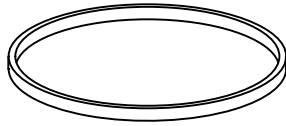

2 pcs

**C** Side Frame



3 pcs

**D** Bolt  
Ø1/4"x1/2"



12 pcs

**E** Allen Key  
M4

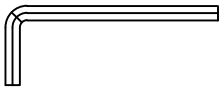

1 pc

**F** Glass Pad  
Ø8x2.5mm



6 pcs

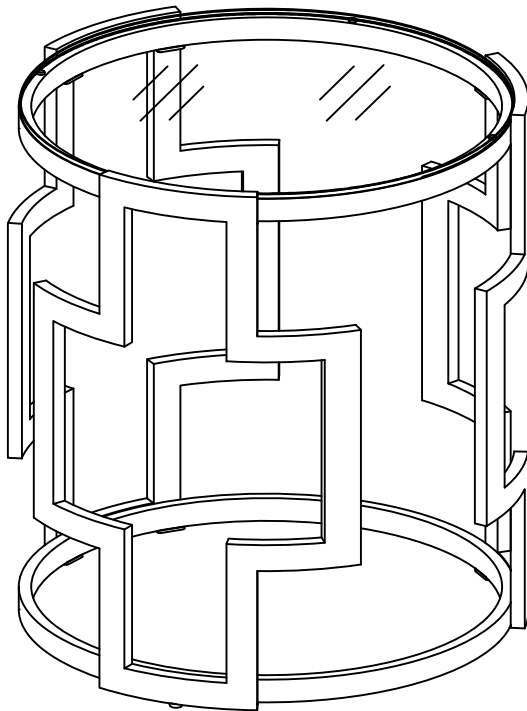

This page lists all the contents included in the box. Please take the time to identify the hardware as well as the individual components to this product. As you unpack and prepare for assembly, place the contents on a carpeted or padded area to protect them from damage.

\*\*\*Do not tighten screws & bolts until the entire unit is completely assembled.

- 1** Attach 2pcs Side Frame (C) to 1pc of Top & Bottom Frame (B) using Bolt (D) by Allen Key (E) as below shown.

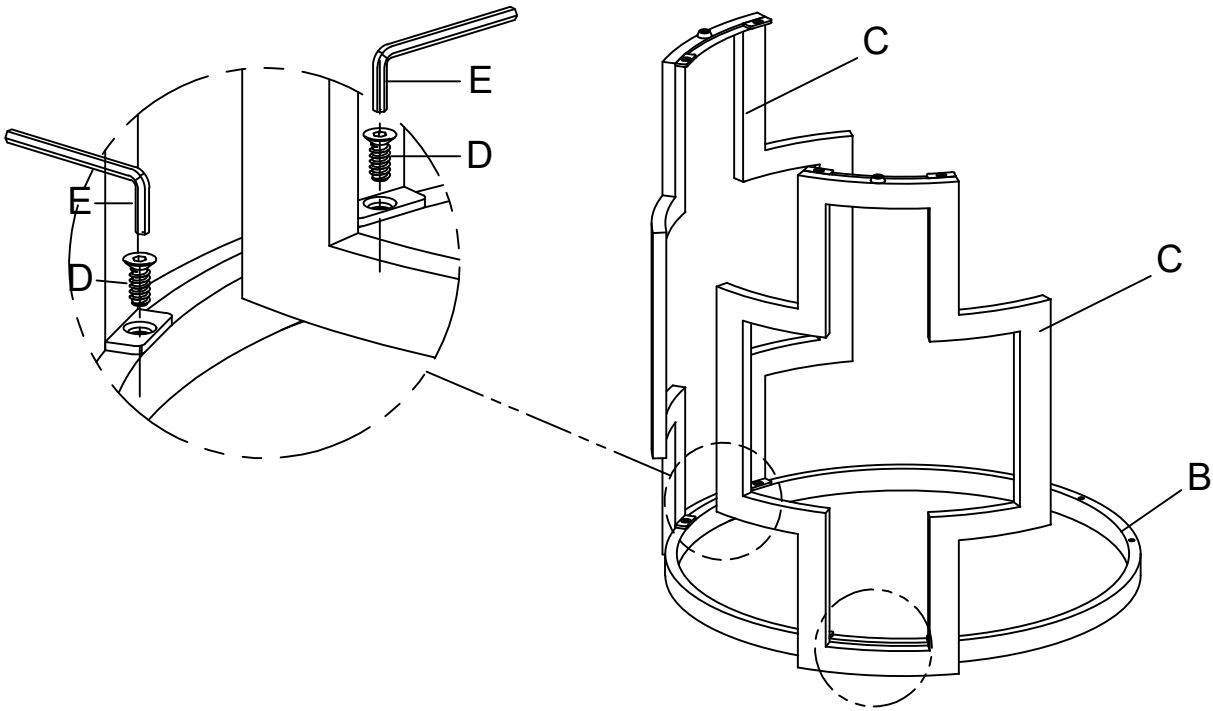

- 2** Attach pre-assembled Side Frame (C) to the rest 1pc of Top & Bottom Frame (B) using Bolt (D) by Allen Key (E) as below shown.

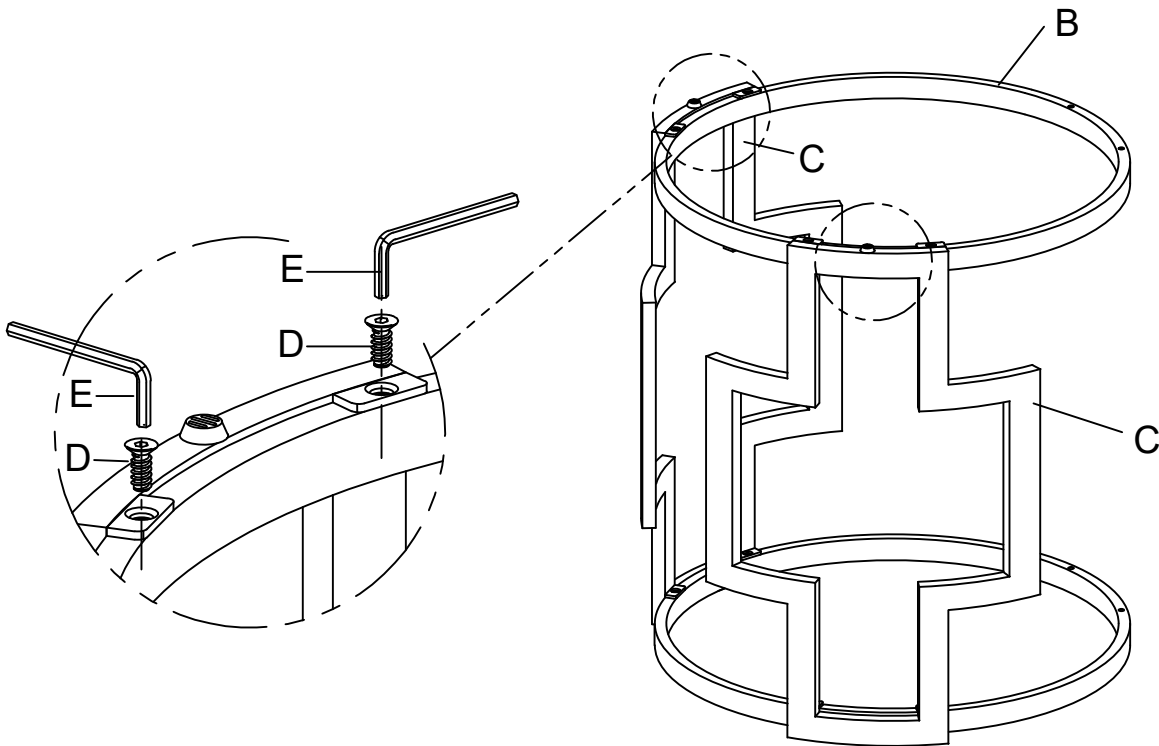

- 3** Attached the rest 1pc of Side Frame (C) to Top & Bottom Frame (B) using Bolt (D) by Allen Key (E) as below shown.

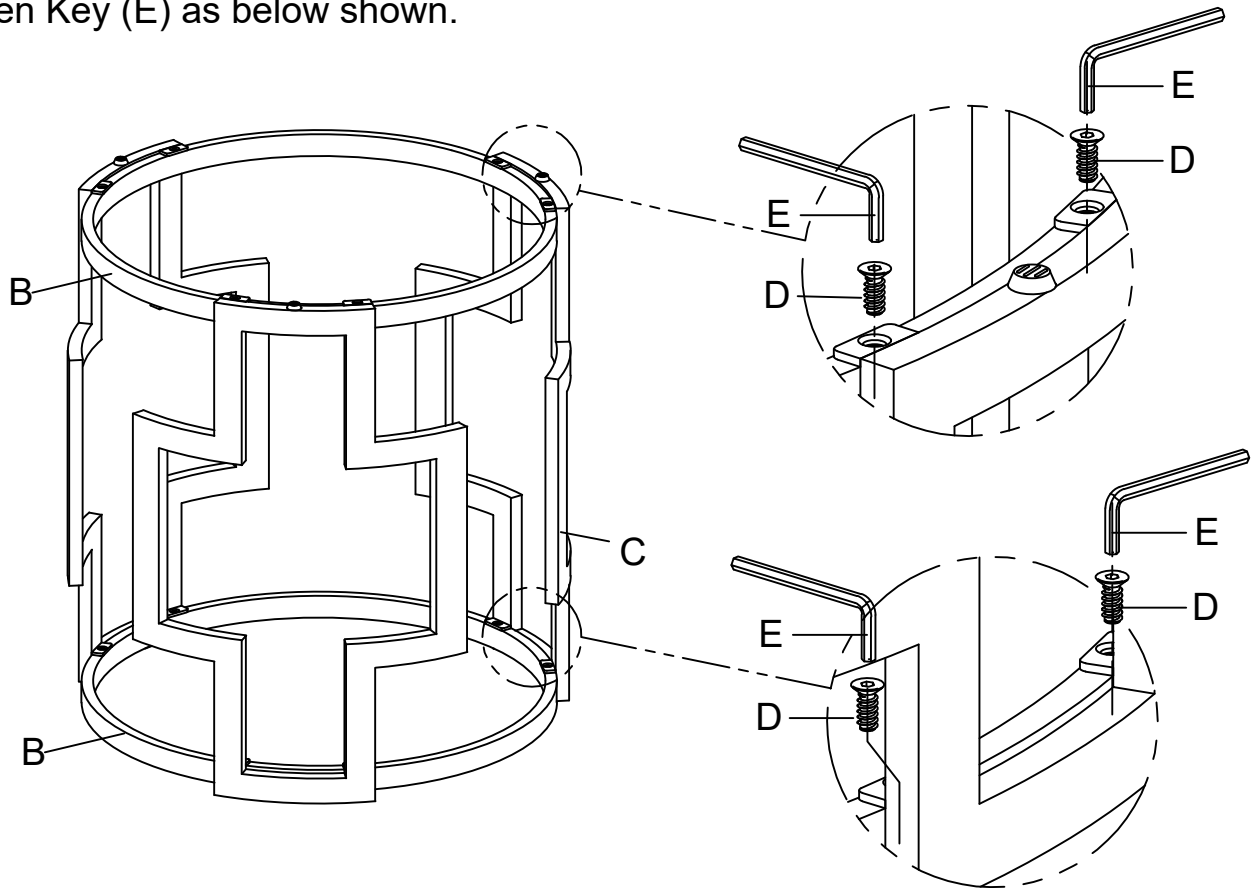

- 4** Turn over the table, put Glass Pad (F) to Top Frame (B), then put Top Glass (A) onto Glass Pad (F) as below shown.

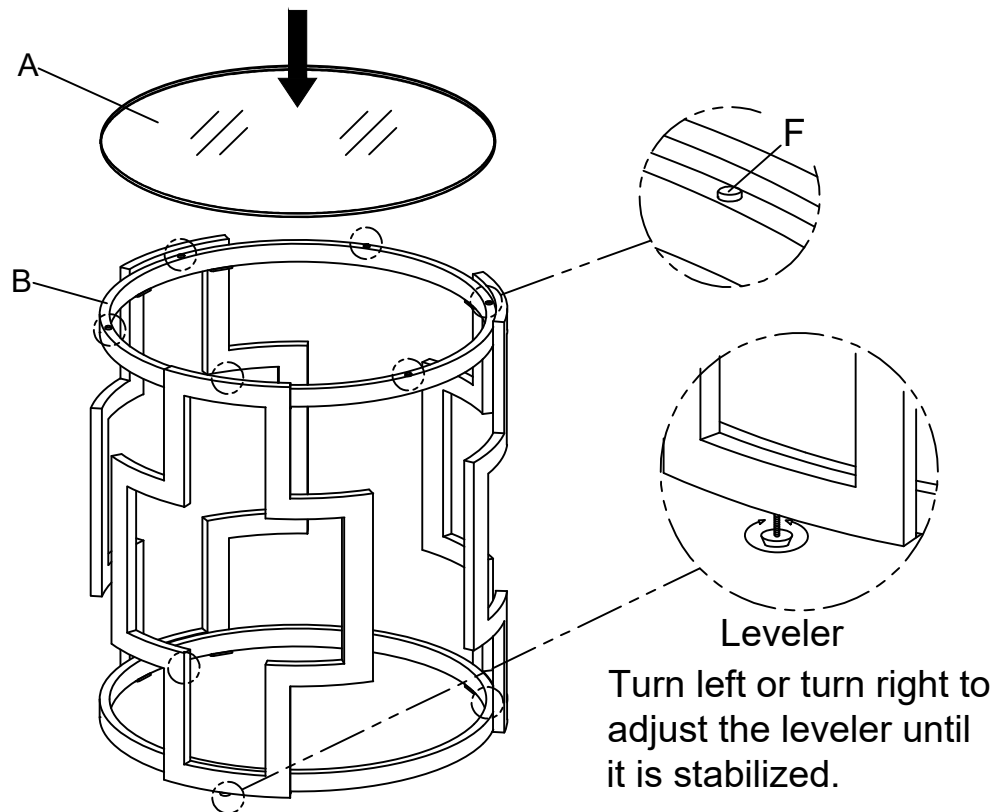

### Cleaning & Care

Treat surface with care. Surface is resistant to scratches but is not scratch resistant. Clean surfaces with a dry or damp soft cloth. Do not use abrasive cleaners. Hardware may loosen over time. Periodically check that all connections are tight.

# ASSEMBLY INSTRUCTION

## CLEAR GLASS TOP COFFEE TABLE

**A** Top Glass

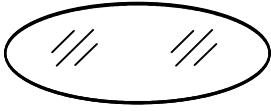

1 pc

**B** Top & Bottom Frame

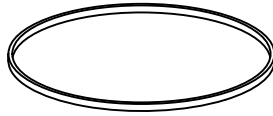

2 pcs

**C** Side Frame

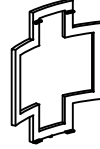

4 pcs

**D** Bolt  
Ø1/4"x1/2"



16 pcs

**E** Allen Key  
M4

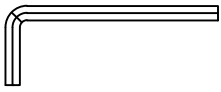

1 pc

**F** Glass Pad  
Ø8x2.5mm



8 pcs

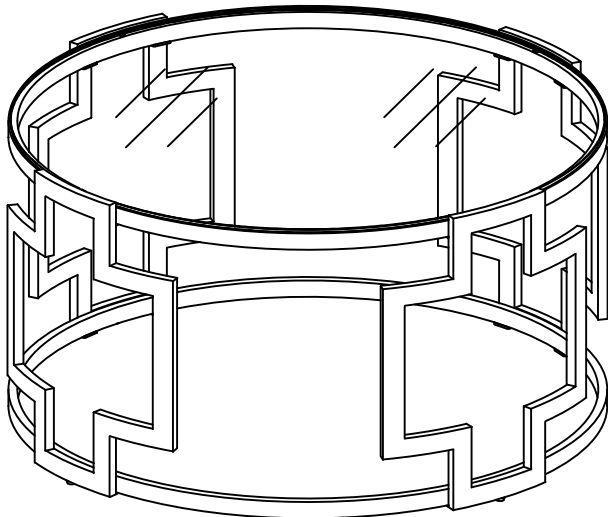

This page lists all the contents included in the box. Please take the time to identify the hardware as well as the individual components to this product. As you unpack and prepare for assembly, place the contents on a carpeted or padded area to protect them from damage.

\*\*\*Do not tighten screws & bolts until the entire unit is completely assembled.

- 1** Attach 3pcs Side Frame (C) to 1pc of Top & Bottom Frame (B) using Bolt (D) by Allen Key (E) as below shown.

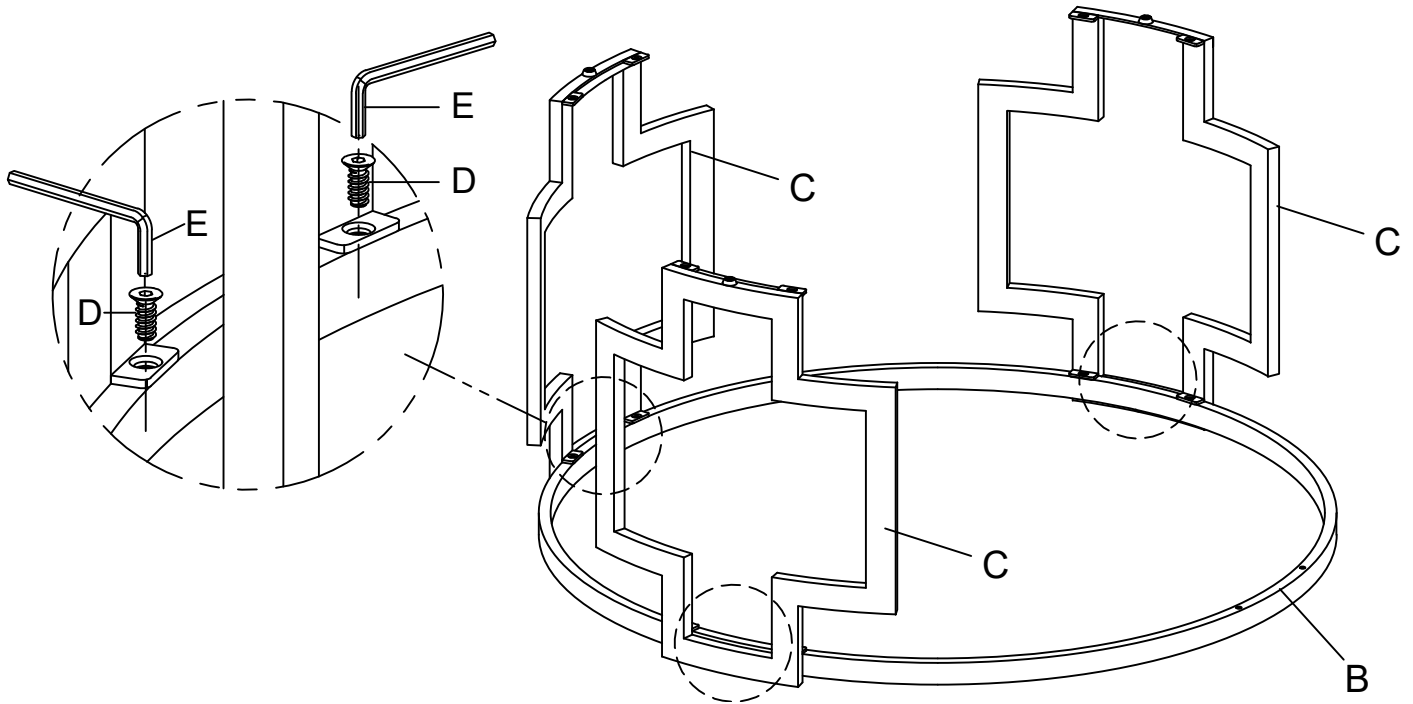

- 2** Attach pre-assembled Side Frame (C) to the rest 1pc of Top & Bottom Frame (B) using Bolt (D) by Allen Key (E) as below shown.

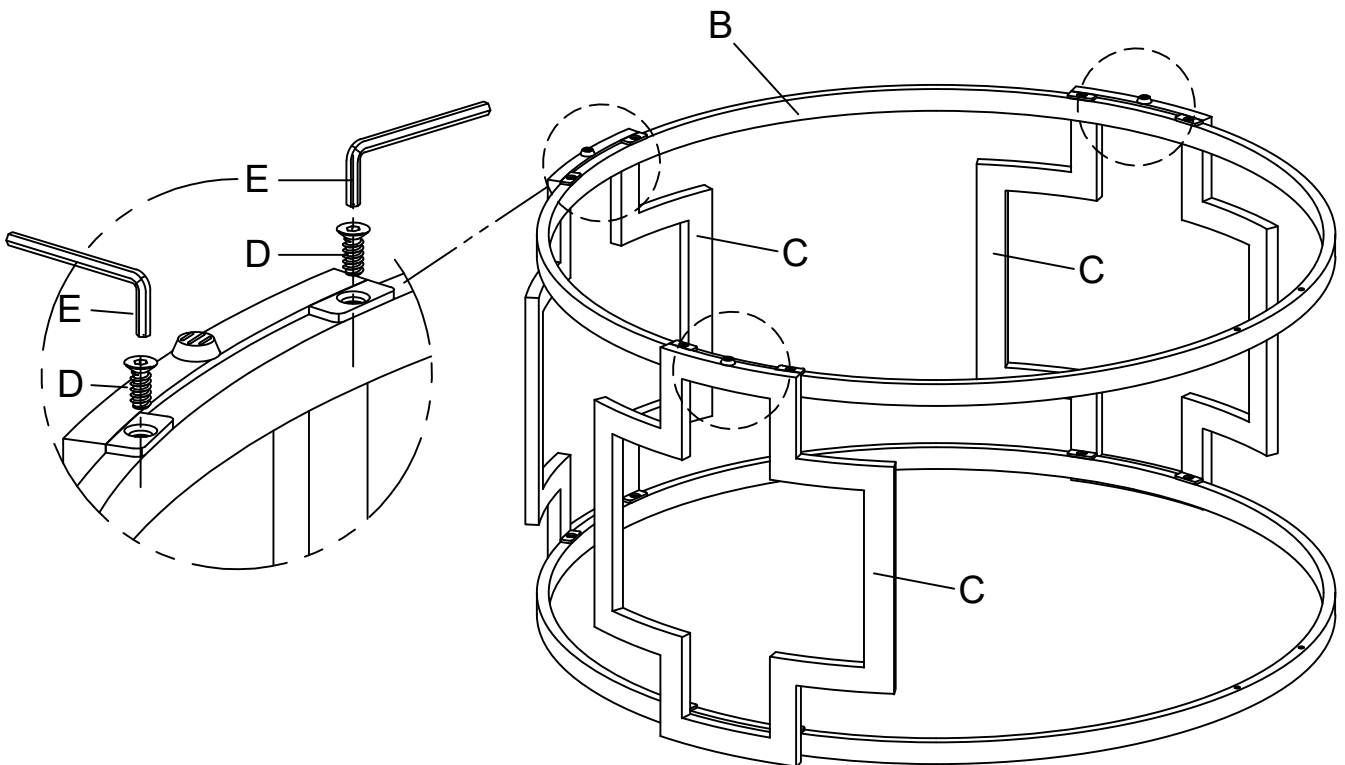

**3** Attached the rest 1pc of Side Frame (C) to Top & Bottom Frame (B) using Bolt (D) by Allen Key (E) as below shown.

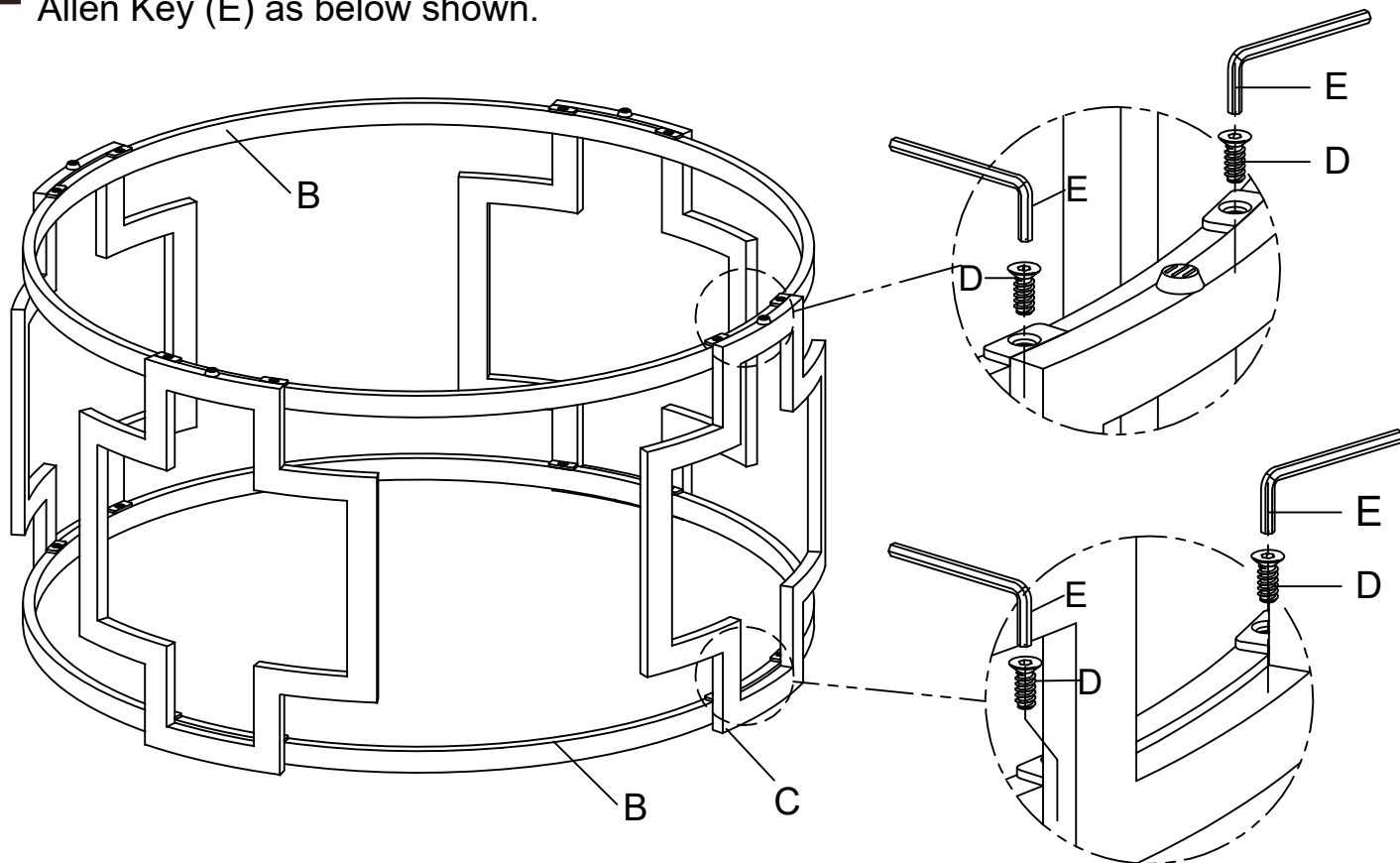

**4** Turn over the table, put Glass Pad (F) to Top Frame (B), then put Top Glass (A) onto Glass Pad (F) as below shown.

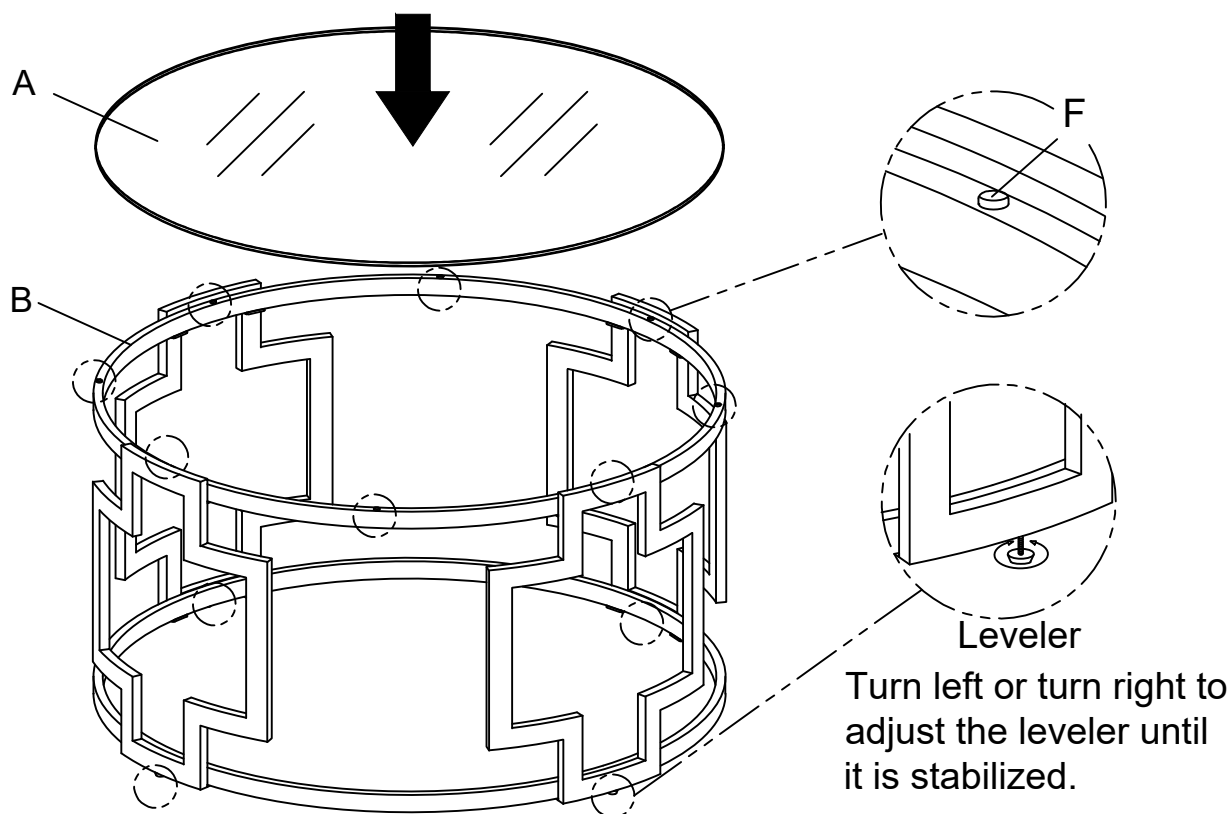

### Cleaning & Care

Treat surface with care. Surface is resistant to scratches but is not scratch resistant. Clean surfaces with a dry or damp soft cloth. Do not use abrasive cleaners. Hardware may loosen over time. Periodically check that all connections are tight.