

Product Specifications

10.7 Gallon Screw Top ST3 Cover

Note: *UN Solids rated to Y54.0/S

Multiple Uses

Dry Products

Product Codes

Cover: **8900 Series**

Description: 7.7 / 10.7 Gallon Screw Top Cover

Features

Gauge: 100 mil

Tare weights: Cover: 1.32 lbs. / 600 gr.

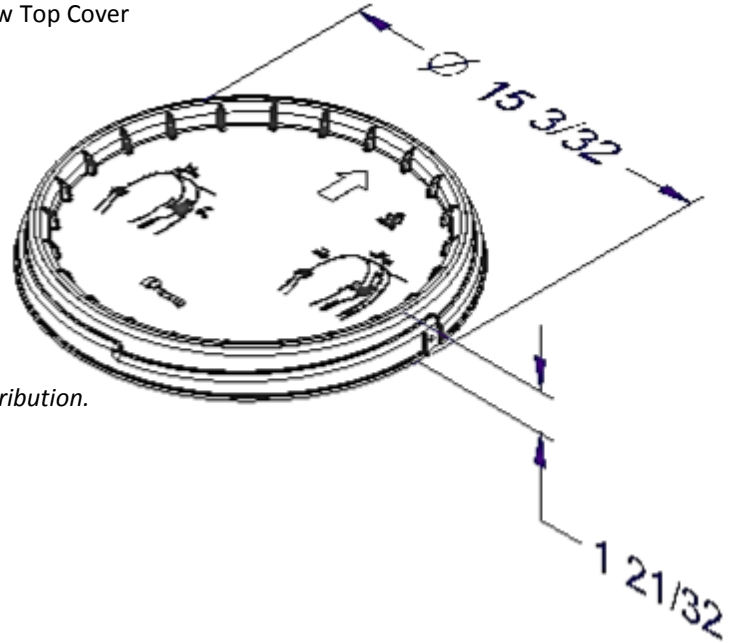

Note: *Ratings will be reduced with uneven load distribution.

Colors

Standard: White, Black and Natural

Custom: Available at manufacturer's discretion

Shipping Data

Qty. per pallet/carton:	594*
Gross Weight (lbs/kgs.)**:	784/355.6
Length (in./cm.):	47/119.4
Width (in./cm.):	47/119.4
Height (in./cm.):	87/220.9
Approximate truckload quantity of 2,592 pails and covers***	

Covers

Materials

FDA approved materials

Resin:

Cover: High-Density Polyethylene (HDPE)

MSDS Sheets available upon request

DISTRIBUTED BY:



REF NO.:

DWG10182

DESCRIPTION:

10.7 Gallon HDPE Screw Top Cover, UN Rated

DISCLAIMER

THIS INFORMATION IS PROVIDED AS A GENERAL GUIDE, INCLUDING DIMENSIONS. IT IS THE CUSTOMER'S RESPONSIBILITY TO SELECT THE PROPER CONTAINER FOR PRODUCT AND APPLICATION COMPATIBILITY.