

Item: BR6DRLEEDR-T

Assembly Instructions



Please visit our website for the most current instructions, assembly tips, to report damage or request parts. www.walkeredison.com

Revised 07/2024-V2

General assembly guidelines

- I. Ensure that all parts and hardware are available before beginning assembly.
- II. Follow each step carefully to ensure the proper assembly of this product.
- III. Two people are recommended for ease in the assembly of this product.
- IV. The three main types of hardware used to assemble this product are wood dowels, screws and bolts.
- V. A phillips head screwdriver, hammer and tape measure is required for the assembly of this product.

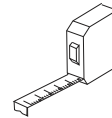
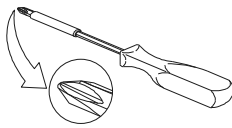
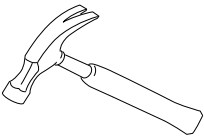

- VI. Power tools should not be used to assemble this product.

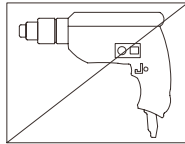

VII. Maintenance Guide

To maintain long term performance and easy gliding of your solid wood drawers, we recommend applying wax to the wooden guide rails.

1. Bee's wax is recommended or Paraffin wax from a standard candle can be used.
2. Apply the wax by rubbing it on the wooden guide rails where there is wood-on-wood contact when opening and closing the drawer. (Wax should be room temperature, do not melt the wax onto the wood)
3. Wax should be applied every few months for the first year and then only when needed after that to keep the drawers sliding smoothly.

Parts List

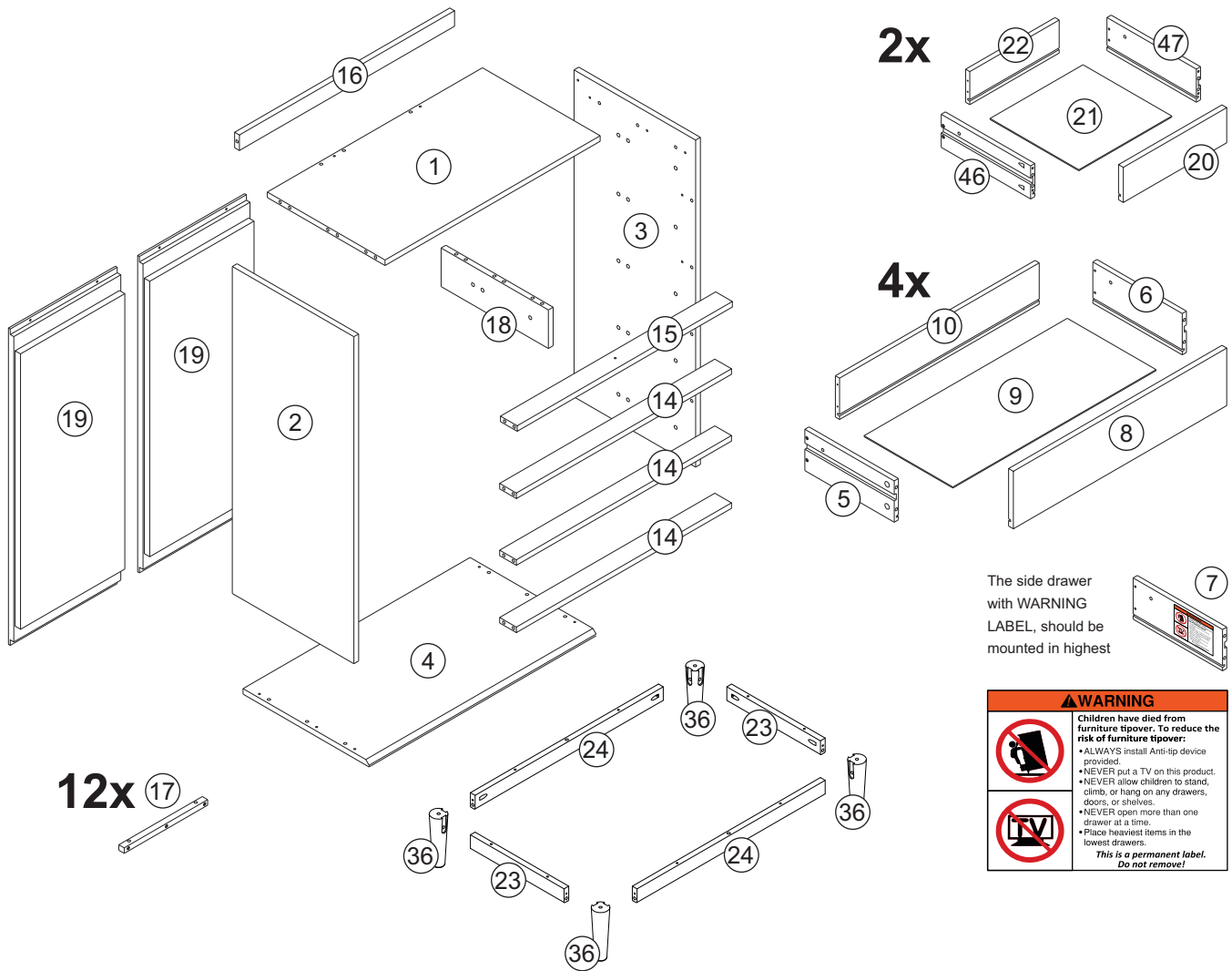

The side drawer with WARNING LABEL, should be mounted in highest

WARNING

Children have died from furniture tipover. To reduce the risk of furniture tipover:









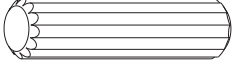
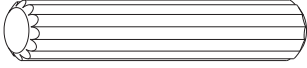
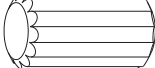

- ALWAYS install Anti-tip device provided.
- NEVER put a TV on this product.
- NEVER allow children to stand, climb, or hang on any drawers, doors, or shelves.
- NEVER open more than one drawer at a time.
- Place heaviest items in the lowest drawers.

This is a permanent label. Do not remove!

Part #	Description	Qty
1	Top panel	01 pc
2	Left side panel	01 pc
3	Right side panel	01 pc
4	Base	01 pc
5	Left drawer side	04 pcs
6	Right drawer side	03 pcs
7	Right drawer side (warning)	01 pc
8	Drawer front	04 pcs
9	Drawer bottom	04 pcs
10	Drawer back	04 pcs
14	Front rail	03 pcs
15	Upper front rail	01 pc

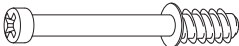
Part #	Description	Qty
16	Top rail	01 pc
17	Wood slider	12 pcs
18	Small divison	01 pc
19	Back panel	02 pcs
20	Small drawer front	02 pcs
21	Small drawer bottom	02 pcs
22	Small drawer back	02 pcs
23	Bottom side rail	02 pcs
24	Bottom front rail	02 pcs
36	Foot	04 pcs
46	Small left drawer side	02 pcs
47	Small right drawer side	02 pcs

Hardware List

A		Ø8*30mm	Wood dowel	60 pcs
B		Ø8*40mm	Wood dowel	12 pcs
C		Ø10*20mm	Wood dowel	36 pcs
D		Ø3,0*12mm	Screw	20 pcs
E		Ø3,5*20mm	Screw	09 pcs
F		Ø4,0*25mm	Screw	36 pcs
G		Ø3,5*30mm	Screw	35 pcs
H		Ø4,0*40mm	Screw	23 pcs
J		-	Handle	10 pcs
K		Ø8,0*31mm	Cam bolt	35 pcs
L		Ø15*11mm	Cam lock	35 pcs
M		-	Ø6mm	01 pc
N		-	Washer	02 pcs
O		-	Wall anchor	01 pc

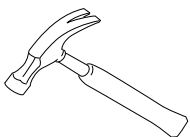

Hammer
recommended
for assembly
(not included)

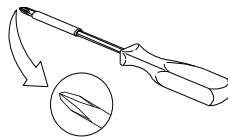

Phillips head
screwdriver required
for assembly
(not included)

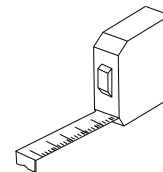

Tape measure
required for
assembly
(not included)

*The hardware quantities listed above are required for proper assembly.
Some extra hardware may also have been included.*

Step 1

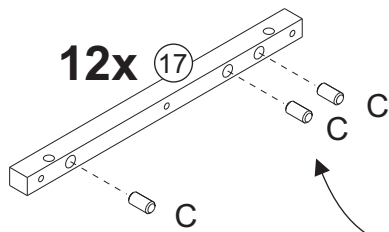

Attention to the
dowel size:
Ø10*20mm

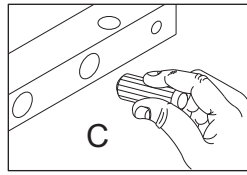
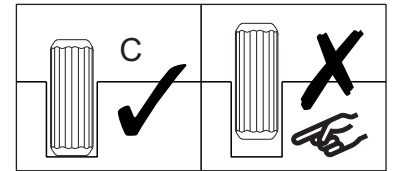

Insert wood dowel (C) into part 17.

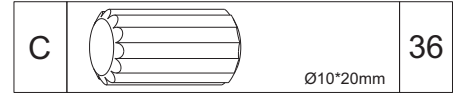

Step 2

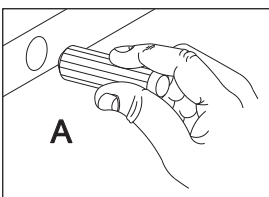
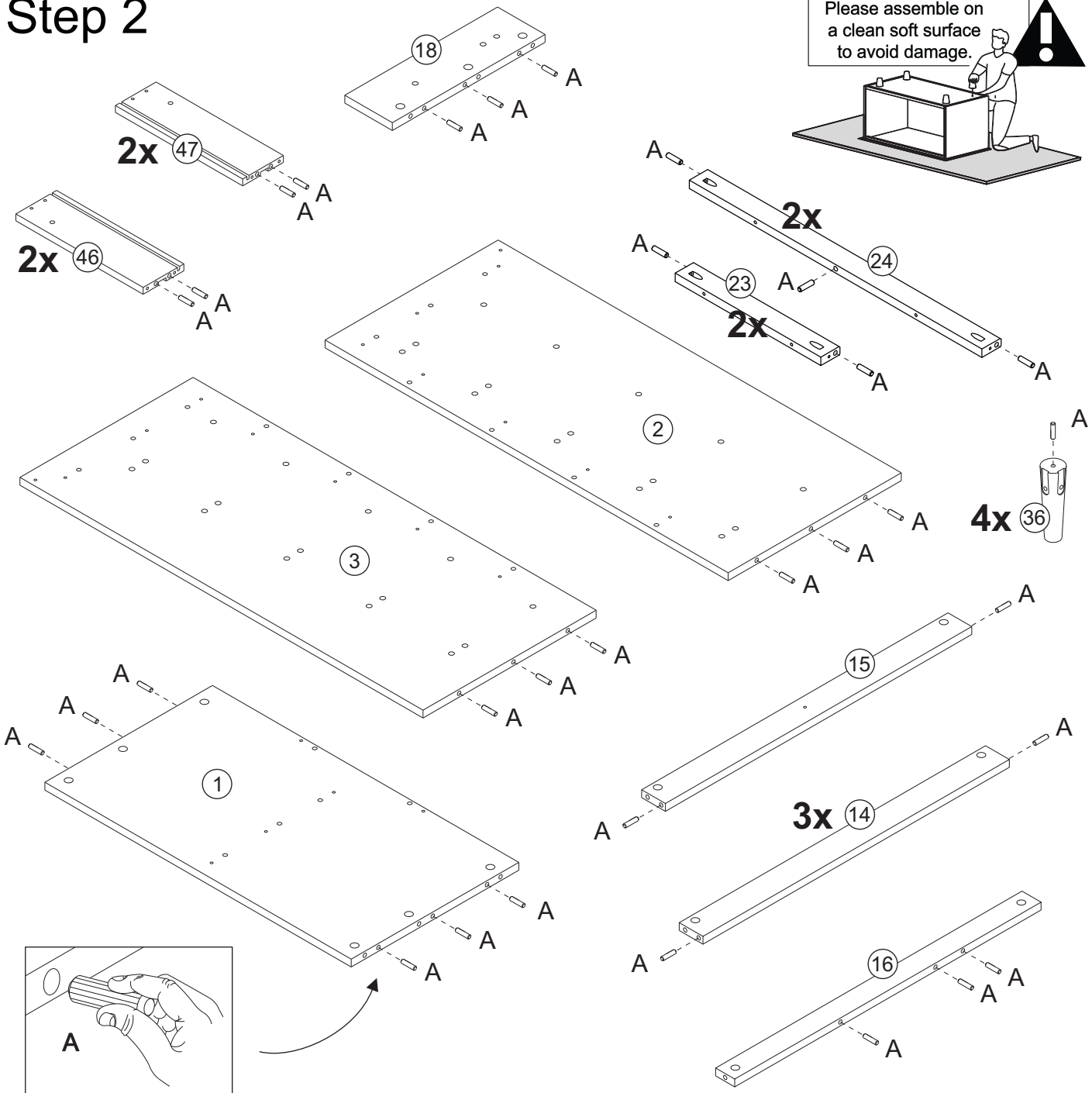

Insert wood dowel (A) into parts 1, 2, 3, 14, 15, 16, 18, 23, 24, 36, 46 and 47.

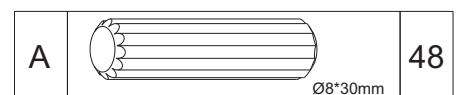

Step 3

1 - Ensure cam bolt is installed straight and not at an angle.
2 - Tighten cam bolt until shoulder on cam bolt is flush. Do not over-tighten.

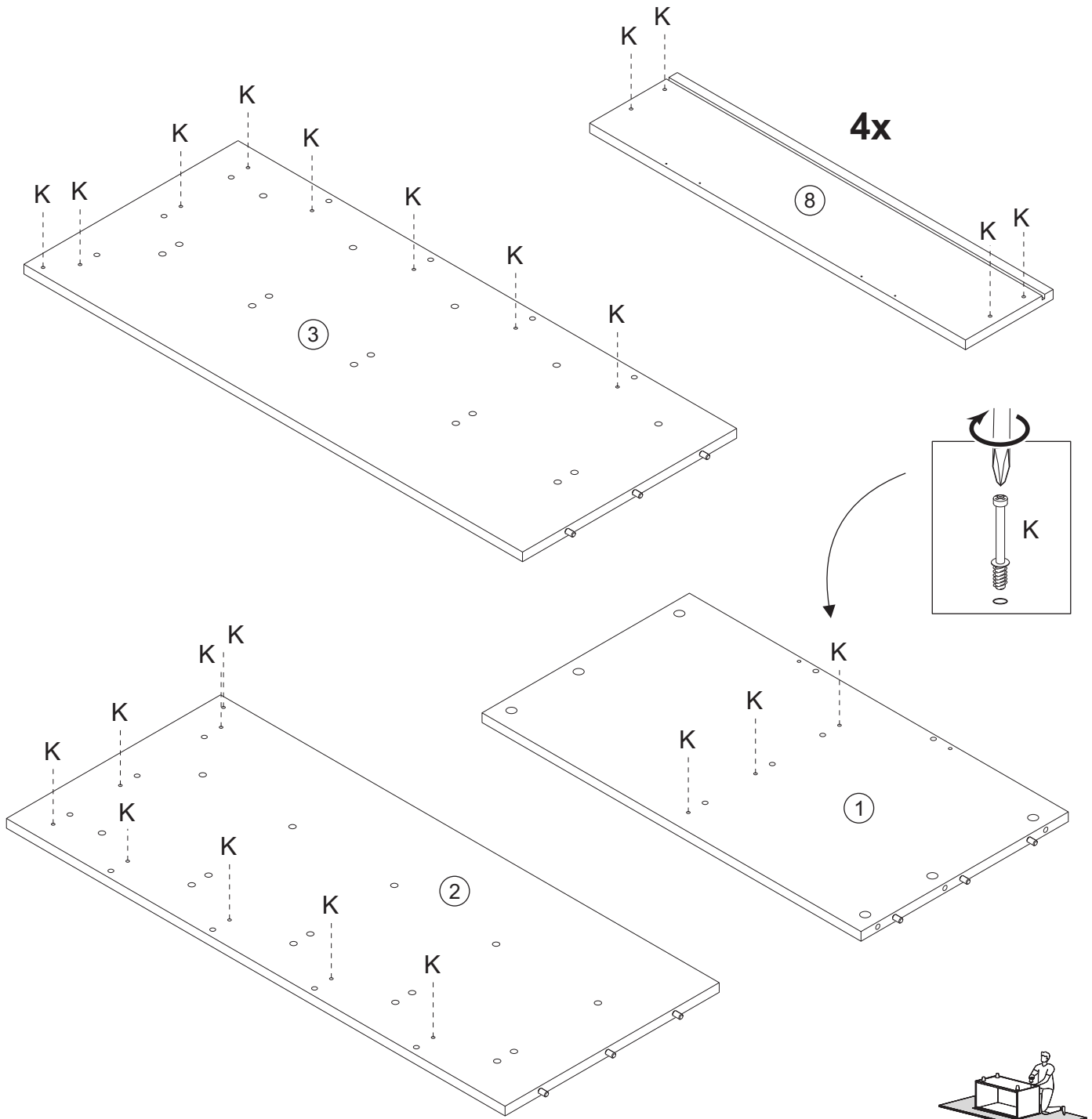
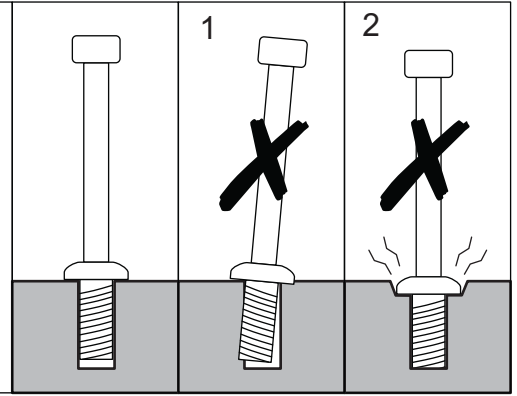

Screw cam bolts (K) into parts 1, 2, 3 and 8 with a phillips head screwdriver.

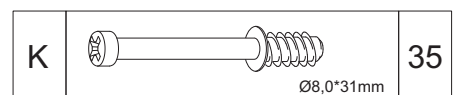

Step 4

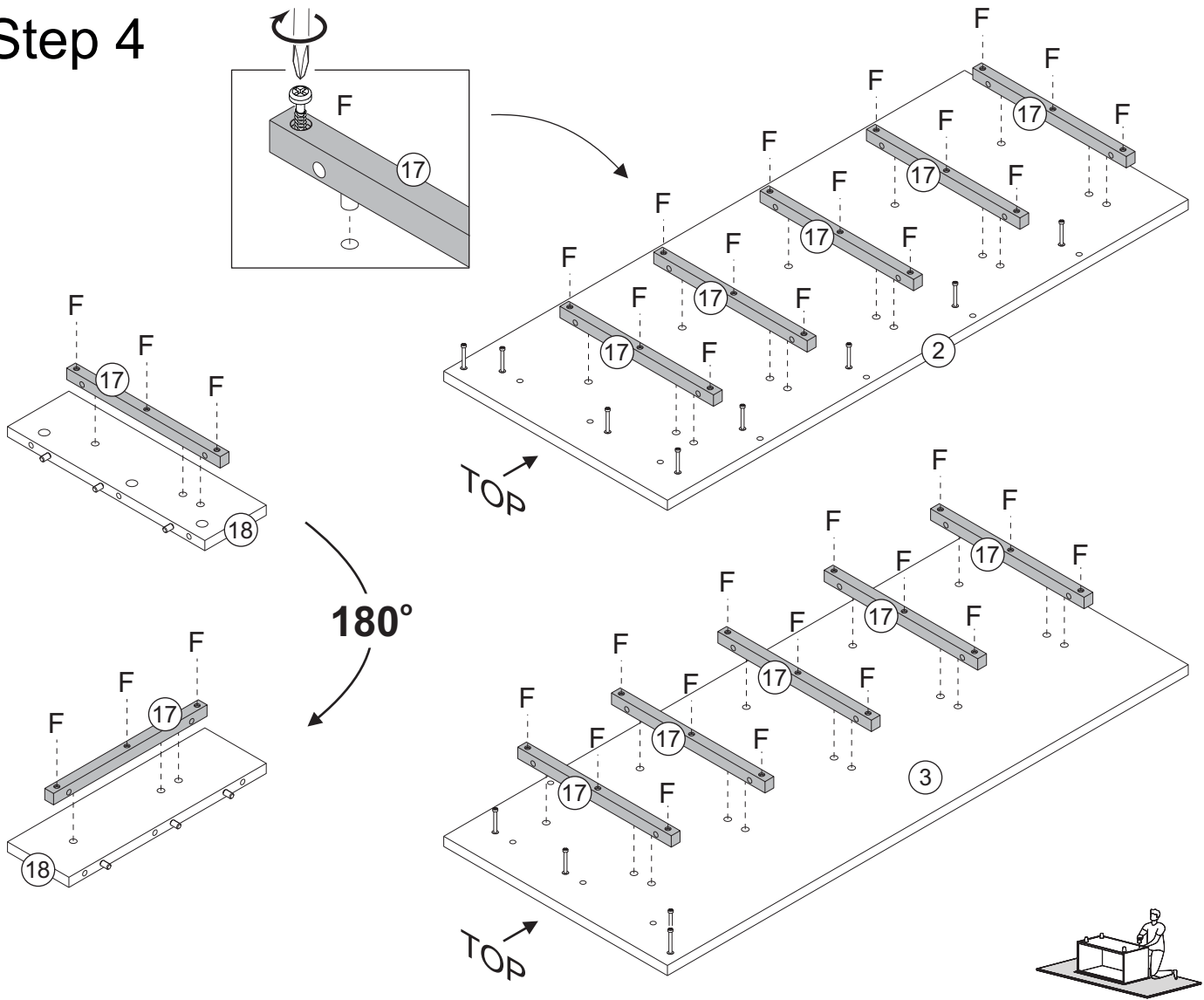

Secure parts 17 to parts 2, 3 and 18 with screw (F) and phillips head screwdriver.

F		36
		Ø4,0*25mm

Step 5

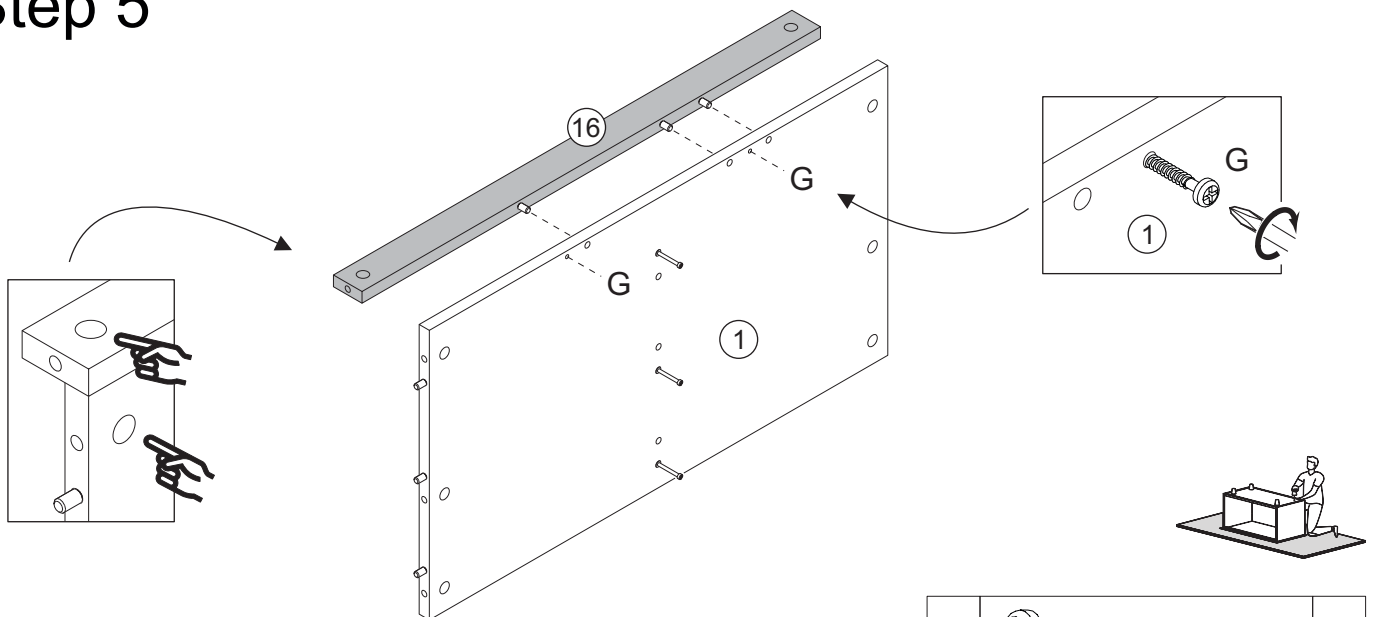

Secure part 16 to part 1 with screw (G) and phillips head screwdriver.

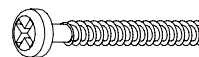
G		02
		Ø3,5*30mm

Step 6

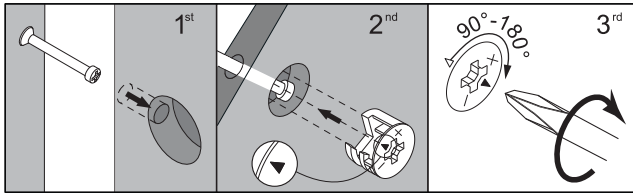

Align the opening in cam lock to the cam bolt and press into opening. Using a screwdriver, rotate the cam lock until it engages with the cam bolt and locks in place (anywhere between 90-180 degrees). Do not over-tighten the cam lock. Doing so may result in damaged or broken parts.

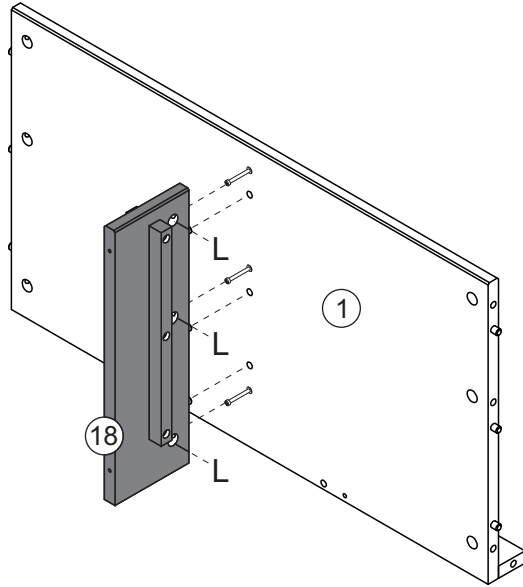

Secure part 18 to part 1. Insert cam locks (L) into part 18, and tighten with a phillips head screwdriver.

L		03
Ø15*11mm		

Step 7

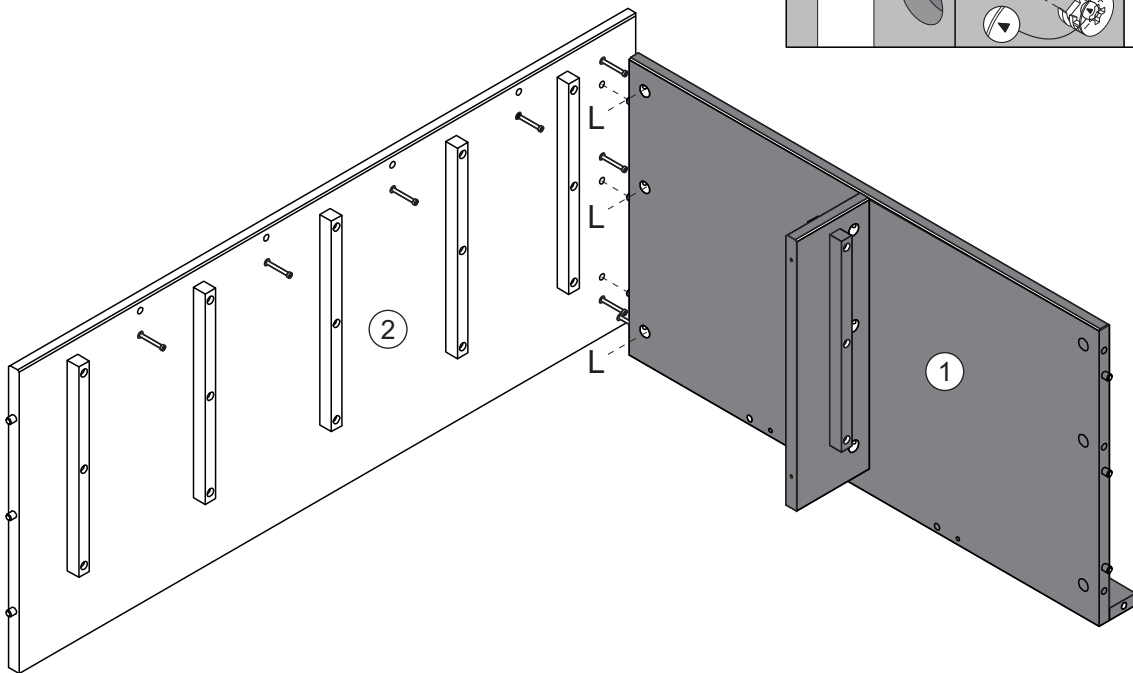
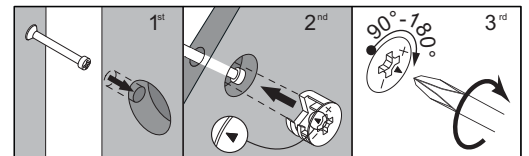

Secure parts 1 to part 2. Insert cam locks (L) into part 1 and tighten with a phillips head screwdriver.

L		03
Ø15*11mm		

Step 8

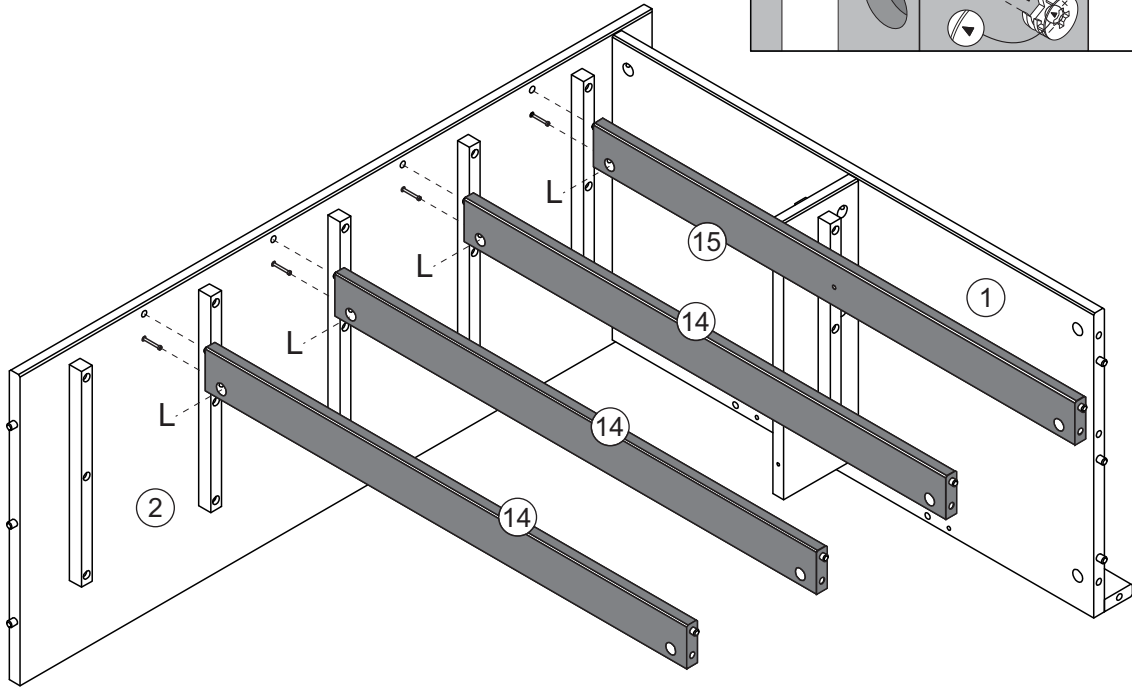
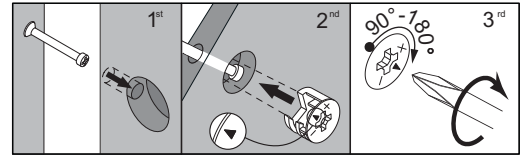

Secure parts 14 and 15 to part 2. Insert cam locks (L) into parts 14 and 15, and tighten with a phillips head screwdriver.



Step 9

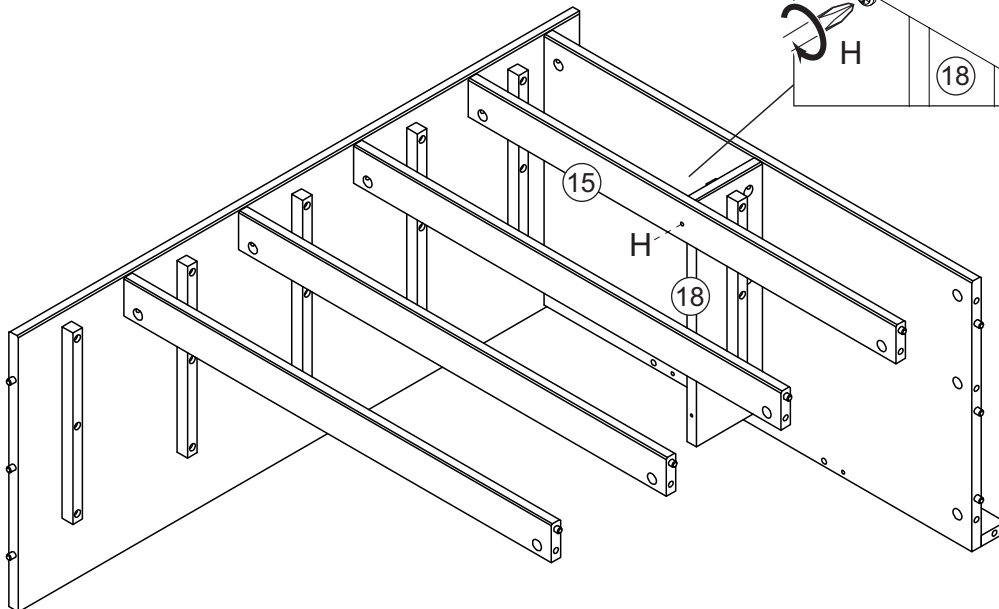
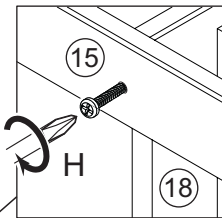

Secure part 15 to part 18 with screw (H) and phillips head screwdriver.

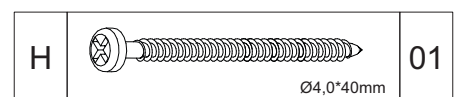

Step 10

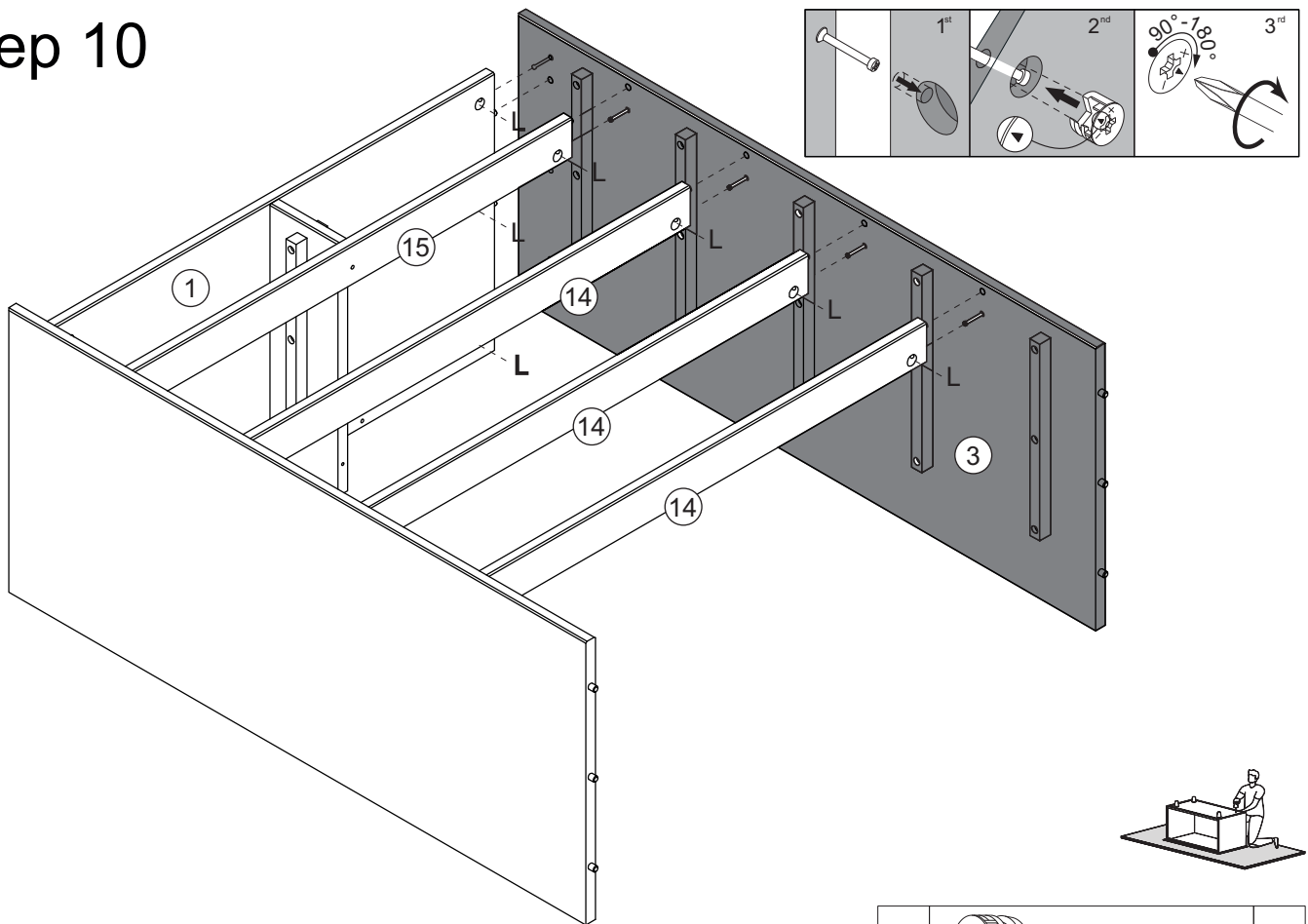

Secure parts 1, 14 and 15 to part 3. Insert cam locks (L) into parts 1, 14, and 15, and tighten with a phillips head screwdriver.

L		07
Ø15*11mm		

Step 11

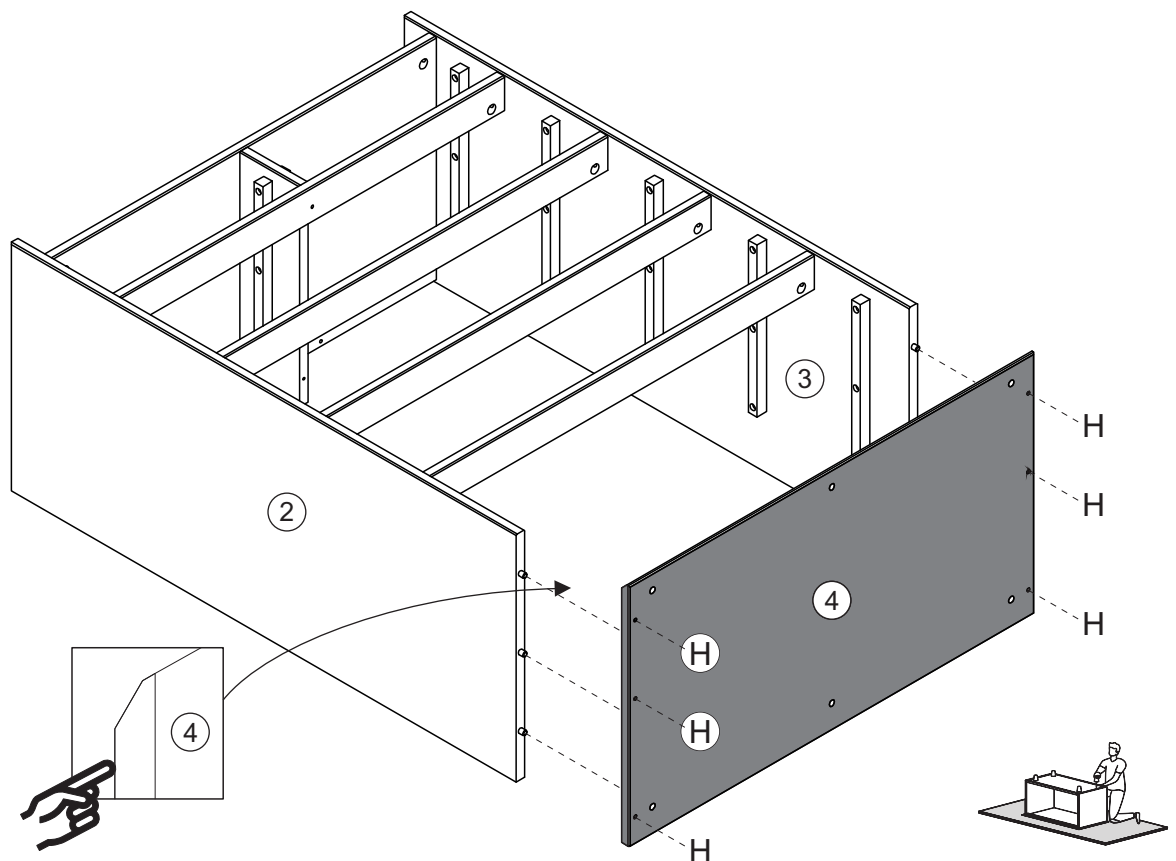

Secure part 4 to parts 2 and 3 with screw (H) and phillips head screwdriver.

H		06
Ø4,0*40mm		

Step 12

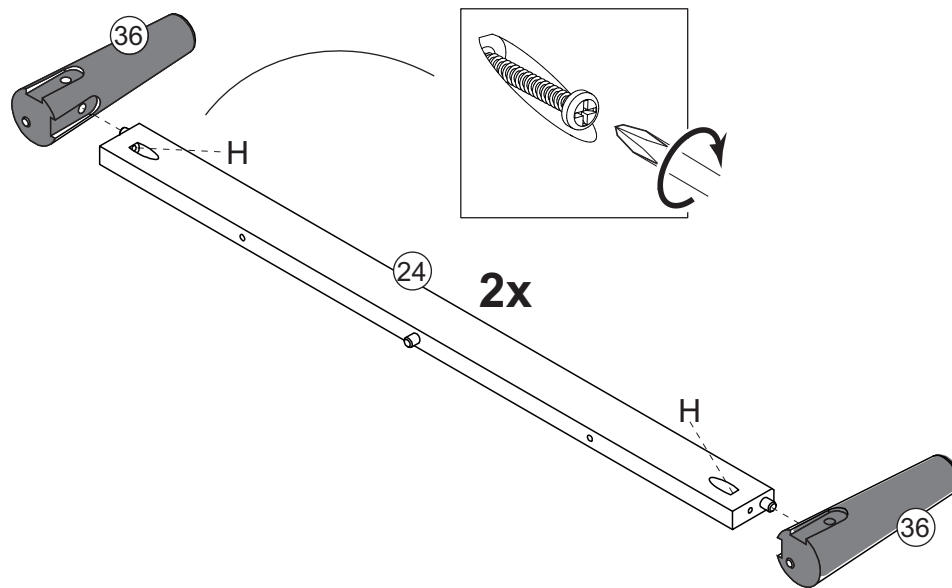

Secure part 24 to parts 36, with screw (H) and phillips head screwdriver.

H		04
		Ø4,0*40mm

Step 13

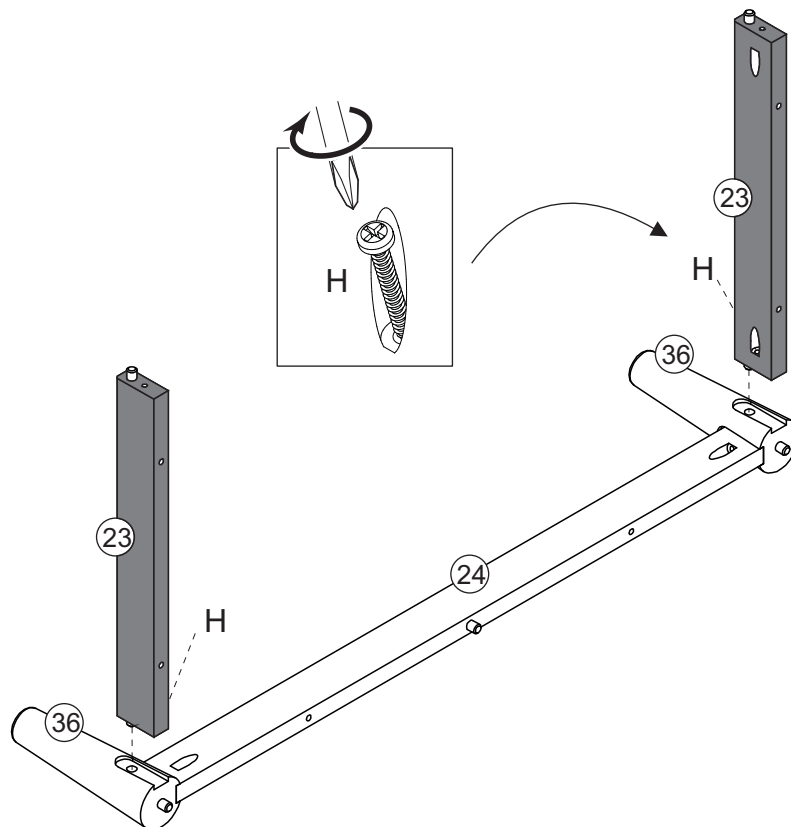

Secure parts 23 to parts 36, with screw (H) and phillips head screwdriver.

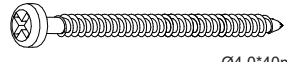
H		02
		Ø4,0*40mm

Step 14

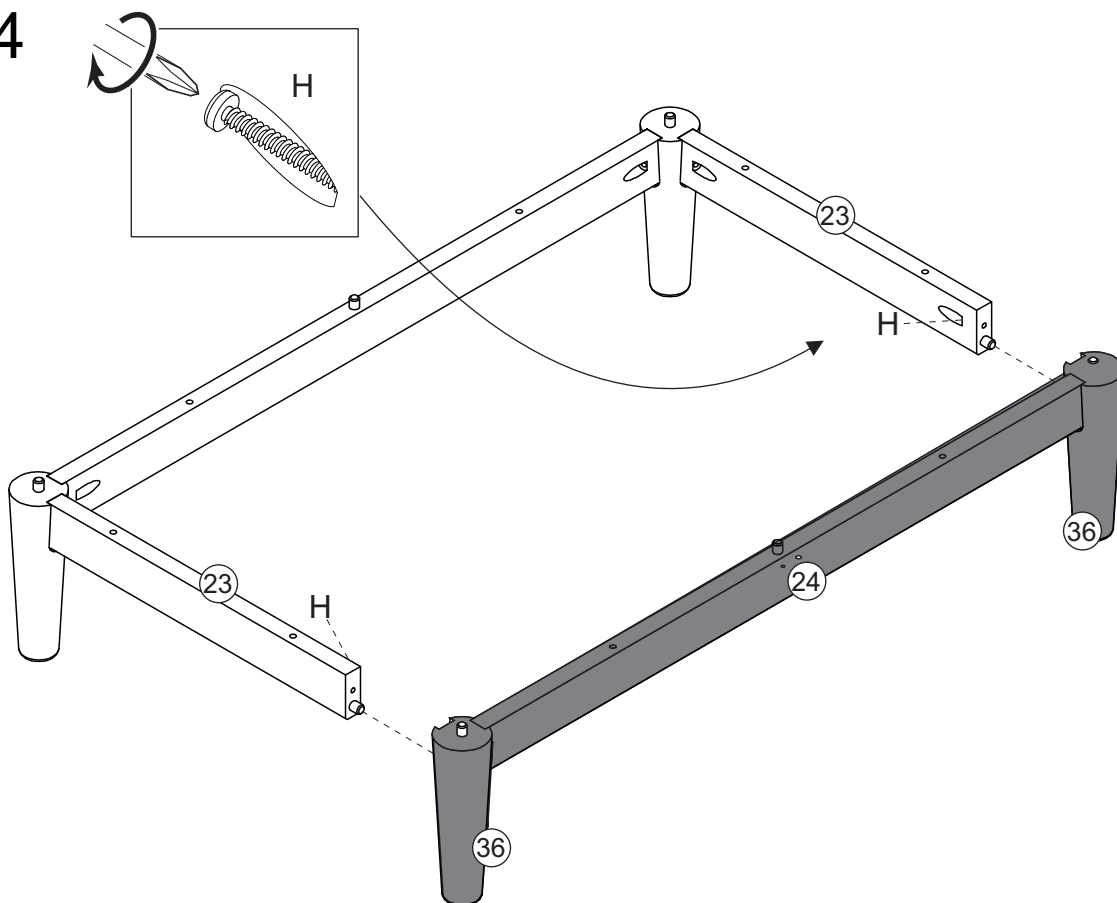

Secure parts 23 to parts 36, with screw (H) and phillips head screwdriver.

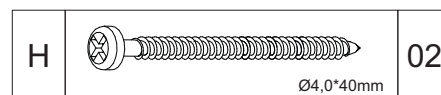

Step 15

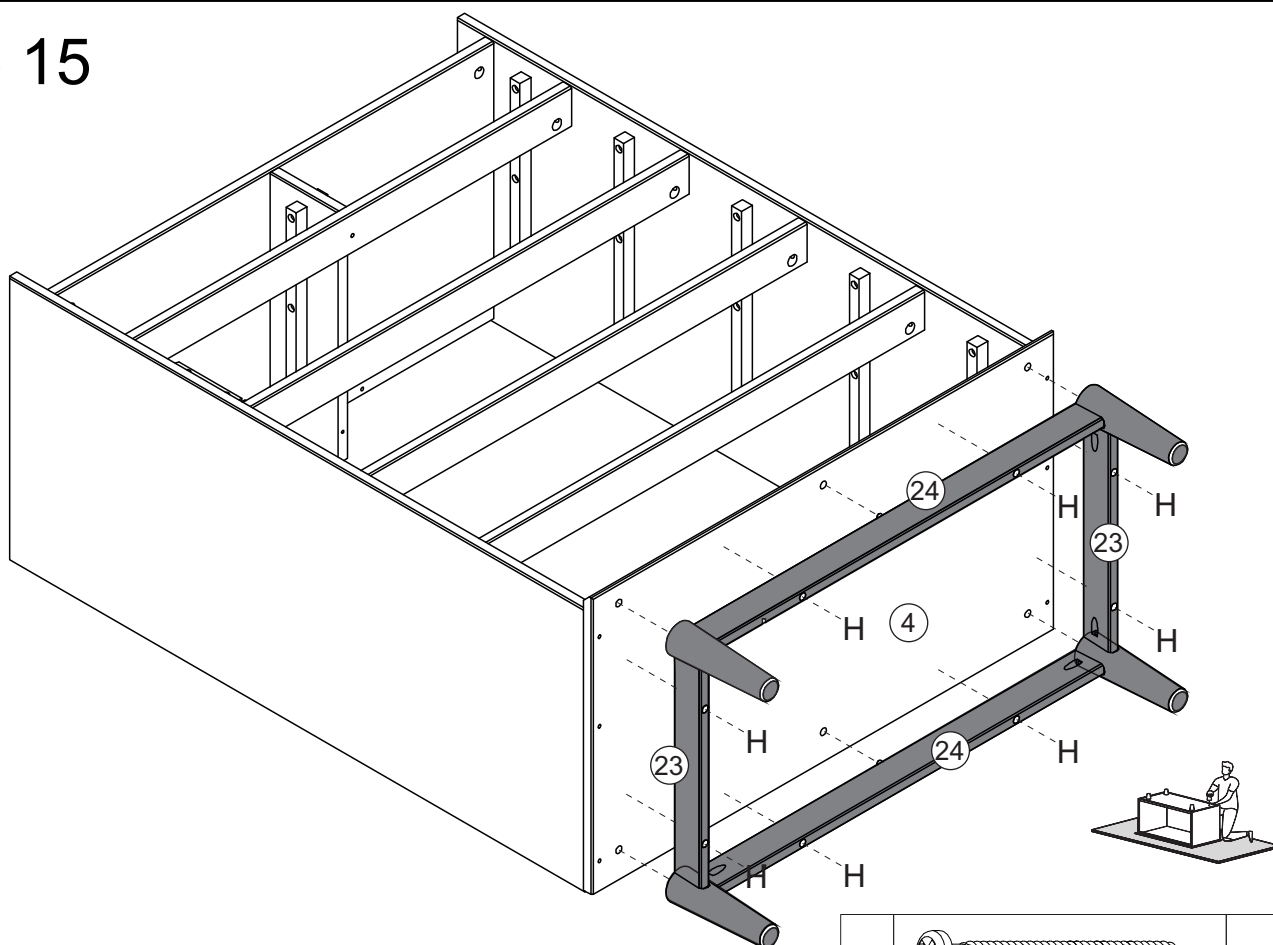

Secure parts 23 and 24 to part 4 with screw (H) and phillips head screwdriver.

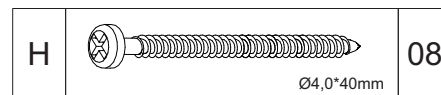

Step 16

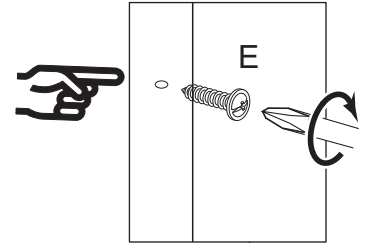
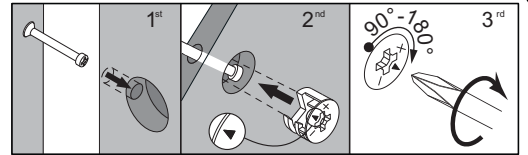
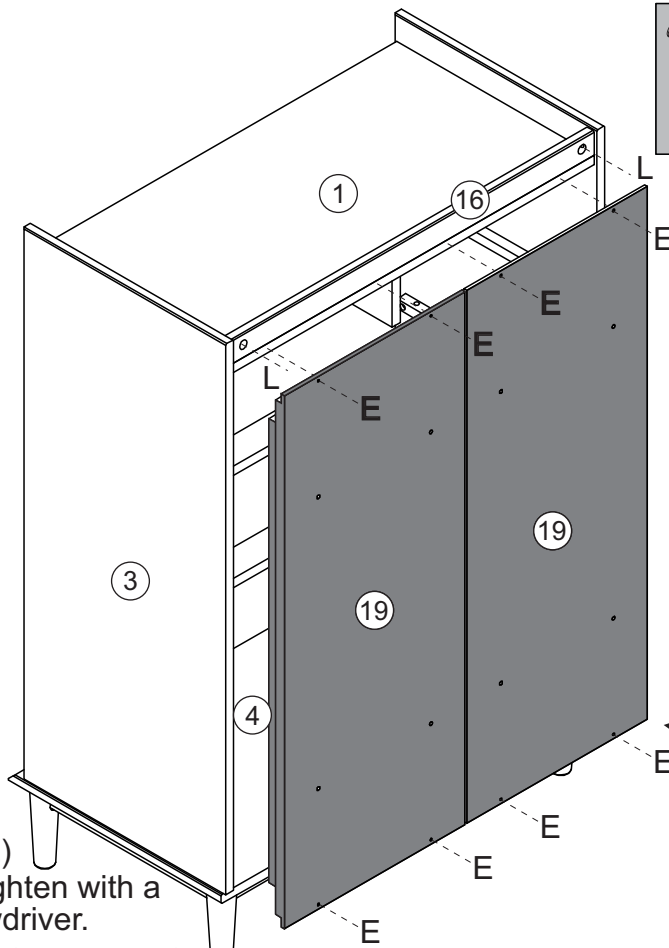

Insert cam locks (L) into part 16, and tighten with a phillips head screwdriver.

Secure back panel 19 to parts 1 and 4 as shown above with screw (E) and phillips head screwdriver.

E		08
		Ø3,5*20mm
L		02
		Ø15*11mm

Step 17

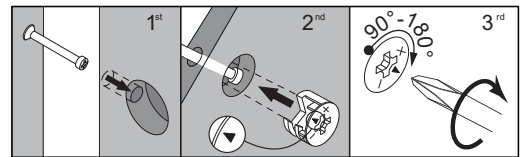
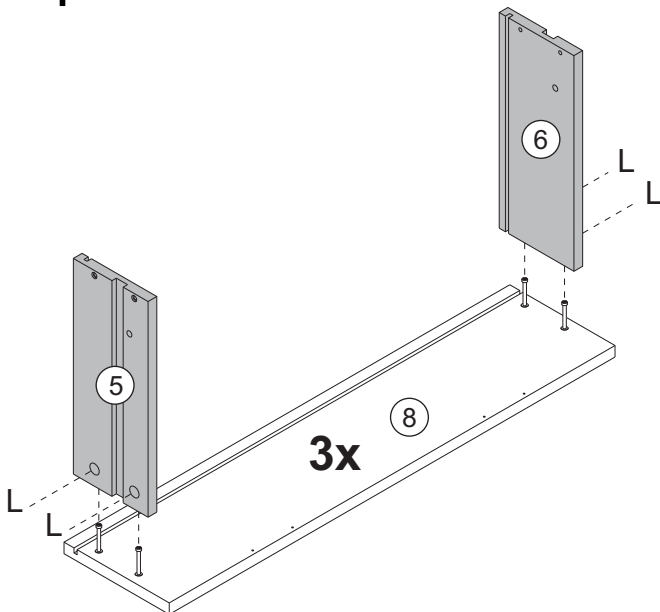

WARNING

Children have died from furniture tipover. To reduce the risk of furniture tipover:

- ALWAYS install Anti-tip device provided.
- NEVER put a TV on this product.
- NEVER allow children to stand, climb, or hang on any drawers, doors, or shelves.
- NEVER open more than one drawer at a time.
- Place heaviest items in the lowest drawer.

This is a permanent label. Do not remove!

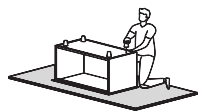
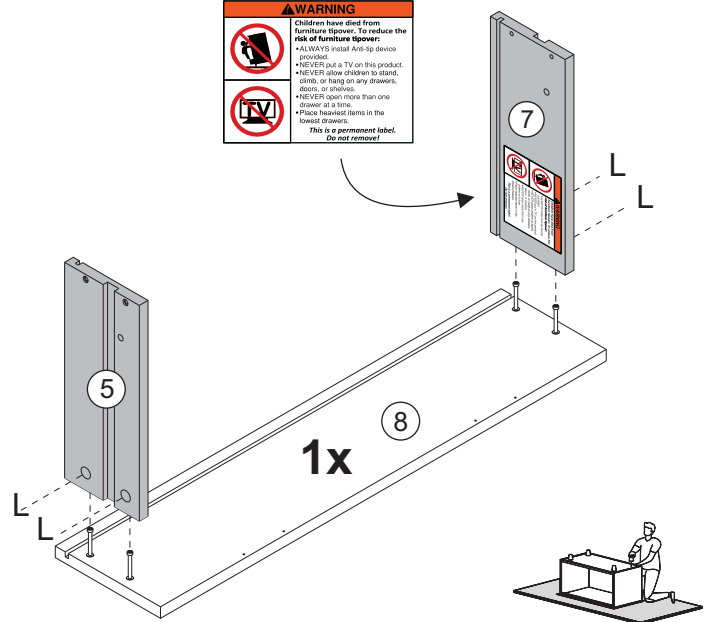

Secure parts 5 and 6 to part 8.
Secure parts 5 and 7 to part 8.
Insert cam locks (L) into parts 5, 6, 7, and tighten with a phillips head screwdriver.

L		16
		Ø15*11mm

Step 18

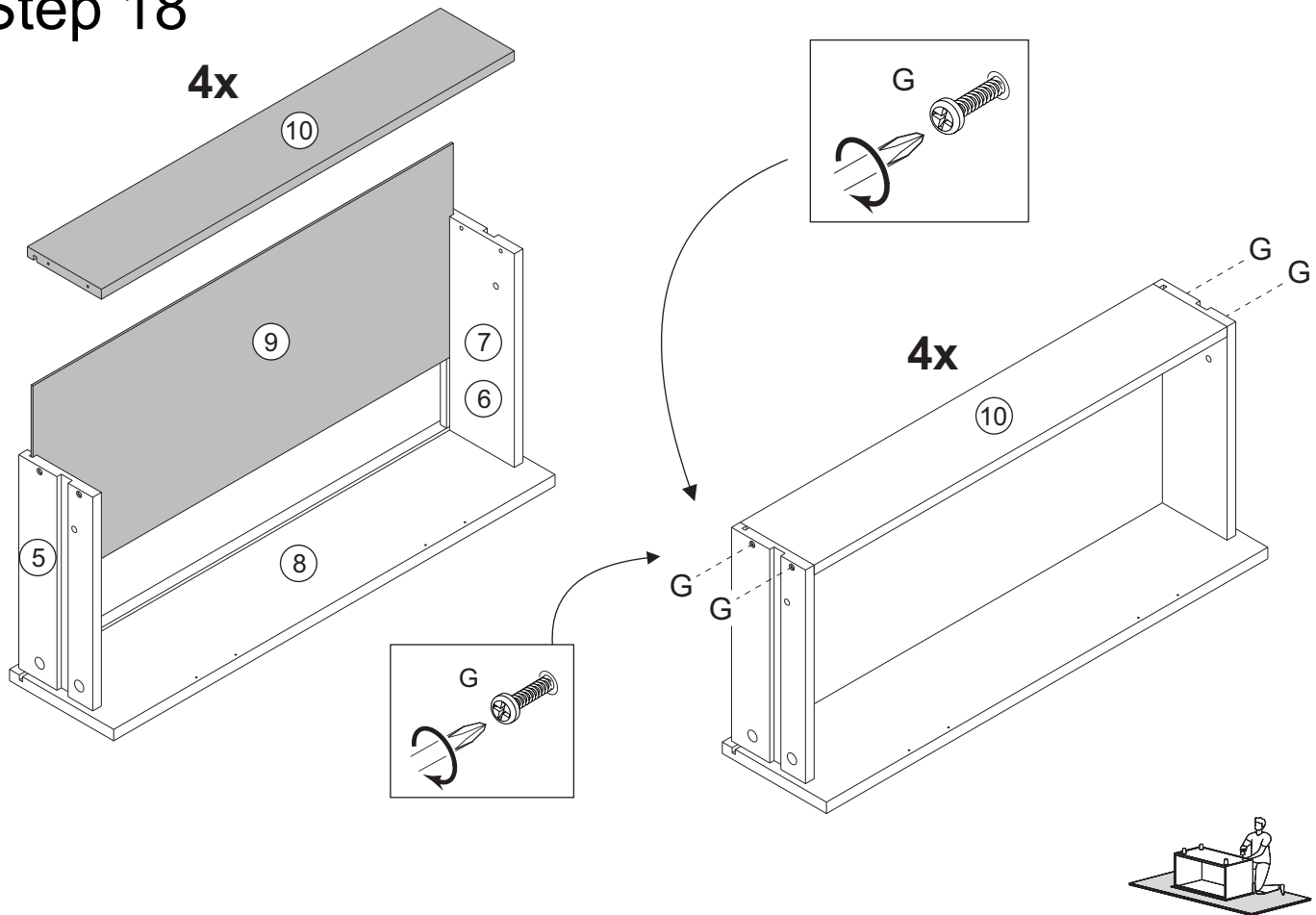

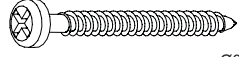

Insert part 9 between the grooves of parts 5, 6 and 7.
Secure part 10 to part 5, 6 and 7 with screw (G) and phillips head screwdriver.

G		16
<small>Ø3,5*30mm</small>		

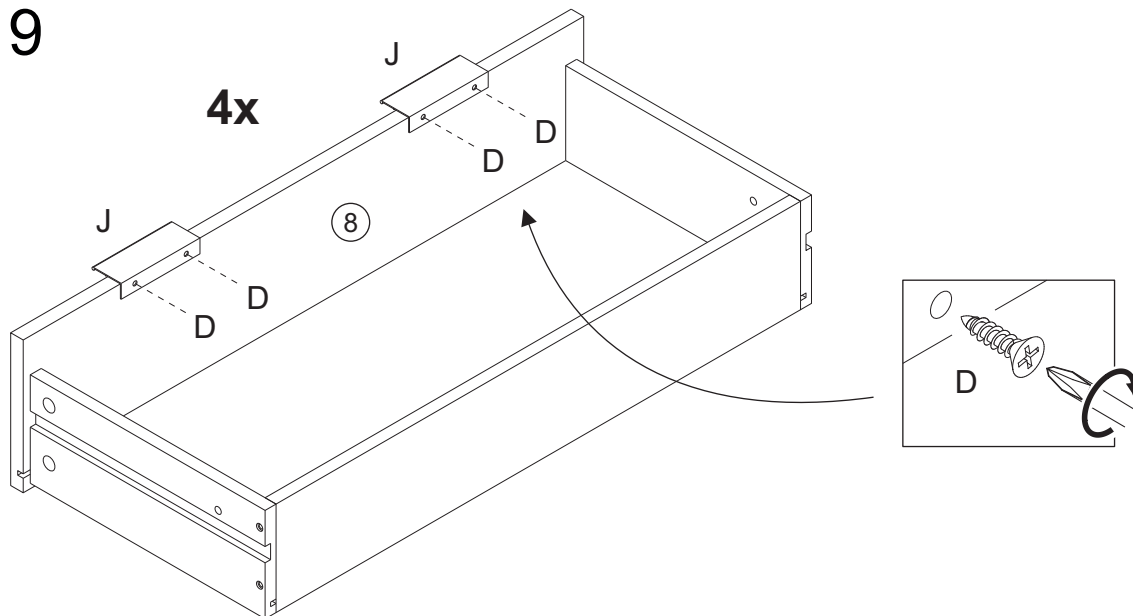
Step 19

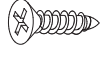

Secure handle (J) with screw (D) and phillips head screwdriver, in the pre-drilled holes on the drawer front.

D		16
<small>Ø3,0*12mm</small>		
J		08

Step 20

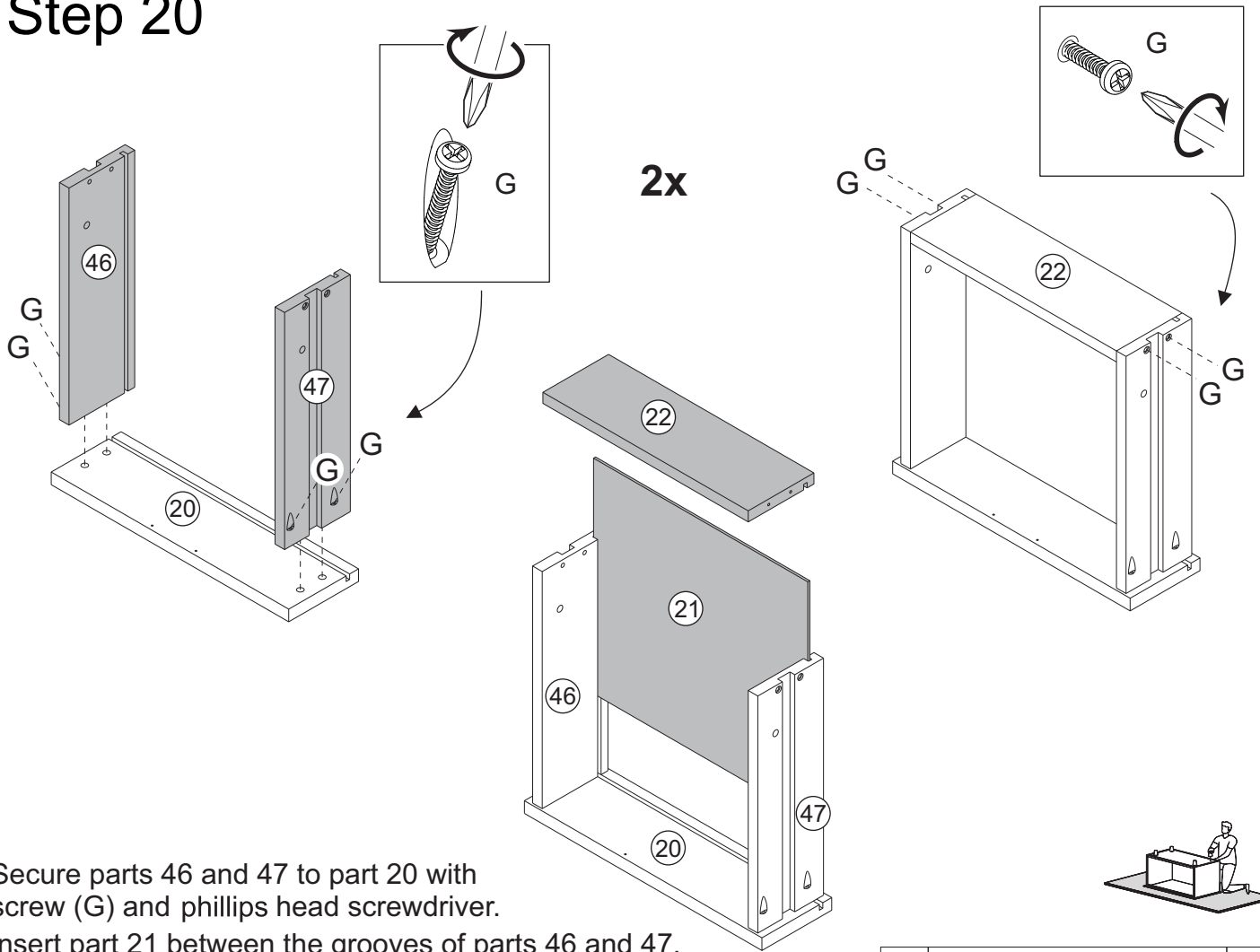

Secure parts 46 and 47 to part 20 with screw (G) and phillips head screwdriver.

Insert part 21 between the grooves of parts 46 and 47.

Secure part 22 to parts 46 and 47 with screw (G) and phillips head screwdriver.

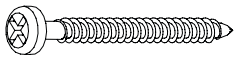
G		16
		Ø3,5*30mm

Step 21

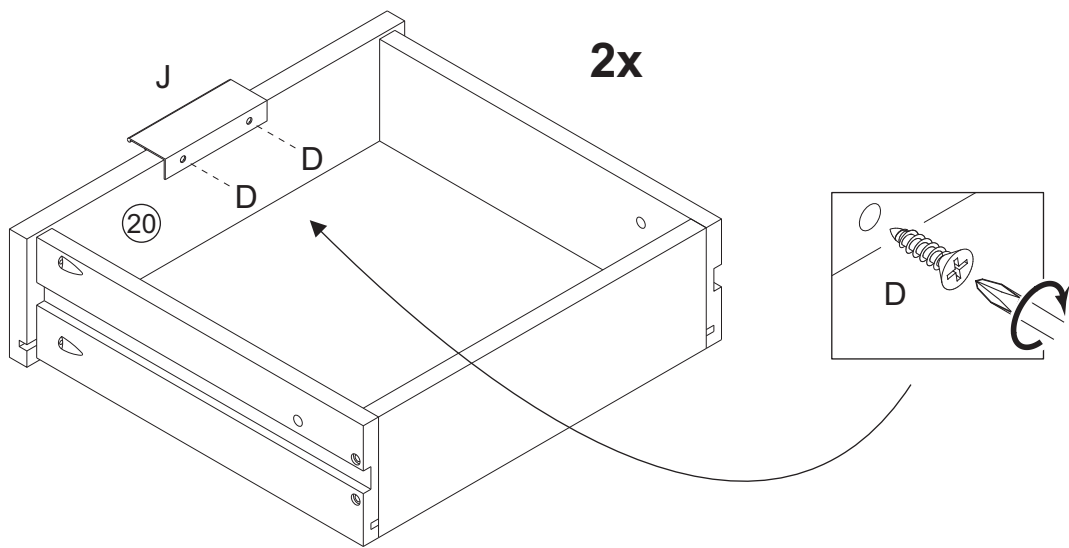

Secure handle (J) with screw (D) and phillips head screwdriver, in the pre-drilled holes on the drawer front.

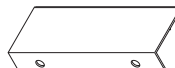
D		04
		Ø3,0*12mm
J		02

Step 22

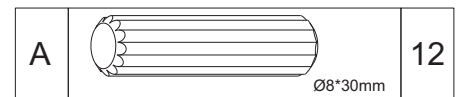
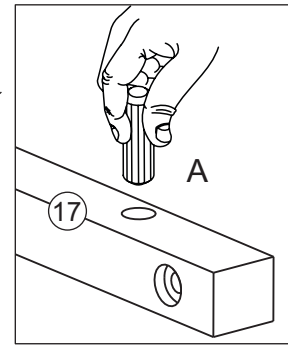
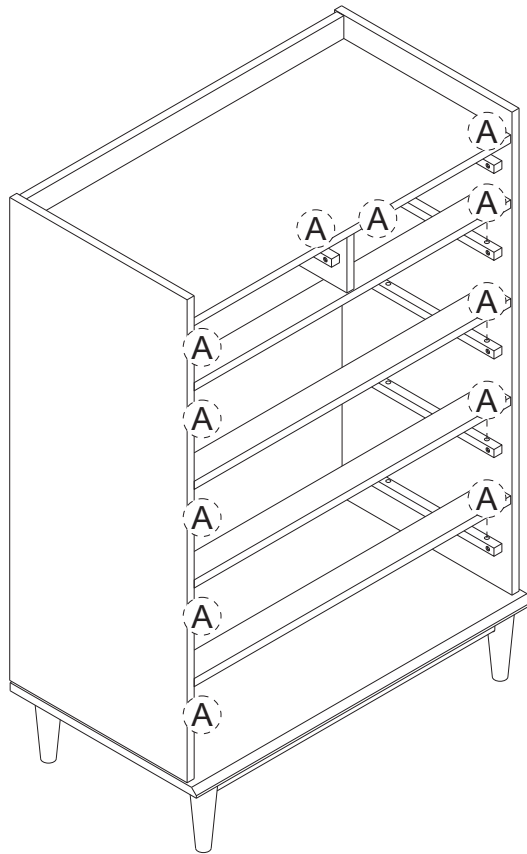

Insert wood dowel (A) into part 17 to be the stop of the drawer.

Step 23

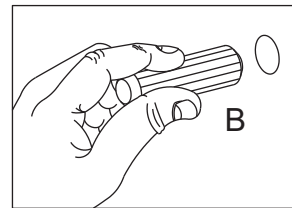
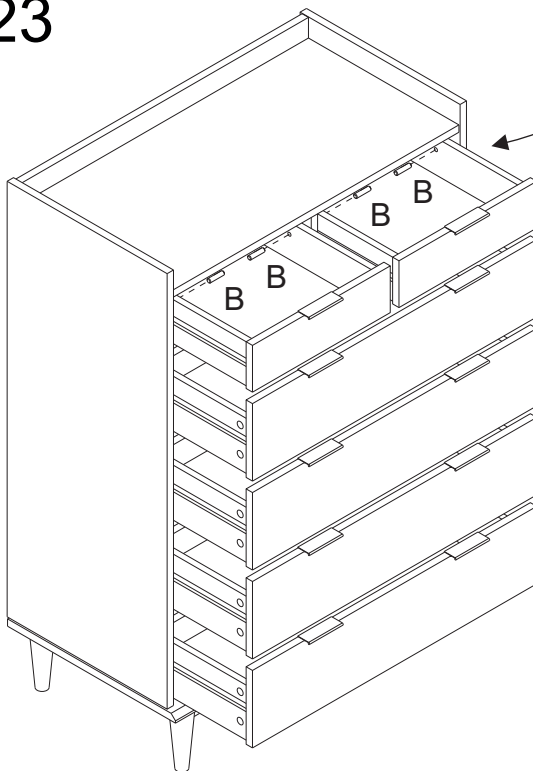

The assembled drawer with this warning must be placed on top of the unit.

Insert wood dowel (B) on the inside of all drawers, with the drawer inside the unit, after having passed the wood dowel that is in the drawer slide.

The dowel is not flush with the panel, it is a little inside the drawer to help when you need to remove the lock dowel to remove the drawer.

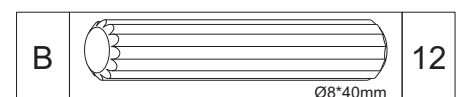

Step 24

WARNING

Serious or fatal injuries can occur from furniture tipping over. To prevent the furniture from tipping over we recommend that it is permanently fixed to the wall.

Wall anchor and hardware are included with this product. Please make sure hardware is suitable for your walls before installing, as different wall materials may require different types of anchors.

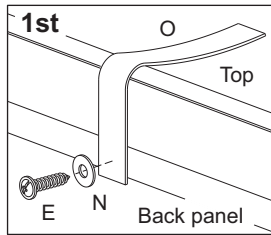

Attach part (O) with Screw (E) and Washer (N), in the frame of top panel unit.

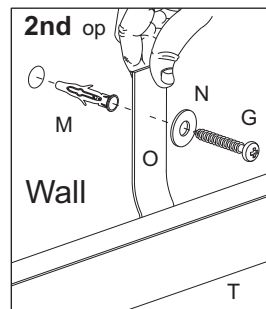
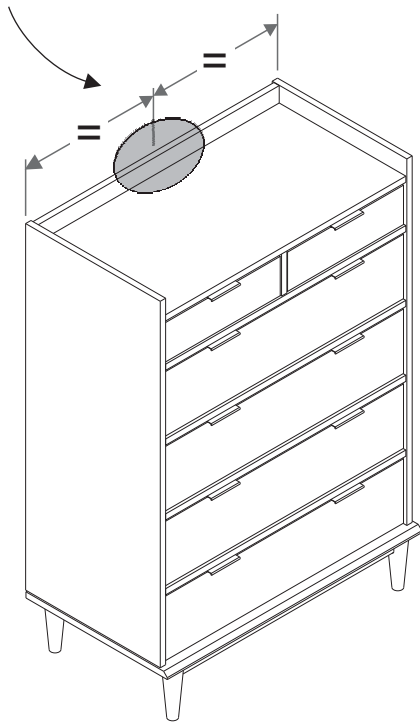
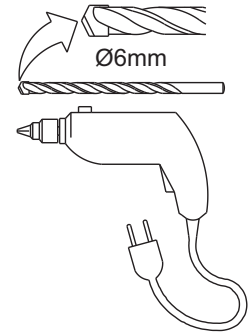

With drilling machine make one hole in the wall, Insert part (M) in the hole.
Secure part (O) with Screw (G), and Washer (N), in the wall.

Wall

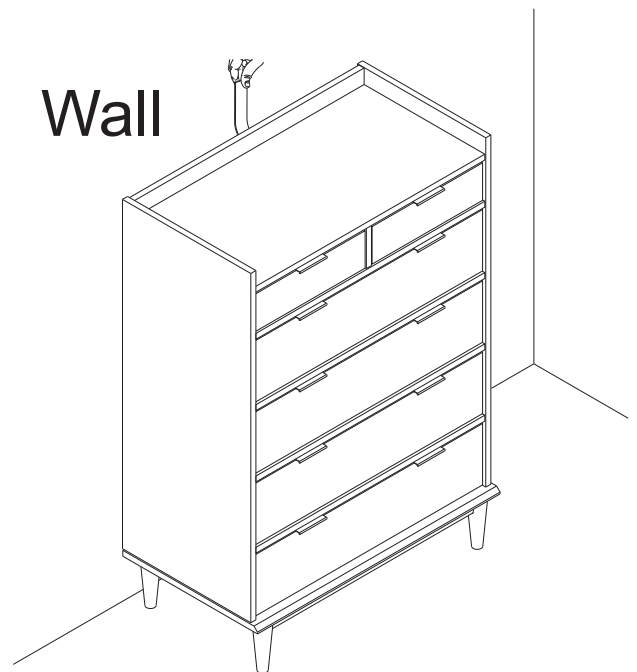

E	Ø3,5*20mm	01
G	Ø3,5*30mm	01
M		01
N		02
O		01

Name and address information for the manufacturer responsible for the anti-tip hardware and date of production can be found on the label on the back of the furniture.

Step 25

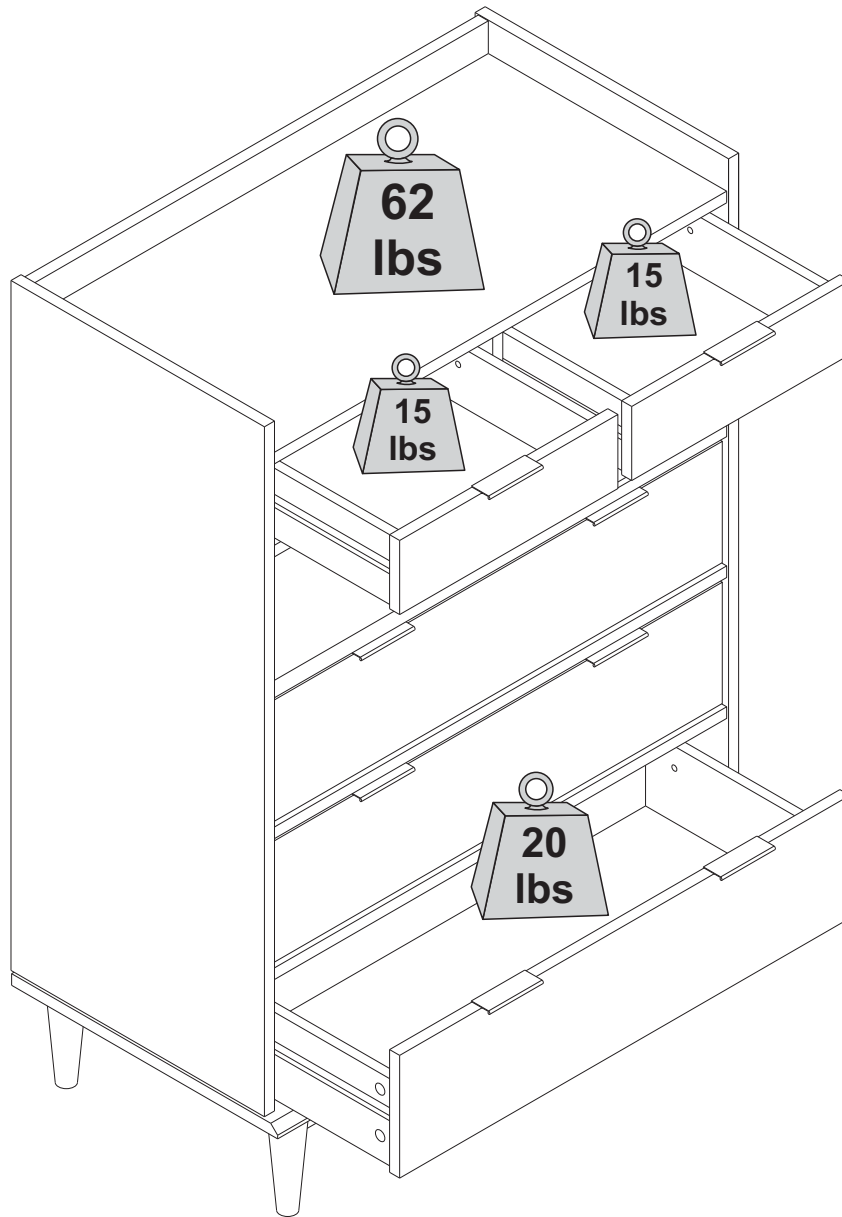

Assembly Complete!