

Step 1.

- Fold template where indicated.
- Position template on door edge at desired latch height.
- Firmly hold template and mark latch height and handle fixing holes at required backset (refer template).
- Measure door thickness and mark centre.
- Drill 25mm (1") latch hole.
- Note:** it is important to drill this hole squarely.
- Drill three 8mm (5/16") holes and one 28mm (1 1/8") to 35mm (1 3/8") hole through door face at required backset as marked on template.

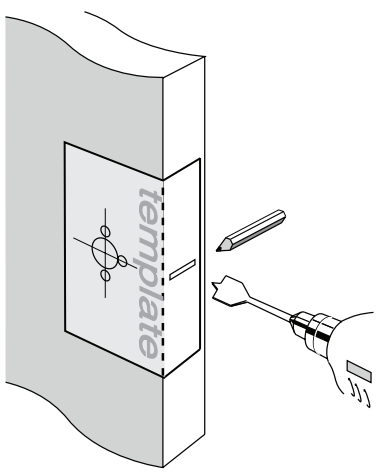

Step 2.

- Mark and chisel door edge for latch face plate to a recess of 2mm or until flush with door. Use latch face plate as a template.
-
- Insert latch into door, ensuring that:
 - The bevelled area of the latchbolt (B) is facing the direction of door closure.
 - The threaded drive bar (A) is sitting proud on both sides of the latch body
 - Pre-drill screw holes with suitable drill size.
 - Fasten with wood screws provided

Step 3.

- Insert square drive spindle (1) through latch in door. Depress button (11) and push spindle through the latch until the button is visible on the other side. The spindle is now retained in the centre of the latch.
- Identify which side of the door each lever assembly will need to be located in order to allow both levers to move in a downward motion once installed.
- Remove rosette covers (2) from both lever assemblies.
- Place one lever assembly (3) onto the square drive spindle.
- Place the other lever assembly (4) into position, locating it onto the other side of the spindle.
- Fasten both lever assemblies together with screws provided (5):
 - Use long screws for thick doors and short screws for thin doors.
 - Each under-rose features a countersunk hole and a threaded hole.
 - Install one screw from either side, through the countersunk hole and into the threaded hole of the opposite under-rose.
 - Then tighten the screw head on each side.
- Tighten the grub screws (7) at base of levers on both sides with the hexagonal key (8) provided.
- Re-apply rosette covers (2) to both under-roses by pushing the covers over the rubber rings until flush with door.
- **Depress latchbolt (B)** and install the privacy button (9) through the privacy button / emergency release hole (10) on the internal side of the door and screw tight. Ensure this is completely tightened, then release latchbolt.

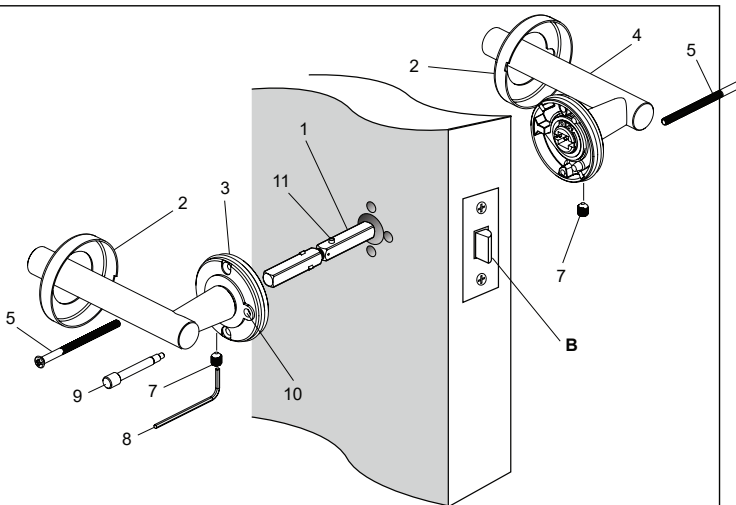

NOTE: Carefully follow these instructions when installing. Screws to be tightened to a recommended 2.5Nm torque.



Mark centre-line of latch hole

Mark centre-line of latch hole

PRINT TO SCALE

FOLD HERE

Fit here on door edge

Fit here on door edge

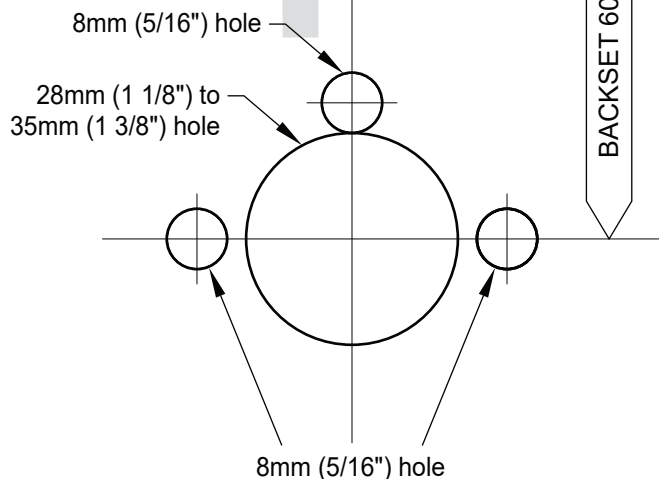

Suits doors 32mm (1 1/4") to 45mm (1 3/4") thick.

Installation template for privacy applications



gainsboroughhardware.com.au
gainsboroughhardware.co.nz