



MANUFACTURED BY:
Backyard Discovery
3305 Airport Drive, Pittsburg, KS 66762
800-856-4445

Basepoint Business Centre: Rivermead Drive, Westlea, Swindon SN5 7EX Phone: 0800-118-2476
J.P. Coenstraat 7, The Bridge, The Hague, 2595 WP, Netherlands Phone: 0800-567-8990

MALIBU

Swing Set

Model # 1606036B

The assembly manual must be retained since it contains important information



WARNING

Adult Assembly Required.

Not suitable for children under 36 months due to small parts.

FOR DOMESTIC USE ONLY. INTENDED FOR OUTDOOR USE.



Please visit www.backyarddiscovery.com

For the most up to date assembly manual, to register your set, or to order replacement parts

Para obtener instrucciones en español, visite www.backyarddiscovery.com



EASY STEP-BY-STEP
3D INTERACTIVE INSTRUCTIONS

DOWNLOAD THE FREE APP



INSTALLATION
SERVICES
AVAILABLE!
See inside for details

Made in China
INS-1606036B-A-MALIBU-ENG 03-14-22

Owner's Manual - Basic Setup Dimensions & Assembly Notes

Place the set on level ground, not less than 6'-7" [2 m] from any structure or obstruction such as a fence, garage, house, overhanging branches, laundry lines, or electrical wires.

- While assembling unit, take time before and after each phase to make sure fort is level. If fort is not level, assembly will be difficult and improper assembly may result. Extra care must be taken to insure the fort is square.
- The safe play area refers to a zone extending 6'-7" (2 m) beyond the play product on all sides, including the space above the play product.

SAFE PLAY AREA DIAGRAM

Ground Dimensions

16'-6" [5.0 m] x 20'-10 1/4" [6.4 m]

Safe Play Area

34'-0" [10.4 m] x 29'-8 3/4" [9.1 m] x 17'-10 1/4" [5.4 m]

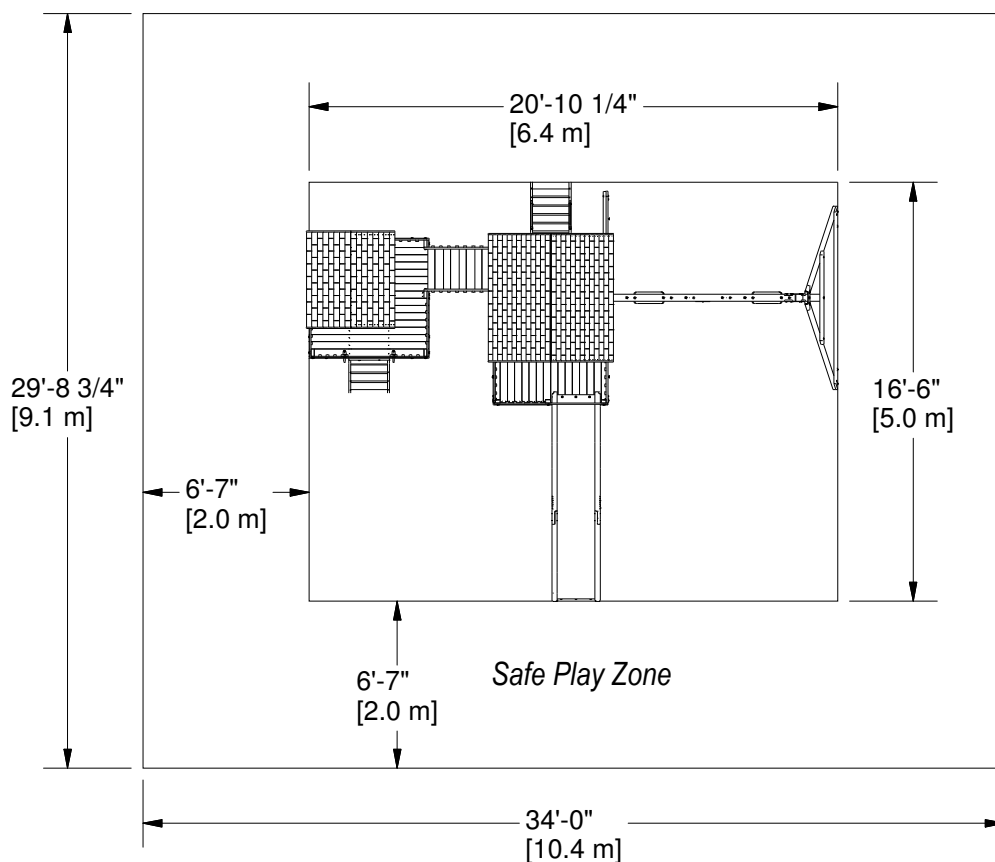

SAFE PLAY HEIGHT: 17'-10 1/4" [5.4 m]
 MAXIMUM FALL HEIGHT: 7'-0 1/4" [2.1 m]

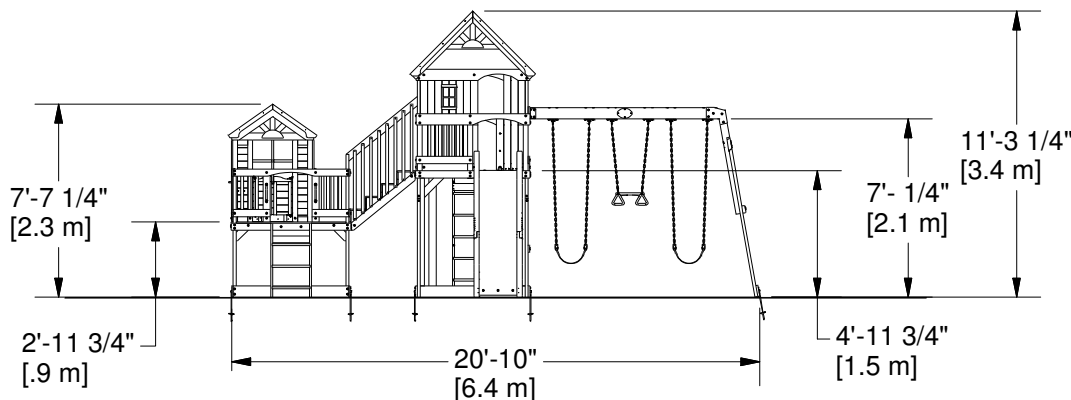

General Information:

Your set has been designed and engineered for children only and for residential use only.
 A maximum of 150 lbs. per child is recommended for play activities designed for individual use.
 A maximum of 120 lbs. per child is recommended for play activities designed for multiple child use.
 A maximum of 9 children is recommended for this swing set.

Owner's Manual - Parts Identification

Wood Components (Not to Scale)



A50 | SWING BEAM - W4L16822
(x1) | 3 3/8"x5 1/4"x89 1/2" (86x134x2274)

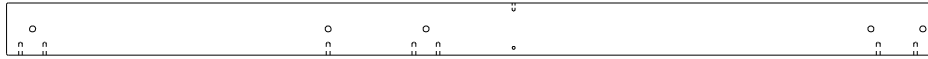

E1 | LEFT FRONT UPRIGHT - W4L16905
(x1) | 1 3/8"x3 3/8"x60 5/8" (36x86x1540)

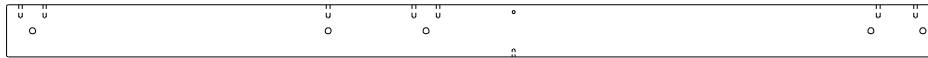

E2 | RIGHT FRONT UPRIGHT - W4L16906
(x1) | 1 3/8"x3 3/8"x60 5/8" (36x86x1540)

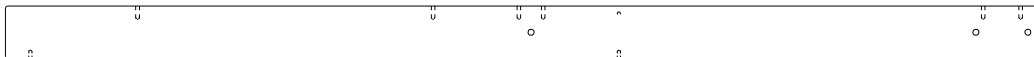

E3 | RIGHT REAR UPRIGHT - W4L16907
(x1) | 1 3/8"x3 3/8"x67 1/2" (36x86x1715)



E4 | LEFT REAR UPRIGHT - W4L16908
(x1) | 1 3/8"x3 3/8"x35" (36x86x889)



E5 | RAIL UPRIGHT - W4L16832
(x1) | 1 3/8"x3 3/8"x35 7/8" (36x86x912)



E6 | DECK BRACE - W4L16834
(x8) | 1 3/8"x3 3/8"x11 15/16" (36x86x303)



E7 | FRONT LEFT UPRIGHT - W4L16884
(x1) | 1 3/8"x3 3/8"x84" (36x86x2135)

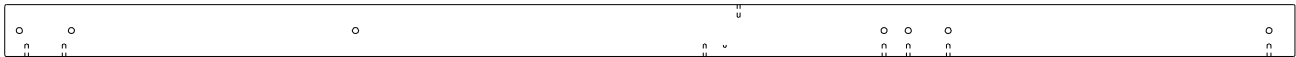

E8 | REAR RIGHT UPRIGHT - W4L16901
(x1) | 1 3/8"x3 3/8"x84" (36x86x2135)



E9 | FRONT RIGHT UPRIGHT - W4L16900
(x1) | 1 3/8"x3 3/8"x84" (36x86x2135)

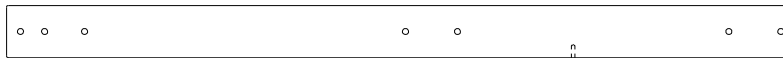

E10 | FORT UPRIGHT - W4L16899
(x1) | 1 3/8"x3 3/8"x51 3/8" (36x86x1305)



E11 | RIGHT FORT UPRIGHT - W4L16902
(x2) | 1 3/8"x3 3/8"x23 3/4" (36x86x602)



E12 | LEFT FORT UPRIGHT - W4L16885
(x1) | 1 3/8"x3 3/8"x23 3/4" (36x86x602)



E13 | DECK BRACE - W4L16880
(x8) | 1 3/8"x3 3/8"x16 7/8" (36x86x428)



E14 | ANGLE BRACE - W4L16881
(x3) | 1 3/8"x3 3/8"x51 3/4" (36x86x1315)



E15 | FORT UPRIGHT - W4L16593
(x1) | 1 3/8"x3 3/8"x23 3/4" (36x86x602)

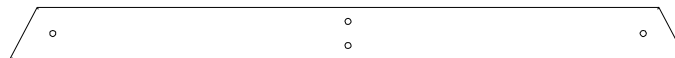

E79 | END SUPPORT - W4L16825
(x1) | 1 1/2"x3 1/2"x44" (36x86x1120)



E80 | ANGLE BRACE - W4L16824
(x2) | 1 3/8"x3 3/8"x87 1/8" (36x86x2212)

Owner's Manual - Parts Identification

Wood Components (Not to Scale)



F1 | RIGHT DECK UPRIGHT - W4L06440
(x1) | 1 3/8"x2 3/8"x30 3/8" (36x60x770)



F2 | DECK UPRIGHT - W4L06441
(x1) | 1 3/8"x2 3/8"x30 3/8" (36x60x770)



F3 | LEFT DECK UPRIGHT - W4L06445
(x1) | 1 3/8"x2 3/8"x30 3/8" (36x60x770)



G1 | WALL RAIL - W4L06469
(x1) | 1"x5 1/4"x76 7/8" (24x134x1952)



G3 | GROUND BOARD - W4L16878
(x1) | 1"x5 1/4"x78 1/2" (24x134x1995)



G5 | GROUND BOARD - W4L16882
(x2) | 1"x5 1/4"x52 3/4" (24x134x1341)



G6 | GROUND BOARD - W4L16883
(x2) | 1"x5 1/4"x52 1/2" (24x134x1335)



G50 | GROUND BOARD - W4L16826
(x1) | 1"x5 1/4"x86 11/16" (24x134x2202)



H1 | FLOOR RAIL - W4L06391
(x1) | 1"x3 3/8"x56 3/4" (24x86x1442)



H2 | FLOOR RAIL - W4L06392
(x1) | 1"x3 3/8"x54 7/8" (24x86x1394)



H3 | FLOOR RAIL - W4L06395
(x1) | 1"x3 3/8"x56 3/4" (24x86x1442)



H4 | FLOOR RAIL - W4L06396
(x1) | 1"x3 3/8"x54 7/8" (24x86x1394)



H5 | FLOOR SUPPORT - W4L06399
(x2) | 1"x3 3/8"x54 7/8" (24x86x1394)

Owner's Manual - Parts Identification

Wood Components (Not to Scale)

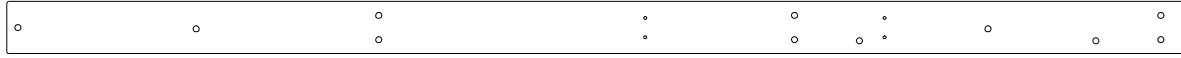

H6 | FLOOR RAIL - W4L06435
(x1) | 1"x3 3/8"x76 7/8" (24x86x1952)



H7 | FLOOR RAIL - W4L06436
(x1) | 1"x3 3/8"x76 7/8" (24x86x1952)



H8 | FLOOR RAIL - W4L06437
(x1) | 1"x3 3/8"x52 1/2" (24x86x1335)

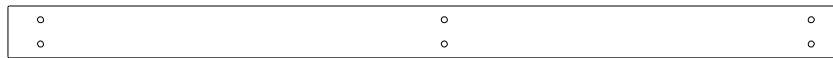

H9 | FLOOR RAIL - W4L16592
(x1) | 1"x3 3/8"x54 1/2" (24x86x1383)



H10 | FLOOR RAIL - W4L06439
(x1) | 1"x3 3/8"x54 1/2" (24x86x1383)

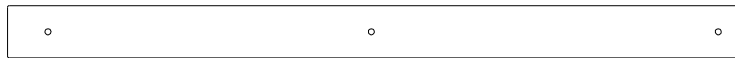

H12 | WALL BOARD - W4L06472
(x4) | 1"x3 3/8"x48" (24x86x1219)



H13 | SWING BEAM MOUNT - W4L06533
(x1) | 1"x3 3/8"x54 3/8" (24x86x1380)



H14 | STAIR HAND RAIL - W4L06622
(x2) | 1"x3 3/8"x47 1/2" (24x86x1205)



H15 | FLOOR SUPPORT BLOCK - W4L16831
(x1) | 1"x3 3/8"x3 3/8" (24x86x86)



H16 | ATTACHMENT BOARD - W4L16846
(x2) | 1"x3 3/8"x19 1/4" (24x86x488)



H75 | RIGHT UPRIGHT - W4L16916
(x1) | 1"x3 3/8"x38 3/8" (24x86x976)



H76 | LADDER RUNG - W4L06609
(x8) | 1"x3 3/8"x18 1/8" (24x86x460)



H77 | LEFT UPRIGHT - W4L16847
(x1) | 1"x3 3/8"x64 3/8" (24x86x1634)

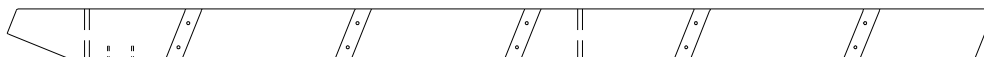

H78 | LEFT UPRIGHT - W4L16848
(x1) | 1"x3 3/8"x64 3/8" (24x86x1634)



H79 | LEFT UPRIGHT - W4L06611
(x1) | 1"x3 3/8"x38 3/8" (24x86x976)



H80 | SLIDE BRACE WIDE - W4L15715
(x1) | 1"x3 3/8"x18 3/8" (24x86x466)



H81 | SLIDE BRACE UPRIGHT - W4L13301
(x2) | 1"x3 3/8"x22 7/8" (24x86x580)

Owner's Manual - Parts Identification

Wood Components (Not to Scale)



J2 | COUNTER TOP SUPPORT - W4L16909
(x2) | 1"x2 3/8"x5 7/8" (24x60x150)

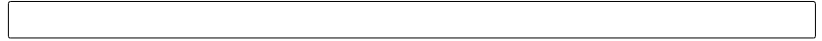

J4 | FLOOR SUPPORT - W4L06454
(x2) | 1"x2 3/8"x52 1/2" (24x60x1335)



J9 | SUPPORT BOARD - W4L06064
(x3) | 1"x2 3/8"x3" (24x60x76)



K1 | GROUND BOARD - W4L06389
(x2) | 5/8"x5 1/4"x54 7/8" (16x134x1394)



K2 | GROUND BOARD - W4L06390
(x2) | 5/8"x5 1/4"x56 1/8" (16x134x1426)

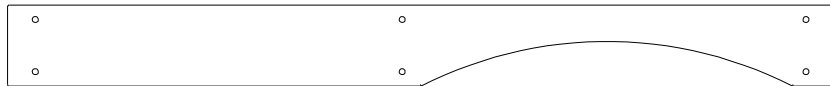

K8 | ARCHED WALL RAIL - W4L16591
(x1) | 5/8"x5 1/4"x54 1/8" (16x134x1375)

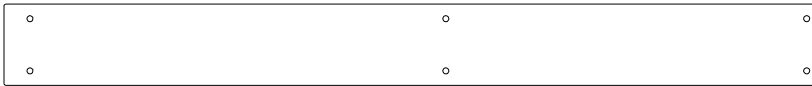

K10 | WALL RAIL - W4L06462
(x1) | 5/8"x5 1/4"x53" (16x134x1346)



K11 | WALL RAIL - W4L06470
(x1) | 5/8"x5 1/4"x3 3/8" (16x134x86)



K12 | ARCHED WALL RAIL - W4L06471
(x1) | 5/8"x5 1/4"x54 1/8" (16x134x1375)



K13 | WALL RAIL - W4L06473
(x1) | 5/8"x5 1/4"x28 5/8" (16x134x728)



K14 | WALL RAIL - W4L06474
(x1) | 5/8"x5 1/4"x4 3/4" (16x134x122)

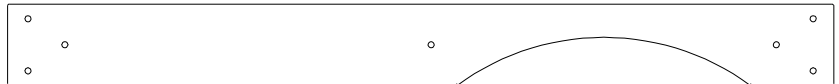

K15 | ARCHED WALL RAIL - W4L06479
(x1) | 5/8"x5 1/4"x53 7/8" (16x134x1367)



K16 | ARCHED WALL RAIL - W4L06530
(x1) | 5/8"x5 1/4"x54 3/8" (16x134x1380)

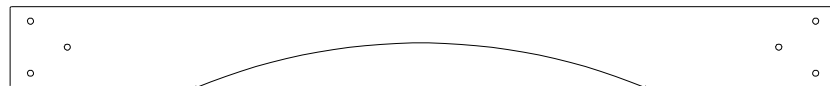

K17 | ARCHED WALL RAIL - W4L06531
(x1) | 5/8"x5 1/4"x53 7/8" (16x134x1367)



K18 | WALL RAIL - W4L06532
(x1) | 5/8"x5 1/4"x54 3/8" (16x134x1380)



K19 | STAIR BOARD - W4L06619
(x2) | 5/8"x5 1/4"x20 5/8" (16x134x525)



L1 | FLOOR BOARD - W4L06400
(x1) | 5/8"x4 3/8"x52" (16x112x1321)

Owner's Manual - Parts Identification

Wood Components (Not to Scale)



L2 | FLOOR BOARD - W4L06404
(x1) | 5/8"x4 3/8"x54 3/8" (16x112x1382)



L3 | GABLE BOARD - W4L06412
(x4) | 5/8"x4 3/8"x25 3/8" (16x112x644)

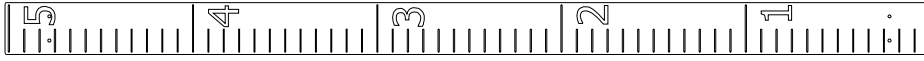

M1 | GROWTH BOARD - W4L06143
(x1) | 5/8"x3 3/8"x60 1/4" (16x86x1530)

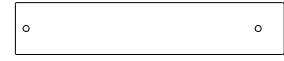

M2 | WALL RAIL - W4L06393
(x2) | 5/8"x3 3/8"x17 1/2" (16x86x445)

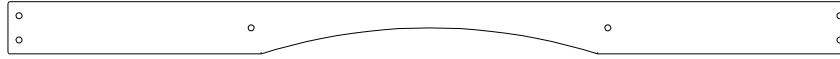

M3 | WALL RAIL - W4L06394
(x1) | 5/8"x3 3/8"x54 7/8" (16x86x1394)



M4 | FLOOR BOARD - W4L16829
(x13) | 5/8"x3 3/8"x56 3/4" (16x86x1442)



M5 | FLOOR BOARD - W4L16830
(x1) | 5/8"x3 3/8"x54 3/8" (16x86x1382)



M6 | WALL BOARD - W4L16833
(x2) | 5/8"x3 3/8"x25" (16x86x635)



M7 | WALL RAIL - W4L06406
(x2) | 5/8"x3 3/8"x31 1/2" (16x86x799)



M8 | WALL RAIL - W4L06409
(x2) | 5/8"x3 3/8"x17 1/4" (16x86x439)

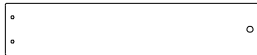

M9 | WALL RAIL - W4L06410
(x2) | 5/8"x3 3/8"x16 5/8" (16x86x423)

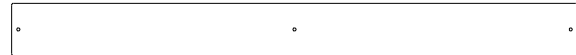

M10 | COUNTER TOP - W4L16910
(x2) | 5/8"x3 3/8"x36 7/8" (16x86x936)

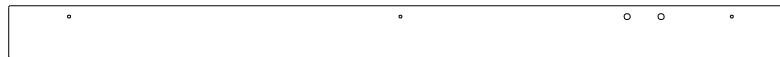

M11 | FRONT CORNER BOARD - W4L16903
(x2) | 5/8"x3 3/8"x51" (16x86x1297)

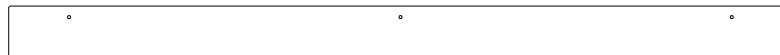

M12 | REAR CORNER BOARD - W4L16914
(x1) | 5/8"x3 3/8"x51" (16x86x1297)



M13 | REAR CORNER BOARD - W4L16904
(x1) | 5/8"x3 3/8"x51" (16x86x1297)



M14 | FLOOR BOARD - W4L16828
(x13) | 5/8"x3 3/8"x21 1/2" (16x86x546)



M15 | FLOOR BOARD - W4L16589
(x1) | 5/8"x3 3/8"x21 1/2" (16x86x546)

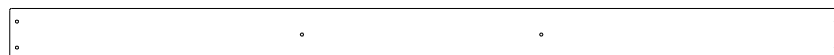

M16 | FLOOR BOARD - W4L16827
(x14) | 5/8"x3 3/8"x54 1/4" (16x86x1379)

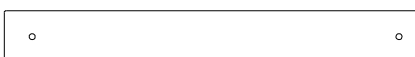

M17 | WALL RAIL - W4L16590
(x1) | 5/8"x3 3/8"x26 7/8" (16x86x683)



M18 | WALL RAIL - W4L06461
(x2) | 5/8"x3 3/8"x25 7/8" (16x86x658)

Owner's Manual - Parts Identification

Wood Components (Not to Scale)



M19 | WALL RAIL - W4L16838
(x1) | 5/8"x3 3/8"x29 1/4" (16x86x744)



M20 | WALL RAIL - W4L06464
(x1) | 5/8"x3 3/8"x5 3/8" (16x86x138)



M21 | WALL RAIL - W4L06465
(x1) | 5/8"x3 3/8"x54 3/8" (16x86x1380)



M22 | WALL RAIL - W4L06466
(x1) | 5/8"x3 3/8"x30 1/2" (16x86x774)



M23 | WALL RAIL - W4L06467
(x1) | 5/8"x3 3/8"x3 3/8" (16x86x86)



M24 | WALL RAIL - W4L16836
(x2) | 5/8"x3 3/8"x15 5/8" (16x86x398)

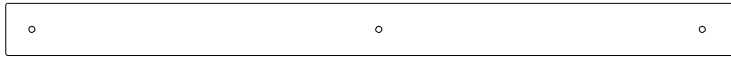

M25 | WALL BOARD - W4L16837
(x1) | 5/8"x3 3/8"x48" (16x86x1219)



M26 | WALL BOARD - W4L16835
(x2) | 5/8"x3 3/8"x26 7/8" (16x86x684)

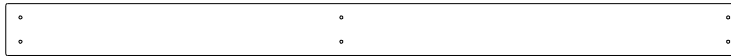

M27 | WALL BOARD - W4L06534
(x8) | 5/8"x3 3/8"x48" (16x86x1219)

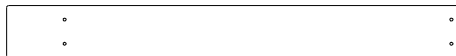

M28 | WALL BOARD - W4L06535
(x2) | 5/8"x3 3/8"x29 7/8" (16x86x760)



M29 | WALL BOARD - W4L06536
(x2) | 5/8"x3 3/8"x8 1/4" (16x86x210)



M30 | WALL BOARD - W4L06537
(x21) | 5/8"x3 3/8"x26 7/8" (16x86x684)

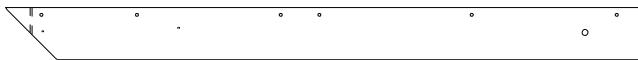

M31 | GABLE BOARD - W4L06538
(x2) | 5/8"x3 3/8"x41 3/8" (16x86x1052)

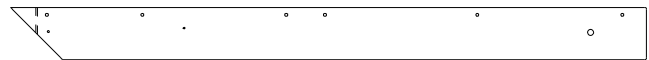

M32 | GABLE BOARD - W4L06539
(x2) | 5/8"x3 3/8"x41 3/8" (16x86x1052)

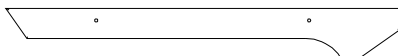

M33 | FASCIA BOARD - W4L06559
(x4) | 5/8"x3 3/8"x25 5/8" (16x86x652)



M34 | FASCIA BOARD - W4L06560
(x4) | 5/8"x3 3/8"x42" (16x86x1068)

Owner's Manual - Parts Identification

Wood Components (Not to Scale)



M35 | STAIR BOARD - W4L06618
(x7) | 5/8"x3 3/8"x20 5/8" (16x86x525)



M36 | FILLER BOARD - W4L06800
(x1) | 5/8"x3 3/8"x3" (16x86x76)



M37 | FILLER BOARD - W4L06801
(x1) | 5/8"x3 3/8"x6 3/4" (16x86x170)



M38 | SAFETY BOARD - W4L07011
(x1) | 5/8"x3 3/8"x54 3/8" (16x86x1380)

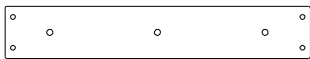

M70 | SLIDE BED SUPPORT - W100935
(x1) | 5/8"x3 3/8"x19 7/8" (16x86x505)



M73 | REAR SUPPORT - W4L06608
(x2) | 5/8"x3 3/8"x19 1/4" (16x86x488)



N1 | TIE STRAP - W4L05043
(x8) | 5/8"x2"x3 1/8" (16x50x80)



N2 | REAR WINDOW SHELF - W4L06414
(x1) | 5/8"x2 3/8"x18 7/8" (16x60x479)



N3 | LEFT WINDOW SHELF - W4L06415
(x1) | 5/8"x2 3/8"x19 1/8" (16x60x485)



N5 | FLOOR BOARD - W4L06451
(x2) | 5/8"x2 3/8"x20 1/8" (16x60x510)



N6 | FLOOR BOARD - W4L06456
(x1) | 5/8"x2 3/8"x54 1/4" (16x60x1379)

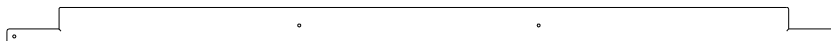

N7 | FLOOR BOARD - W4L06457
(x1) | 5/8"x2 3/8"x54 1/4" (16x60x1379)



N8 | GABLE BOARD - W4L06558
(x2) | 5/8"x2 3/8"x34 3/4" (16x60x884)



O1 | PICKET - W4L06623
(x16) | 5/8"x1 3/8"x33 1/8" (16x34x840)

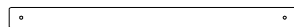

O2 | PICKET - W4L06407
(x33) | 5/8"x1 3/8"x18 3/4" (16x34x476)

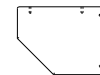

Q1 | COUNTER TOP SUPPORT - W4L16911
(x1) | 1"x4 3/8"x5 7/8" (24x112x150)



S1 | RAIL BOARD - W4L06408
(x2) | 1"x1"x25 1/4" (24x24x640)



S2 | WINDOW TRIM - W4L16912
(x2) | 1"x1"x22" (24x24x558)



S3 | WINDOW TRIM - W4L16913
(x2) | 1"x1"x23 1/8" (24x24x588)

Owner's Manual - Parts Identification

Wood Components (Not to Scale)



SP71 | SWING BEAM SUPPORT - W4L16823
(x1) | 3 3/8"x3 3/8"x49 1/2" (86x86x1256)



T1 | SUPPORT BOARD - W4L16586
(x1) | 1"x1 3/8"x21 1/2" (24x34x545)



T2 | SUPPORT BOARD - W4L16587
(x1) | 1"x1 3/8"x23 7/8" (24x34x606)



T3 | SUPPORT BOARD - W4L06444
(x2) | 1"x1 3/8"x49 5/8" (24x34x1262)

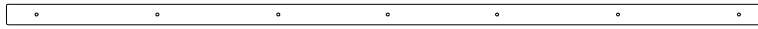

T4 | SUPPORT BOARD - W4L16588
(x1) | 1"x1 3/8"x49 5/8" (24x34x1262)



Y1 | STAIR BOARD - W4L06621
(x3) | 5/8"x4"x20 5/8" (16x102x525)



Y2 | STAIR BOARD - W4L06620
(x3) | 5/8"x2 5/8"x20 5/8" (16x67x525)

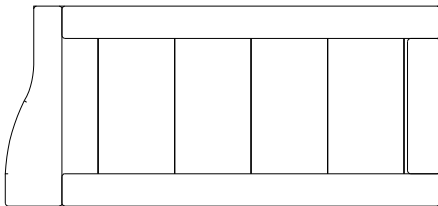

DP1 | RIGHT DOOR ASSEMBLY - W2A01927
(x1) | 1 1/8"x8 3/8"x18 1/8" (27x211x460)

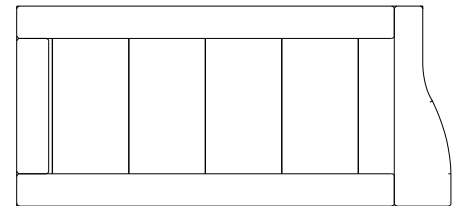

DP2 | LEFT DOOR ASSEMBLY - W2A01928
(x1) | 1 1/8"x8 3/8"x18 1/8" (27x211x460)

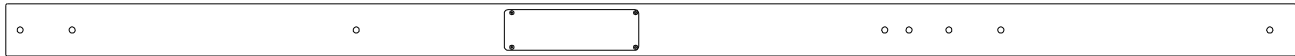

E15 | FRONT RIGHT UPRIGHT - W2A03505
(x1) | 1 3/8"x3 3/8"x84" (36x86x2135)

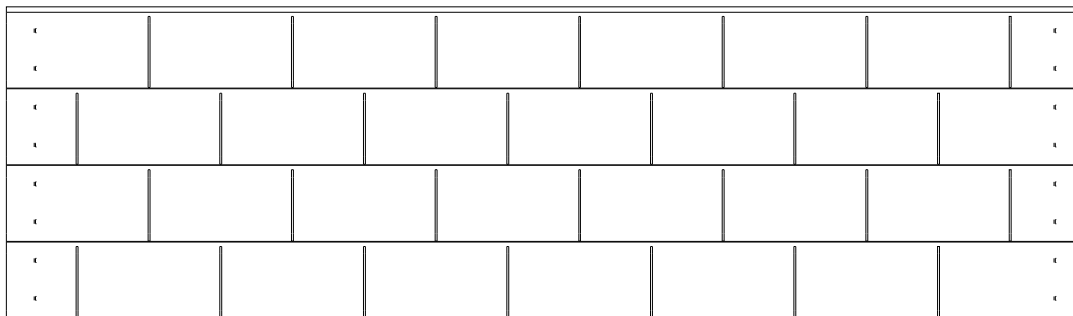

RP1 | LOWER ROOF PANEL - W2A01929
(x2) | 1 3/8"x12 15/16"x44 7/8" (35x329x1140)

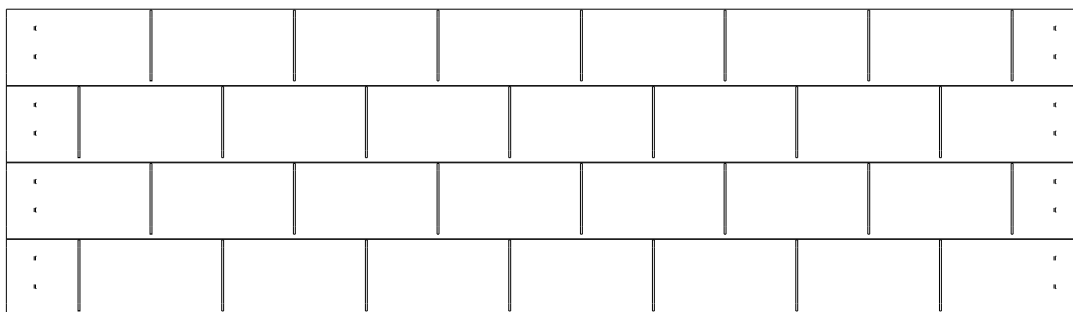

RP2 | UPPER ROOF PANEL - W2A01930
(x2) | 1 3/8"x12 3/4"x44 7/8" (35x324x1140)

Owner's Manual - Parts Identification

Wood Components (Not to Scale)

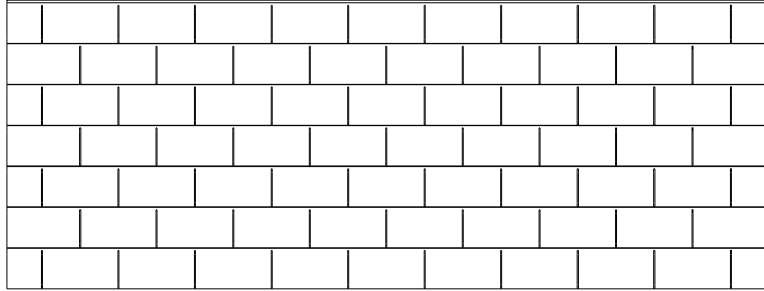

RP3 | LOWER ROOF PANEL - W2A03483
(x2) | 1 3/8"x22 1/2"x59 5/8" (35x572x1514)

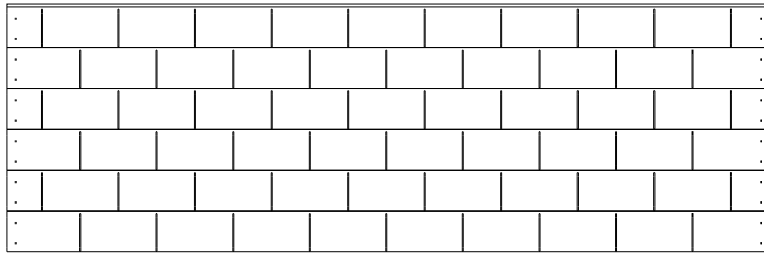

RP4 | UPPER ROOF PANEL - W2A03482
(x2) | 1 3/8"x19 3/8"x59 5/8" (35x491x1514)

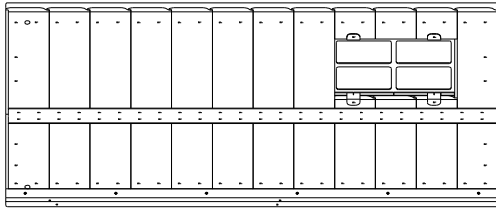

WP1 | FRONT RIGHT CORNER PANEL - W2A03487
(x1)

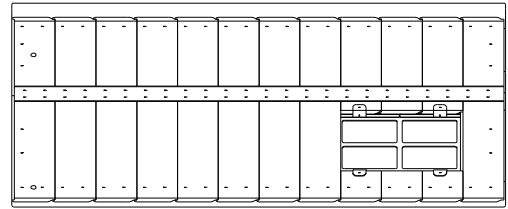

WP2 | REAR RIGHT CORNER PANEL - W2A03490
(x1)

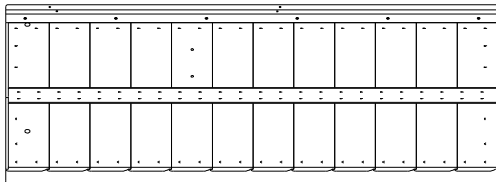

WP3 | FRONT LEFT CORNER PANEL - W2A03493
(x1)

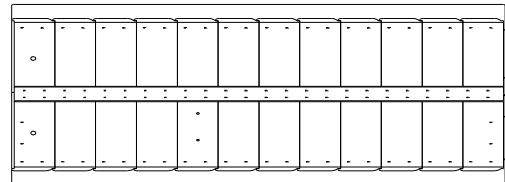

WP4 | REAR LEFT CORNER PANEL - W2A03496
(x1)

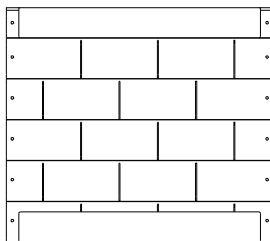

WP6 | REAR CENTER WALL - W2A03506
(x1) | 1 1/4"x18 1/4"x20 7/8" (32x465x530)

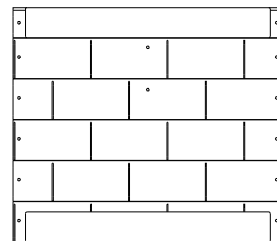

WP6 | LEFT CENTER WALL - W2A03507
(x1) | 1 1/4"x18 1/4"x21 1/8" (32x465x536)

Owner's Manual - Parts Identification

Wood Components (Not to Scale)

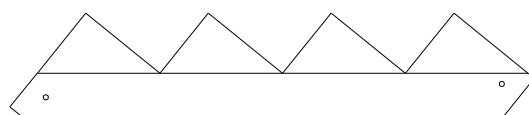
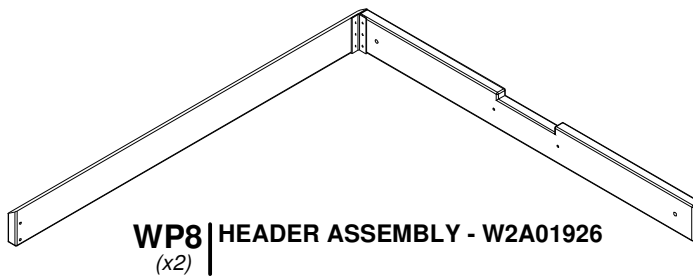

SR1 | STAIR STRINGER ASSEMBLY - W2A03486
(x2) | 1"x8 1/8"x41" (24x205x1041)

Owner's Manual - Parts Identification

Hardware Components

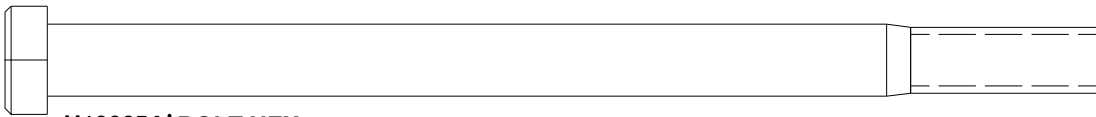

H100654 | BOLT HEX
(x13) | 3/8x5-1/2

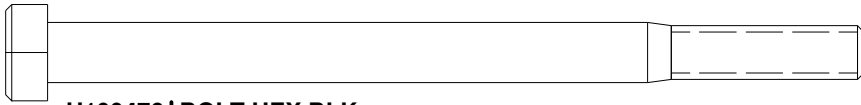

H100476 | BOLT HEX BLK
(x2) | 5/16x4 1/4

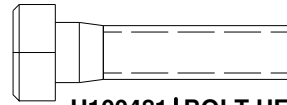

H100481 | BOLT HEX BLK
(x4) | 5/16x1 1/4



H100480 | BOLT WH BLK
(x2) | 5/16x4 3/4

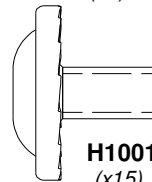

H100115 | BOLT WH
(x15) | 5/16x1/2



H100503 | BOLT WH BLK
(x2) | 5/16x3-1/2

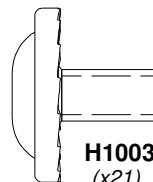

H100396 | BOLT WH BLK
(x21) | 5/16x1/2

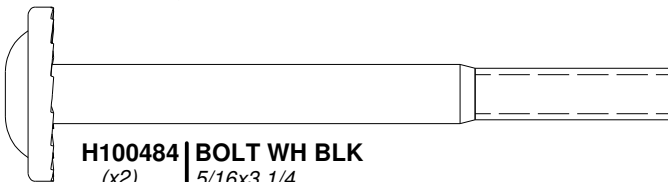

H100484 | BOLT WH BLK
(x2) | 5/16x3 1/4

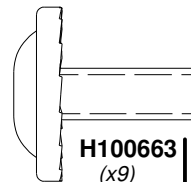

H100663 | BOLT WH BLK
(x9) | 5/16x3/4



H100416 | BOLT WH BLK
(x6) | 5/16x3

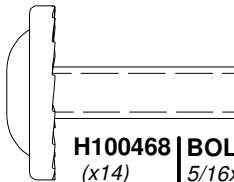

H100468 | BOLT WH BLK
(x14) | 5/16x1

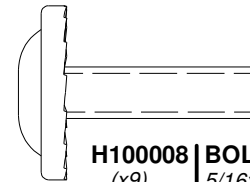

H100008 | BOLT WH
(x9) | 5/16x1

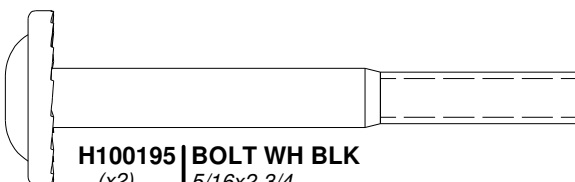

H100195 | BOLT WH BLK
(x2) | 5/16x2-3/4

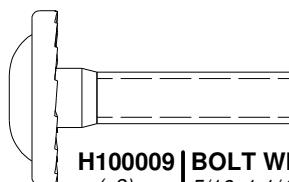

H100009 | BOLT WH
(x9) | 5/16x1 1/4

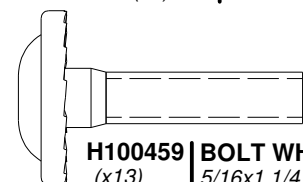

H100459 | BOLT WH BLK
(x13) | 5/16x1 1/4

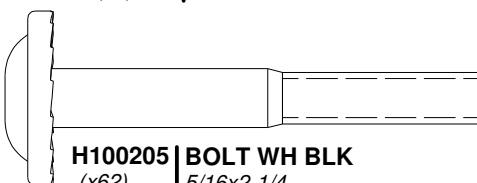

H100205 | BOLT WH BLK
(x62) | 5/16x2-1/4

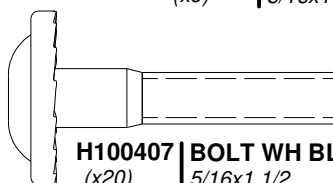

H100407 | BOLT WH BLK
(x20) | 5/16x1 1/2

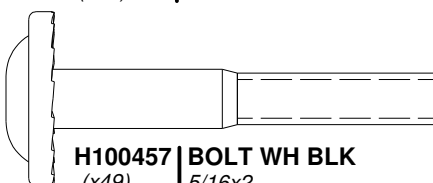

H100457 | BOLT WH BLK
(x49) | 5/16x2

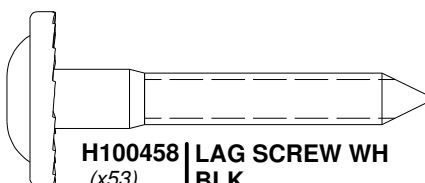

**H100458 | LAG SCREW WH
BLK**
(x53) | 5/16x2

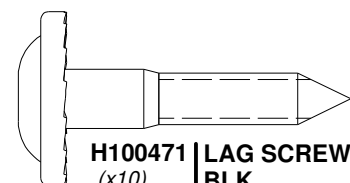

**H100471 | LAG SCREW WH
BLK**
(x10) | 5/16x1 1/2

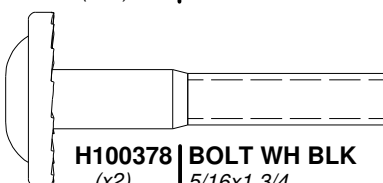

H100378 | BOLT WH BLK
(x2) | 5/16x1 3/4

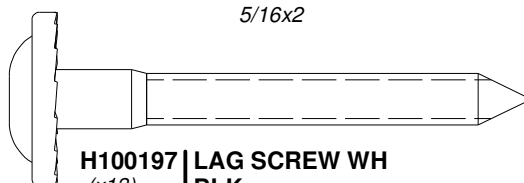

**H100197 | LAG SCREW WH
BLK**
(x13) | 5/16x2 1/2

Owner's Manual - Parts Identification

Hardware Components

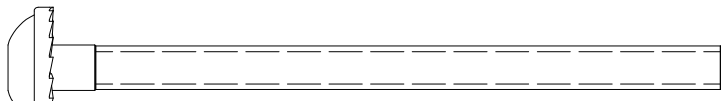

H101127 | BOLT WH BLK
(x4) | 1/4x3 1/2

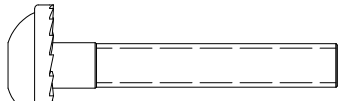

H100406 | BOLT WH BLK
(x4) | 1/4x1 1/2

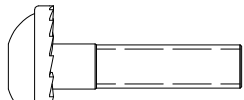

H100171 | BOLT WH BLK
(x9) | 1/4x1



H100456 | LAG SCREW WH BLK
(x6) | 1/4x2 1/2

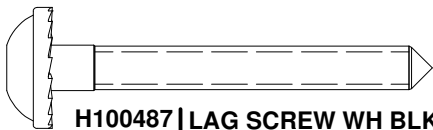

H100487 | LAG SCREW WH BLK
(x2) | 1/4x2

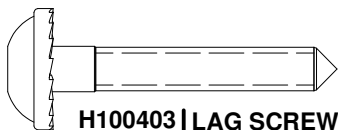

H100403 | LAG SCREW WH BLK
(x13) | 1/4x1 1/2

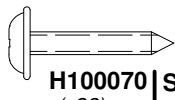

H100070 | SCREW PWH
(x22) | 8x3/4

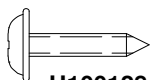

H100128 | SCREW PWH
(x9) | 8x5/8

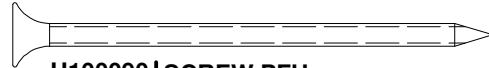

H100090 | SCREW PFH
(x48) | 8x2 1/2"

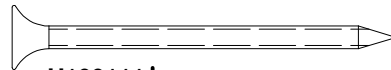

H100111 | SCREW PFH
(x13) | 8x2

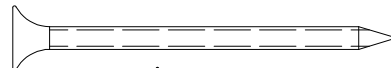

H100391 | SCREW PFH BLK
(x52) | 8x2

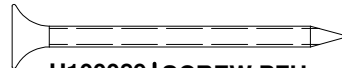

H100089 | SCREW PFH
(x65) | 8x1 3/4

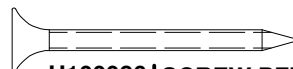

H100086 | SCREW PFH
(x280) | 8x1 1/2

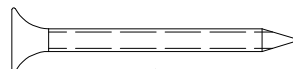

H100200 | SCREW PFH BLK
(x2) | 8x1 1/2



H100387 | SCREW PFH BLK
(x22) | 8x1-1/4

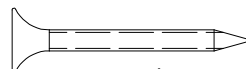

H100087 | SCREW PFH
(x134) | 8x1 1/4

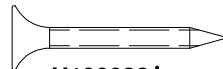

H100088 | SCREW PFH
(x250) | 8x1 1/8

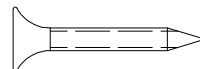

H100085 | SCREW PFH
(x26) | 8x1

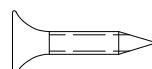

H100121 | SCREW PFH
(x7) | 8x3/4

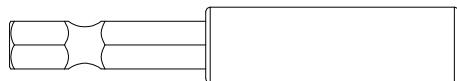

H101100 | MAGNETIC DRIVER
(x1)

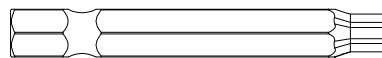

H100147 | T-30 TORX BIT
(x1)

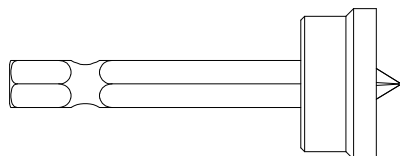

H100764 | SCREW SETTER
(x1)

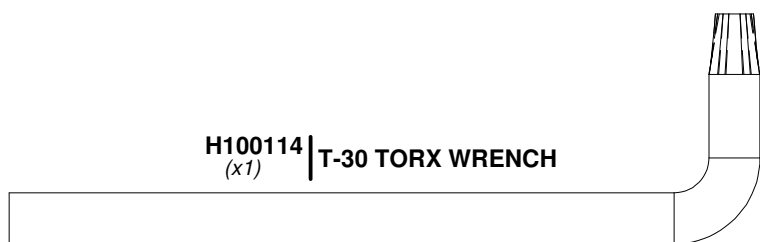

H100114 | T-30 TORX WRENCH
(x1)

Owner's Manual - Parts Identification

Hardware Components



H100006 | NUT BARREL WH
(x9) | 5/16x1 1/2

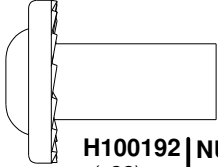

H100192 | NUT BARREL WH BLK
(x22) | 5/16x7/8

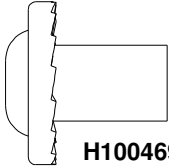

H100469 | NUT BARREL WH BLK
(x2) | 5/16x5/8

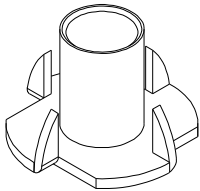

H100073 | T-NUT
(x13) | 3/8

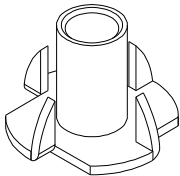

H100379 | T-NUT BLK
(x172) | 5/16

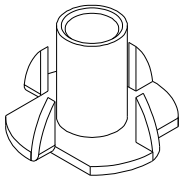

H100074 | T-NUT
(x20) | 5/16

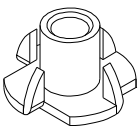

H100398 | T-NUT BLK
(x18) | 1/4

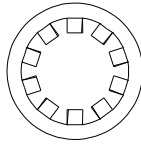

H100107 | WASHER LOCK
(x13) | INT
10x18

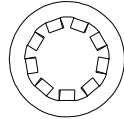

H100473 | WASHER LOCK
(x2) | INT BLK
8x15

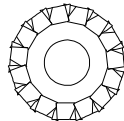

H100405 | WASHER LOCK
(x34) | EXT BLK
6x15

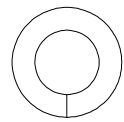

H100477 | WASHER SPLIT
(x4) | BLK
5/16

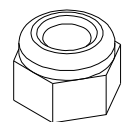

H100479 | NUT LOCK BLK
(x2) | 5/16

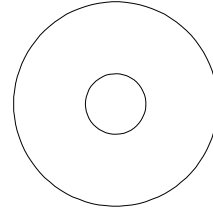

H100478 | WASHER FLAT
(x4) | BLK
8x27

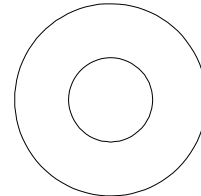

H100102 | WASHER FLAT
(x13) | 11x25

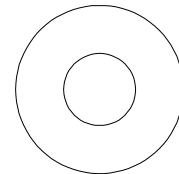

H100770 | WASHER FLAT
(x4) | BLK
5/16

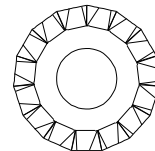

H100198 | WASHER LOCK
(x215) | EXT BLK
8x19

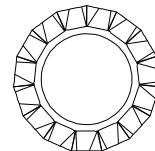

H100199 | WASHER LOCK
(x10) | EXT BLK
12x19

Owner's Manual - Parts Identification

Accessory Components (Not to Scale)



A100047 | CHAIN GREEN 57"
(x4)

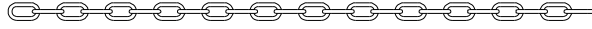

A100177 | CHAIN GREEN 31"
(x2)

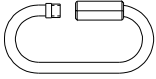

A100069 | QUICK LINK
(x6)



A100134 | HAND GRIP GREEN 816 C/C
(x2)

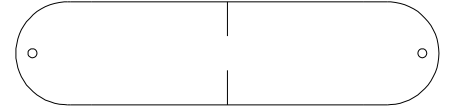

A6P00054 | SWING SEAT GREEN 22"
(x2)

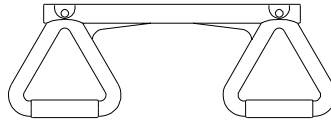

A6P00034 | TRAPEZE YELLOW
(x1)

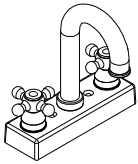

A6P00024 | FAUCET KIT
(x1)

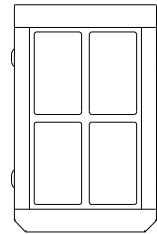

A6P00019 | WINDOW (FLAT PACK)
(x1)

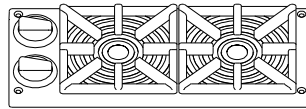

A6P00025 | STOVE KIT
(x1)

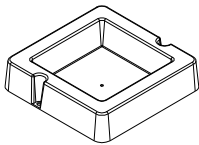

A6P00032 | SURFACE MOUNT BASIN
(x1)

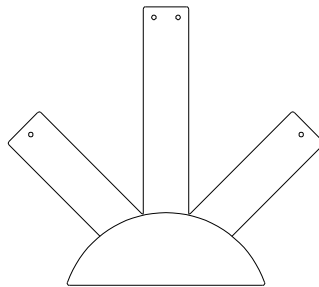

A100361 | PLASTIC SUNBURST
(x4)

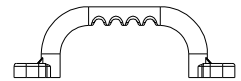

A6P00303 | HAND GRIP YELLOW
(x4)

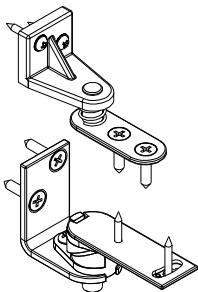

A4M00642 | SALOON DOOR HINGE KIT
(x2)



A100178 | AUGER GROUND STAKE
(x8)

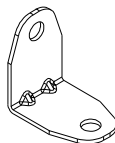

A4M01047 | L BRACKET 2.5x38x55x55
(x17)

Owner's Manual - Parts Identification

Accessory Components (Not to Scale)



A100164 | **BYD ID TAG**
(x1) | **(LARGE) AGES**
3-10

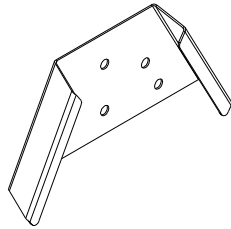

A4M01169 | **A-FRAME BRACKET**
(x1)

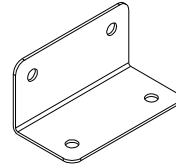

A100140 | **L BRACKET 66x66x127**
(x2)

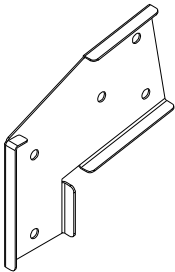

A100325 | **SWING BEAM**
(x1) | **EXTENSION**
BRACKET-LEFT

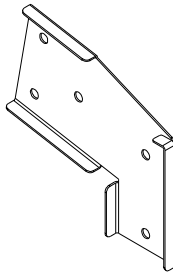

A100326 | **SWING BEAM**
(x1) | **EXTENSION**
BRACKET-RIGHT

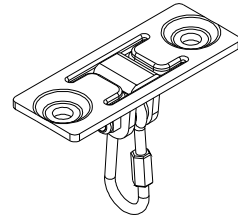

A4M00505 | **SWING HANGER**
(x6)

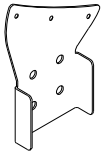

A4M01091 | **60" SLIDE**
(x1) | **BRACE (RIGHT)**

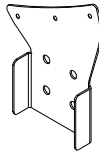

A4M01092 | **60" SLIDE**
(x1) | **BRACE (LEFT)**

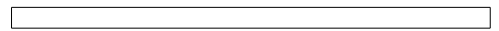

A6P00487 | **SLIDE TUBE SUPPORT**
(x4)

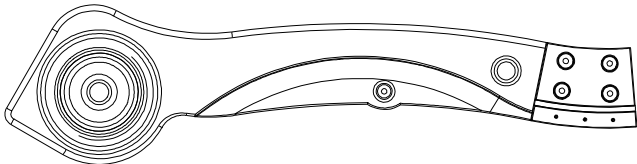

A6P00484 | **SLIDE RAIL 10' BOTTOM RIGHT GREEN**
(x1)

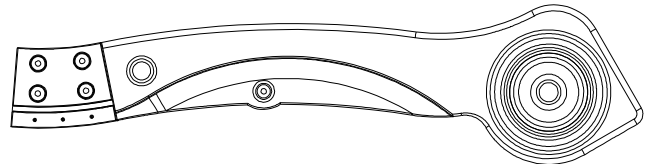

A6P00483 | **SLIDE RAIL 10' BOTTOM LEFT GREEN**
(x1)

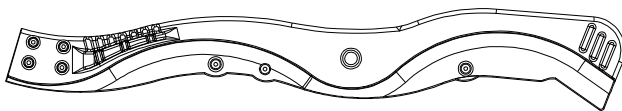

A6P00486 | **SLIDE RAIL 10' TOP RIGHT GREEN**
(x1)

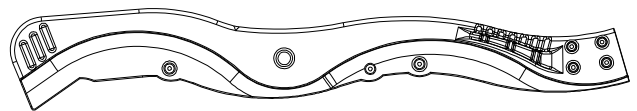

A6P00485 | **SLIDE RAIL 10' TOP LEFT GREEN**
(x1)

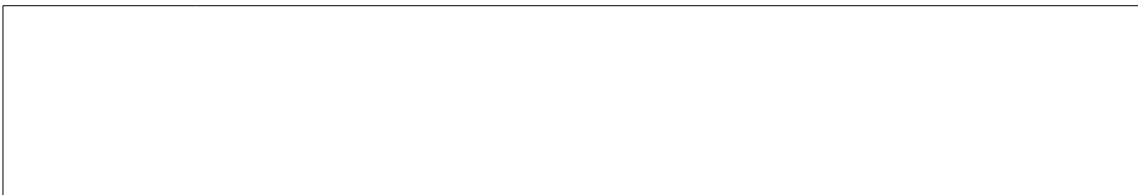

A100197 | **SLIDE BED 10' YELLOW**
(x1)

PRE-ASSEMBLY STEP 1 - SORTING PARTS

It is critical for ease of assembly that you take the time to sort and organize the wood and hardware.

WOOD PARTS:

- Organize wood parts by the three-digit, alpha-numeric number stamped on each board (ex. P01).
- If there are multiple boards with the same stamped number, stack those pieces together.
- Stamps can be found on the flat surface of the boards or on the end of the boards.
- Allow yourself plenty of room - the wood pieces can take up a significant amount of space.

NOTE: CARTONS ARE NOT ORGANIZED BY BOARD NUMBER.

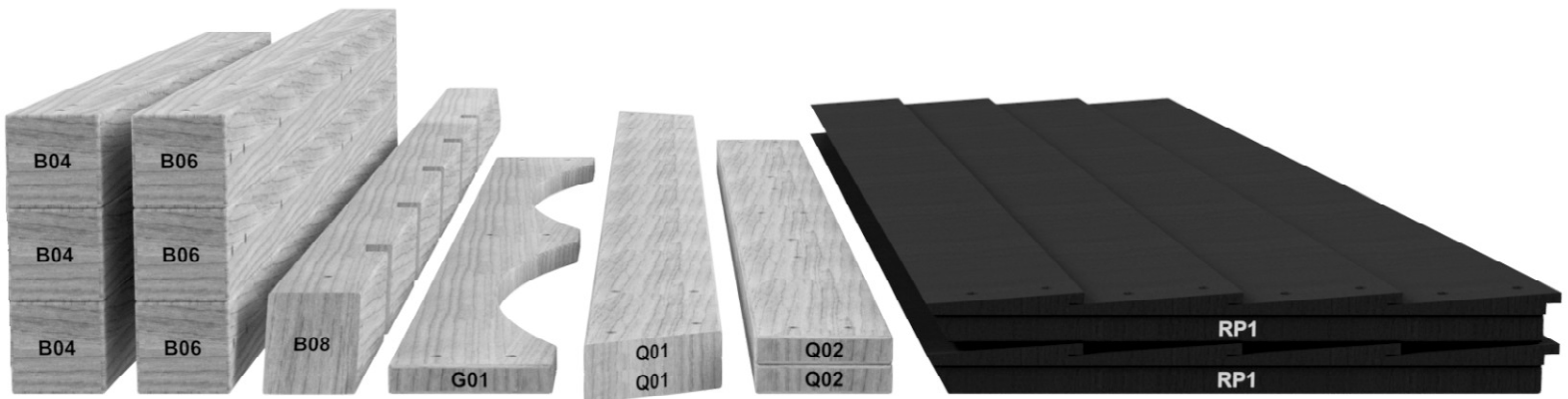

HARDWARE PARTS:

- We recommend that you have a separate table to organize the hardware.
- Hardware bags are printed with a seven-digit, alpha-numeric part number.
- You can organize your hardware by part number or group by hardware type (i.e. bolts, nuts, etc.).
- During assembly you only need to reference the last four digits of the number.

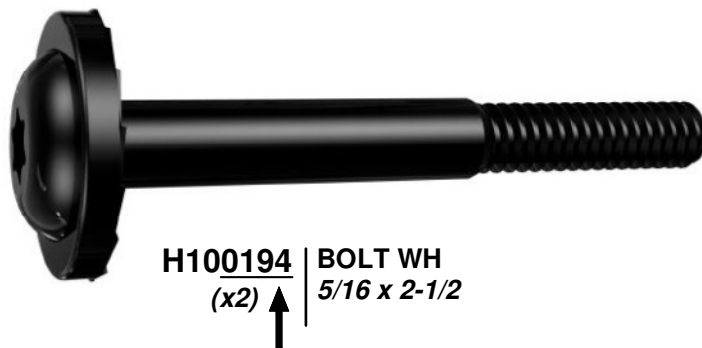

PRE-ASSEMBLY STEP 2 - TOOLS REQUIRED



**Cordless Drill or
Electric Drill**



**Drill Attachments:
Phillips Head**



**1/8", 3/16", 3/8" & 7/16"
Drill Bits**



Phillips Screw Driver



Open End Wrenches 1/2" & 9/16"



**3/8" Drive Ratchet, 1/2" &
9/16" STD Sockets 1/2" & 9/16" Deep
Sockets**



Claw Hammer



Rubber Mallet - Optional



Tape Measure

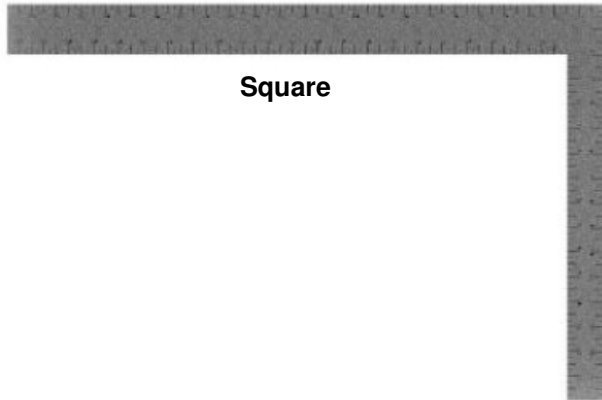

Square



Level 24"

PRE-ASSEMBLY STEP 3 - CHOOSE YOUR ASSEMBLY METHOD

There are several types of assembly instructions available to you.

1. Printed Assembly Manual included with your set
2. BILT APP - 3D interactive instructions
3. Combination of the Printed Manual and BILT APP (Note: Step numbers can differ between the two methods)

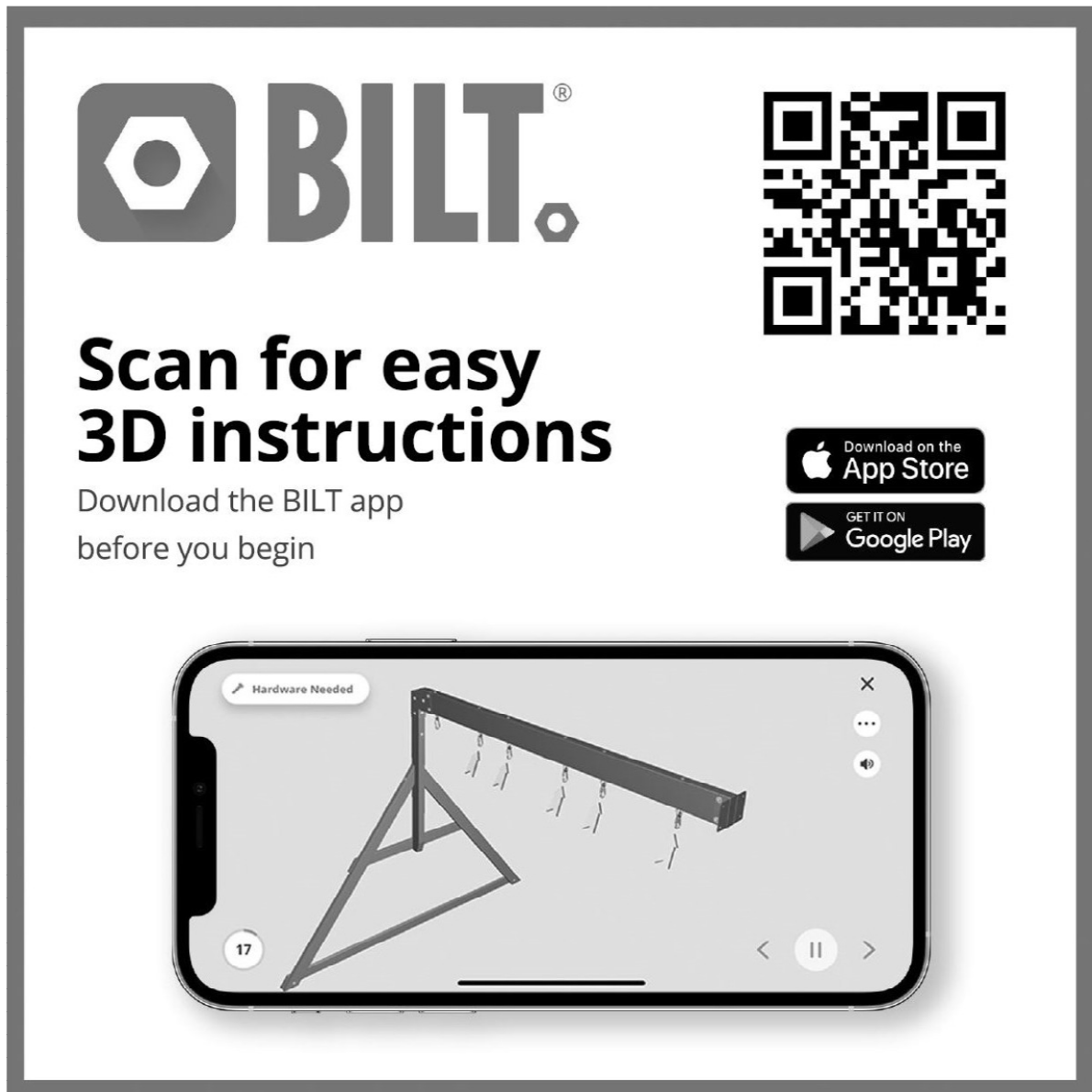

BILT.[®]

Scan for easy
3D instructions

Download the BILT app
before you begin

Download on the
App Store

GET IT ON
Google Play

Hardware Needed

17

< || >

STEP 1 - LADDER ASSEMBLY

QTY	PART NUMBER	DESCRIPTION
6	H100391	SCREW PFH 8x2 BLK

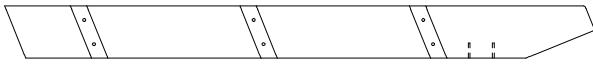

H79 | LEFT UPRIGHT - W4L06611
(x1) | 1"x3 3/8"x38 3/8" (24x86x976)

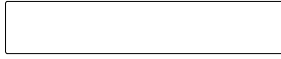

H76 | LADDER RUNG - W4L06609
(x3) | 1"x3 3/8"x18 1/8" (24x86x460)

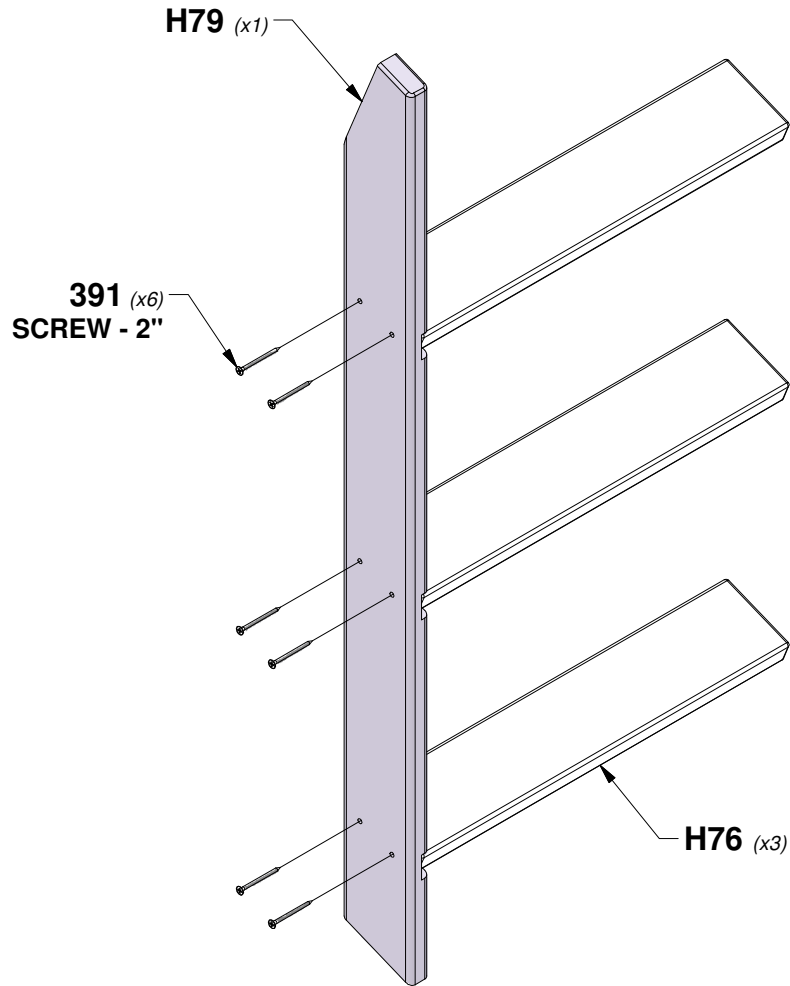

STEP 2 - LADDER ASSEMBLY

QTY	PART NUMBER	DESCRIPTION
6	H100391	SCREW PFH 8x2 BLK

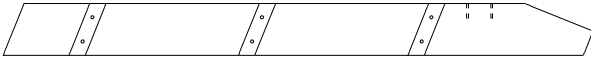

H75 | RIGHT UPRIGHT - W4L16916
(x1) | 1"x3 3/8"x38 3/8" (24x86x976)

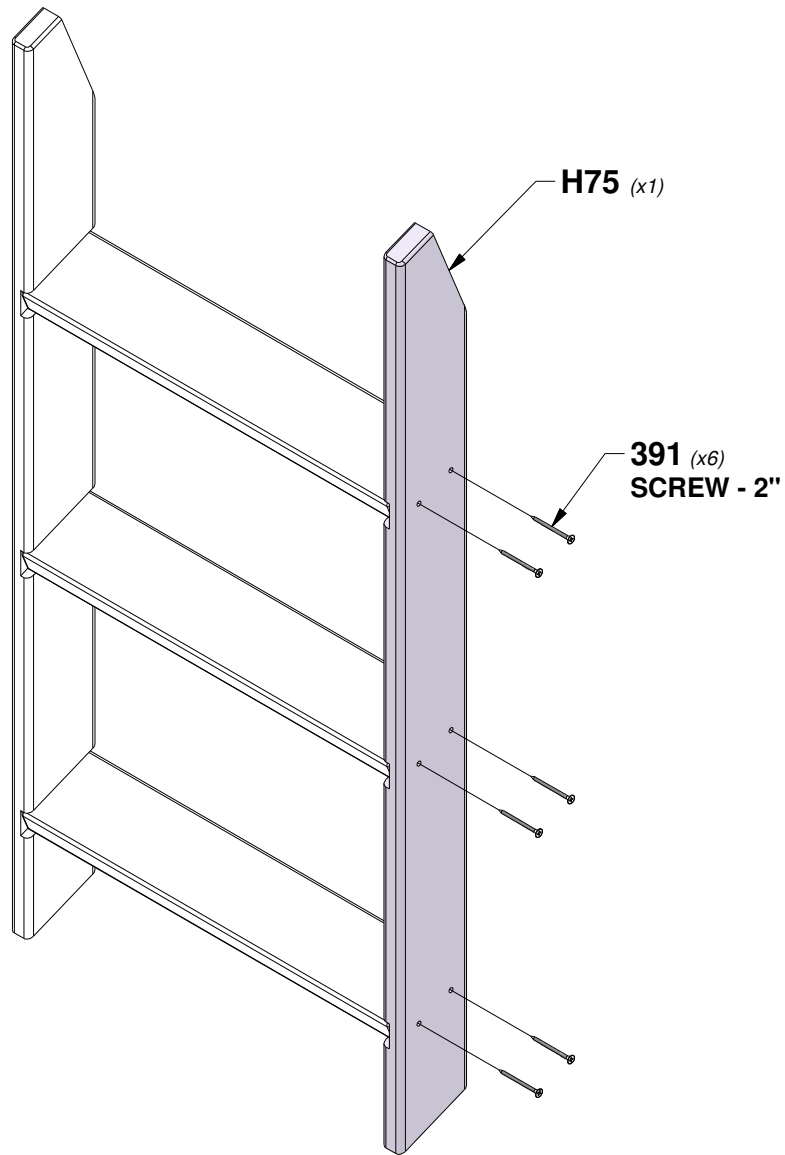

STEP 3 - LADDER ASSEMBLY

QTY	PART NUMBER	DESCRIPTION
4	H100391	SCREW PFH 8x2 BLK



M73 | REAR SUPPORT - W4L06608
(x1) | 5/8"x3 3/8"x19 1/4" (16x86x488)

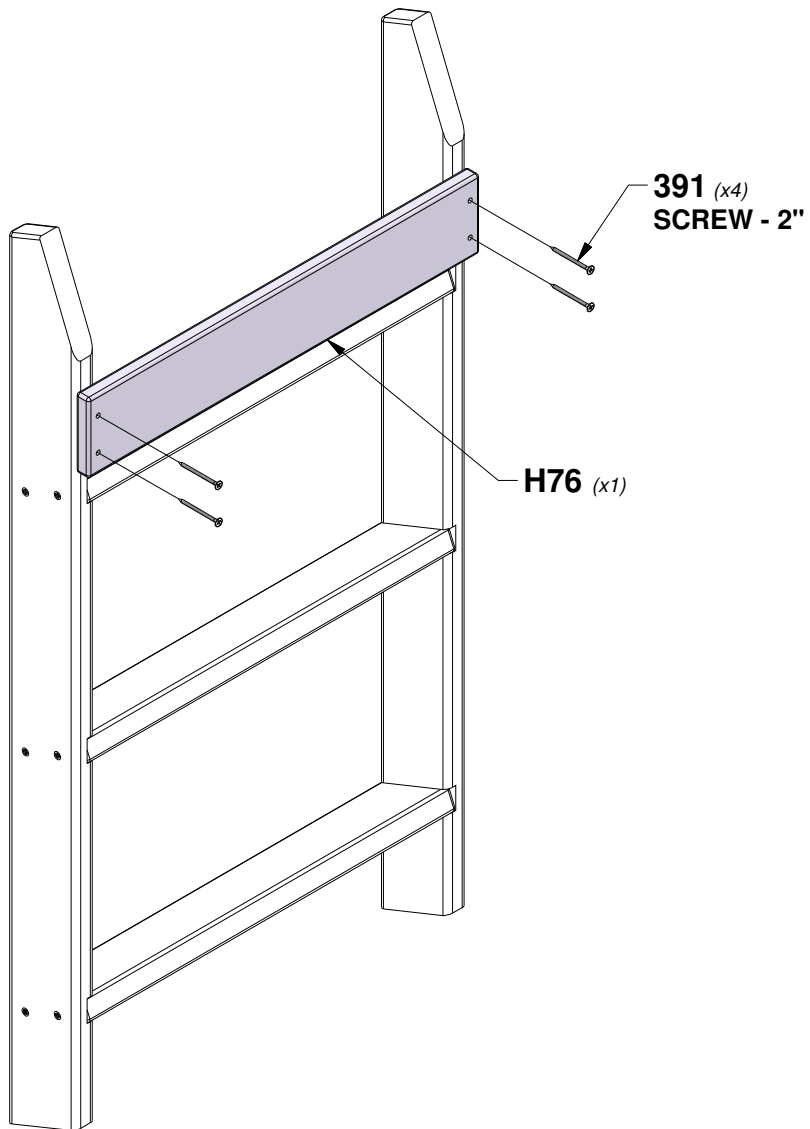

STEP 4 - LADDER ASSEMBLY

QTY	PART NUMBER	DESCRIPTION
4	H100391	SCREW PFH 8x2 BLK



H16 | ATTACHMENT BOARD - W4L16846
(x1) | 1"x3 3/8"x19 1/4" (24x86x488)

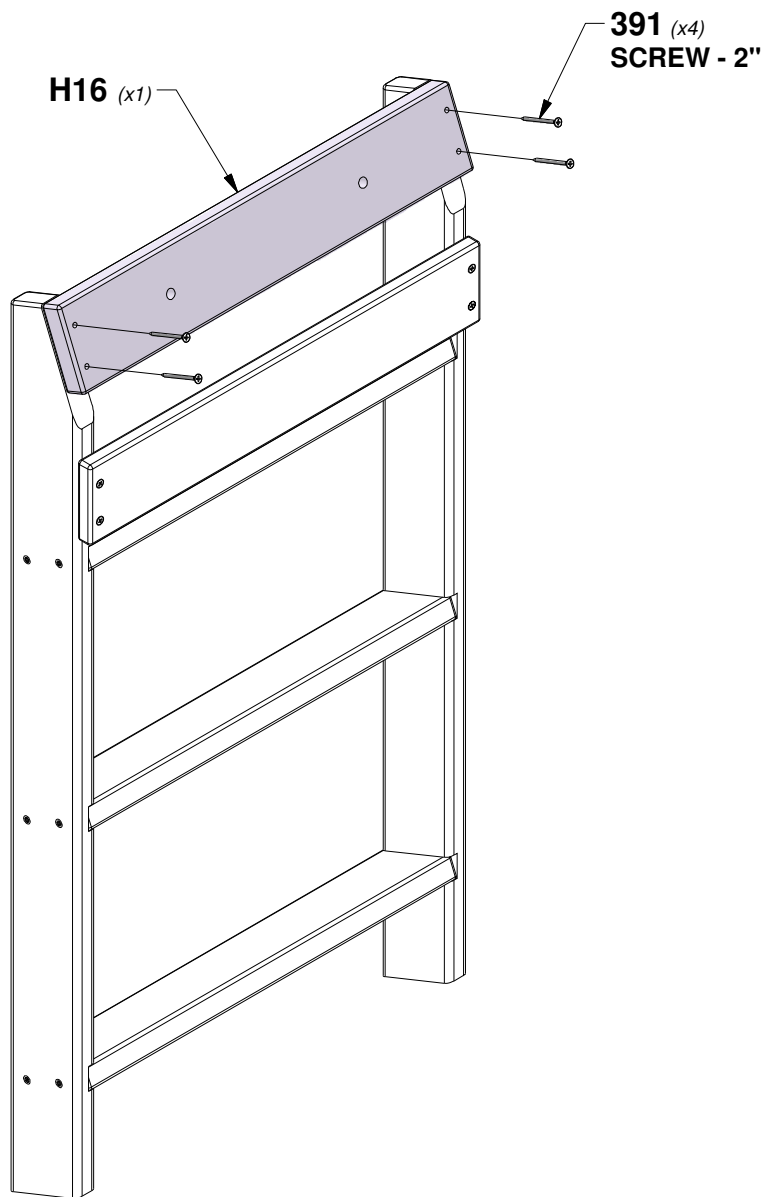

STEP 1 - LADDER ASSEMBLY

QTY	PART NUMBER	DESCRIPTION
10	H100391	SCREW PFH 8x2 BLK

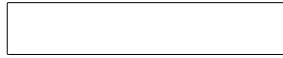

H76 | LADDER RUNG - W4L06609
(x5) | 1"x3 3/8"x18 1/8" (24x86x460)

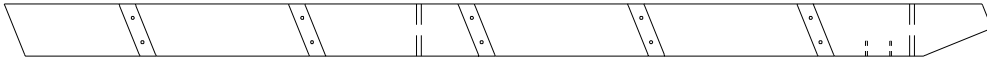

H77 | LEFT UPRIGHT - W4L16847
(x1) | 1"x3 3/8"x64 3/8" (24x86x1634)

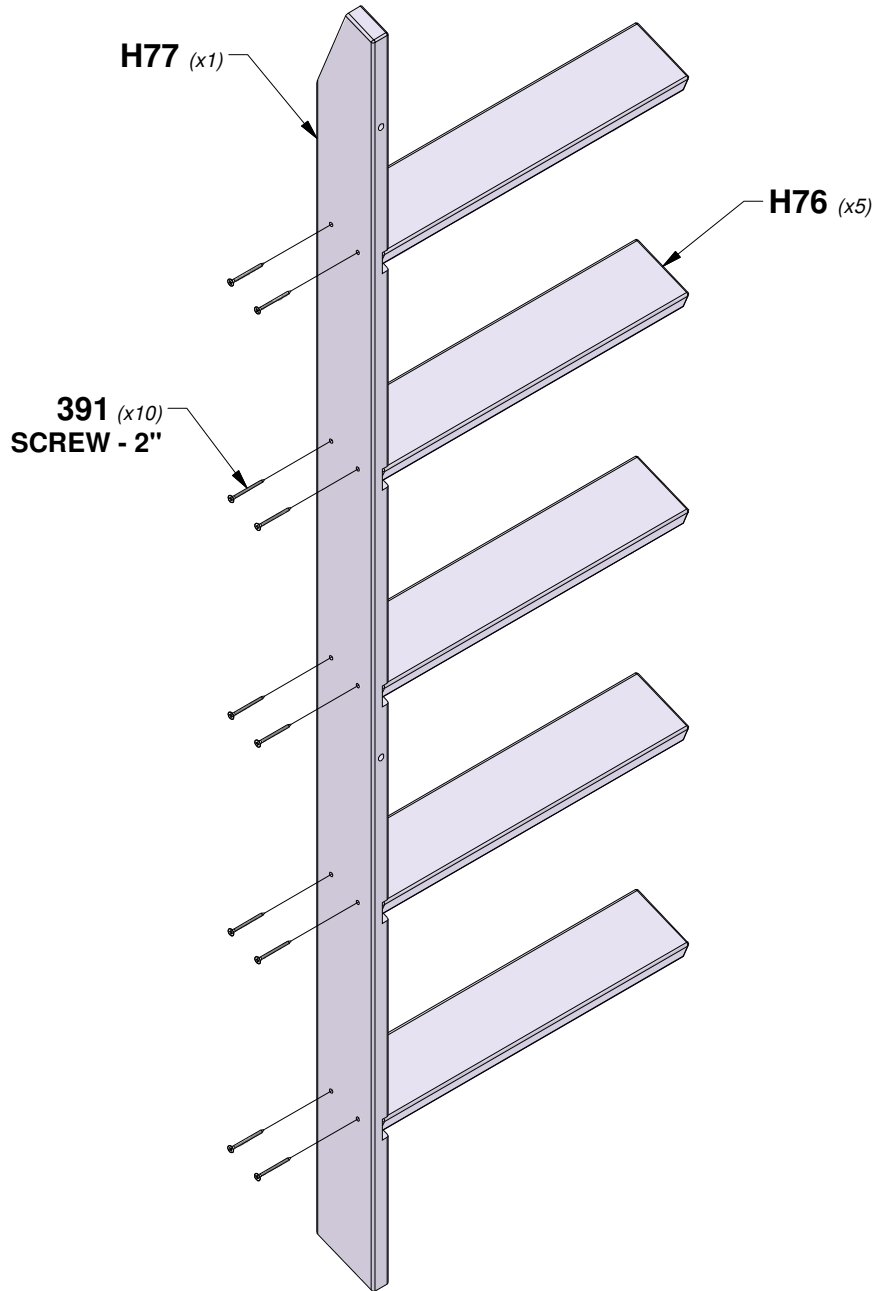

STEP 2 - LADDER ASSEMBLY

QTY	PART NUMBER	DESCRIPTION
10	H100391	SCREW PFH 8x2 BLK



H78 | LEFT UPRIGHT - W4L16848
(x1) | 1"x3 3/8"x64 3/8" (24x86x1634)

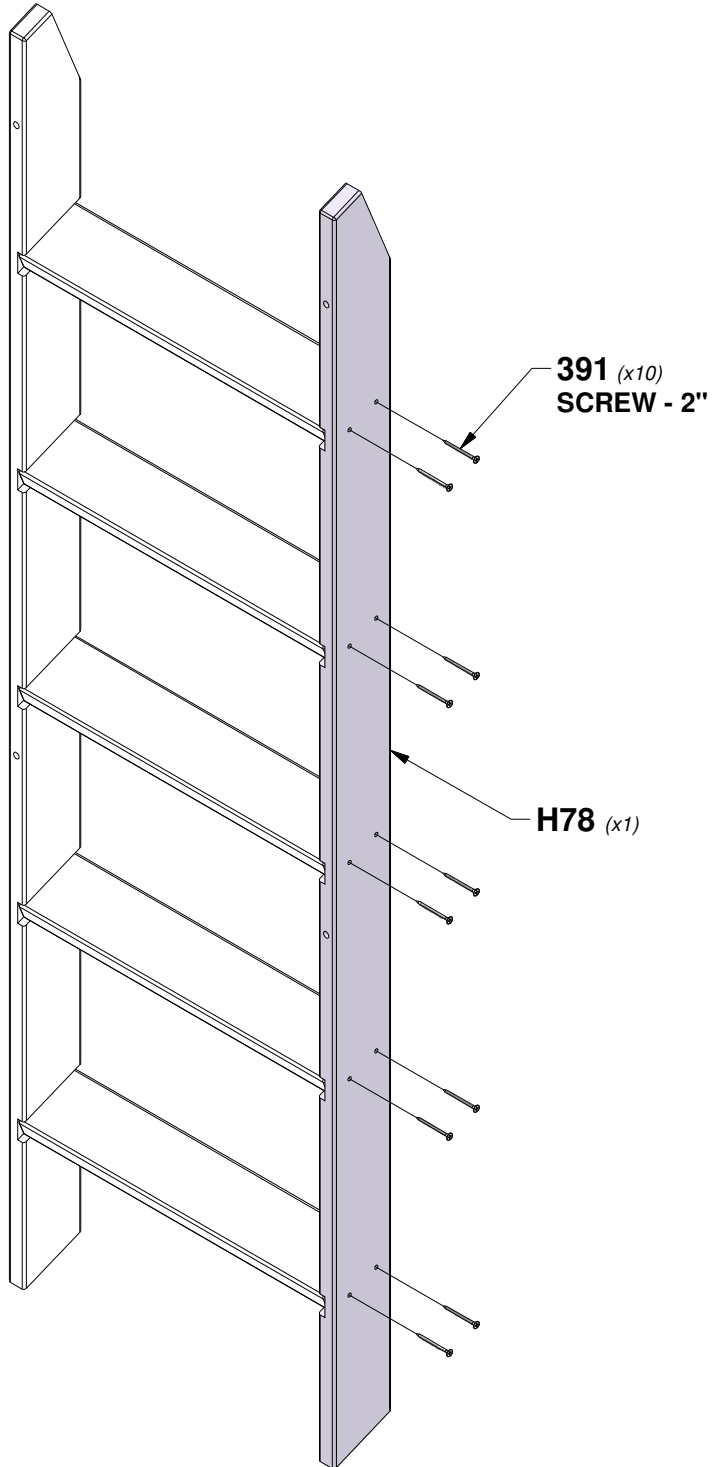

STEP 3 - LADDER ASSEMBLY

QTY	PART NUMBER	DESCRIPTION
8	H100391	SCREW PFH 8x2 BLK



M73 | REAR SUPPORT - W4L06608
(x1) | 5/8"x3 3/8"x19 1/4" (16x86x488)



H16 | ATTACHMENT BOARD - W4L16846
(x1) | 1"x3 3/8"x19 1/4" (24x86x488)

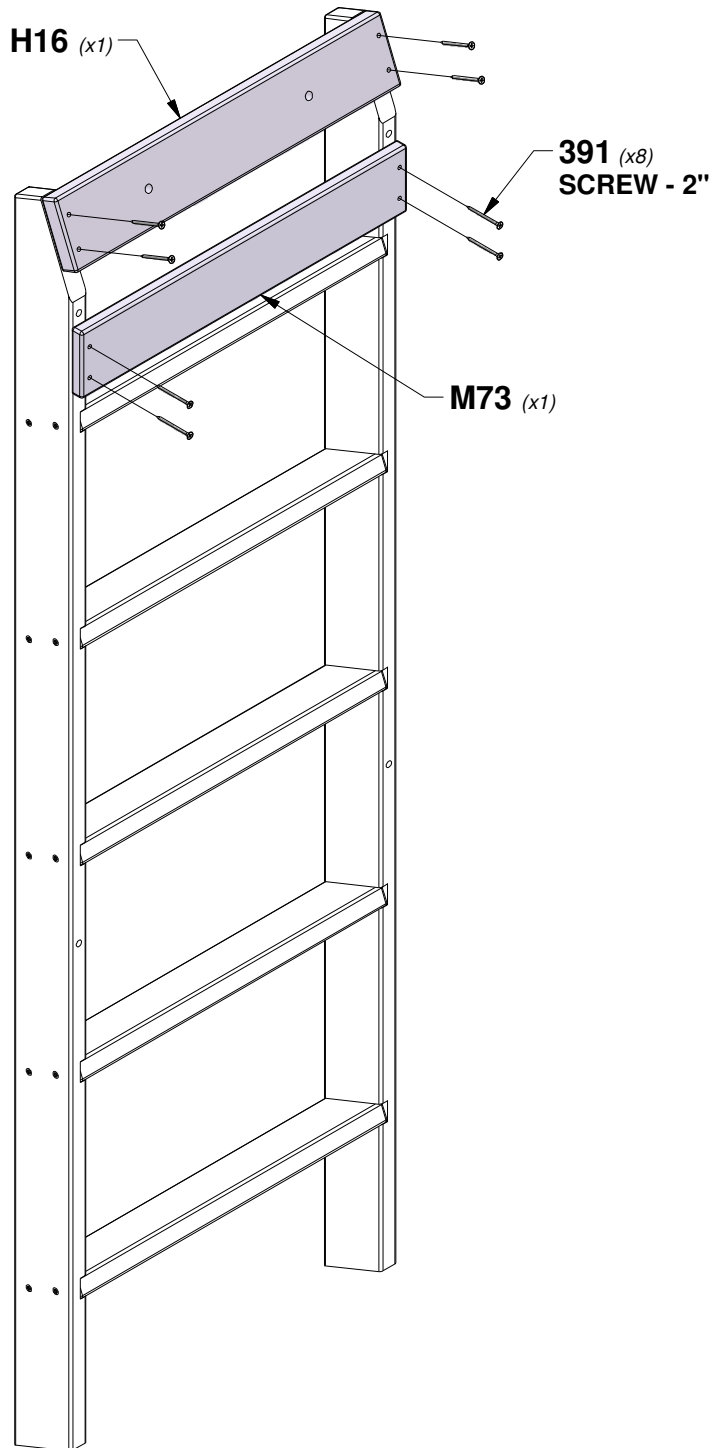

STEP 4 - LADDER ASSEMBLY

QTY	PART NUMBER	DESCRIPTION
4	H101127	BOLT WH 1/4x3 1/2
4	H100398	T-NUT 1/4

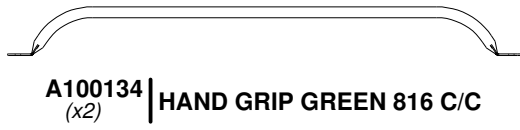

TIP:
INSTALL T-NUTS IN WOOD FIRST

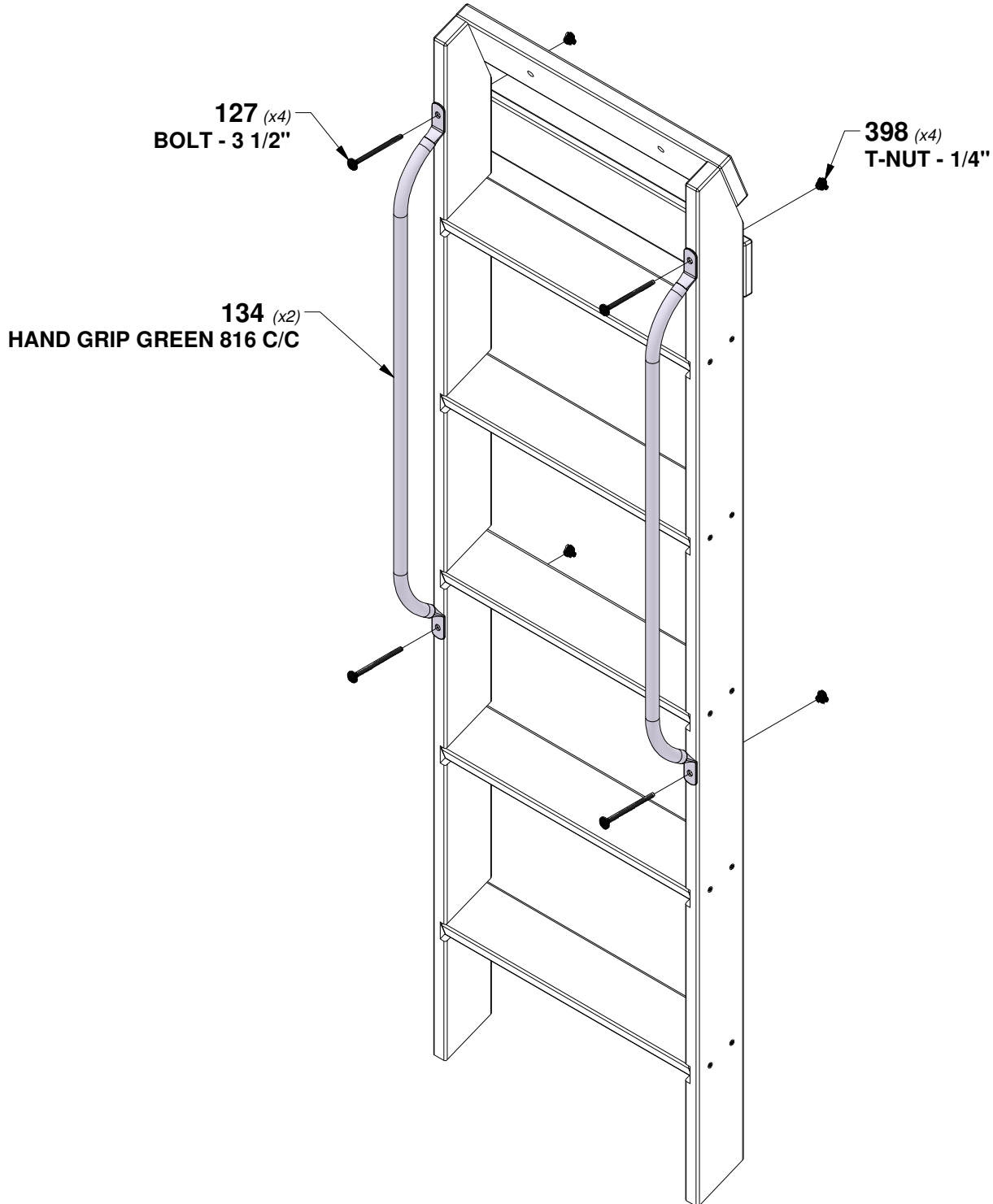

STEP 1 - SWING BEAM ASSEMBLY



A50 | SWING BEAM - W4L16822
(x1) | 3 3/8"x5 1/4"x89 1/2" (86x134x2274)

QTY	PART NUMBER	DESCRIPTION
3	H100192	NUT BARREL WH 5/16x7/8 BLK
3	H100416	BOLT WH 5/16x3 BLK
2	H100473	WASHER LOCK INT 8x15 BLK
2	H100476	BOLT HEX 5/16x4 1/4 BLK
2	H100479	NUT LOCK 5/16 BLK
4	H100770	WASHER FLAT 5/16 BLK

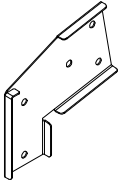

A100325 | SWING BEAM EXTENSION BRACKET-LEFT
(x1)

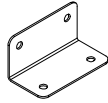

A100140 | L BRACKET
(x2) | 66x66x127

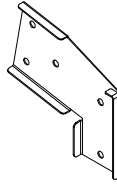

A100326 | SWING BEAM EXTENSION BRACKET-RIGHT
(x1)

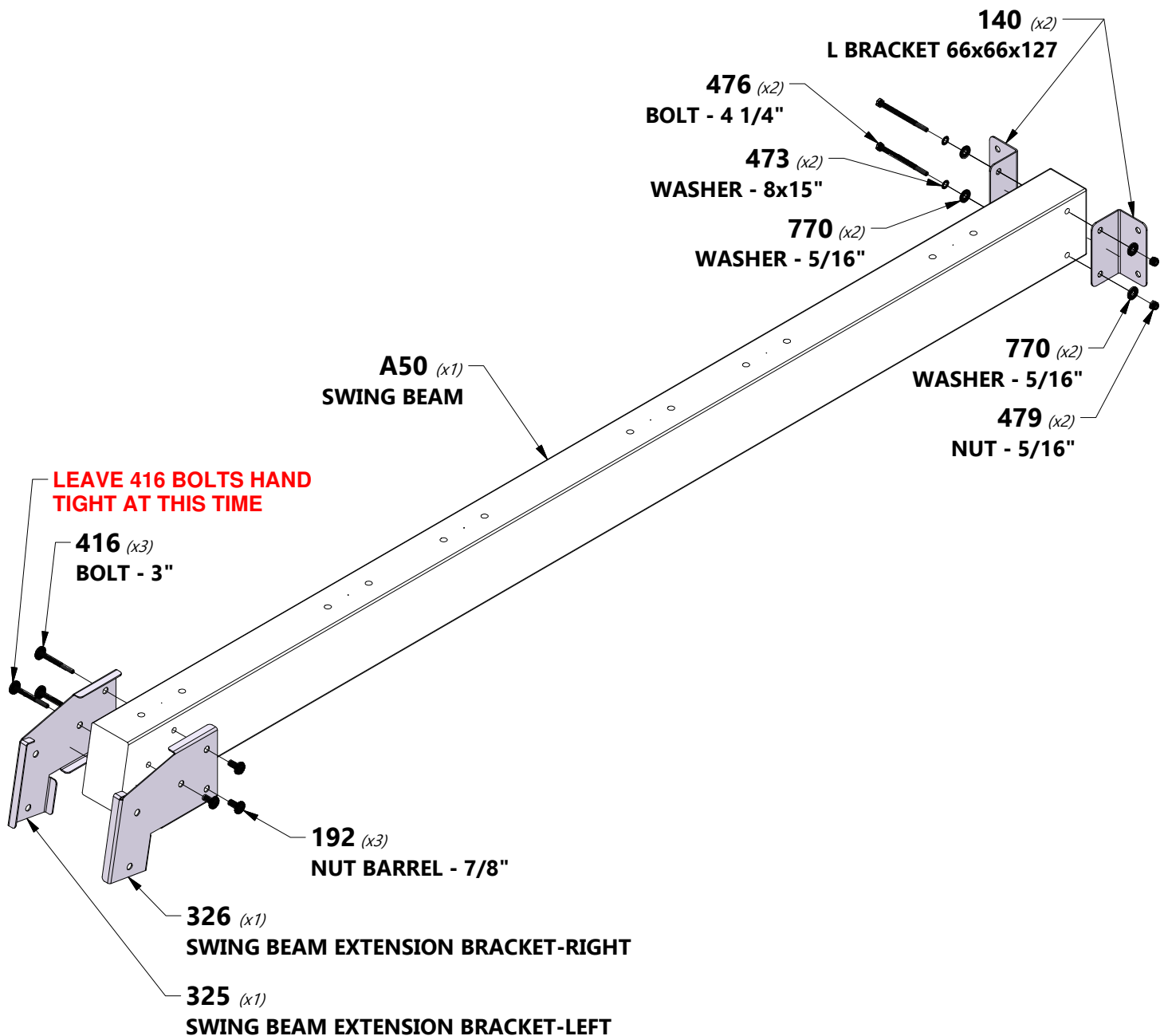

STEP 2 - SWING BEAM ASSEMBLY

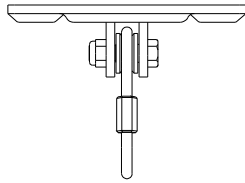

A4M00505
(x6) | **SWING HANGER**

QTY	PART NUMBER	DESCRIPTION
12	H100073	T-NUT 3/8
12	H100102	WASHER FLAT 11x25
12	H100107	WASHER LOCK INT 10x18
12	H100654	BOLT HEX 3/8x5-1/2

TIP:
INSTALL T-NUTS IN WOOD FIRST

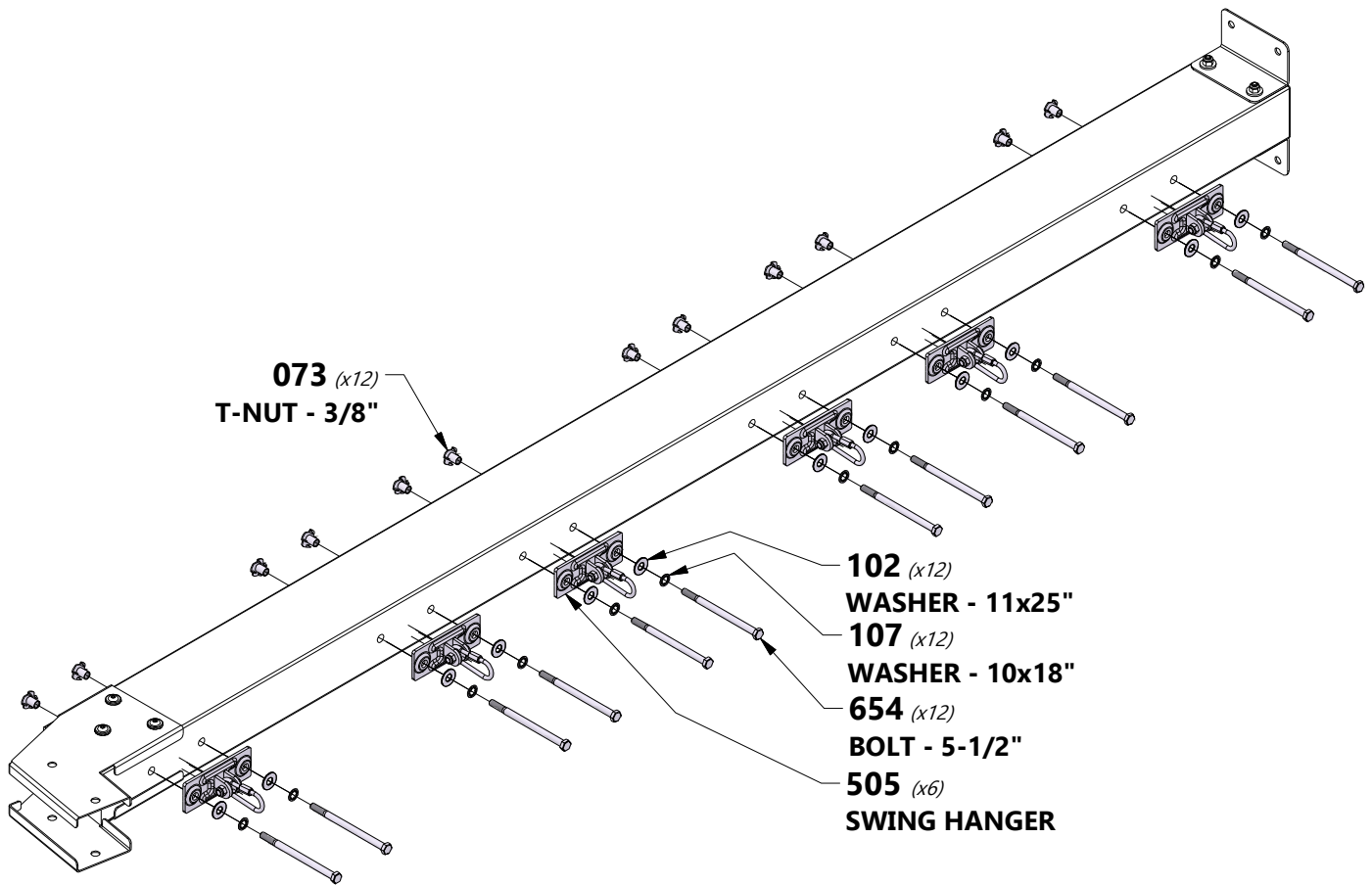

STEP 3 - SWING BEAM ASSEMBLY

QTY	PART NUMBER	DESCRIPTION
4	H100070	SCREW PWH 8x3/4



A100164 | BYD ID TAG
(x1)

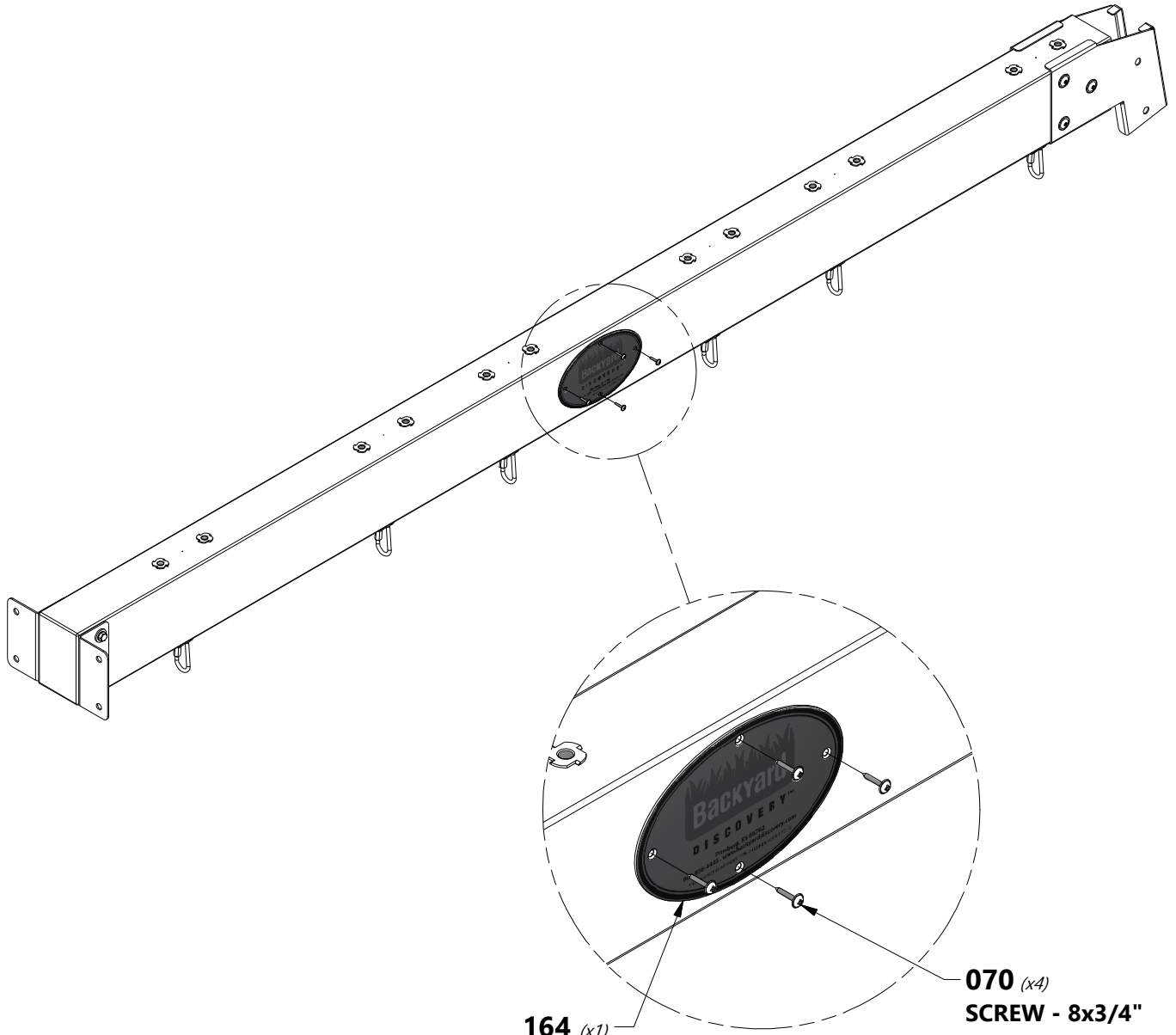

164 (x1)
BYD ID TAG (LARGE) AGES 3-10

070 (x4)
SCREW - 8x3/4"

STEP 4 - SWING BEAM ASSEMBLY

QTY	PART NUMBER	DESCRIPTION
6	H100379	T-NUT 5/16 BLK
4	H100407	BOLT WH 5/16x1 1/2 BLK
2	H100503	BOLT WH 5/16x3-1/2 BLK

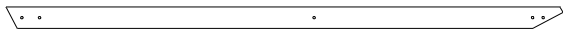

E80 | ANGLE BRACE - W4L16824
(x2) | 1 3/8"x3 3/8"x87 1/8" (36x86x2212)

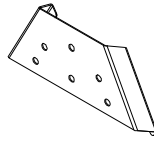

SP71 | SWING BEAM SUPPORT - W4L16823
(x1) | 3 3/8"x3 3/8"x49 1/2" (86x86x1256)

A4M01169 | A-FRAME BRACKET
(x1)

TIP:
INSTALL T-NUTS IN WOOD FIRST

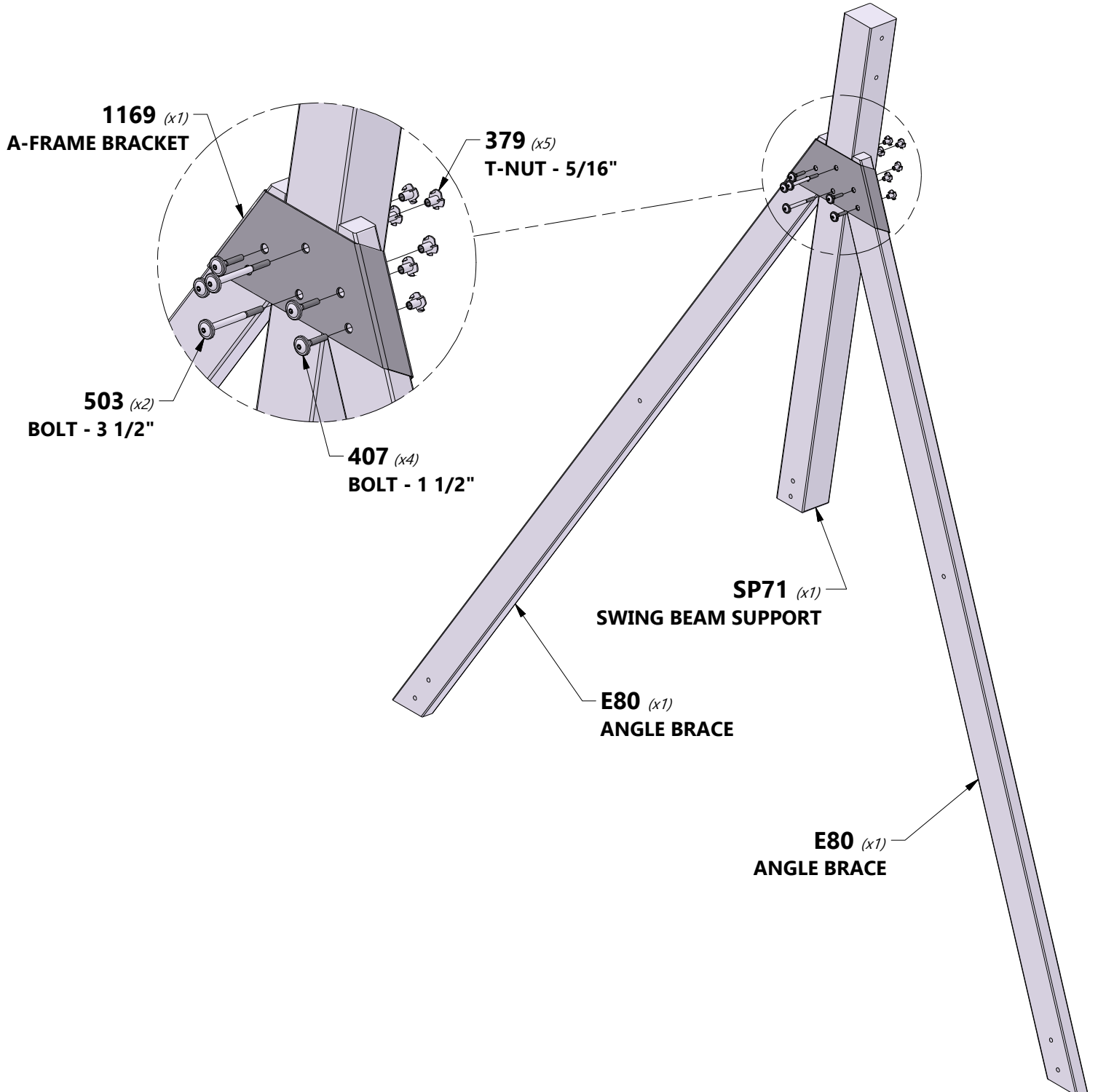

STEP 5 - SWING BEAM ASSEMBLY

E79 | END SUPPORT - W4L16825
 (x1) | 1 1/2"x3 1/2"x44" (36x86x1120)

G50 | GROUND BOARD - W4L16826
 (x1) | 1"x5 1/4"x86 11/16" (24x134x2202)

QTY	PART NUMBER	DESCRIPTION
2	H100195	BOLT WH 5/16x2-3/4 BLK
8	H100198	WASHER LOCK EXT 8x19 BLK
4	H100205	BOLT WH 5/16x2-1/4 BLK
8	H100379	T-NUT 5/16 BLK
2	H100480	BOLT WH 5/16x4 3/4 BLK

TIP:
 INSTALL T-NUTS IN WOOD FIRST

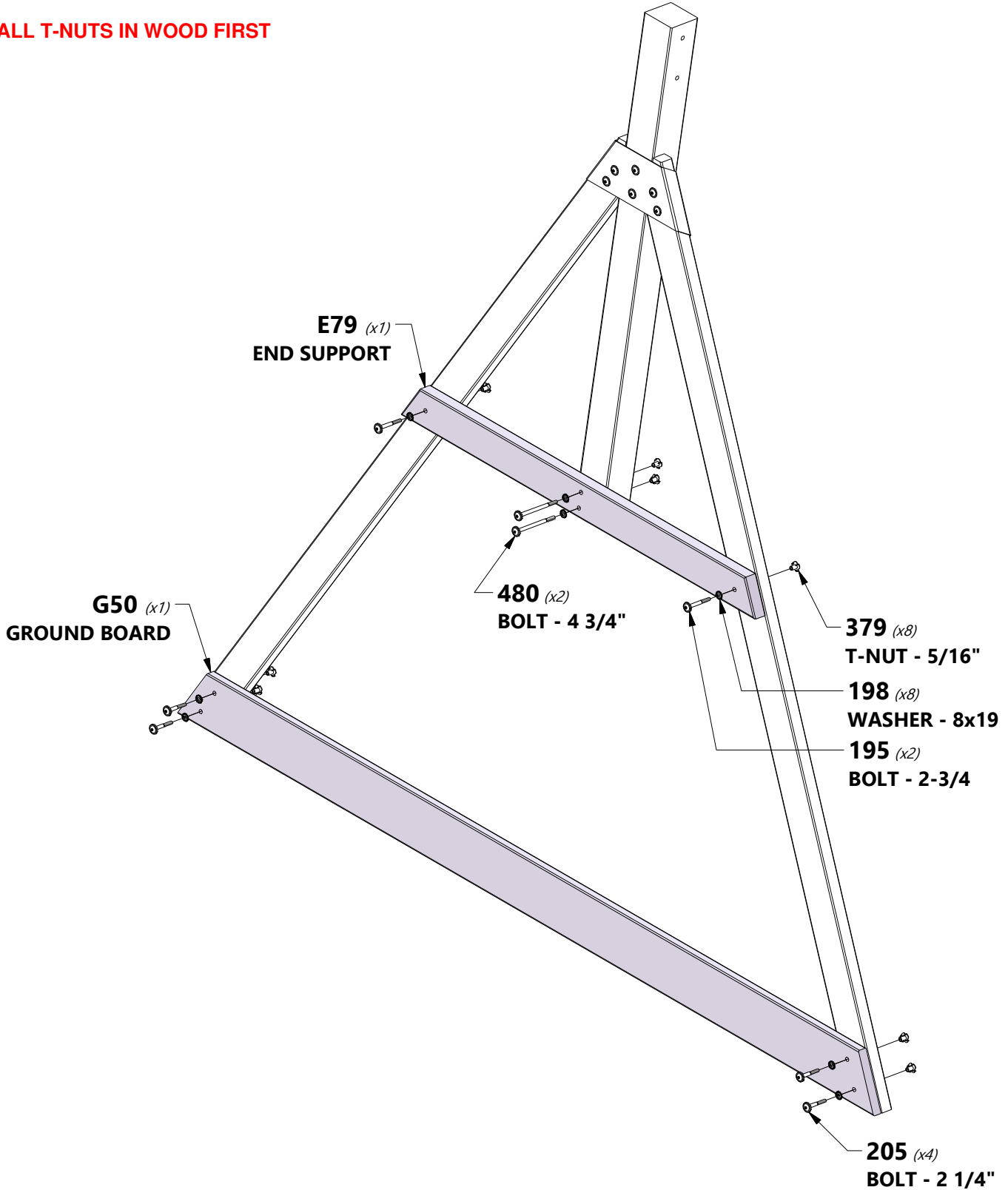

STEP 6 - SWING BEAM ASSEMBLY

QTY	PART NUMBER	DESCRIPTION
2	H100192	NUT BARREL WH 5/16x7/8 BLK
2	H100416	BOLT WH 5/16x3 BLK

FULLY TIGHTEN 416 BOLTS AT THIS TIME

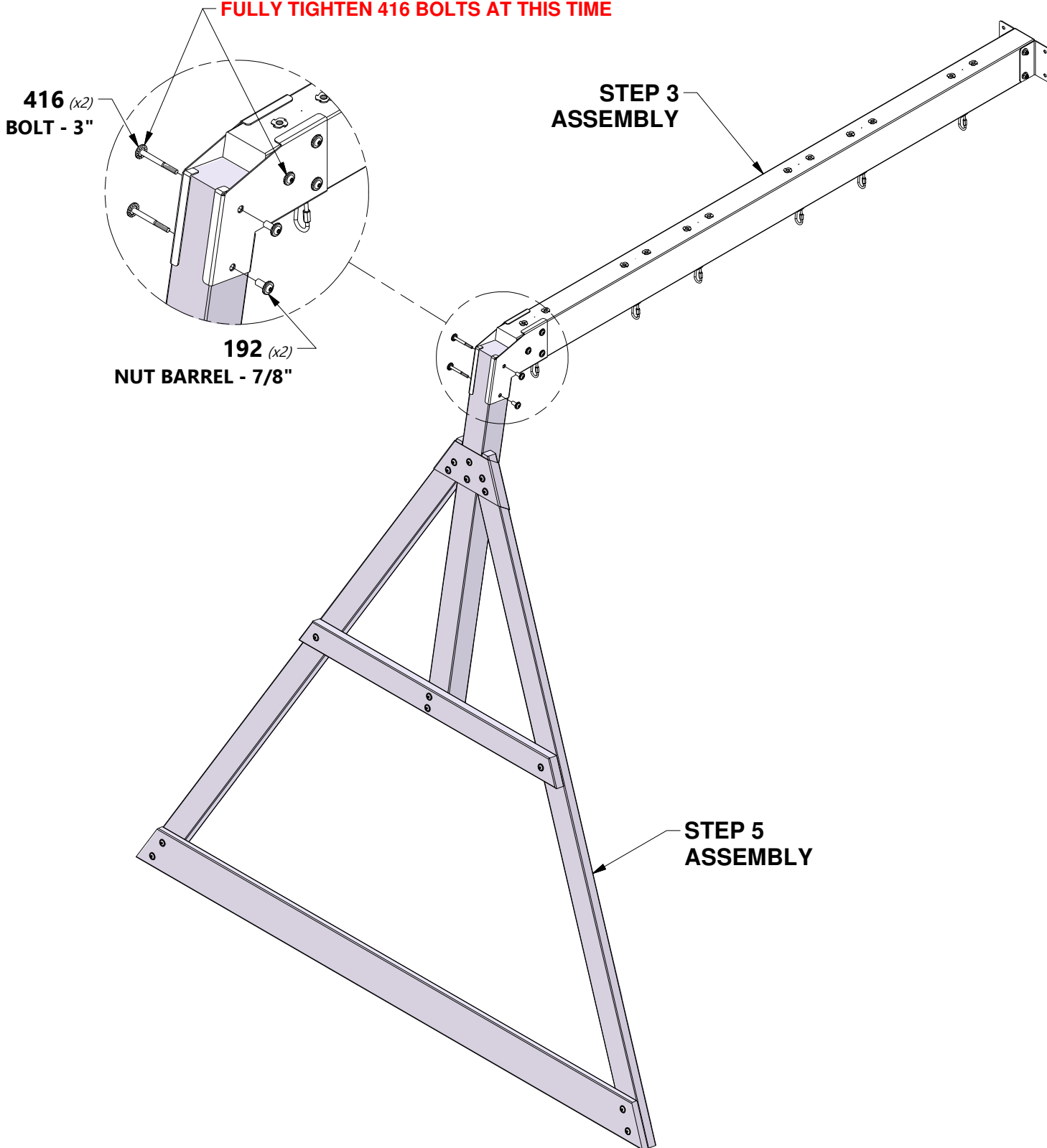

STEP 1 - FORT ASSEMBLY

QTY	PART NUMBER	DESCRIPTION
4	H100192	NUT BARREL WH 5/16x7/8 BLK
4	H100199	WASHER LOCK EXT 12x19 BLK
4	H100396	BOLT WH 5/16x1/2 BLK

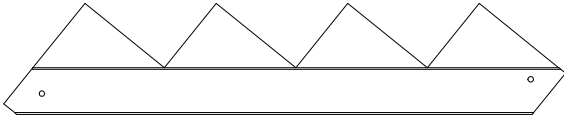

SR1 | STAIR STRINGER ASSEMBLY - W2A03486
 (x2) | 1"x8 1/8"x41" (24x205x1041)

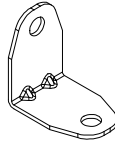

A4M01047 | L BRACKET
 (x4) | 2.5x38x55x55

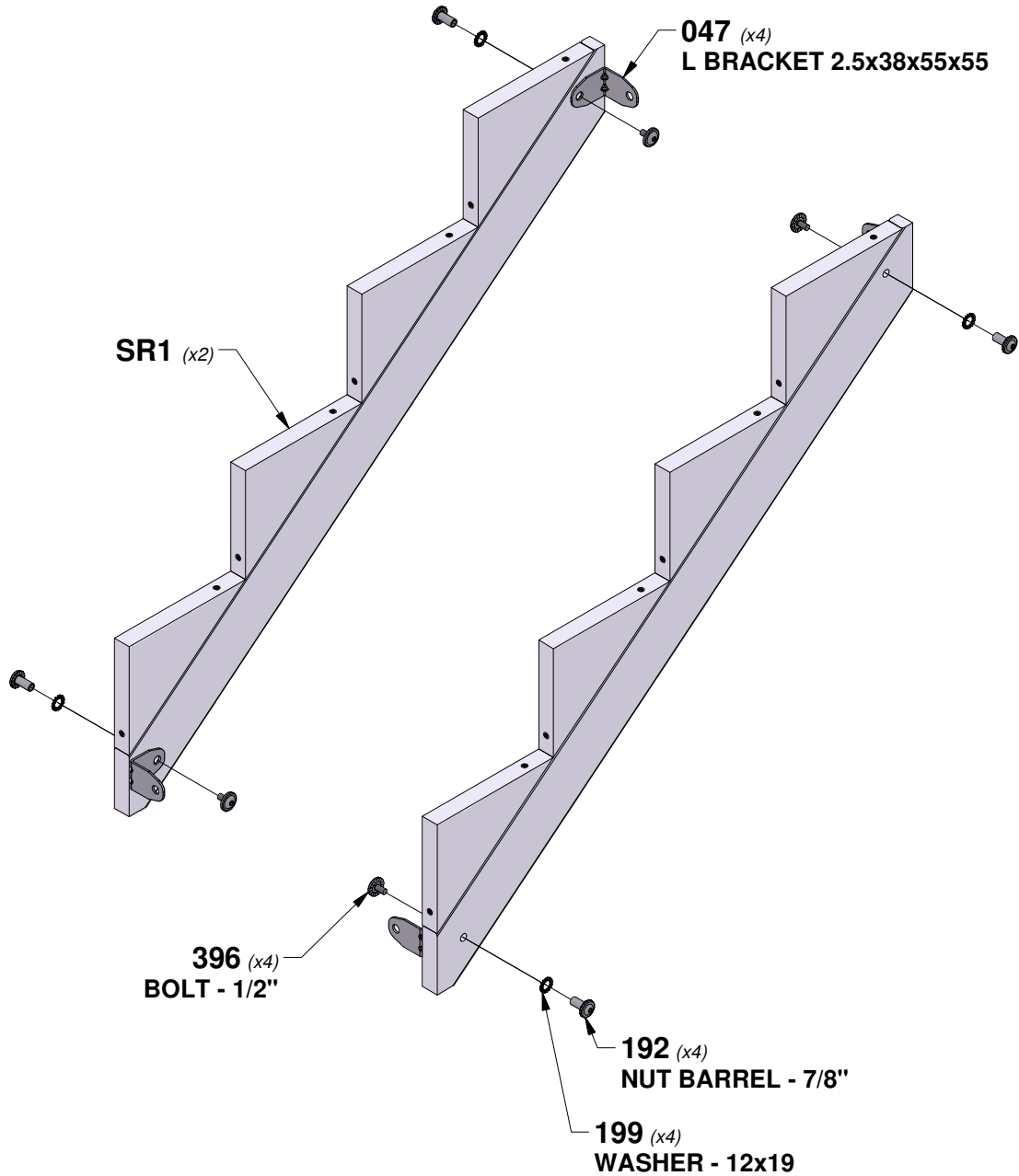

STEP 2 - STAIR ASSEMBLY

QTY	PART NUMBER	DESCRIPTION
10	H100087	SCREW PFH 8x1-1/4"



K19 | STAIR BOARD - W4L06619
(x1) | 5/8"x5 1/4"x20 5/8" (16x134x525)



M35 | STAIR BOARD - W4L06618
(x2) | 5/8"x3 3/8"x20 5/8" (16x86x525)



Y2 | STAIR BOARD - W4L06620
(x1) | 5/8"x2 5/8"x20 5/8" (16x67x525)

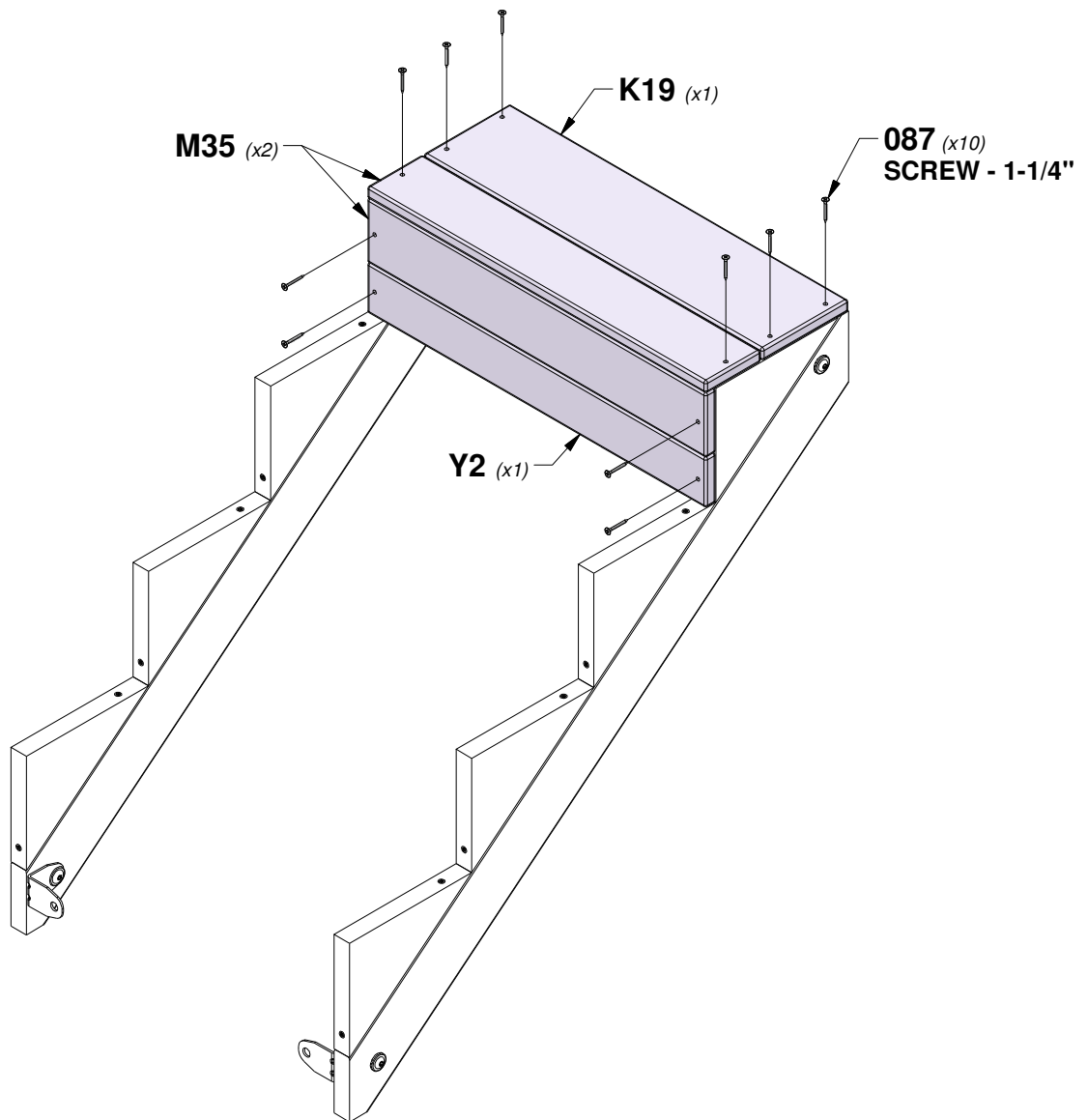

STEP 3 - STAIR ASSEMBLY

QTY	PART NUMBER	DESCRIPTION
10	H100087	SCREW PFH 8x1-1/4"



M35 | STAIR BOARD - W4L06618
(x2) | 5/8"x3 3/8"x20 5/8" (16x86x525)



Y1 | STAIR BOARD - W4L06621
(x1) | 5/8"x4"x20 5/8" (16x102x525)



Y2 | STAIR BOARD - W4L06620
(x1) | 5/8"x2 5/8"x20 5/8" (16x67x525)

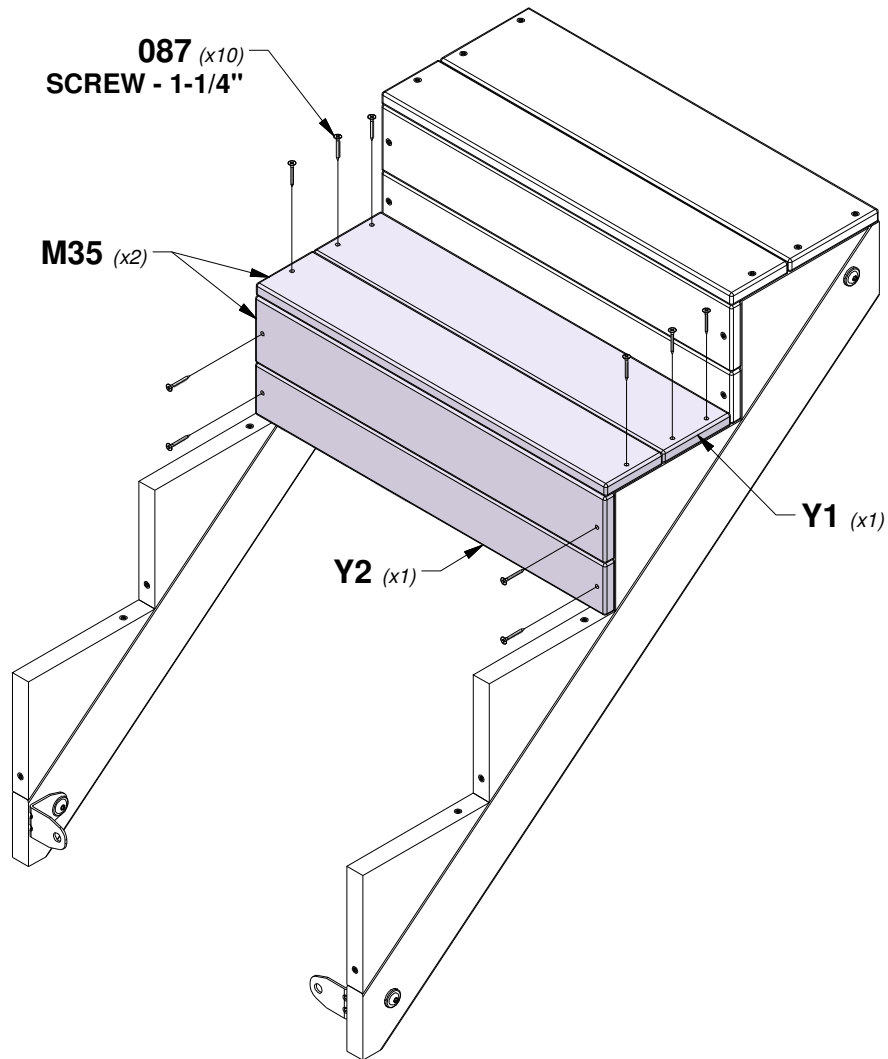

STEP 4 - STAIR ASSEMBLY

QTY	PART NUMBER	DESCRIPTION
10	H100087	SCREW PFH 8x1-1/4"



M35 | STAIR BOARD - W4L06618
(x2) | 5/8"x3 3/8"x20 5/8" (16x86x525)



Y1 | STAIR BOARD - W4L06621
(x1) | 5/8"x4"x20 5/8" (16x102x525)



Y2 | STAIR BOARD - W4L06620
(x1) | 5/8"x2 5/8"x20 5/8" (16x67x525)

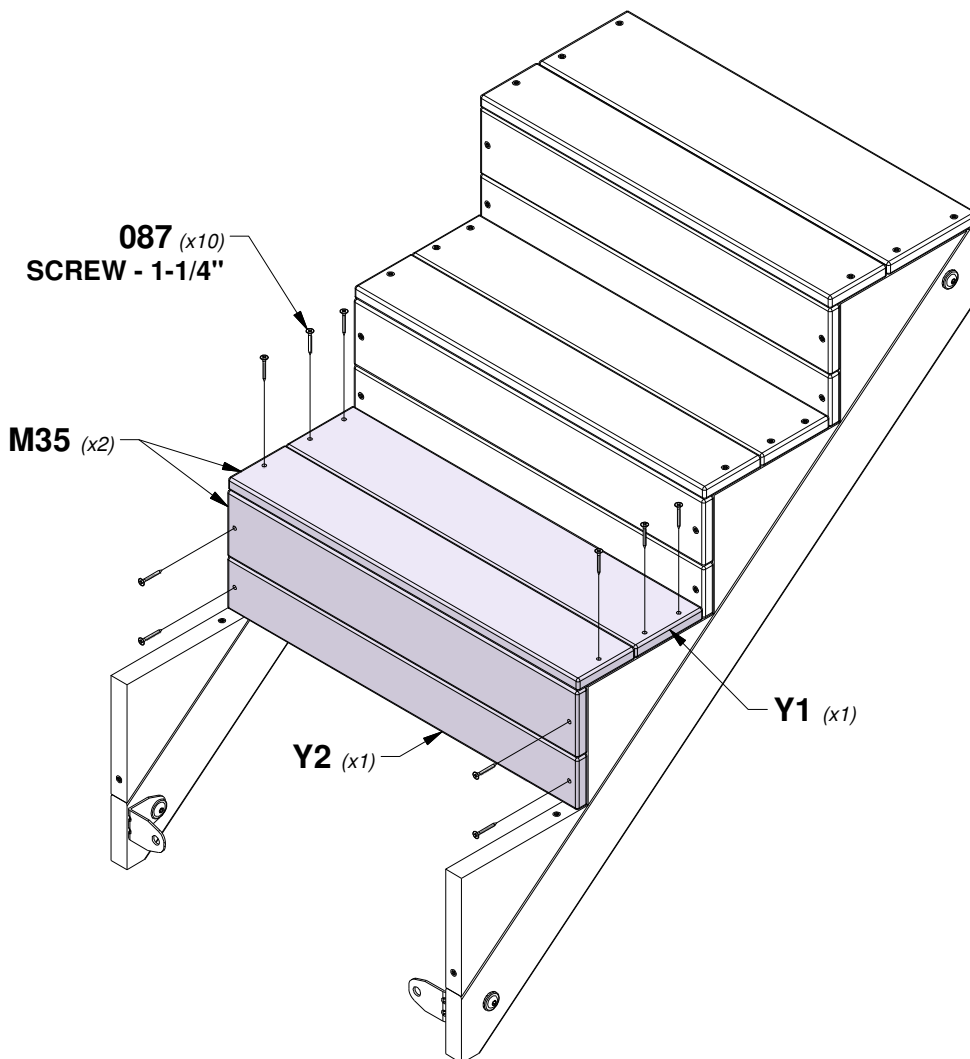

STEP 5 - STAIR ASSEMBLY

QTY	PART NUMBER	DESCRIPTION
10	H100087	SCREW PFH 8x1-1/4"



K19 | STAIR BOARD - W4L06619
(x1) | 5/8"x5 1/4"x20 5/8" (16x134x525)



M35 | STAIR BOARD - W4L06618
(x2) | 5/8"x3 3/8"x20 5/8" (16x86x525)



Y1 | STAIR BOARD - W4L06621
(x1) | 5/8"x4"x20 5/8" (16x102x525)

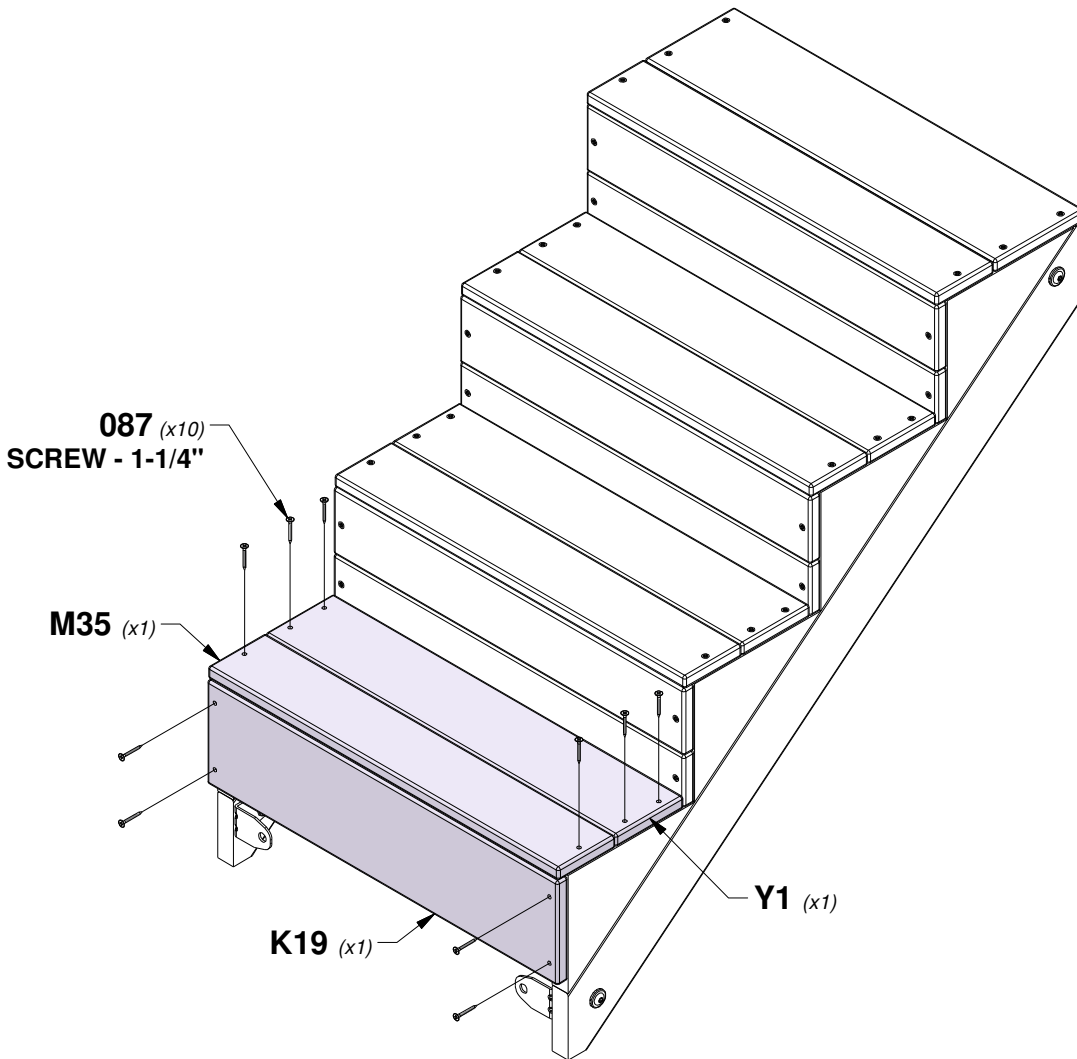

STEP 1 - DECK ASSEMBLY

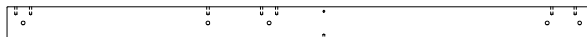

E2 | RIGHT FRONT UPRIGHT - W4L16906
(x1) | 1 3/8"x3 3/8"x60 5/8" (36x86x1540)

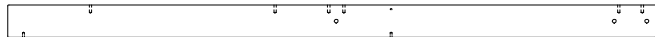

E3 | RIGHT REAR UPRIGHT - W4L16907
(x1) | 1 3/8"x3 3/8"x67 1/2" (36x86x1715)

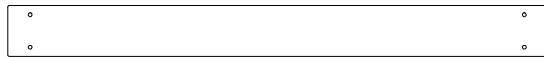

K2 | GROUND BOARD - W4L06390
(x1) | 5/8"x5 1/4"x56 1/8" (16x134x1426)

QTY	PART NUMBER	DESCRIPTION
6	H100198	WASHER LOCK EXT 8x19 BLK
2	H100205	BOLT WH 5/16x2-1/4 BLK
6	H100379	T-NUT 5/16 BLK
4	H100457	BOLT WH 5/16x2 BLK



H4 | FLOOR RAIL - W4L06396
(x1) | 1"x3 3/8"x54 7/8" (24x86x1394)

TIP:
INSTALL T-NUTS IN WOOD FIRST

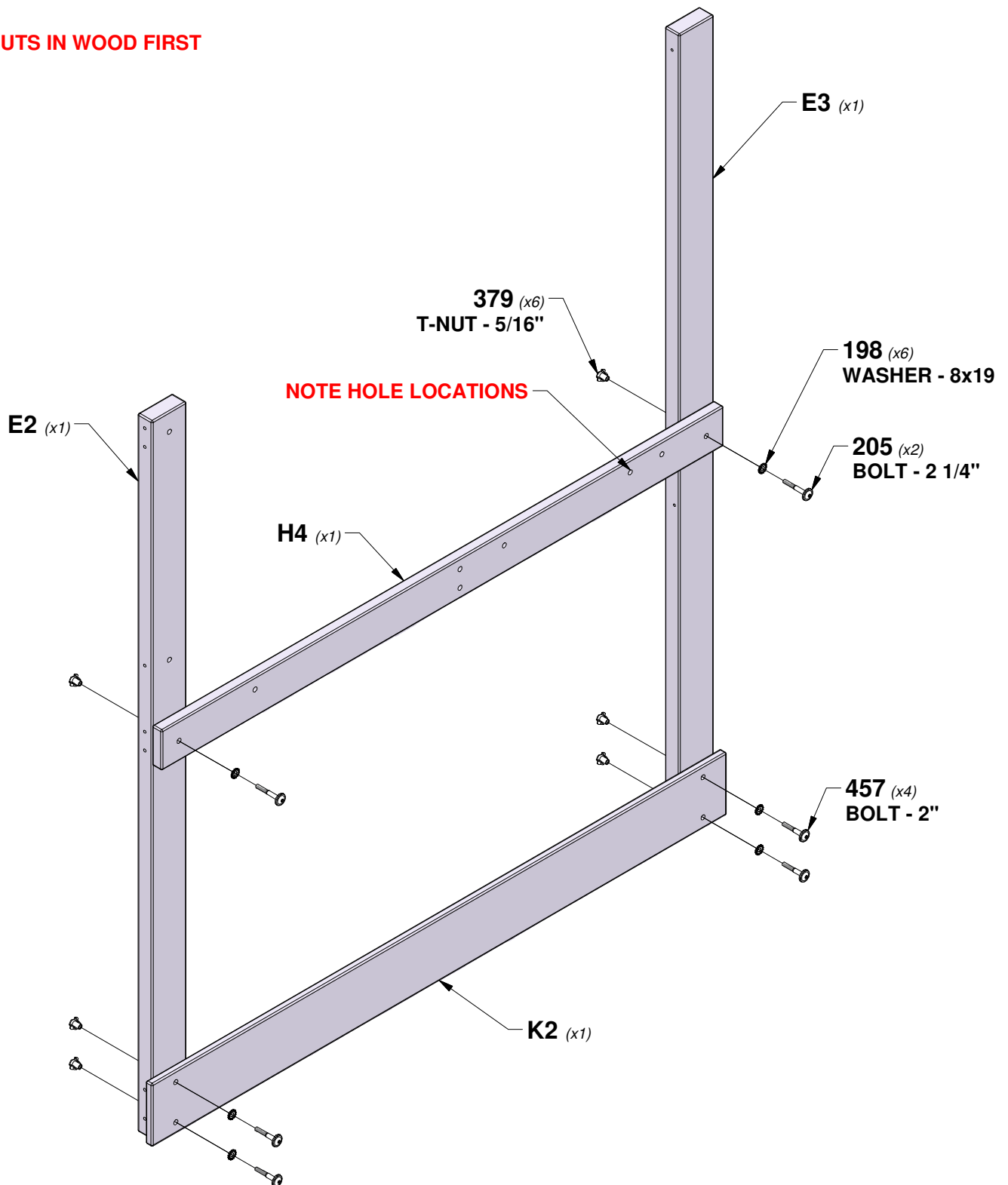

STEP 2 - DECK ASSEMBLY

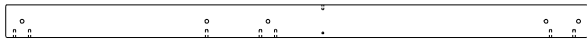

E1 | LEFT FRONT UPRIGHT - W4L16905
(x1) | 1 3/8"x3 3/8"x60 5/8" (36x86x1540)



H2 | FLOOR RAIL - W4L06392
(x1) | 1"x3 3/8"x54 7/8" (24x86x1394)



K2 | GROUND BOARD - W4L06390
(x1) | 5/8"x5 1/4"x56 1/8" (16x134x1426)



E4 | LEFT REAR UPRIGHT - W4L16908
(x1) | 1 3/8"x3 3/8"x35" (36x86x889)

QTY	PART NUMBER	DESCRIPTION
6	H100198	WASHER LOCK EXT 8x19 BLK
2	H100205	BOLT WH 5/16x2-1/4 BLK
6	H100379	T-NUT 5/16 BLK
4	H100457	BOLT WH 5/16x2 BLK

TIP:
INSTALL T-NUTS IN WOOD FIRST

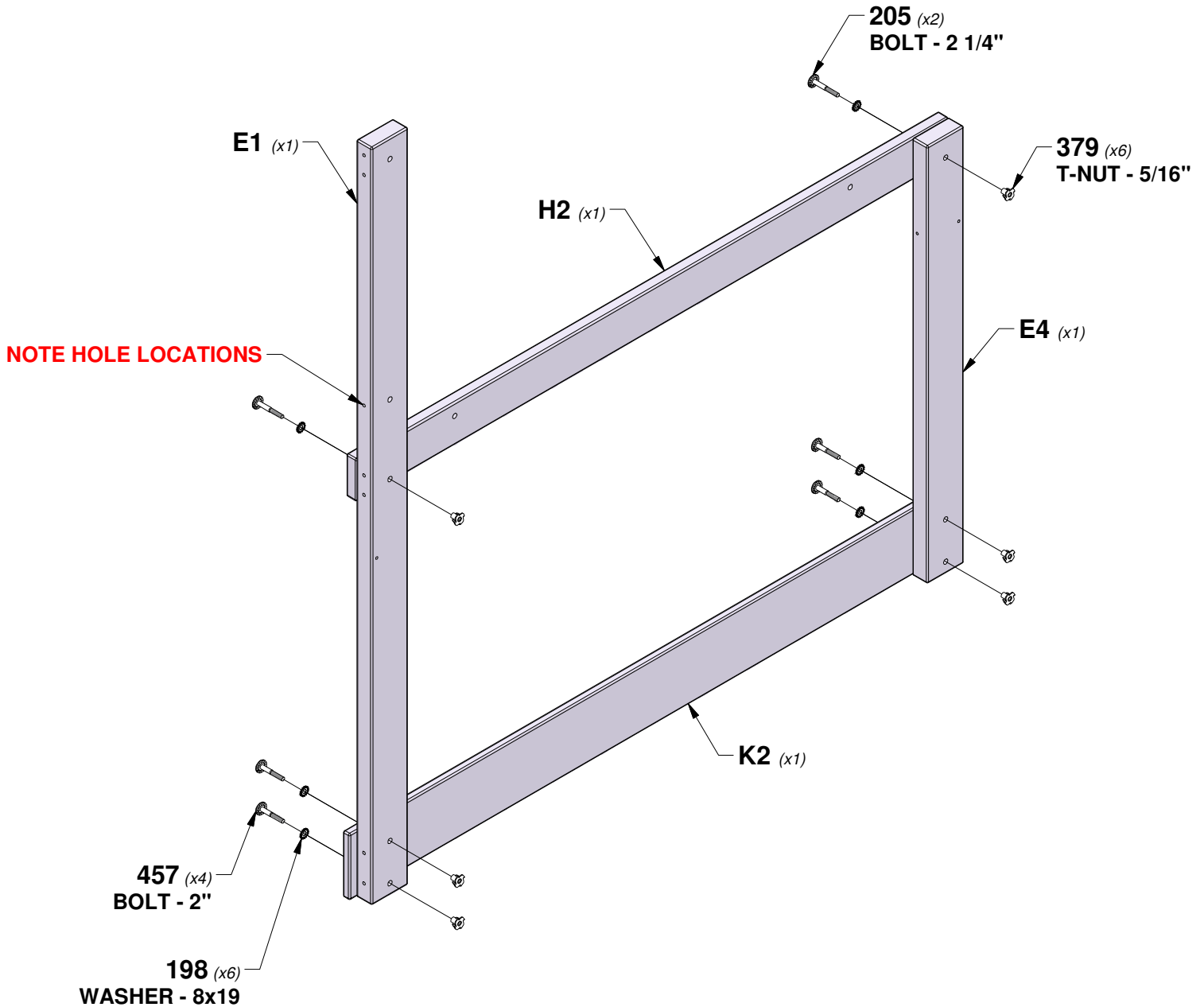

STEP 3 - DECK ASSEMBLY

QTY	PART NUMBER	DESCRIPTION
20	H100198	WASHER LOCK EXT 8x19 BLK
16	H100458	LAG SCREW WH 5/16x2 BLK
4	H100471	LAG SCREW WH 5/16x1-1/2 BLK



H1 | FLOOR RAIL - W4L06391
(x1) | 1"x3 3/8"x56 3/4" (24x86x1442)



H3 | FLOOR RAIL - W4L06395
(x1) | 1"x3 3/8"x56 3/4" (24x86x1442)

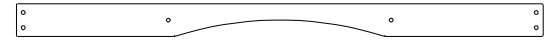

M3 | WALL RAIL - W4L06394
(x1) | 5/8"x3 3/8"x54 7/8" (16x86x1394)



K1 | GROUND BOARD - W4L06389
(x2) | 5/8"x5 1/4"x54 7/8" (16x134x1394)

TIP:
INSTALL T-NUTS IN WOOD FIRST

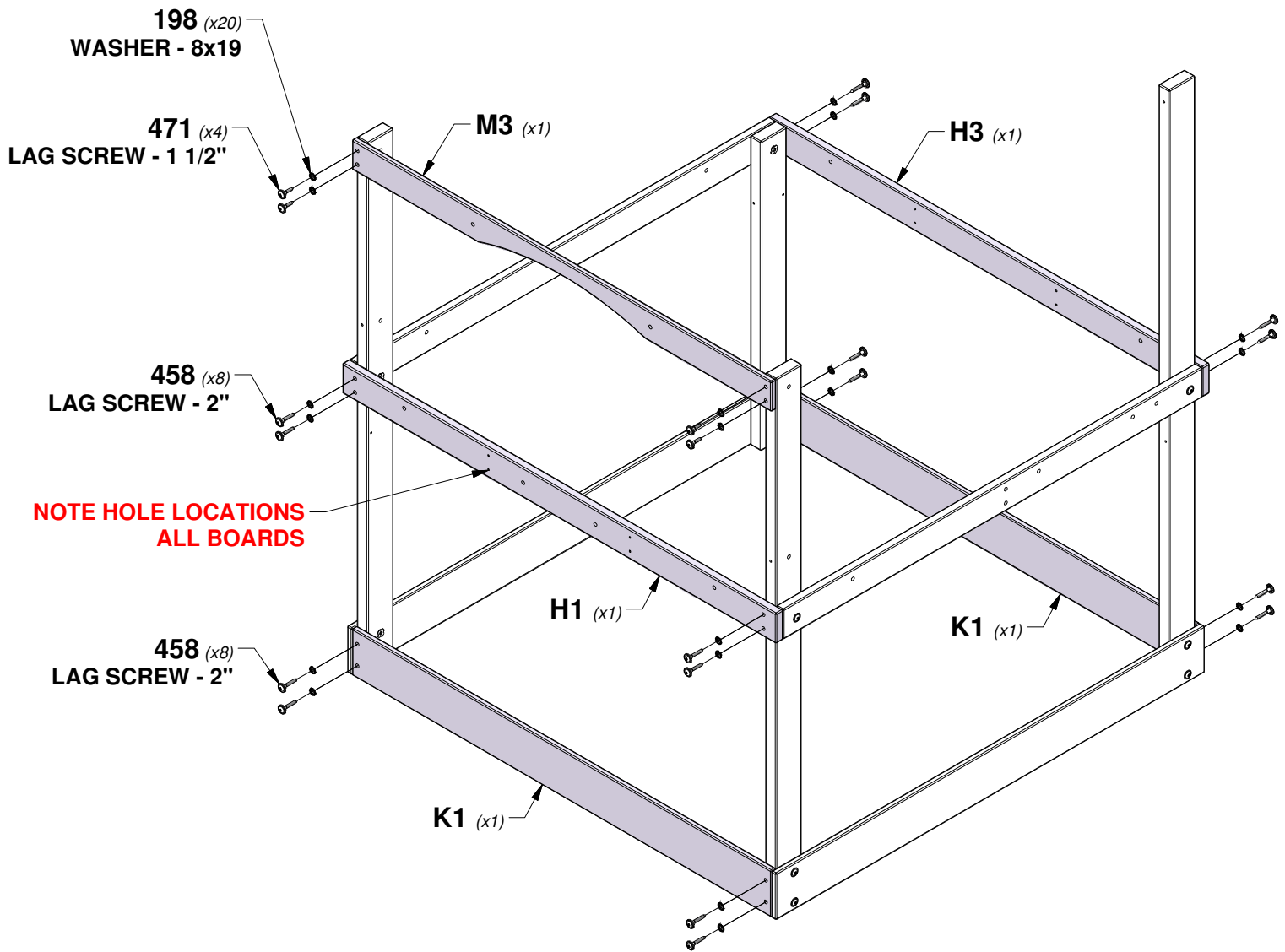

STEP 4 - DECK ASSEMBLY

QTY	PART NUMBER	DESCRIPTION
8	H100198	WASHER LOCK EXT 8x19 BLK
8	H100205	BOLT WH 5/16x2-1/4 BLK
8	H100379	T-NUT 5/16 BLK
8	H100403	LAG SCREW WH 1/4x1-1/2 BLK
8	H100405	WASHER LOCK EXT 6x15 BLK



E6 | DECK BRACE - W4L16834
 (x8) | 1 3/8"x3 3/8"x11 15/16" (36x86x303)

TIP:
 INSTALL T-NUTS IN WOOD FIRST

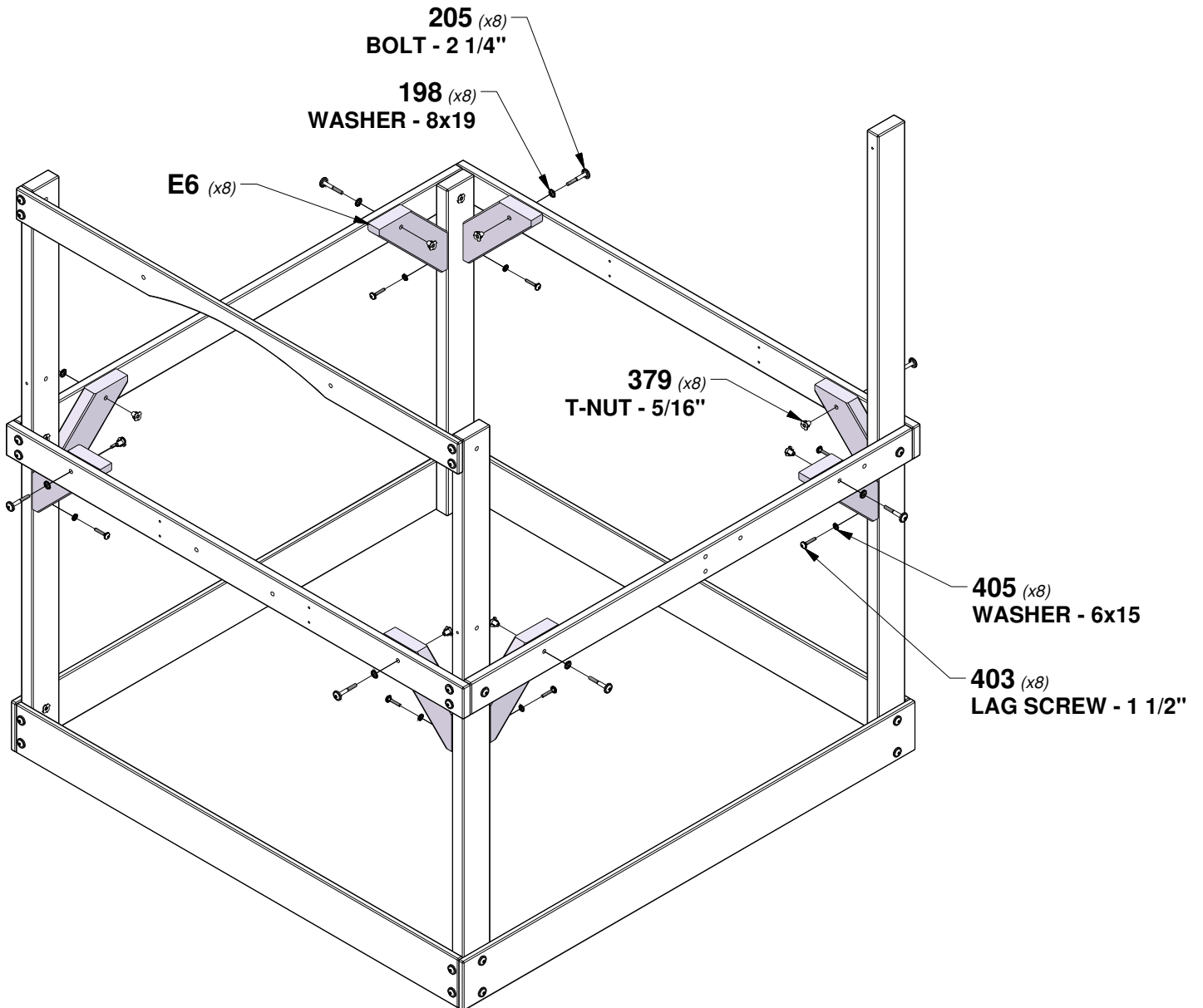

STEP 5 - DECK ASSEMBLY

QTY	PART NUMBER	DESCRIPTION
8	H100090	SCREW PFH 8x2 1/2



H5 | FLOOR SUPPORT - W4L06399
(x2) 1"x3 3/8"x54 7/8" (24x86x1394)

NOTE:
FLUSH TOPS OF BOARDS ALL PLACES

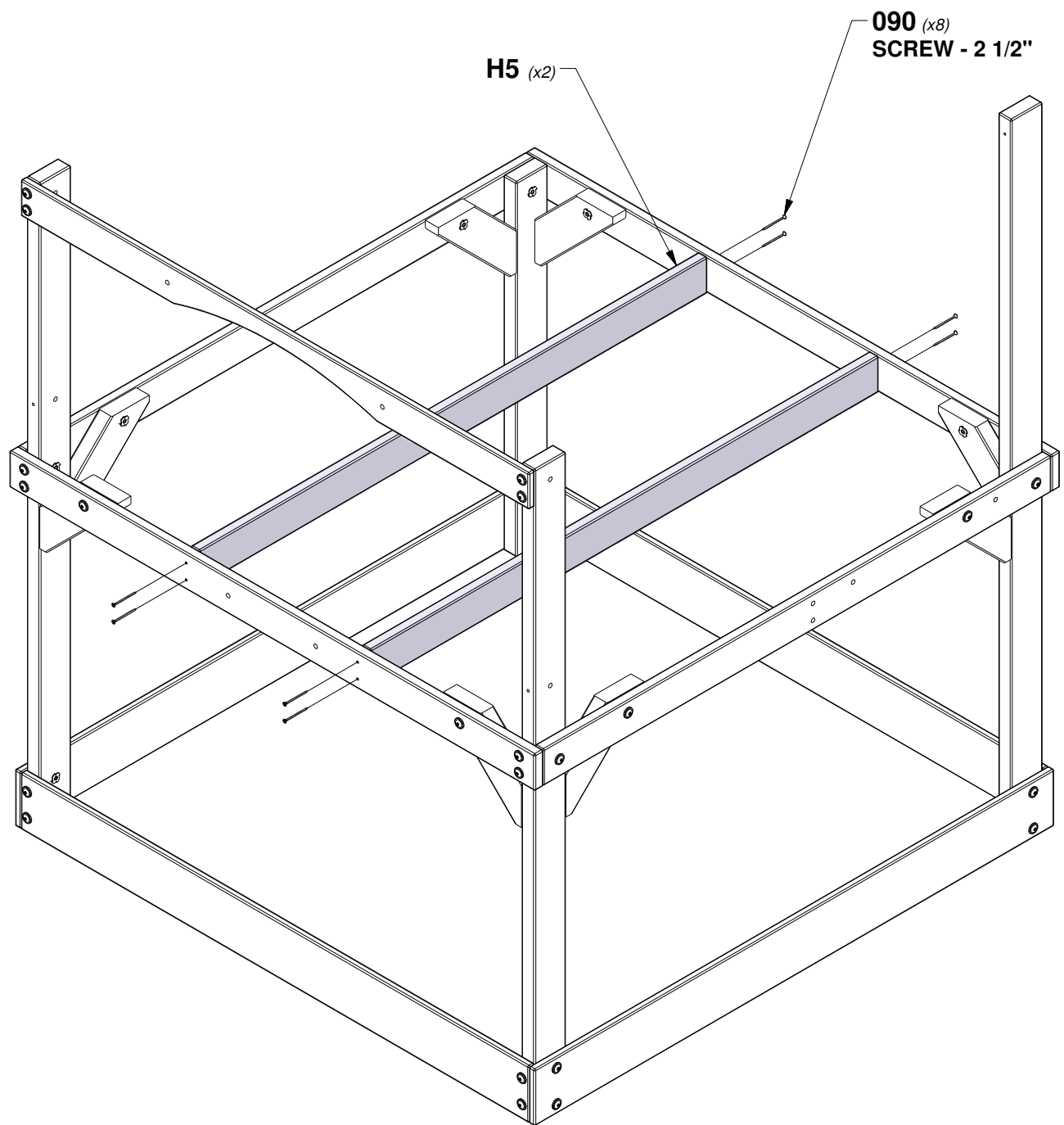

STEP 6 - DECK ASSEMBLY

QTY	PART NUMBER	DESCRIPTION
2	H100198	WASHER LOCK EXT 8x19 BLK
2	H100379	T-NUT 5/16 BLK
2	H100484	BOLT WH 5/16x3 1/4 BLK



E5 | RAIL UPRIGHT - W4L16832
(x1) | 1 3/8"x3 3/8"x35 7/8" (36x86x912)



H15 | FLOOR SUPPORT BLOCK - W4L16831
(x1) | 1"x3 3/8"x3 3/8" (24x86x86)

TIP:
INSTALL T-NUTS IN WOOD FIRST

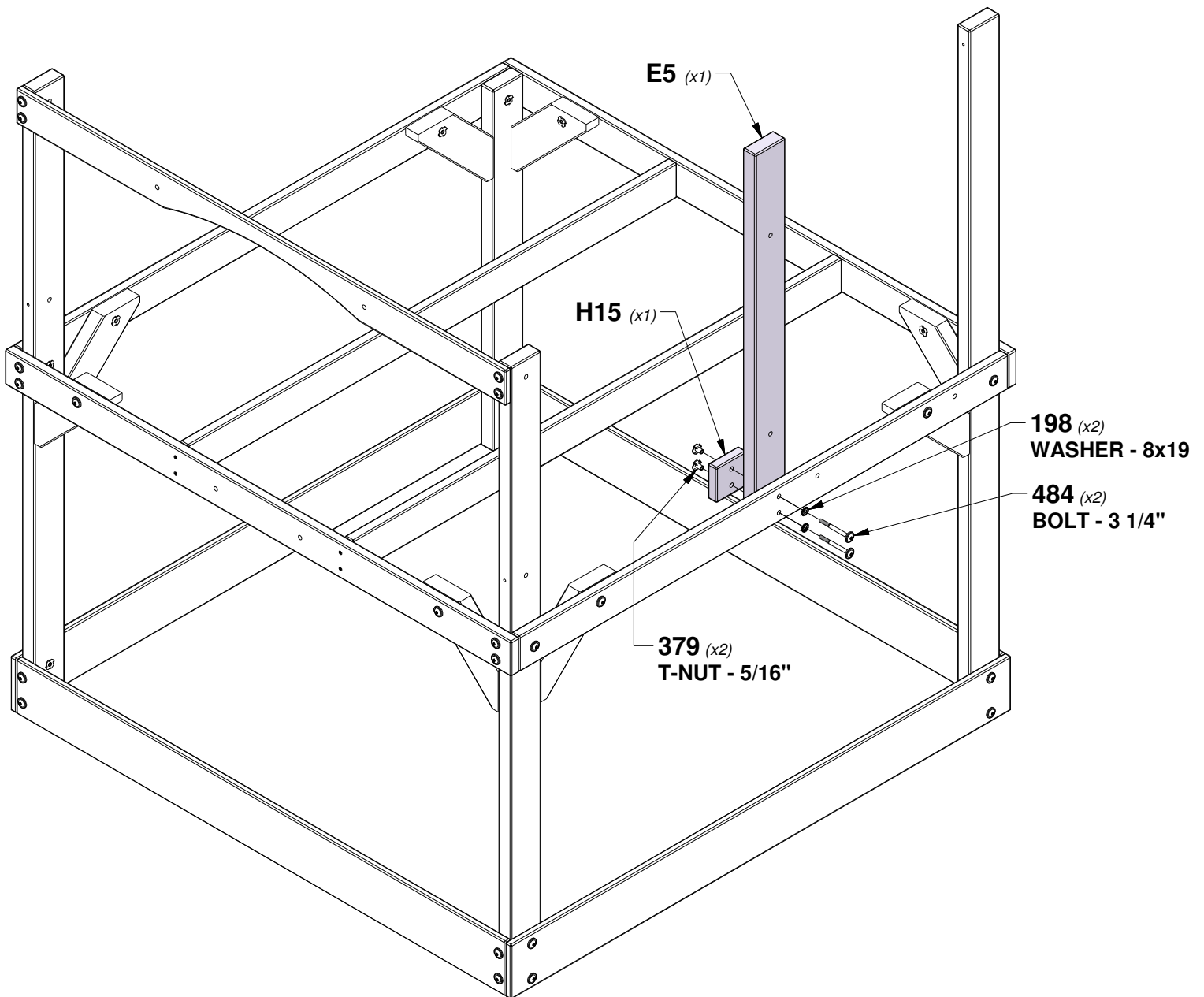

STEP 7 - DECK ASSEMBLY

QTY	PART NUMBER	DESCRIPTION
92	H100086	SCREW PFH 8x1-1/2"



M4 | FLOOR BOARD - W4L16829
(x13) | 5/8"x3 3/8"x56 3/4" (16x86x1442)



M5 | FLOOR BOARD - W4L16830
(x1) | 5/8"x3 3/8"x54 3/8" (16x86x1382)



L1 | FLOOR BOARD - W4L06400
(x1) | 5/8"x4 3/8"x52" (16x112x1321)



L2 | FLOOR BOARD - W4L06404
(x1) | 5/8"x4 3/8"x54 3/8" (16x112x1382)

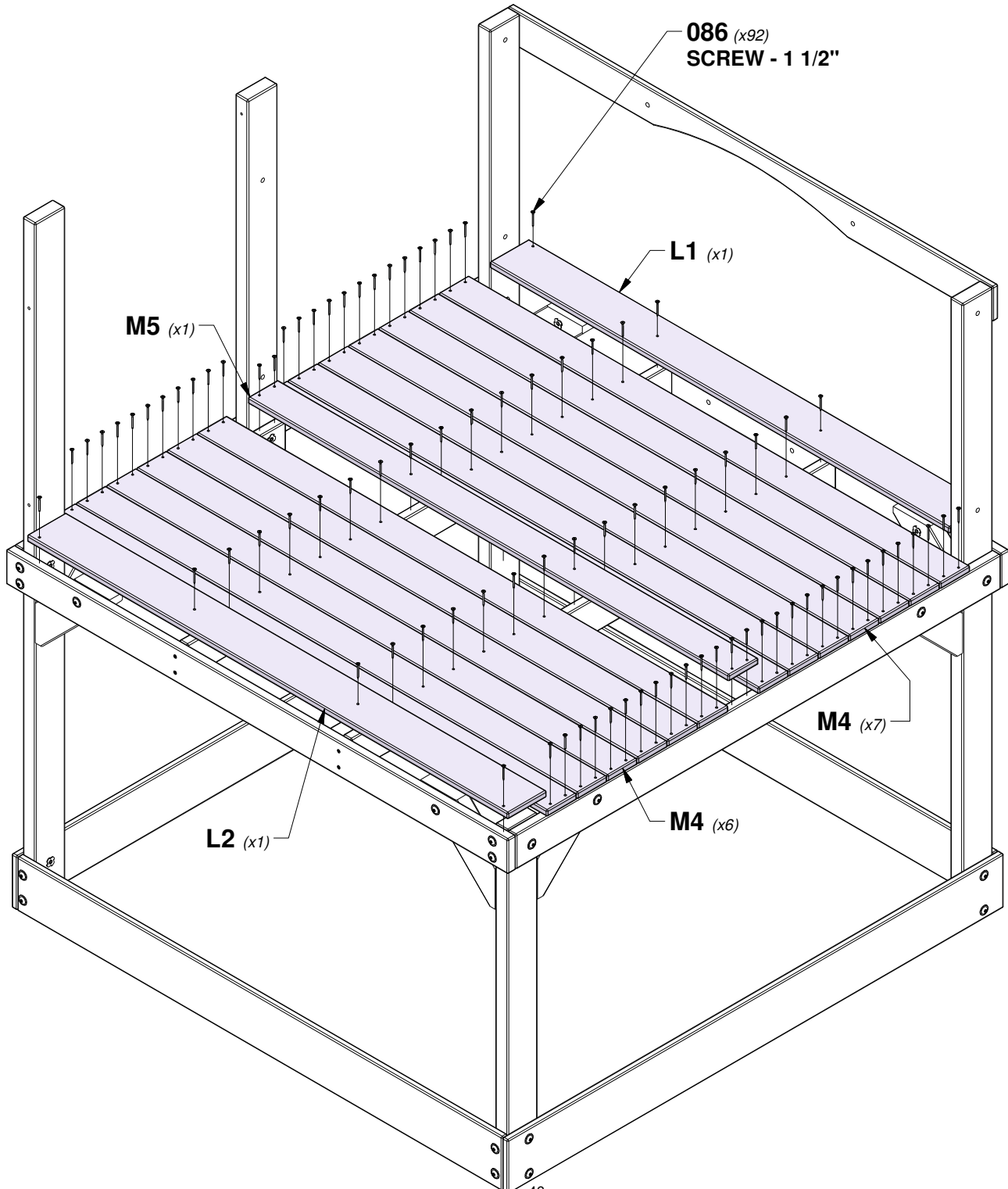

STEP 8 - DECK ASSEMBLY

QTY	PART NUMBER	DESCRIPTION
2	H100198	WASHER LOCK EXT 8x19 BLK
2	H100458	LAG SCREW WH 5/16x2 BLK



M2 | WALL RAIL - W4L06393
 (x2) | 5/8"x3 3/8"x17 1/2" (16x86x445)

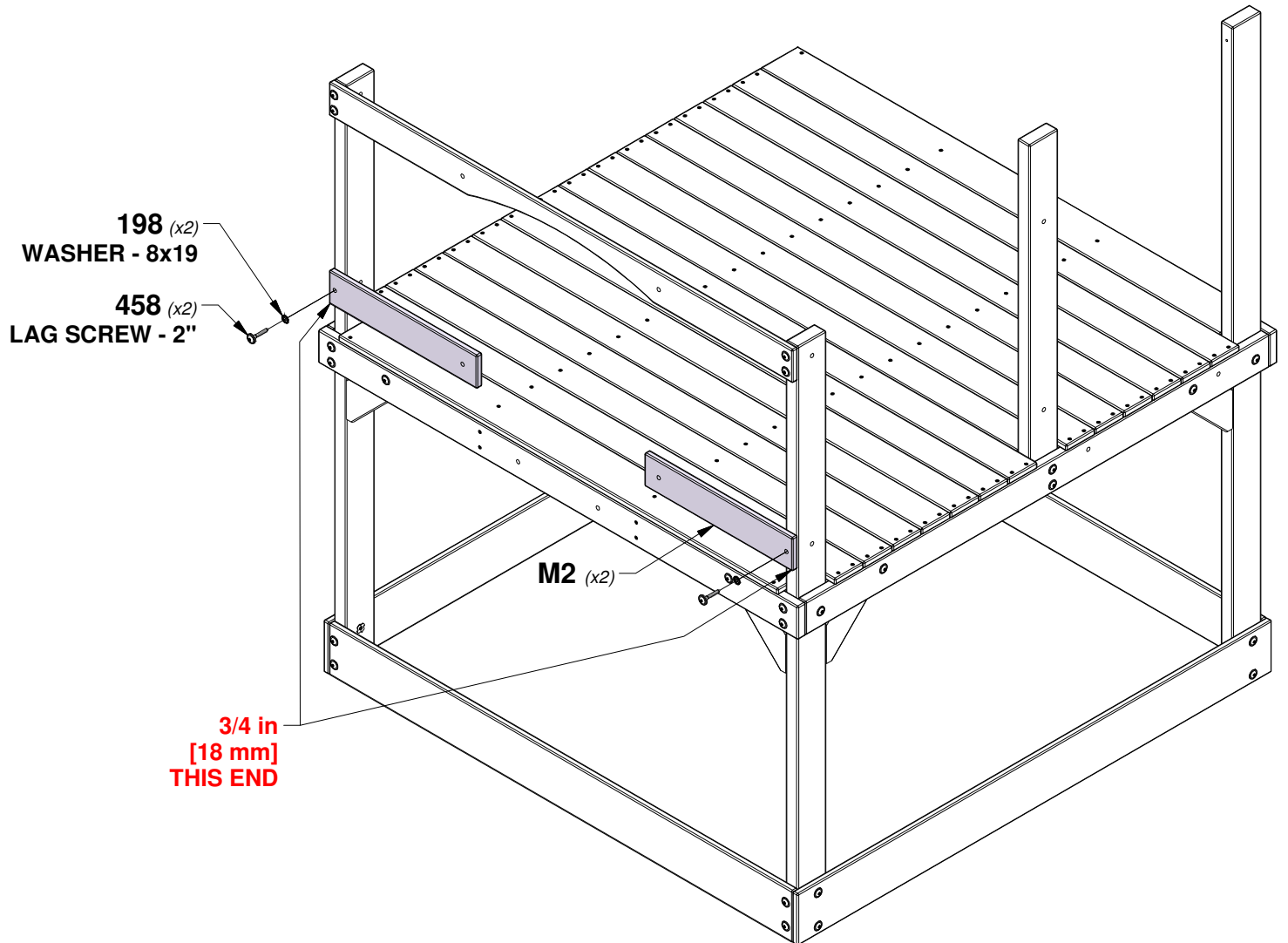

STEP 9 - DECK ASSEMBLY

QTY	PART NUMBER	DESCRIPTION
4	H100086	SCREW PFH 8x1-1/2"
4	H100198	WASHER LOCK EXT 8x19 BLK
4	H100379	T-NUT 5/16 BLK
4	H100457	BOLT WH 5/16x2 BLK

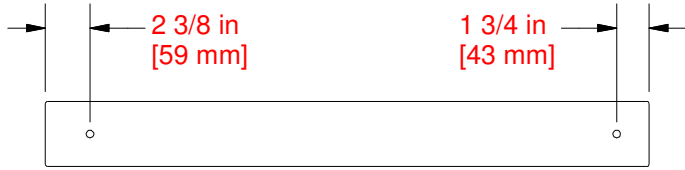

M7 | WALL RAIL - W4L06406
(x2) | 5/8"x3 3/8"x31 1/2" (16x86x799)



M36 | FILLER BOARD - W4L06800
(x1) | 5/8"x3 3/8"x3" (16x86x76)

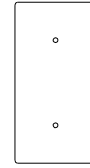

M37 | FILLER BOARD - W4L06801
(x1) | 5/8"x3 3/8"x6 3/4" (16x86x170)

TIP:
INSTALL T-NUTS IN WOOD FIRST

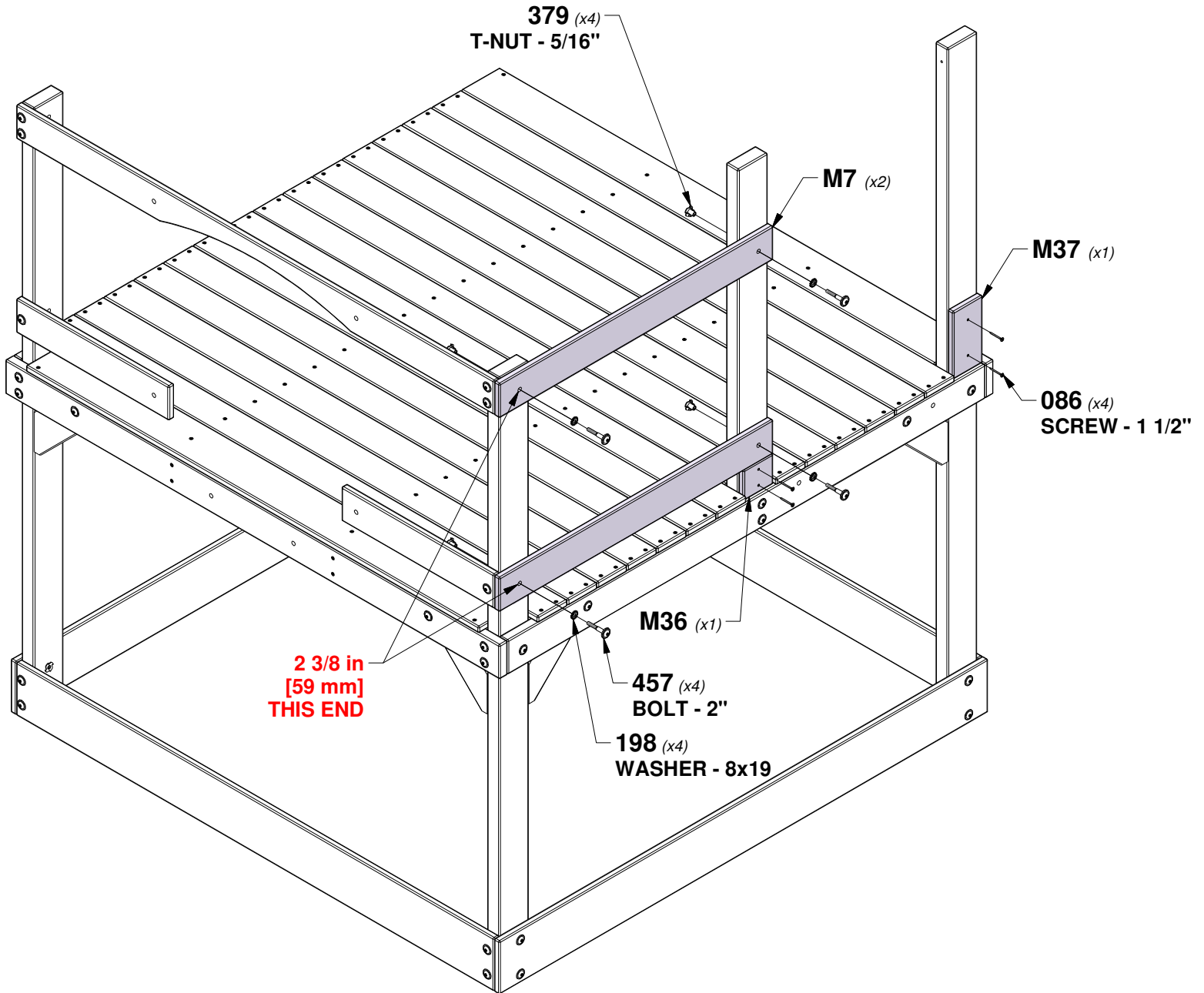

STEP 10 - DECK ASSEMBLY

QTY	PART NUMBER	DESCRIPTION
2	H100198	WASHER LOCK EXT 8x19 BLK
2	H100379	T-NUT 5/16 BLK
2	H100457	BOLT WH 5/16x2 BLK



M8 | WALL RAIL - W4L06409
 (x2) | 5/8"x3 3/8"x17 1/4" (16x86x439)

TIP:
 INSTALL T-NUTS IN WOOD FIRST

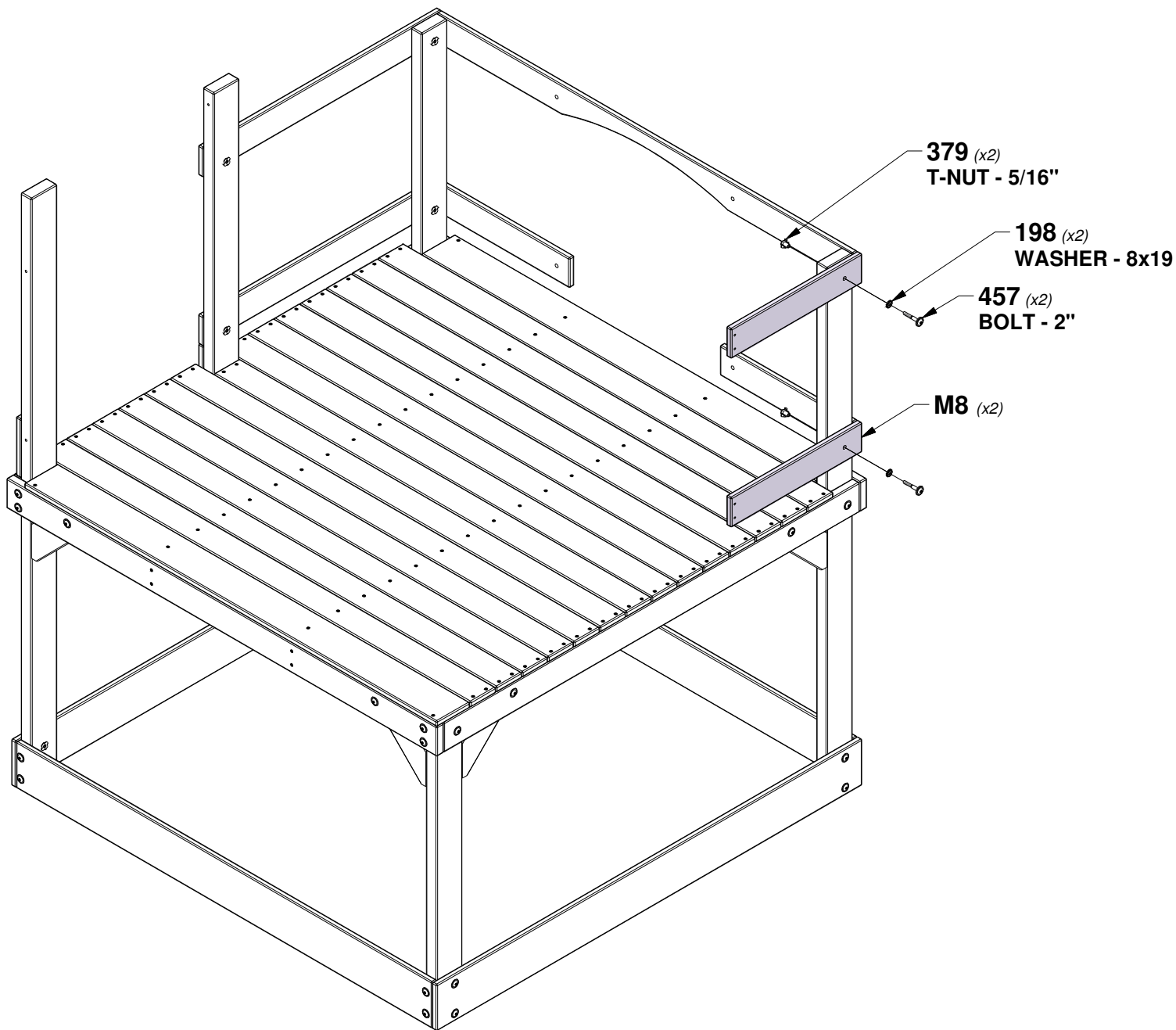

STEP 11 - DECK ASSEMBLY

QTY	PART NUMBER	DESCRIPTION
2	H100198	WASHER LOCK EXT 8x19 BLK
2	H100471	LAG SCREW WH 5/16x1-1/2 BLK



M9 | WALL RAIL - W4L06410
(x2) | 5/8"x3 3/8"x16 5/8" (16x86x423)

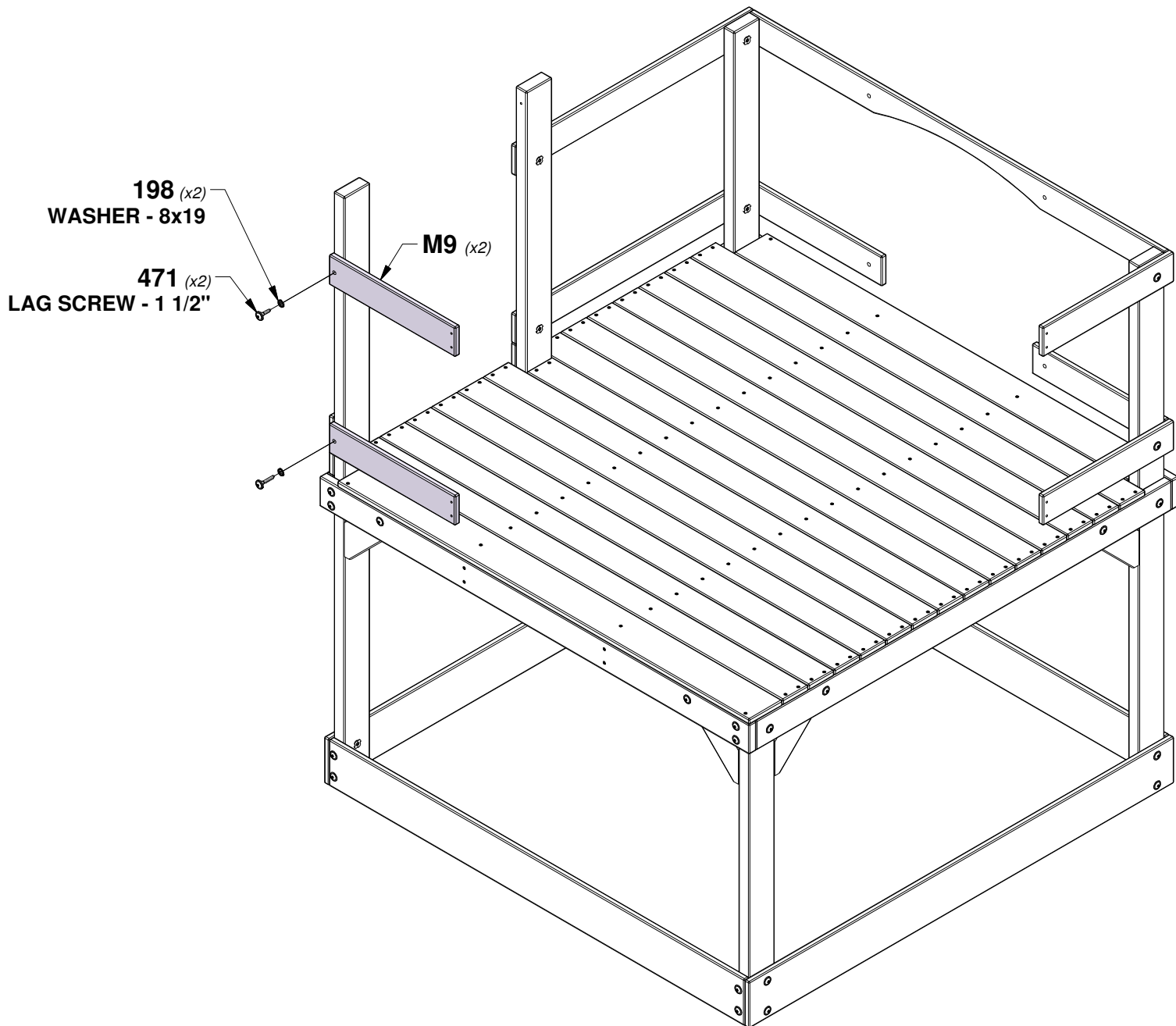

STEP 12 - DECK ASSEMBLY

QTY	PART NUMBER	DESCRIPTION
4	H100198	WASHER LOCK EXT 8x19 BLK
4	H100379	T-NUT 5/16 BLK
4	H100459	BOLT WH 5/16x1 1/4 BLK



TOP

M6 | WALL BOARD - W4L16833
 (x2) | 5/8"x3 3/8"x25" (16x86x635)

TIP:
 INSTALL T-NUTS IN WOOD FIRST

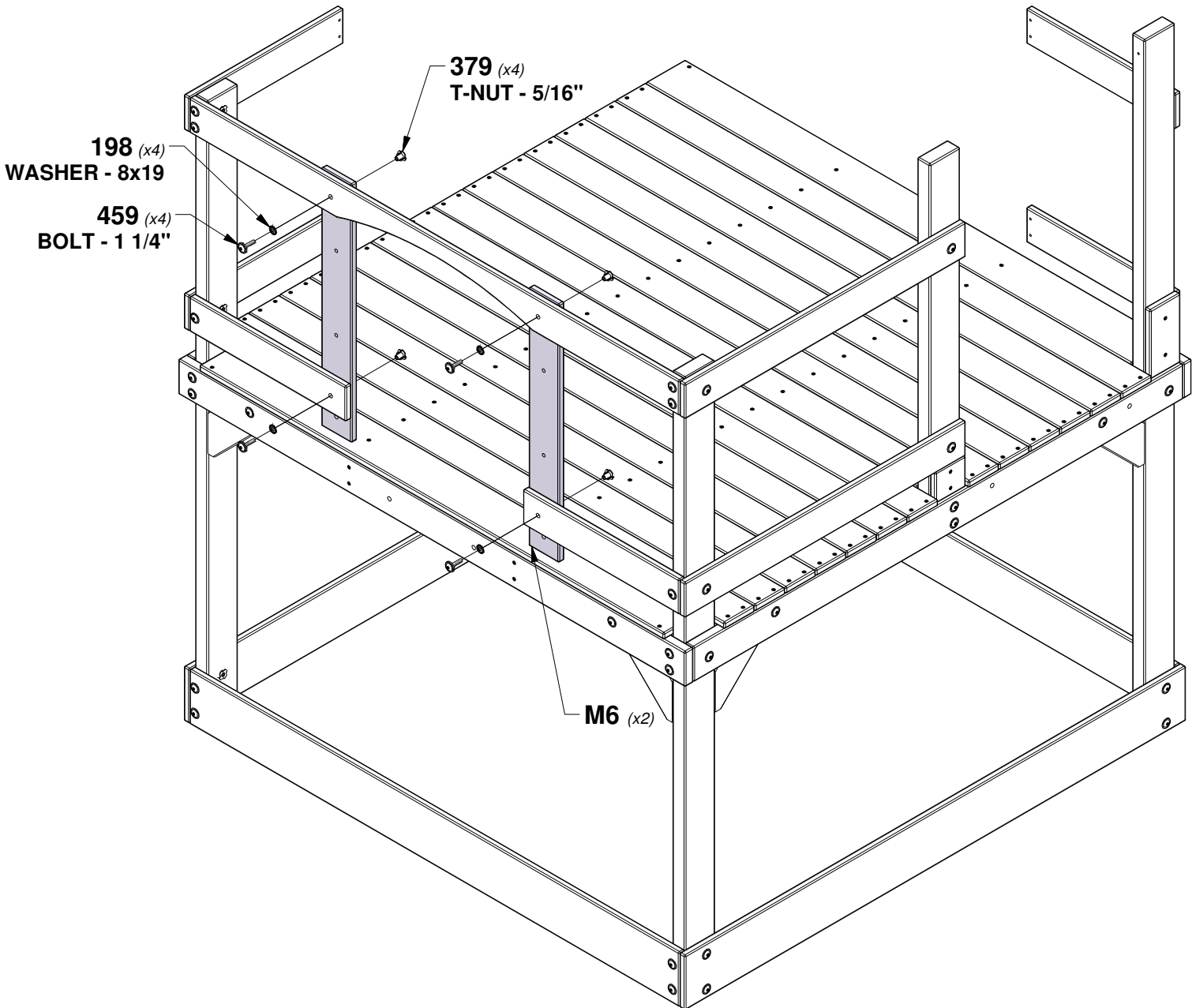

STEP 13 - DECK ASSEMBLY

QTY	PART NUMBER	DESCRIPTION
8	H100088	SCREW PFH 8x1-1/8"



S1 | RAIL BOARD - W4L06408
(x2) | 1"x1"x25 1/4" (24x24x640)

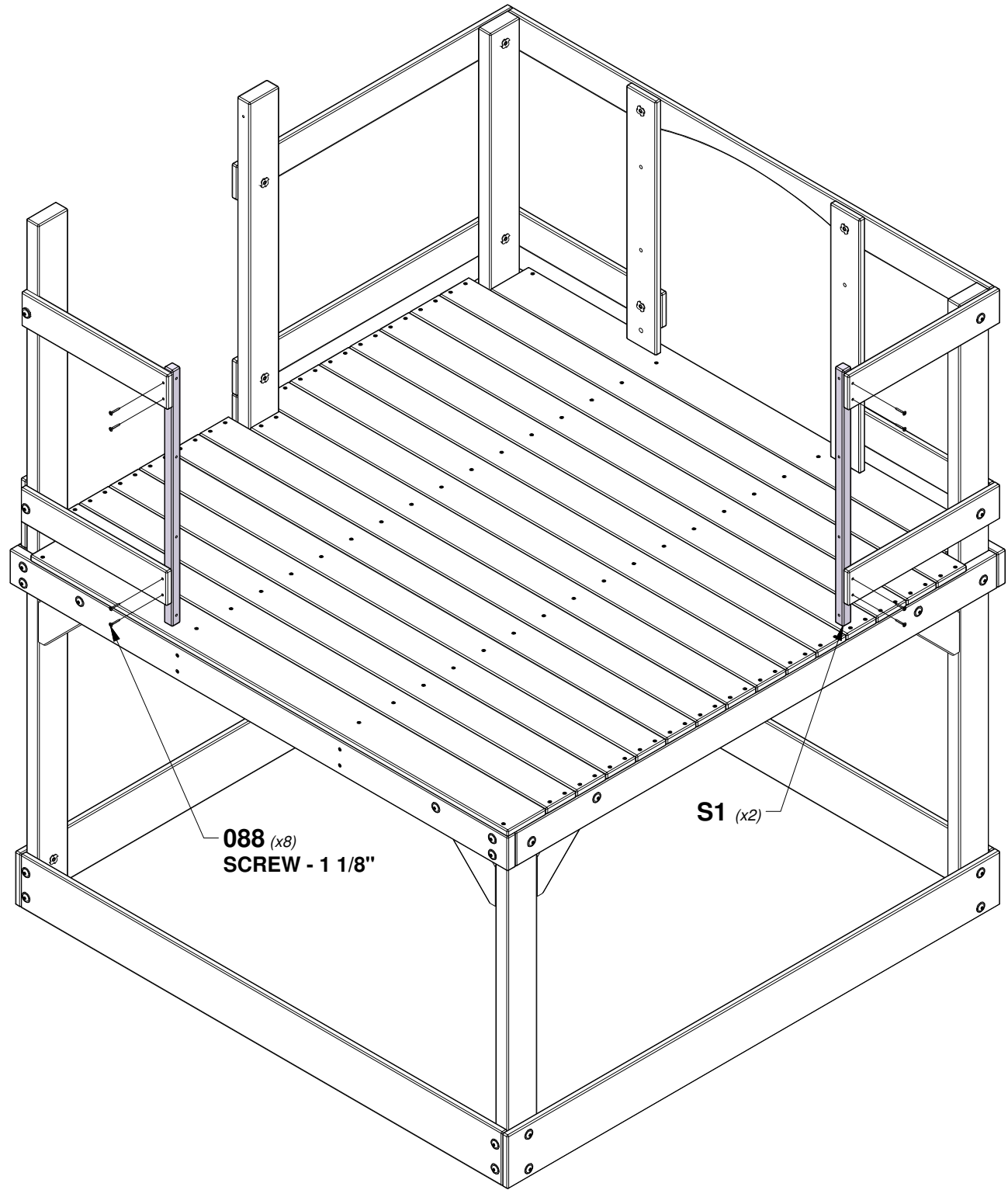

STEP 14 - DECK ASSEMBLY

QTY	PART NUMBER	DESCRIPTION
6	H100088	SCREW PFH 8x1-1/8"



O2 PICKET - W4L06407
 (x3) 5/8"x1 3/8"x18 3/4" (16x34x476)

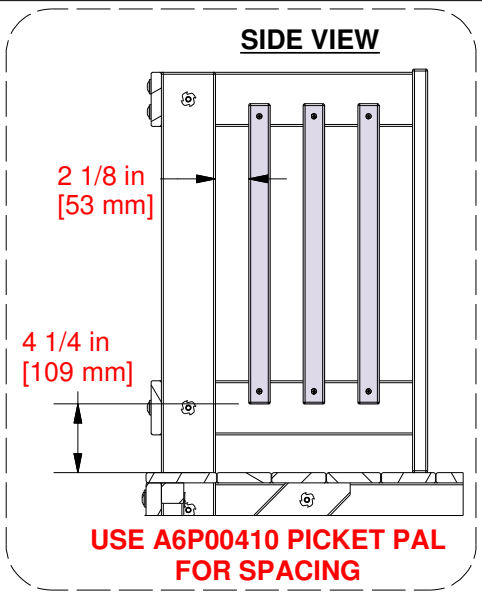
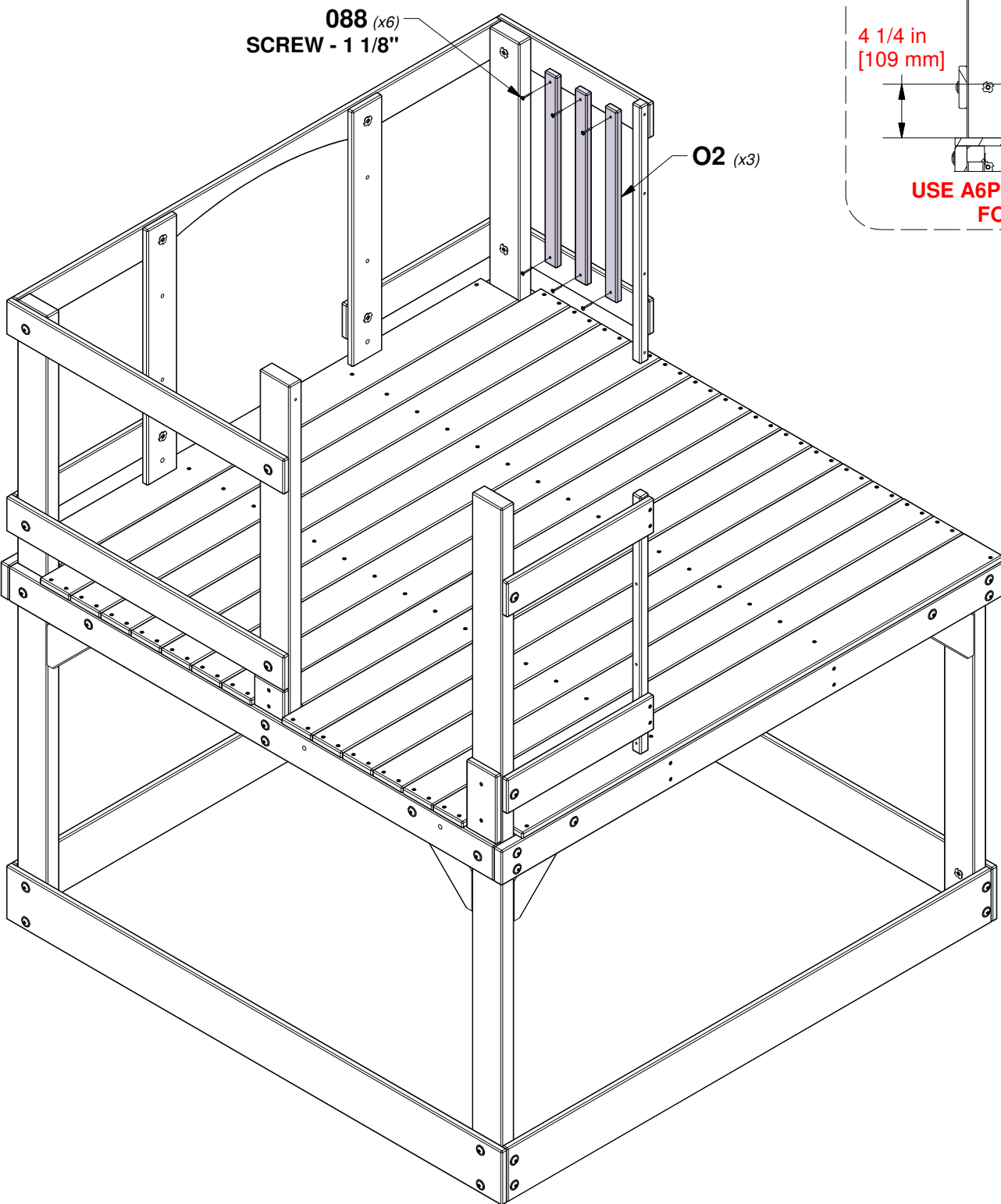

STEP 15 - DECK ASSEMBLY

QTY	PART NUMBER	DESCRIPTION
6	H100088	SCREW PFH 8x1-1/8"



O2 PICKET - W4L06407
(x3) 5/8"x1 3/8"x18 3/4" (16x34x476)

O2 (x3)
O88 (x6)
SCREW - 1 1/8"

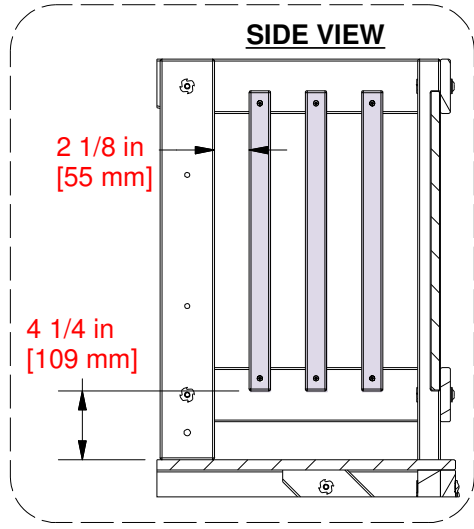
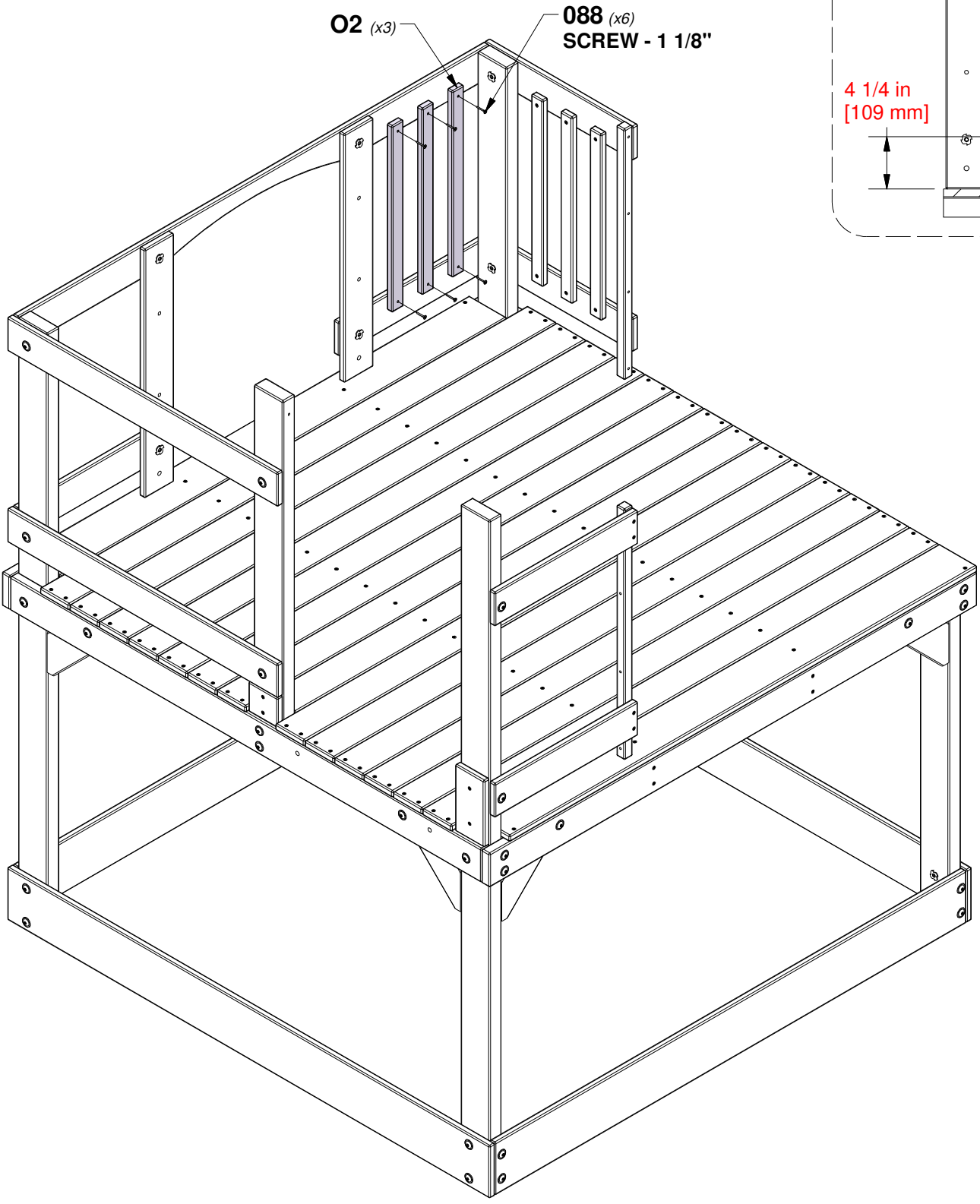

STEP 16 - DECK ASSEMBLY

QTY	PART NUMBER	DESCRIPTION
6	H100088	SCREW PFH 8x1-1/8"



O2 PICKET - W4L06407
 (x3) | 5/8"x1 3/8"x18 3/4" (16x34x476)

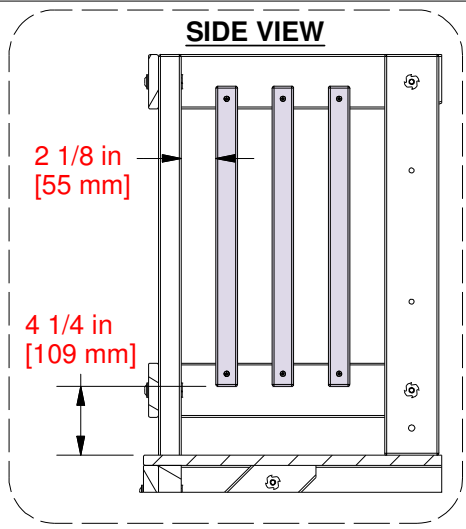
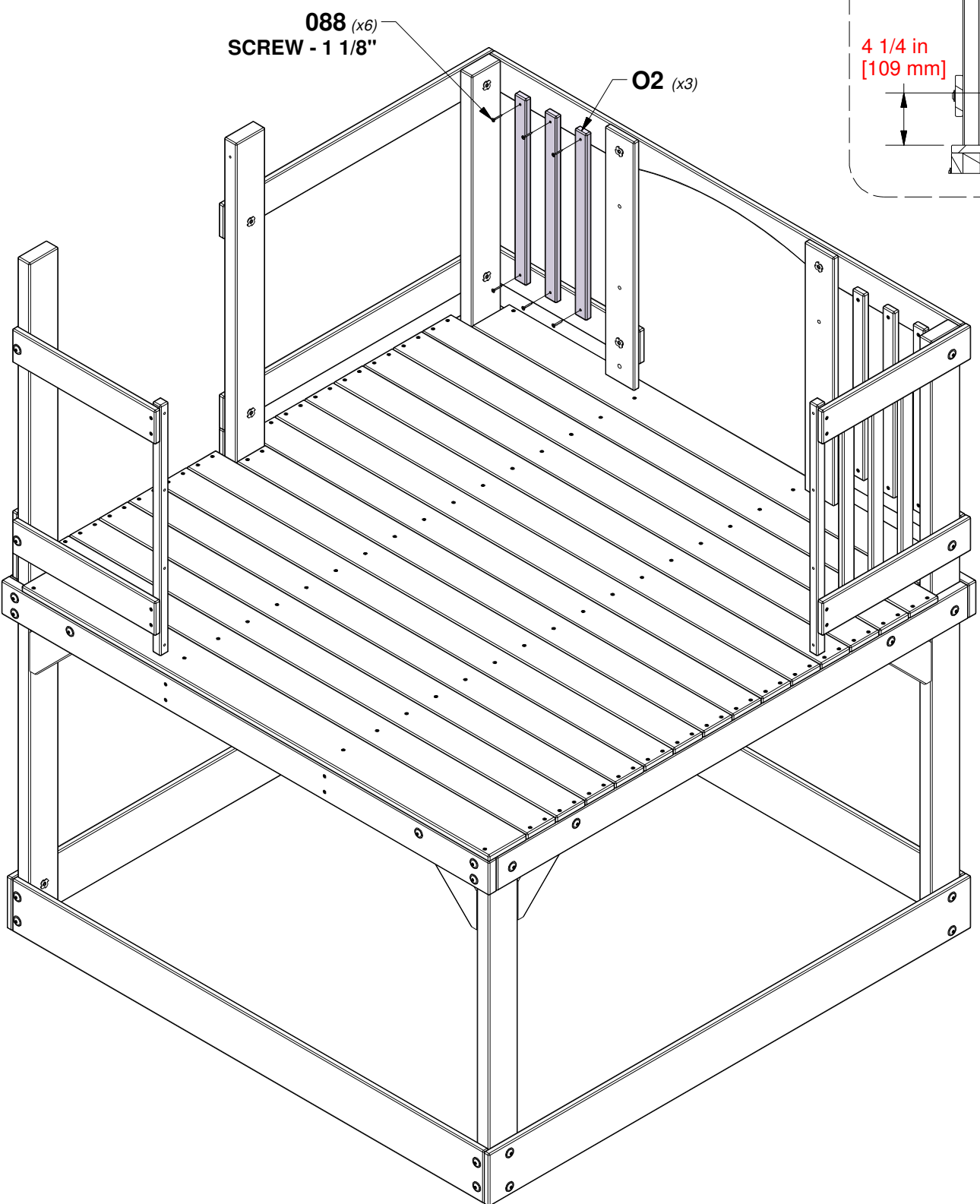

STEP 17 - DECK ASSEMBLY

QTY	PART NUMBER	DESCRIPTION
12	H100088	SCREW PFH 8x1-1/8"



O2 PICKET - W4L06407
 (x6) 5/8"x1 3/8"x18 3/4" (16x34x476)

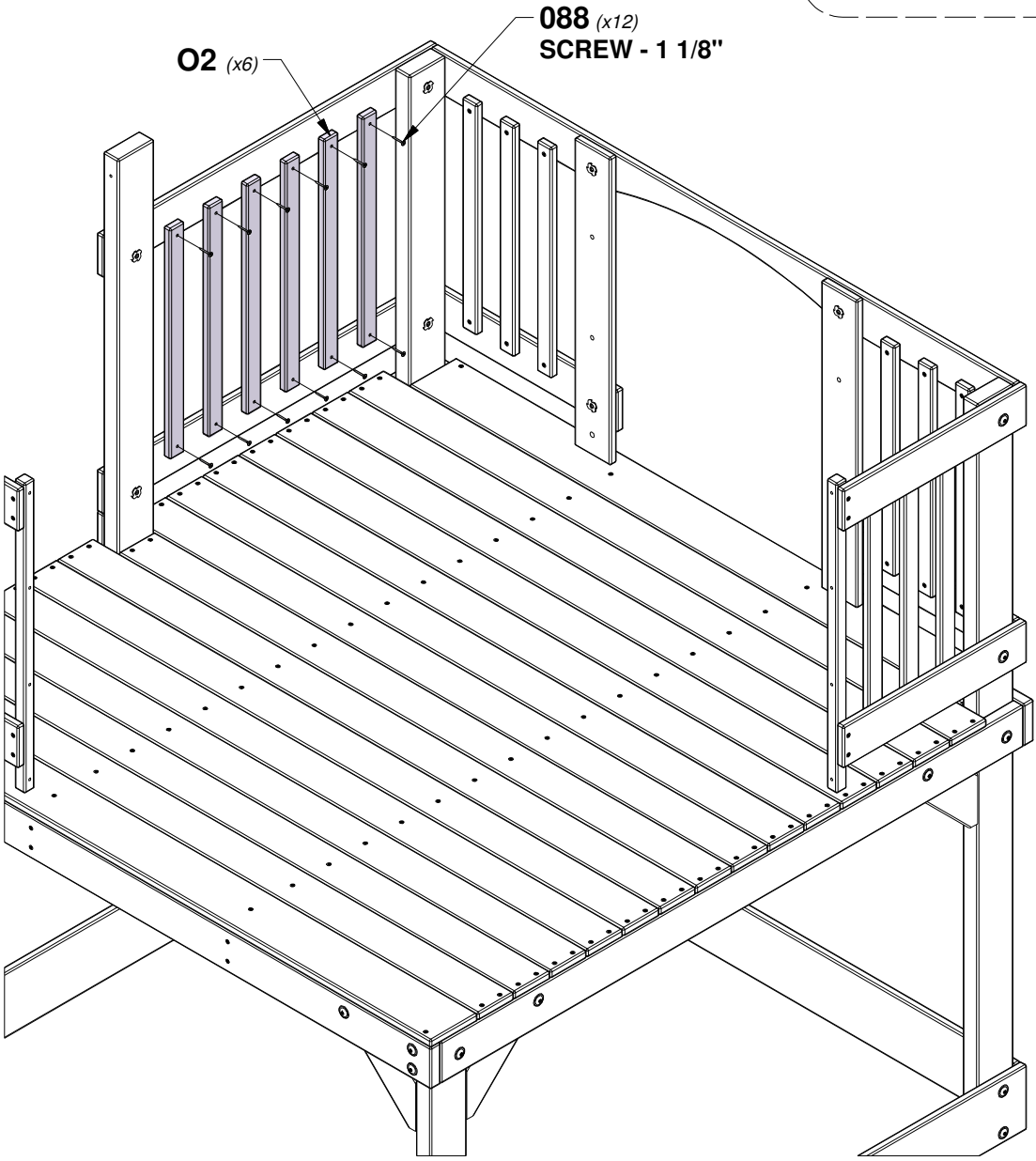
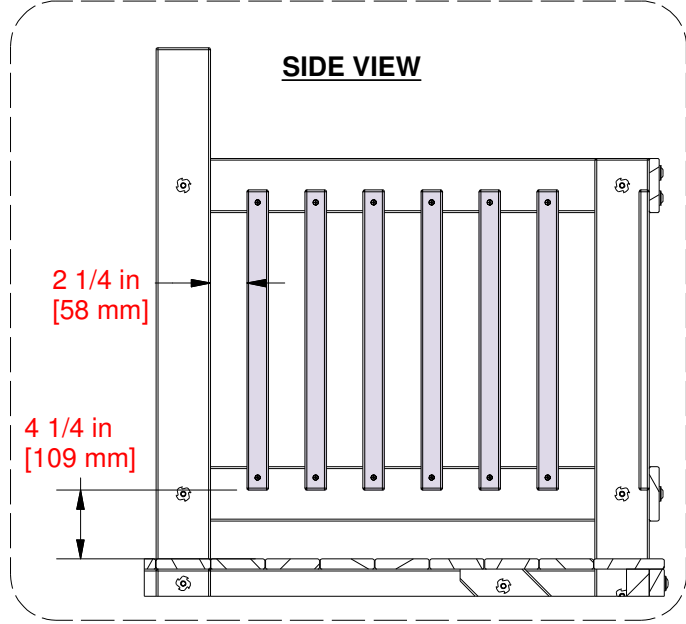

STEP 18 - DECK ASSEMBLY

QTY	PART NUMBER	DESCRIPTION
6	H100088	SCREW PFH 8x1-1/8"



O2 PICKET - W4L06407
(x3) 5/8"x1 3/8"x18 3/4" (16x34x476)

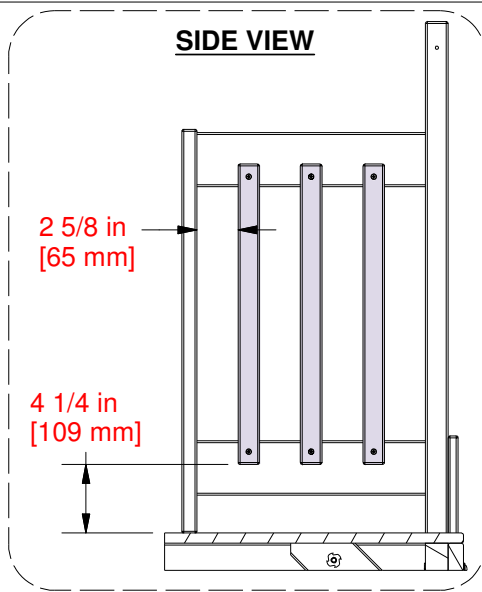
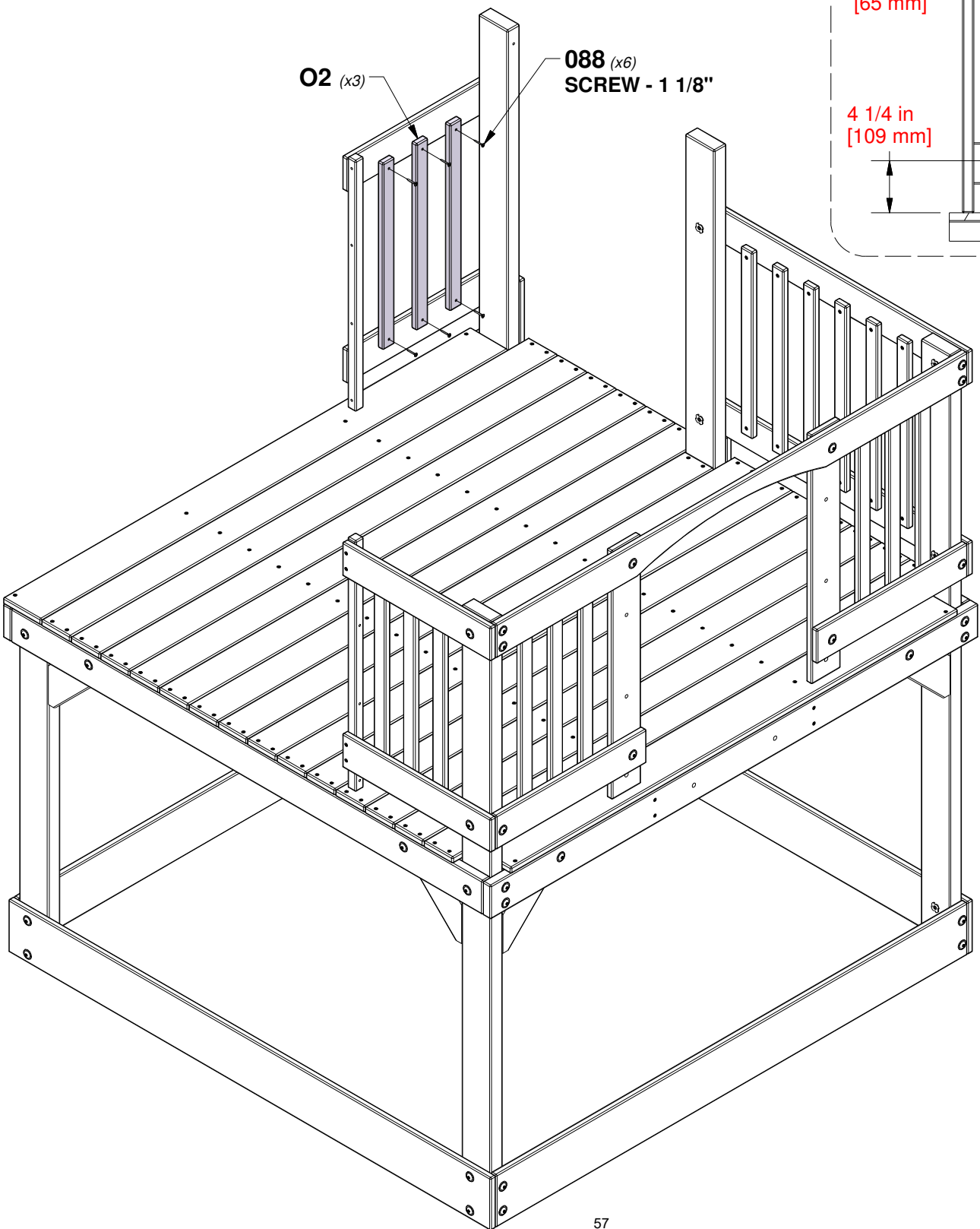

STEP 19 - DECK ASSEMBLY

QTY	PART NUMBER	DESCRIPTION
2	H100199	WASHER LOCK EXT 12x19 BLK
2	H100379	T-NUT 5/16 BLK
4	H100396	BOLT WH 5/16x1/2 BLK
2	H100469	NUT BARREL WH 5/16x5/8 BLK

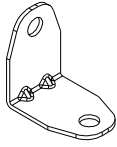

A4M01047 | L BRACKET
(x2) | 2.5x38x55x55

USING BRACKETS AS A GUIDE, DRILL (2) 3/8" (10mm) HOLES THRU FLOOR FOR HARDWARE.

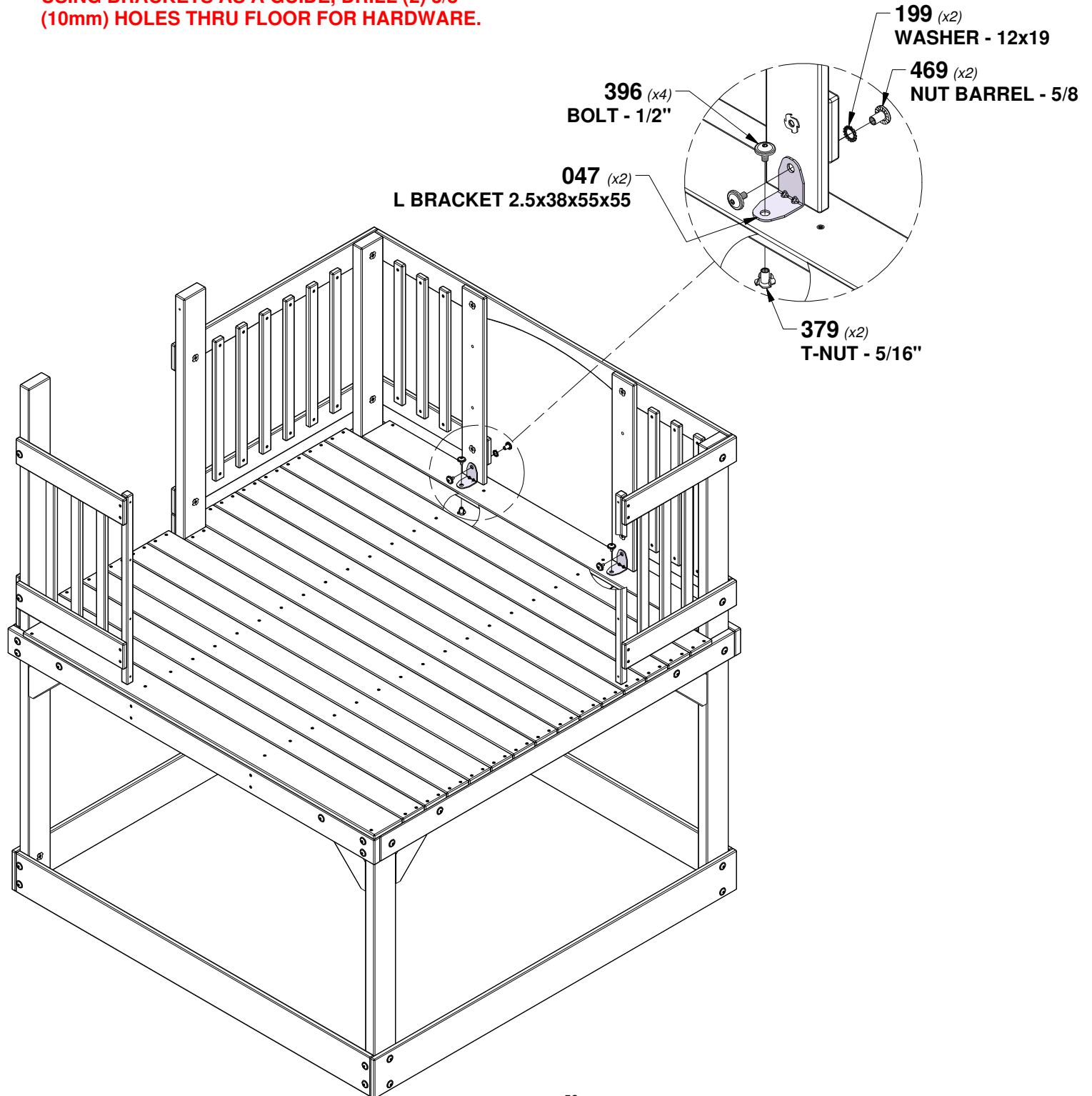

STEP 20 - DECK ASSEMBLY

QTY	PART NUMBER	DESCRIPTION
4	H100171	BOLT WH 1/4x1 BLK
4	H100398	T-NUT 1/4 BLK
4	H100405	WASHER LOCK EXT 6x15 BLK

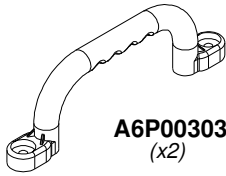

TIP:
INSTALL T-NUTS IN WOOD FIRST

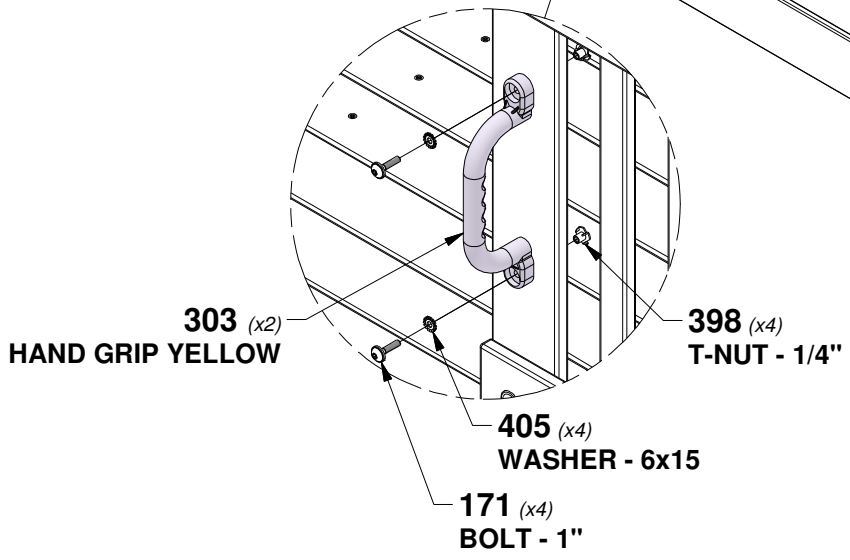
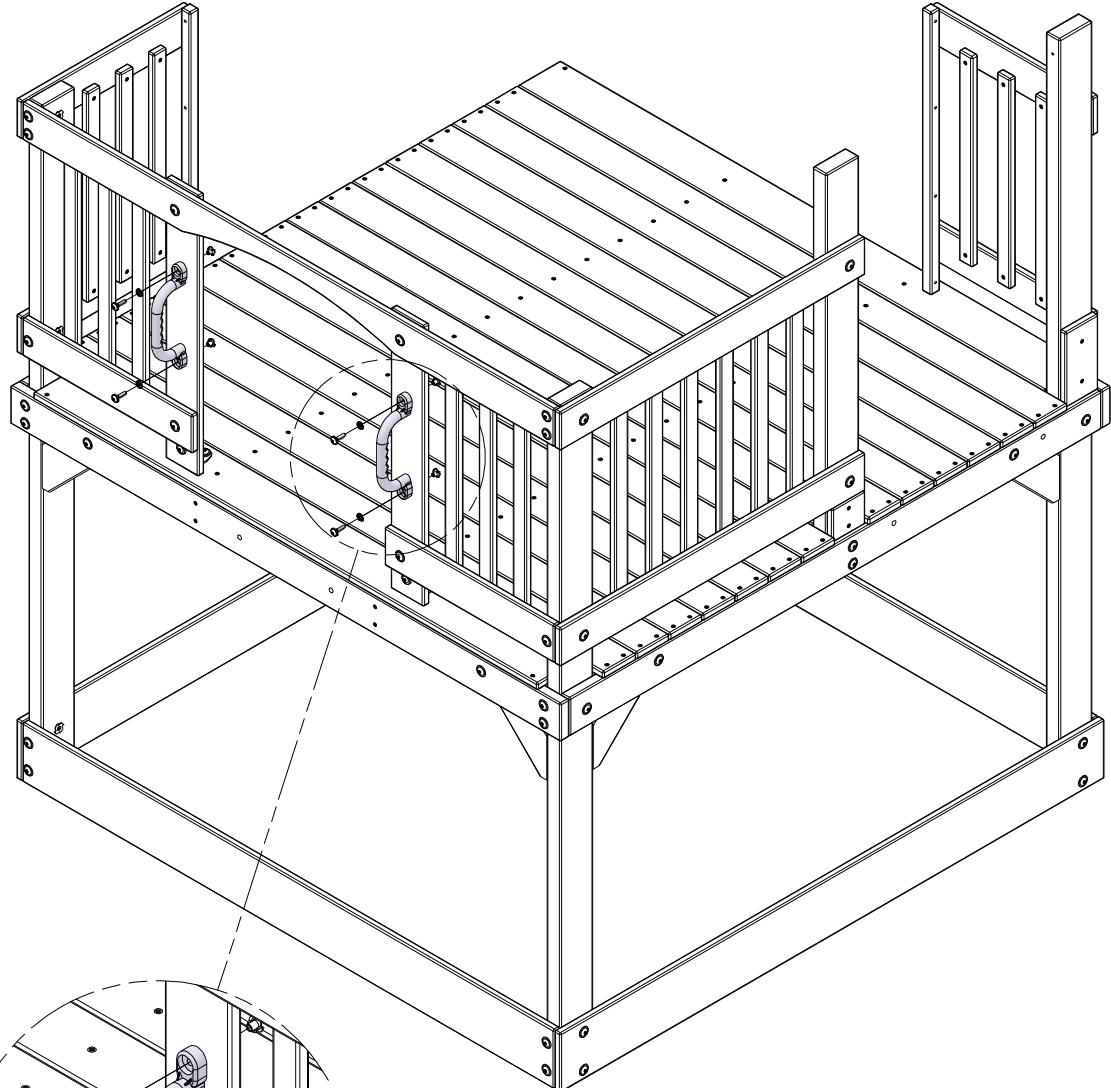

STEP 1 - PLAYHOUSE ASSEMBLY

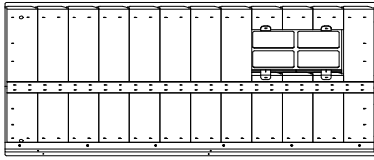

WP1 | FRONT RIGHT CORNER PANEL - W2A03487
(x1)

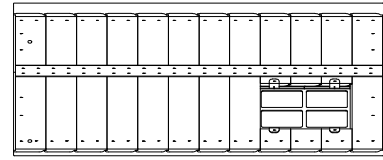

WP2 | REAR RIGHT CORNER PANEL - W2A03490
(x1)

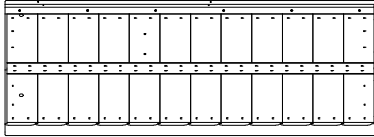

WP3 | FRONT LEFT CORNER PANEL - W2A03493
(x1)

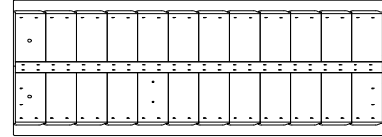

WP4 | REAR LEFT CORNER PANEL - W2A03496
(x1)

STAND THE (4) CORNER ASSEMBLIES AS SHOWN.

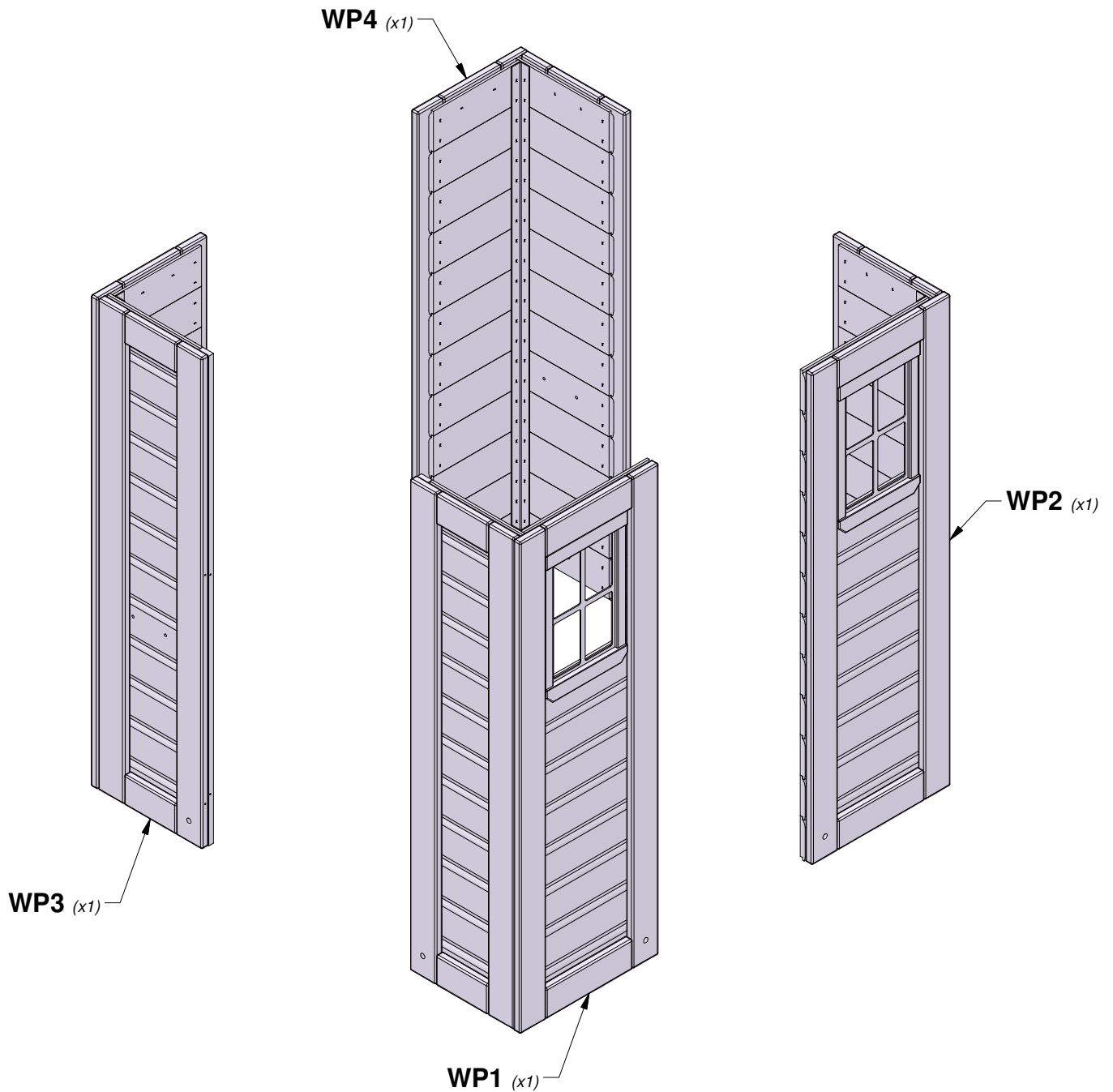

STEP 2 - PLAYHOUSE ASSEMBLY

QTY	PART NUMBER	DESCRIPTION
12	H100085	SCREW PFH 8x1

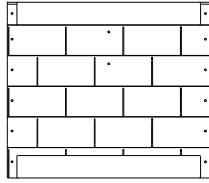

WP6 | LEFT CENTER WALL - W2A03507
(x1) | 1 1/4"x18 1/4"x21 1/8" (32x465x536)

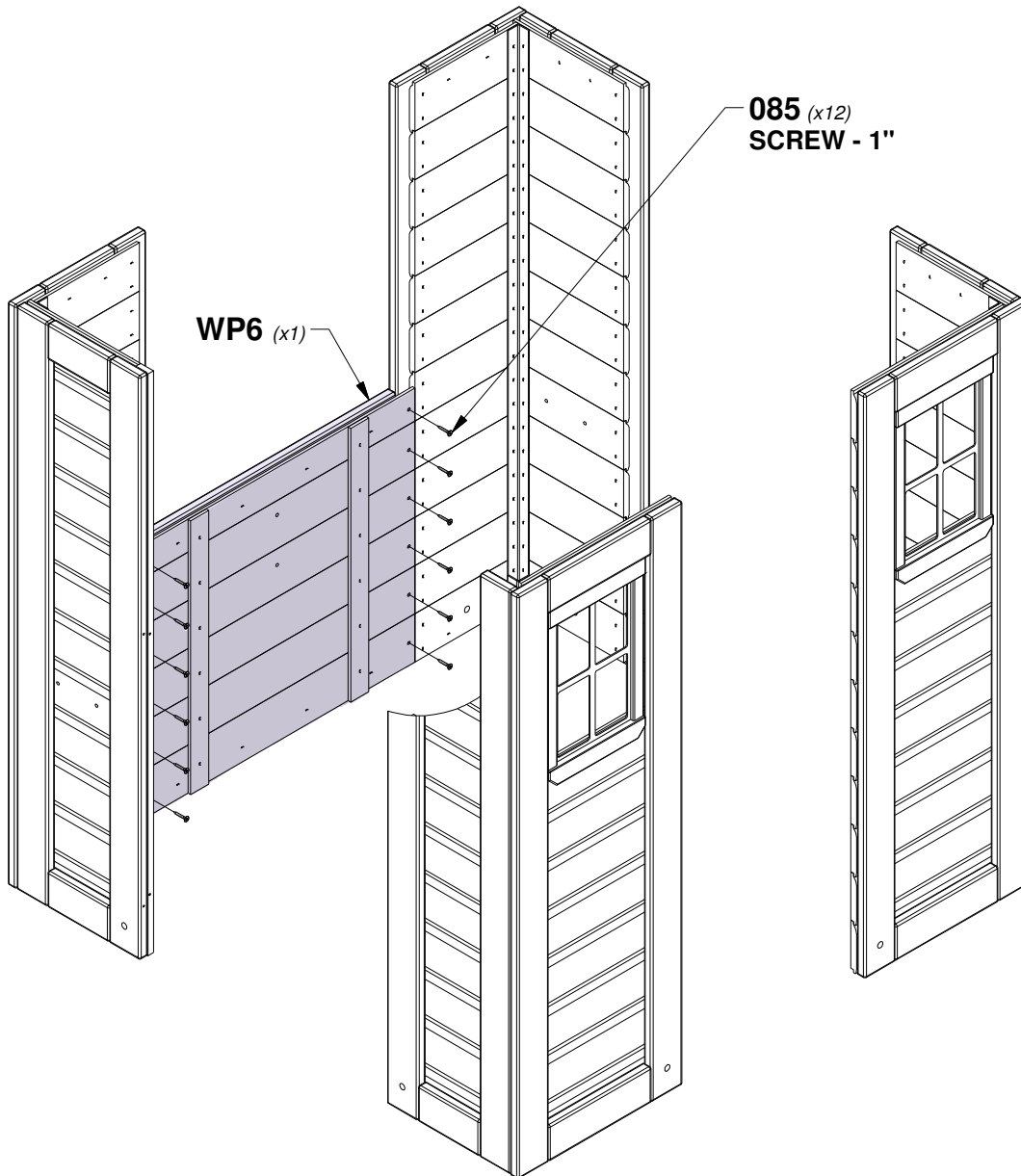

STEP 3 - PLAYHOUSE ASSEMBLY

QTY	PART NUMBER	DESCRIPTION
12	H100085	SCREW PFH 8x1

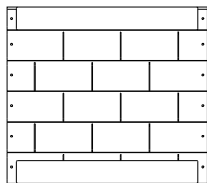

WP5 | REAR CENTER WALL - W2A03506
(x1) | 1 1/4"x18 1/4"x20 7/8" (32x465x530)

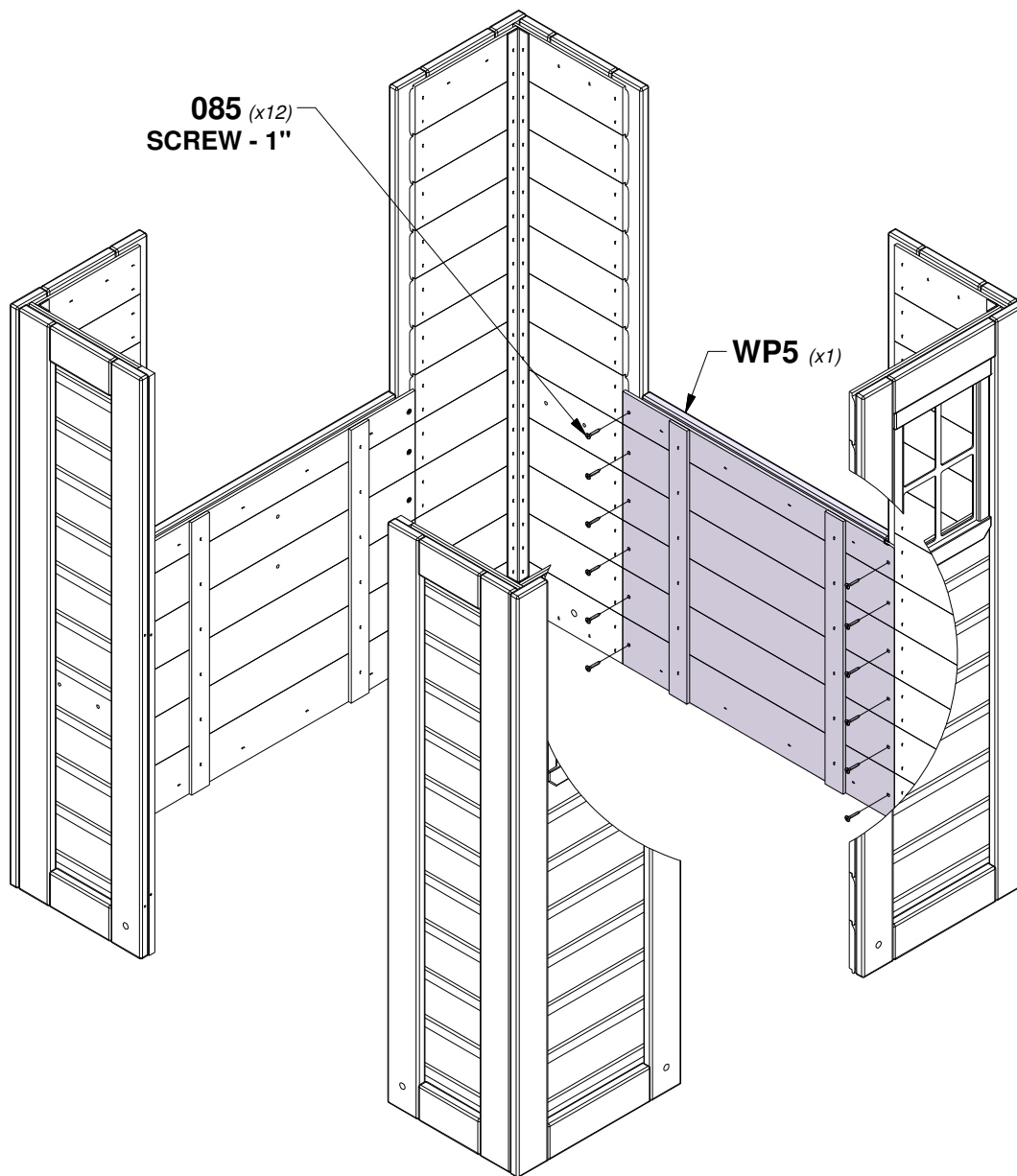

STEP 4 - PLAYHOUSE ASSEMBLY

QTY	PART NUMBER	DESCRIPTION
4	H100090	SCREW PFH 8x2 1/2

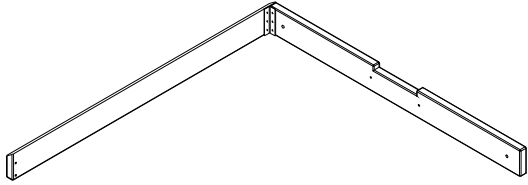

WP8 | HEADER ASSEMBLY - W2A01926
(x2)

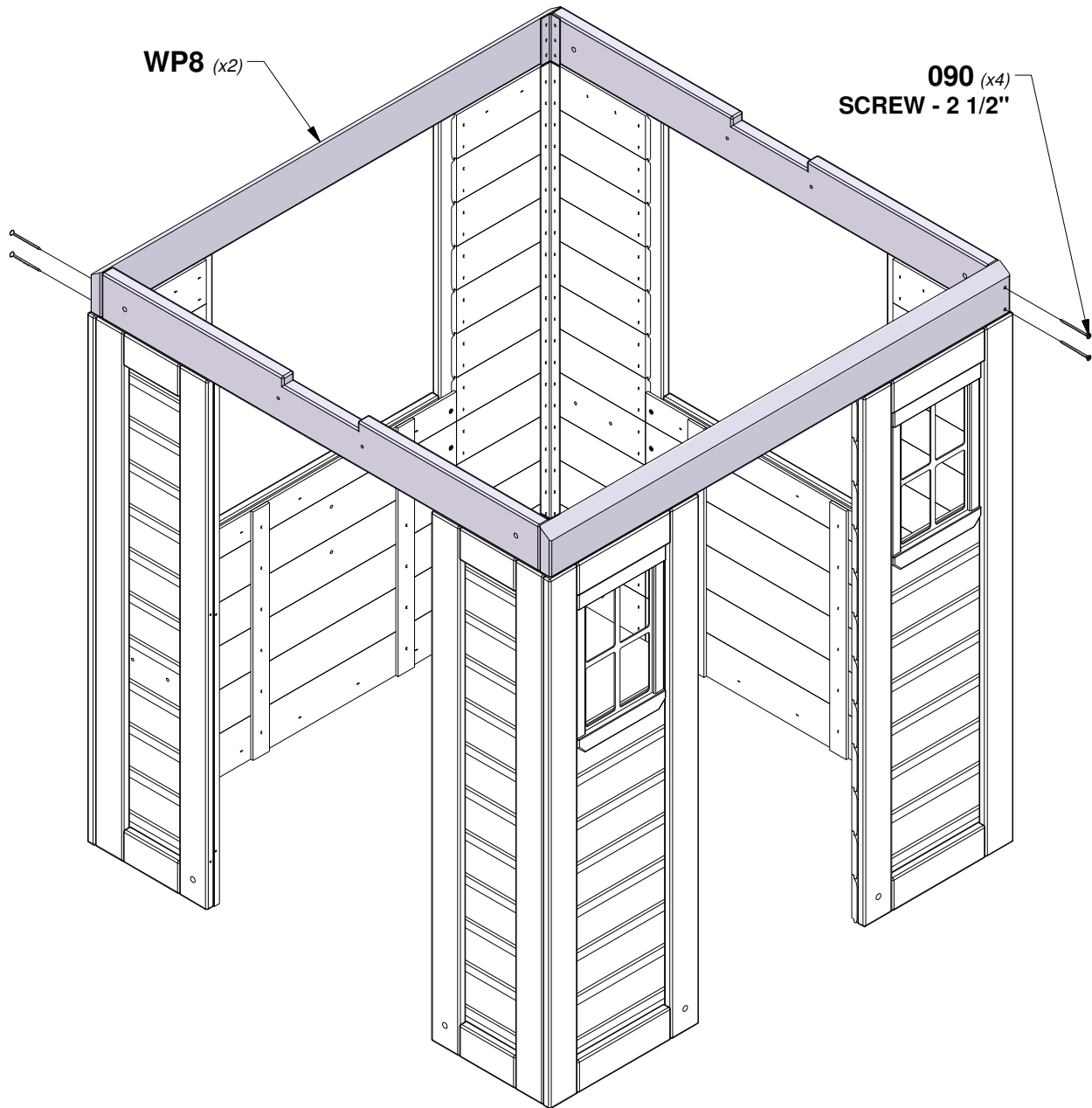

STEP 5 - PLAYHOUSE ASSEMBLY

QTY	PART NUMBER	DESCRIPTION
32	H100087	SCREW PFH 8x1 1/4

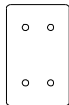

N1 | TIE STRAP - W4L05043
(x8) | 5/8"x2"x3 1/8" (16x50x80)

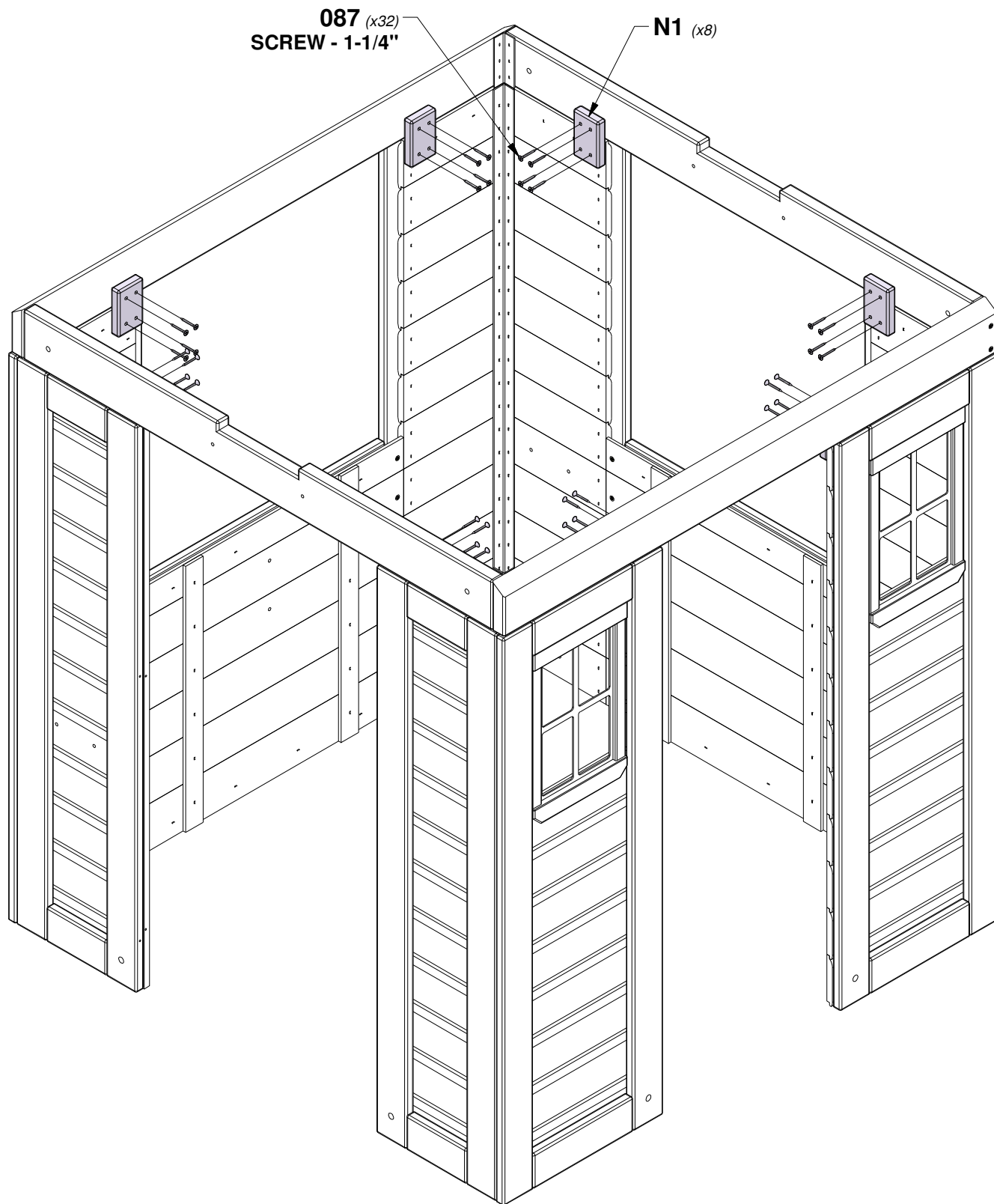

STEP 6 - PLAYHOUSE ASSEMBLY

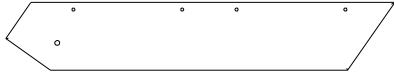

L3 | GABLE BOARD - W4L06412
 (x4) | 5/8"x4 3/8"x25 3/8" (16x112x644)

QTY	PART NUMBER	DESCRIPTION
4	H100398	T-NUT 1/4 BLK
4	H100405	WASHER LOCK EXT 6x15 BLK
4	H100406	BOLT WH 1/4x1 1/2 BLK

TIP:
INSTALL T-NUTS IN WOOD FIRST

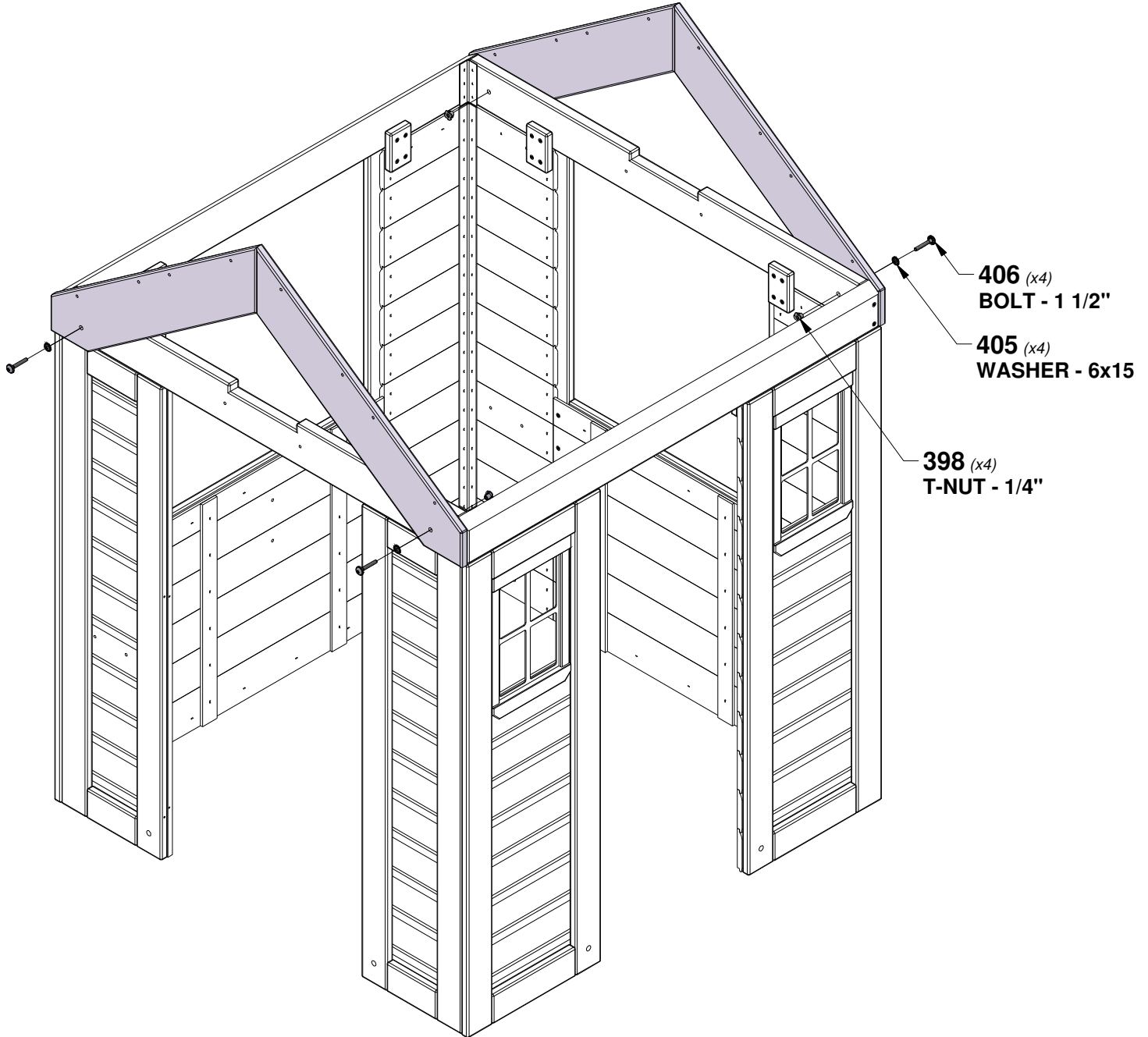

STEP 7 - PLAYHOUSE ASSEMBLY

QTY	PART NUMBER	DESCRIPTION
8	H100070	SCREW PWH 8x3/4
4	H100087	SCREW PFH 8x1-1/4"

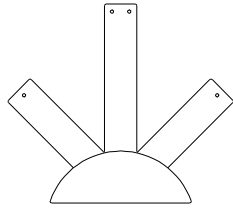

A100361 | PLASTIC SUNBURST
(x2)

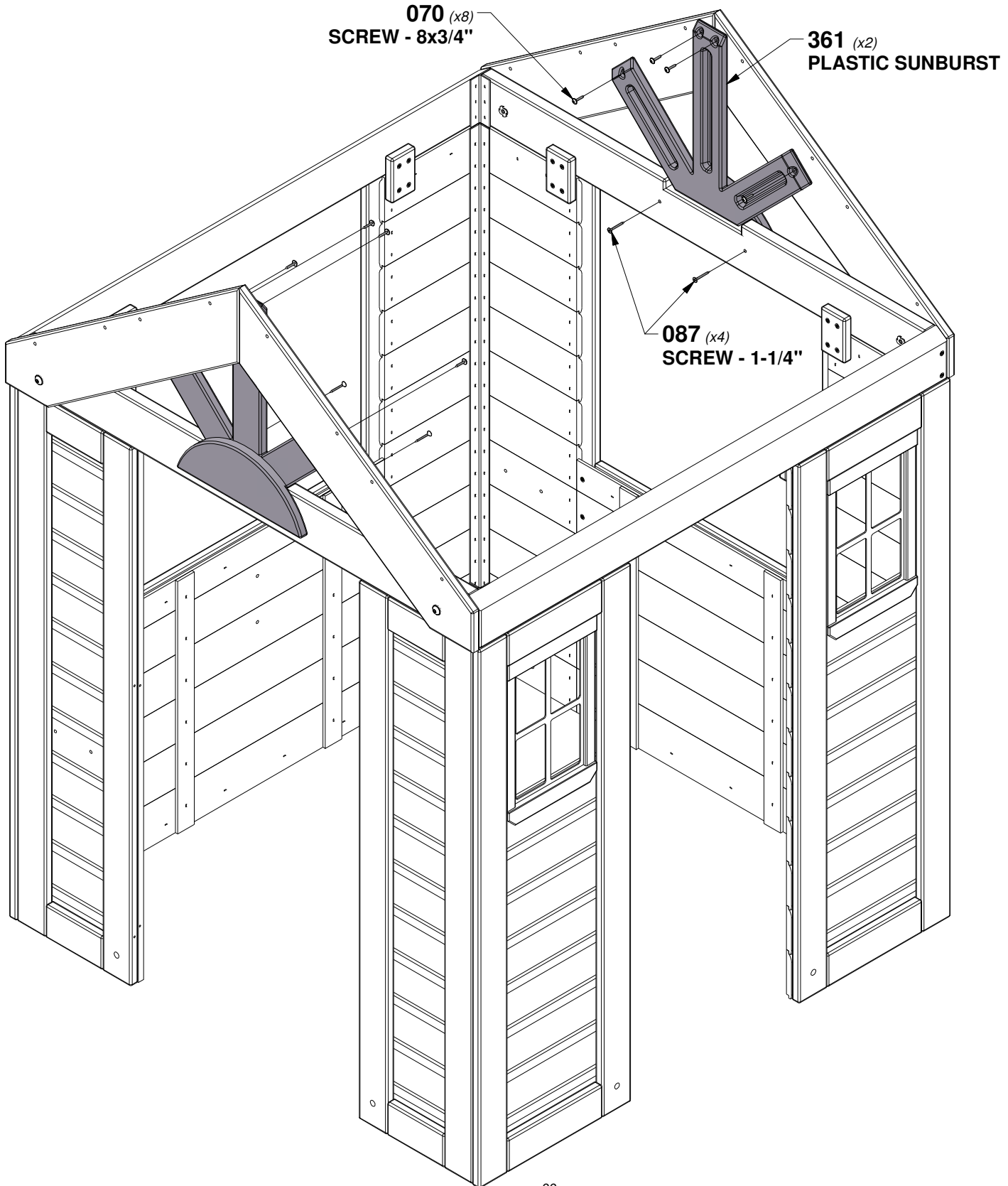

STEP 8 - PLAYHOUSE ASSEMBLY

QTY	PART NUMBER	DESCRIPTION
8	H100086	SCREW PFH 8x1-1/2"

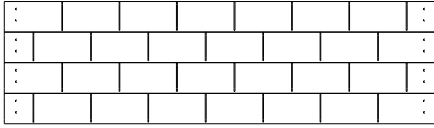

RP2 | UPPER ROOF PANEL - W2A01930
 (x2) | 1 3/8"x12 3/4"x44 7/8" (35x324x1140)

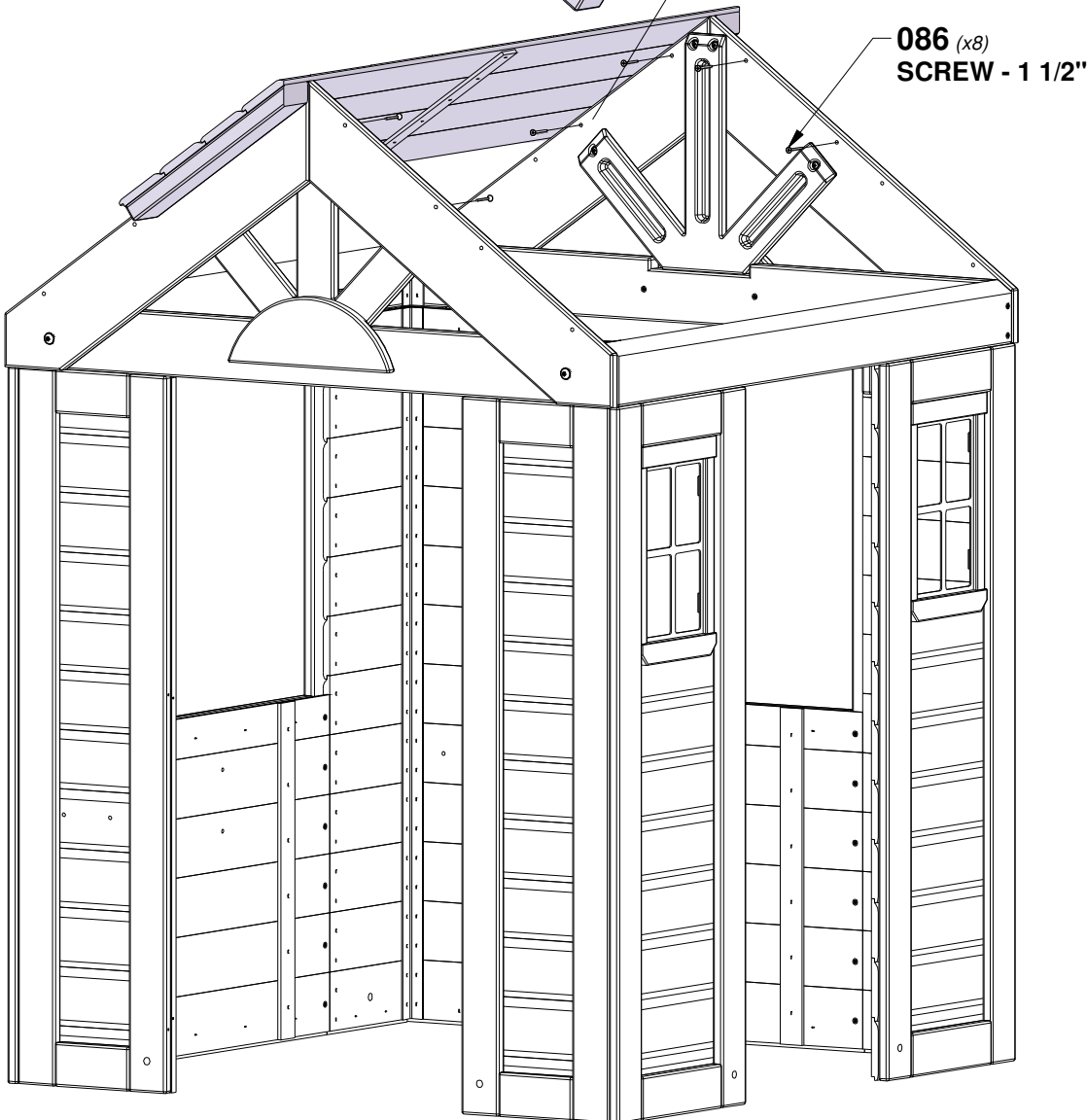
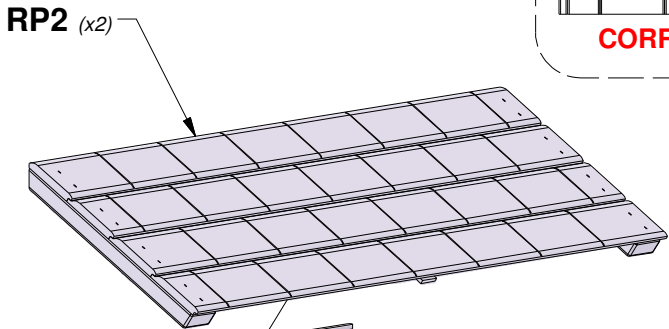
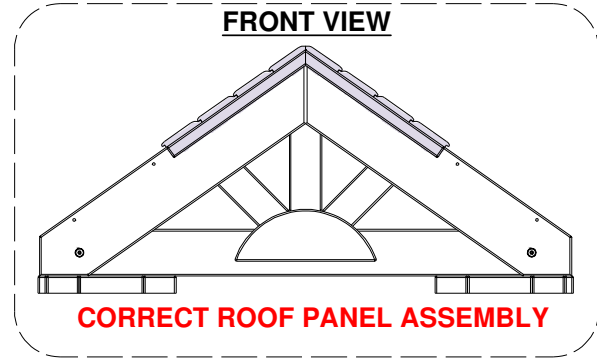

STEP 9 - PLAYHOUSE ASSEMBLY

QTY	PART NUMBER	DESCRIPTION
8	H100086	SCREW PFH 8x1-1/2"

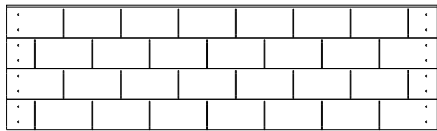

RP1 | LOWER ROOF PANEL - W2A01929
(x2) | 1 3/8"x12 15/16"x44 7/8" (35x329x1140)

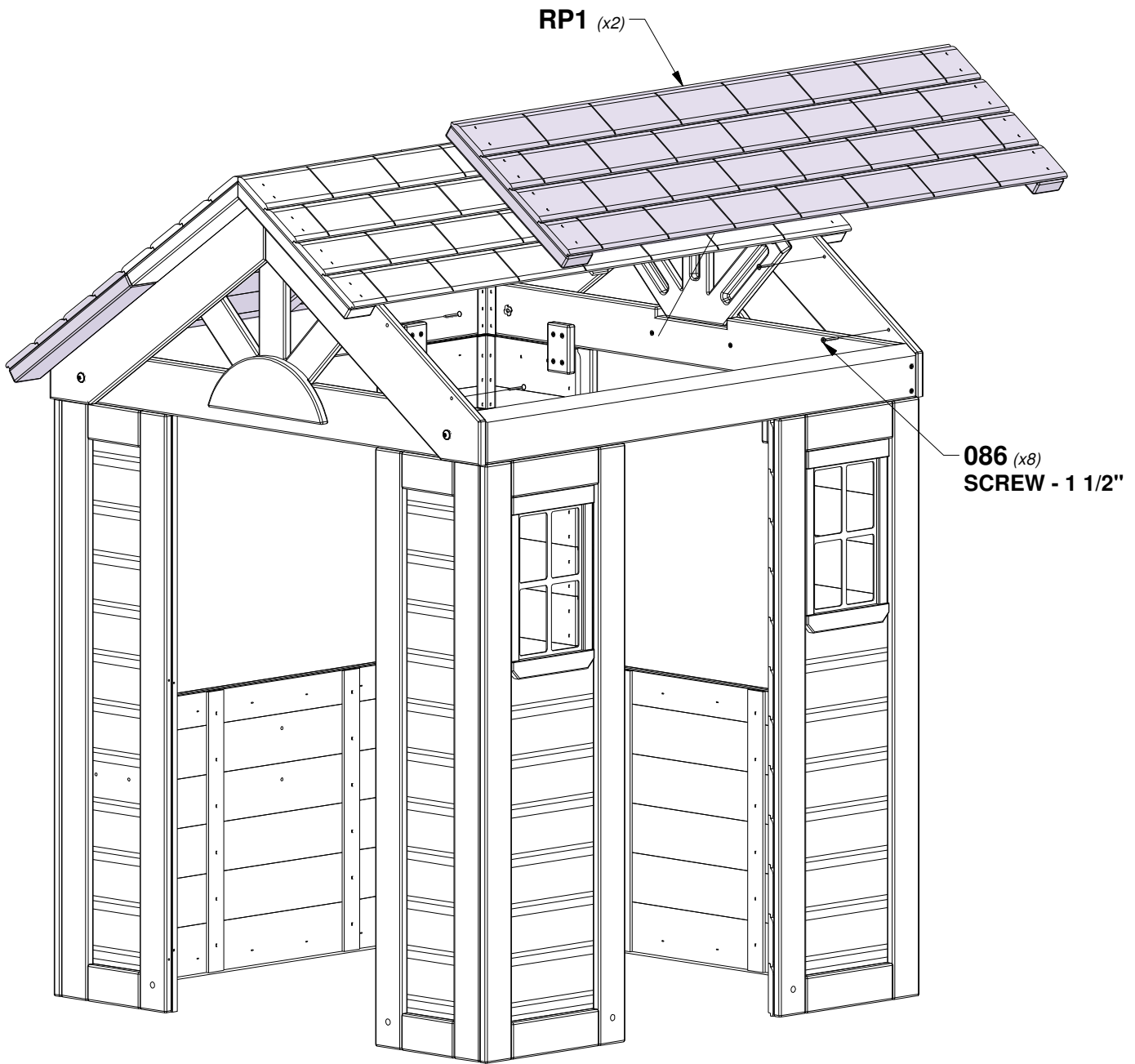

STEP 10 - PLAYHOUSE ASSEMBLY

QTY	PART NUMBER	DESCRIPTION
2	H100087	SCREW PFH 8x1-1/4"



N3 | LEFT WINDOW SHELF - W4L06415
(x1) | 5/8"x2 3/8"x19 1/8" (16x60x485)

TIP:
ALIGN BOARD THEN PRE-DRILL USING AN 1/8" [3mm] DRILL BIT.

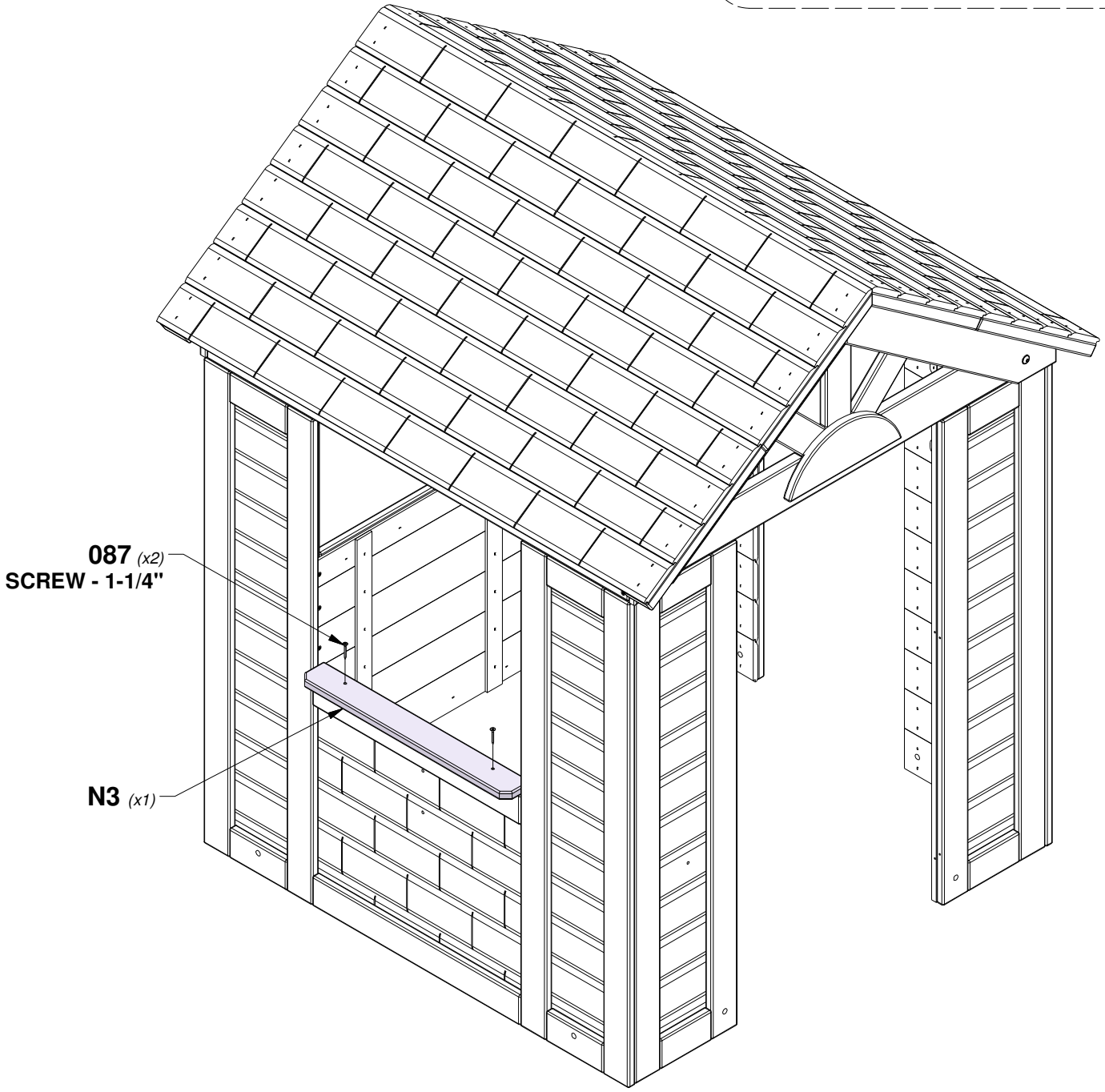
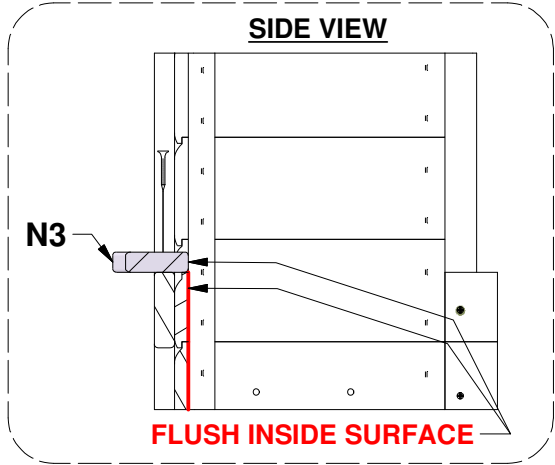

087 (x2)
SCREW - 1-1/4"

N3 (x1)

STEP 11 - PLAYHOUSE ASSEMBLY

QTY	PART NUMBER	DESCRIPTION
2	H100087	SCREW PFH 8x1-1/4"

N2 | REAR WINDOW SHELF - W4L06414
(x1) | 5/8"x2 3/8"x18 7/8" (16x60x479)

TIP:
ALIGN BOARD THEN PRE-DRILL USING AN 1/8" [3mm] DRILL BIT.

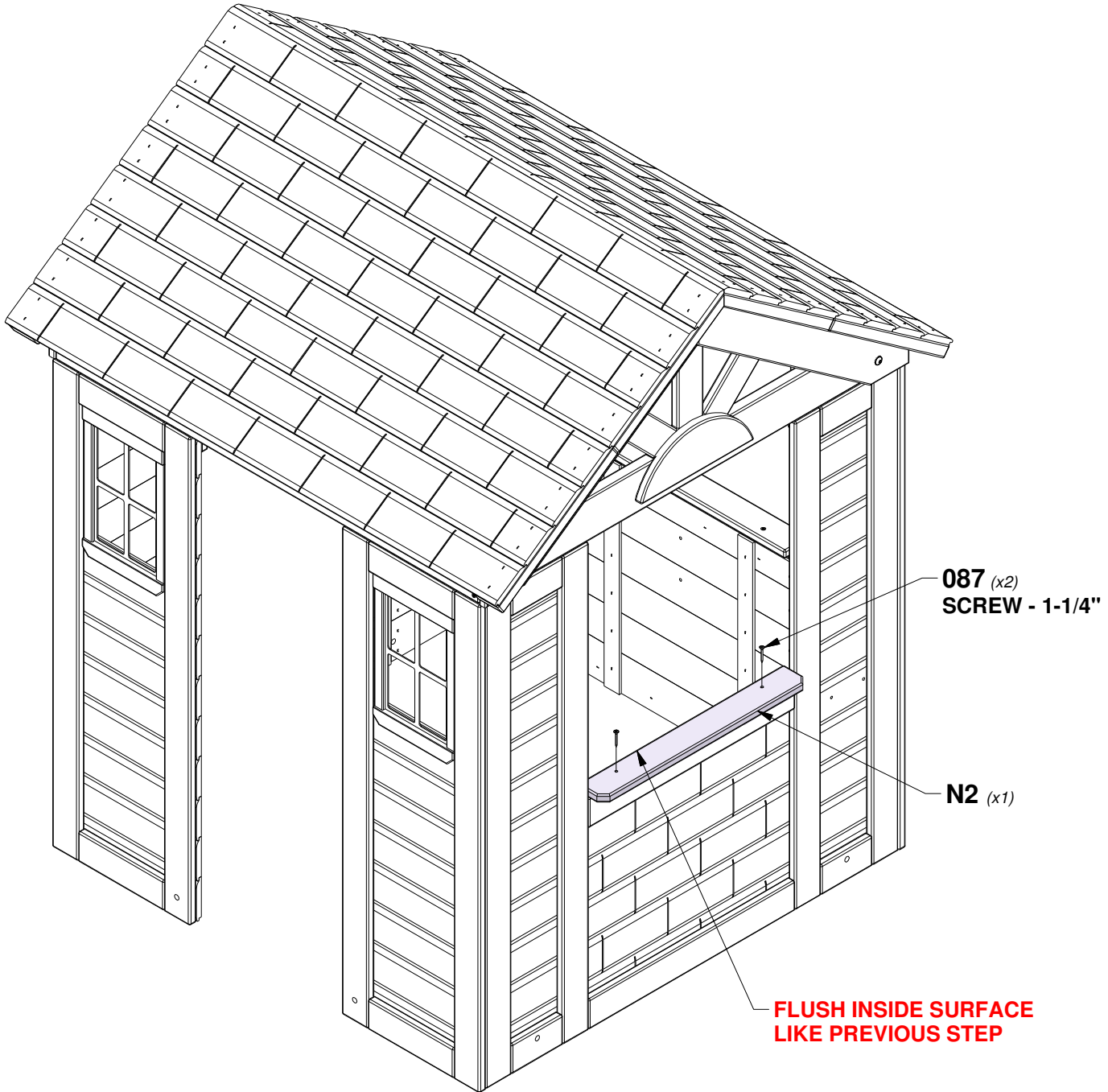

STEP 12 - PLAYHOUSE ASSEMBLY

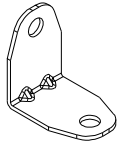

A4M01047
(x8) | **L BRACKET 2.5x38x55x55**

QTY	PART NUMBER	DESCRIPTION
8	H100192	NUT BARREL WH 5/16x7/8 BLK
8	H100663	BOLT WH 5/16x3/4 BLK

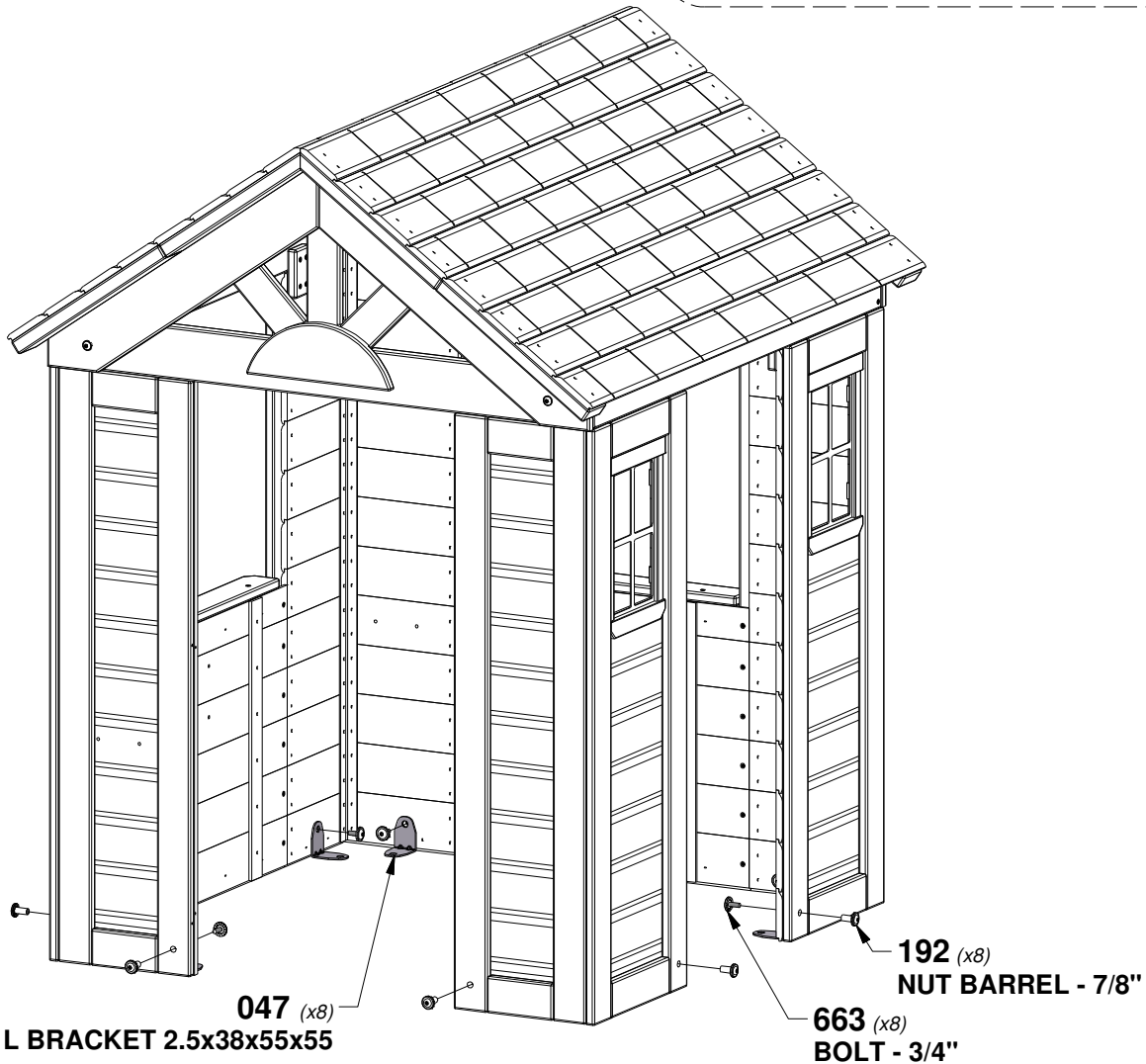
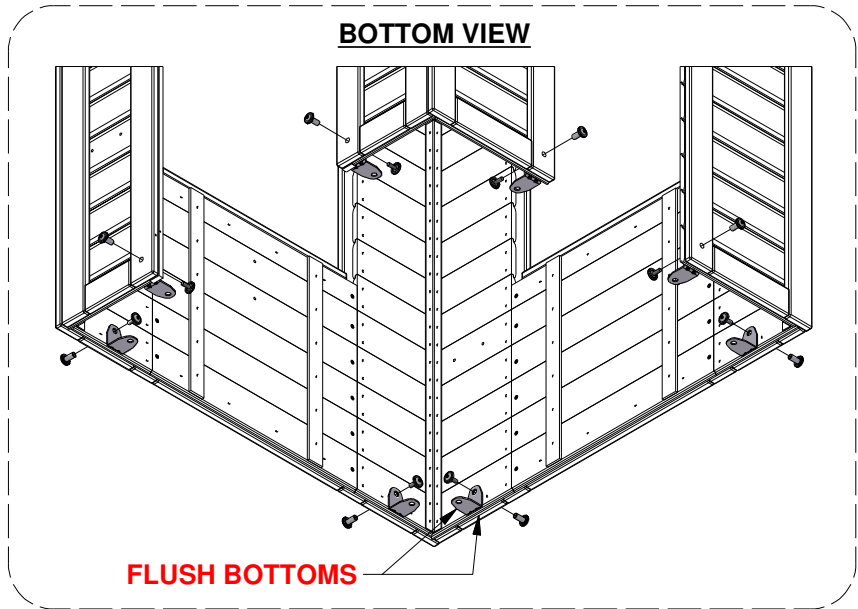

STEP 13 - PLAYHOUSE ASSEMBLY

QTY	PART NUMBER	DESCRIPTION
2	H100200	SCREW PFH 8x1-1/2 BLK

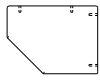

Q1 | COUNTER TOP SUPPORT - W4L16911
(x1) | 1"x4 3/8"x5 7/8" (24x112x150)

NOTE:
ALIGN PILOT HOLES IN BOARD WITH PILOT HOLES IN WALL PANEL.

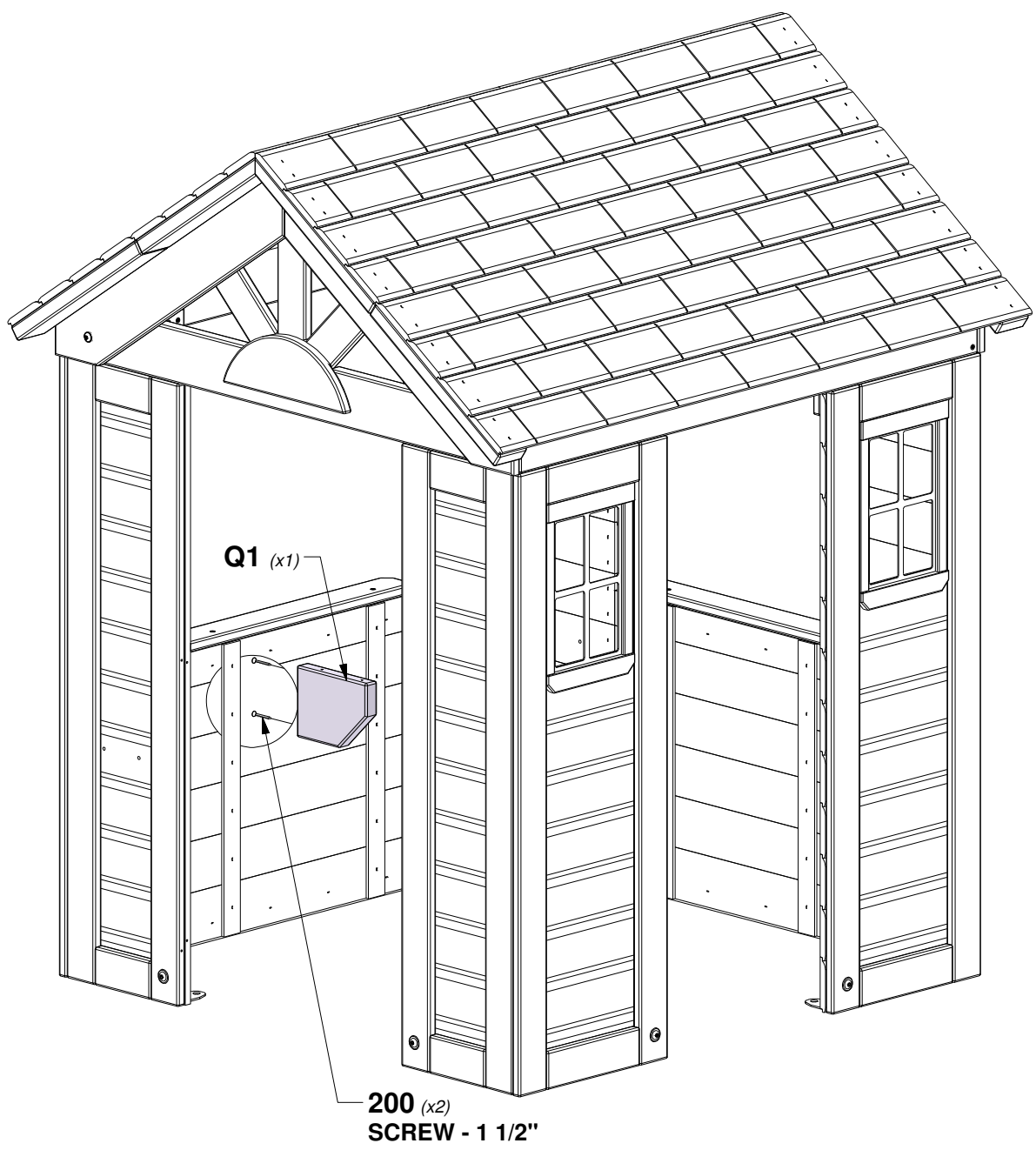

STEP 14 - PLAYHOUSE ASSEMBLY

QTY	PART NUMBER	DESCRIPTION
4	H100087	SCREW PFH 8x1-1/4"

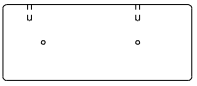

J2 | COUNTER TOP SUPPORT - W4L16909
(x2) | 1"x2 3/8"x5 7/8" (24x60x150)

NOTE:
ALIGN PILOT HOLES IN BOARD WITH PILOT HOLES IN WALL PANEL.

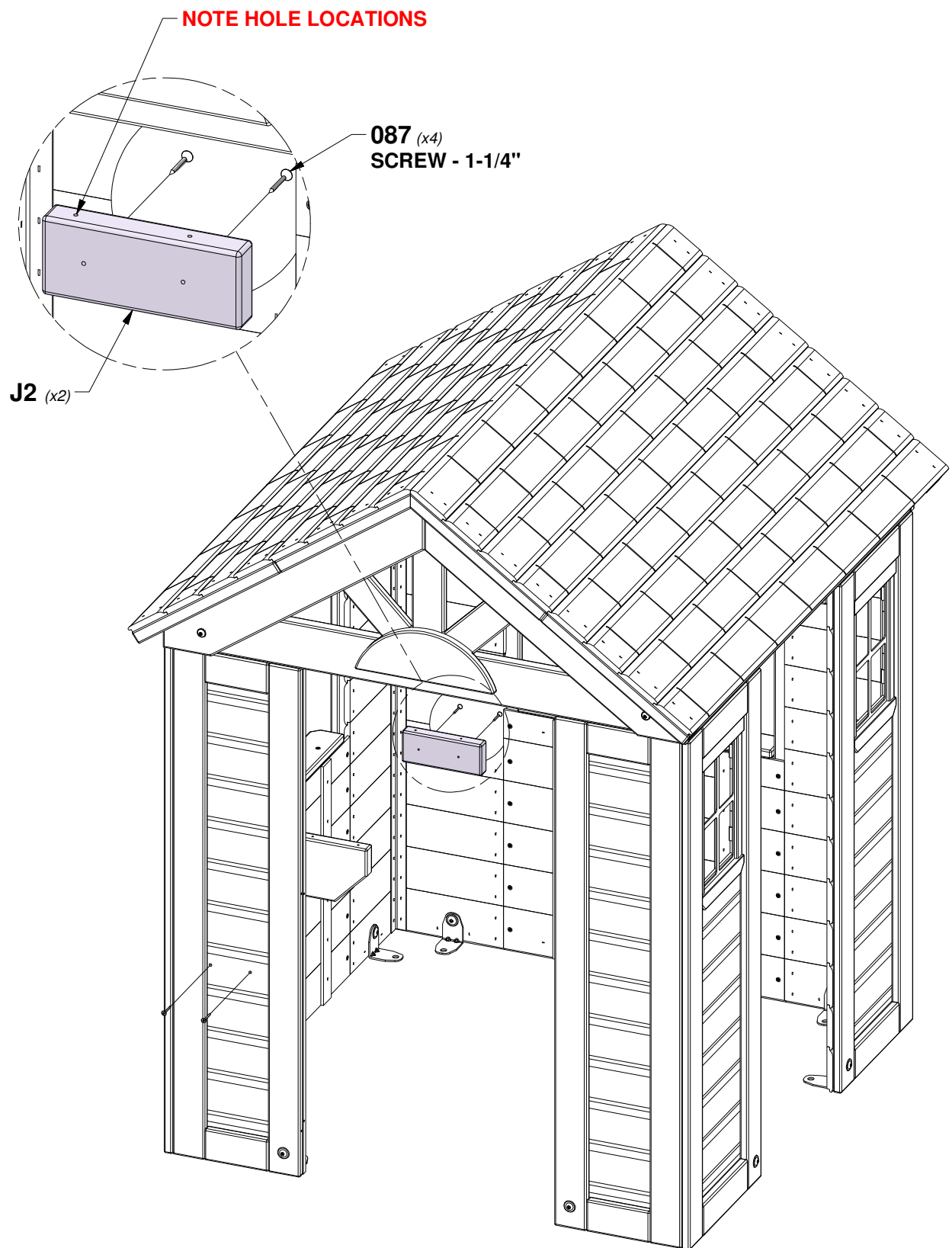

STEP 15 - PLAYHOUSE ASSEMBLY

QTY	PART NUMBER	DESCRIPTION
6	H100087	SCREW PFH 8x1-1/4"



M10 | COUNTER TOP - W4L16910
(x2) | 5/8"x3 3/8"x36 7/8" (16x86x936)

NOTE:
ALIGN PILOT HOLES IN BOARD WITH PILOT HOLES IN SUPPORTS.

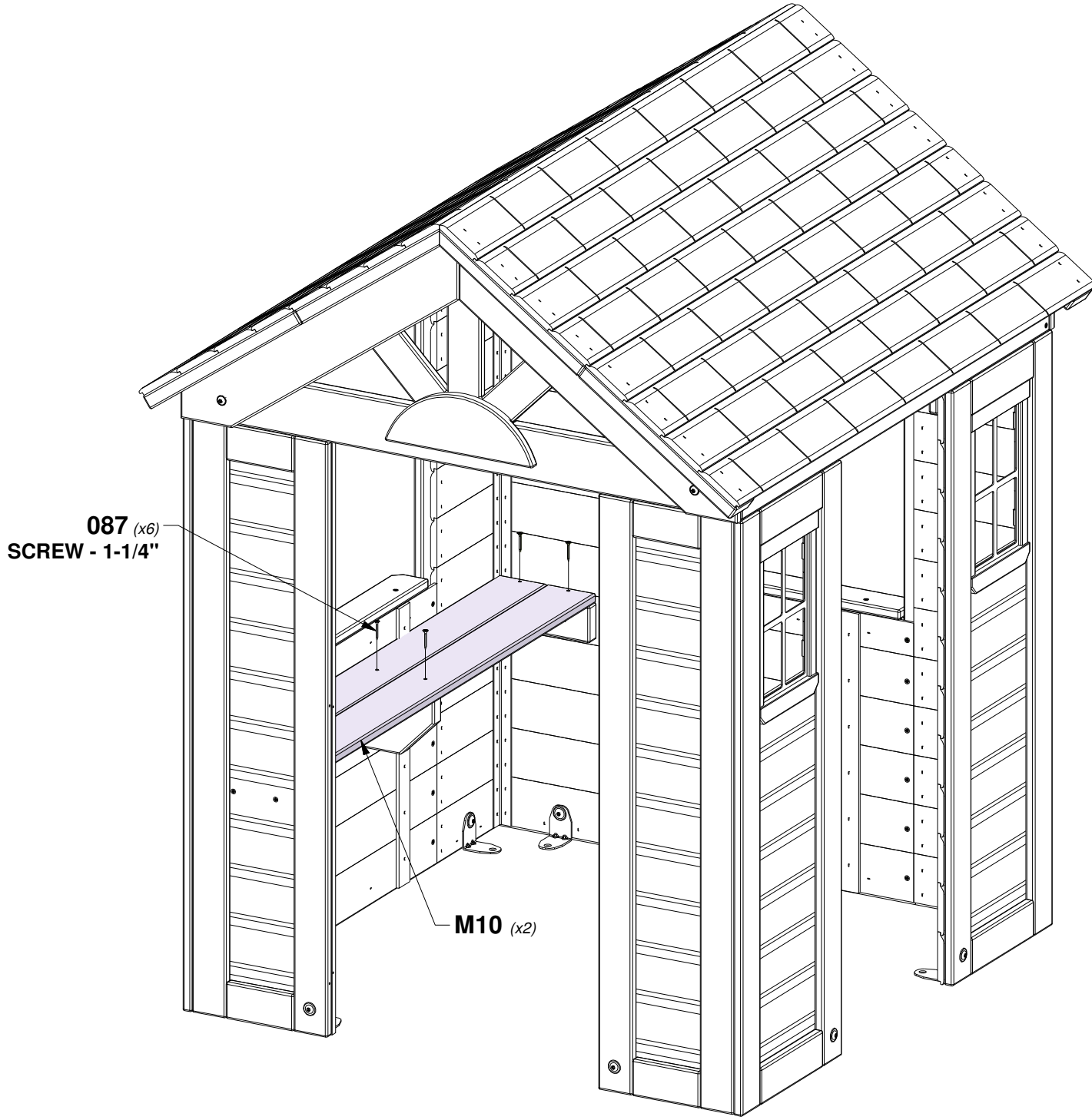

STEP 16 - PLAYHOUSE ASSEMBLY

QTY	PART NUMBER	DESCRIPTION
2	H100086	SCREW PFH 8x1-1/2"

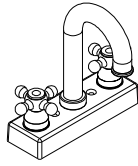

A6P00024 | FAUCET KIT
(x1)

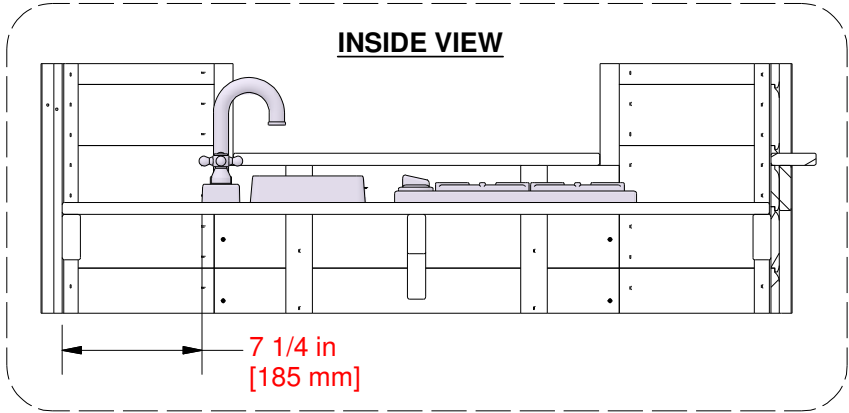

086 (x2)
SCREW - 1 1/2"

024 (x1)
FAUCET KIT

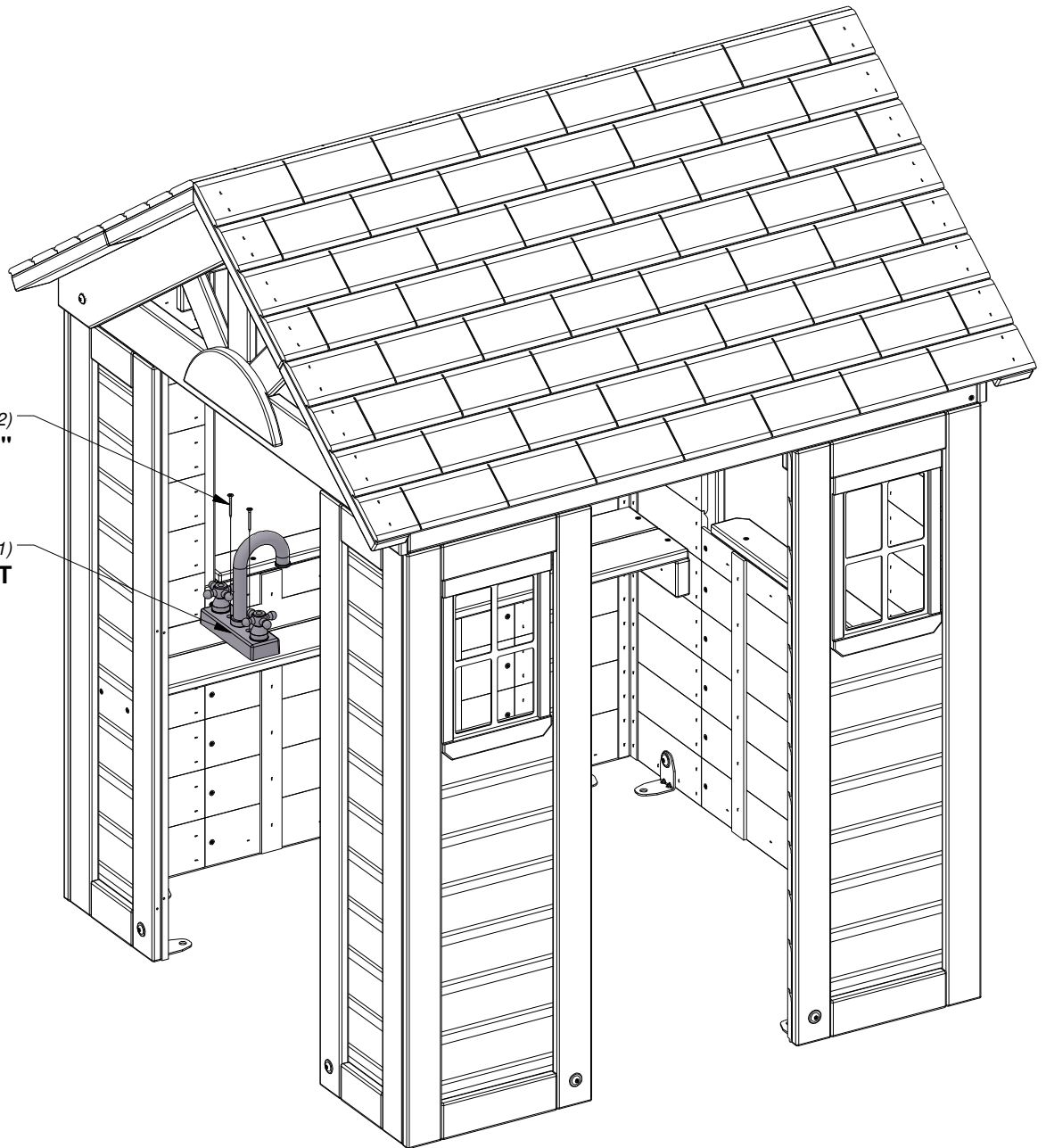

STEP 17 - PLAYHOUSE ASSEMBLY

QTY	PART NUMBER	DESCRIPTION
2	H100128	SCREW PWH 8x5/8

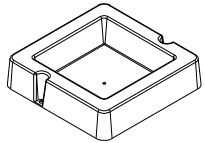

A6P00032 | SURFACE MOUNT BASIN
(x1)

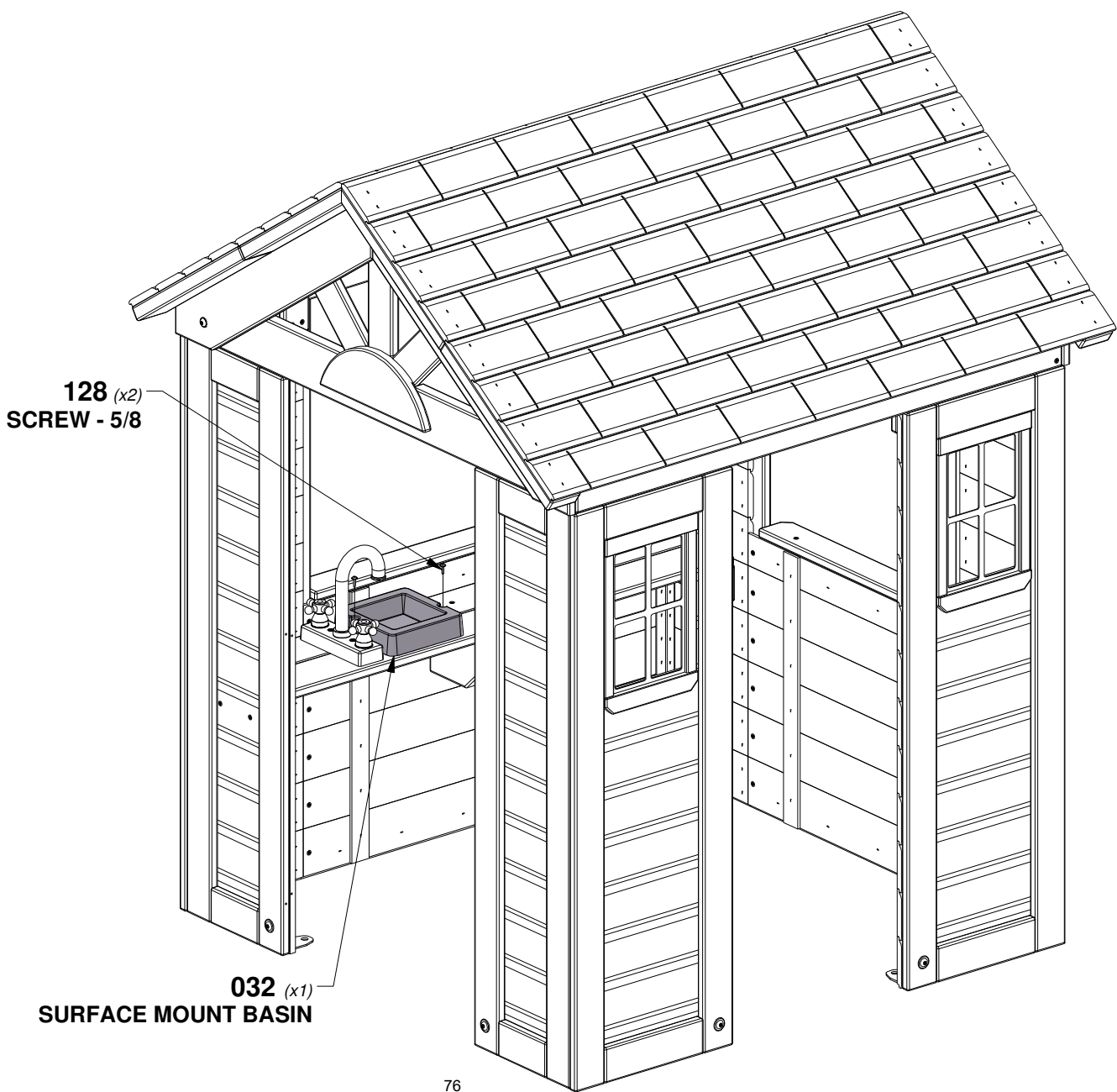
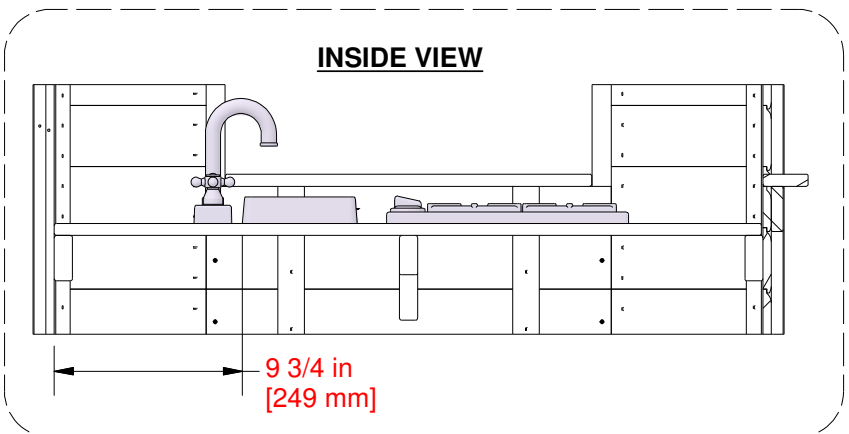

STEP 18 - PLAYHOUSE ASSEMBLY

QTY	PART NUMBER	DESCRIPTION
4	H100088	SCREW PFH 8x1-1/8"

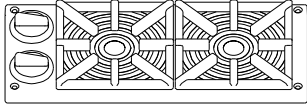

A6P00025 | STOVE KIT
(x1)

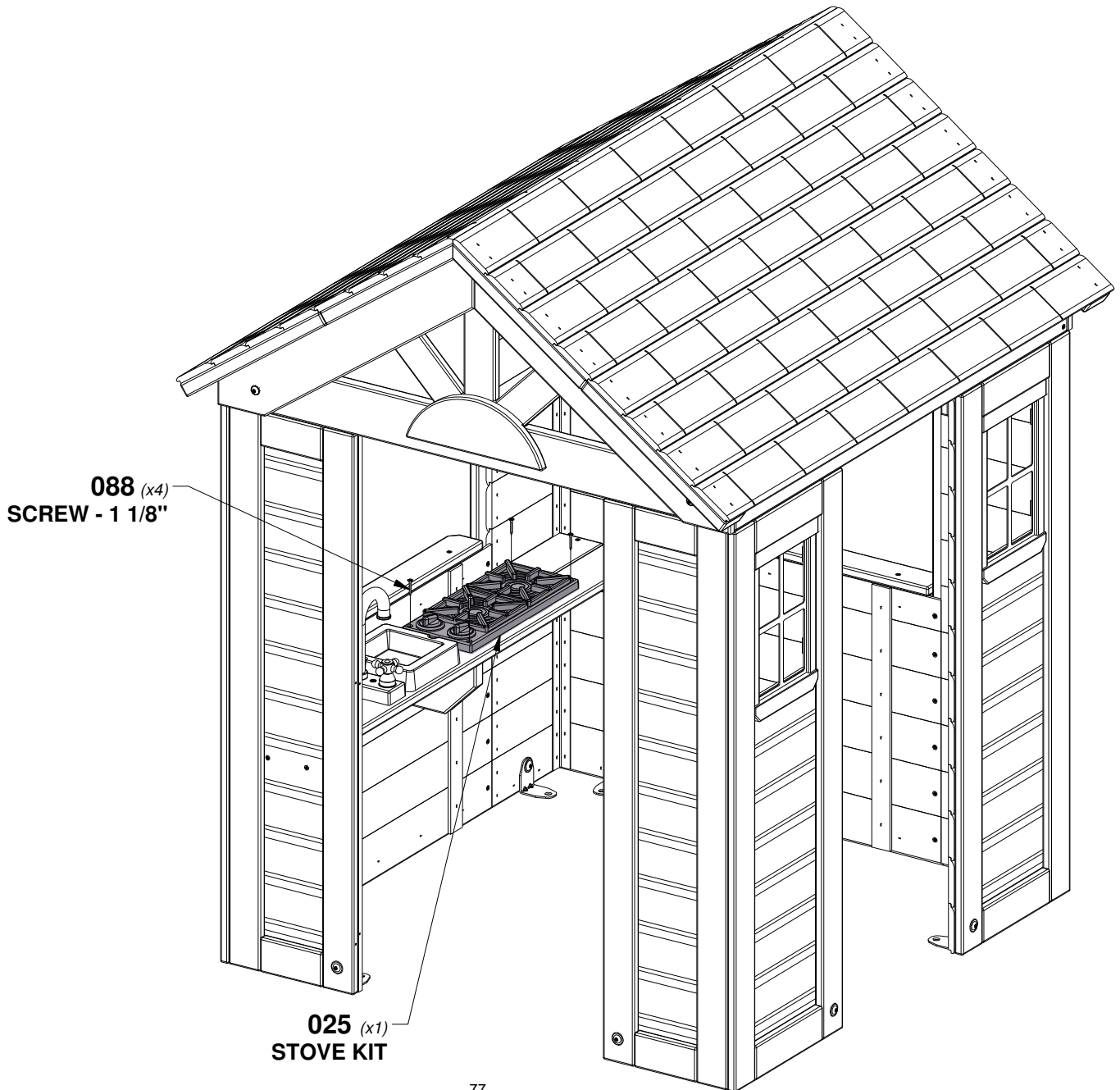
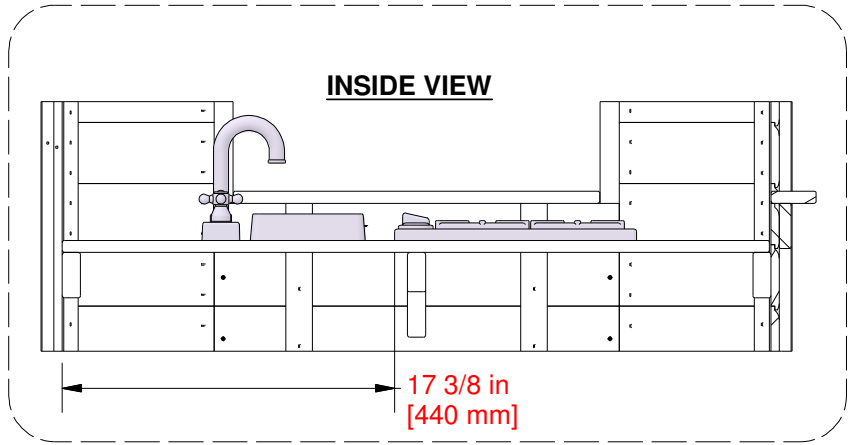

STEP 19 - PLAYHOUSE ASSEMBLY

QTY	PART NUMBER	DESCRIPTION
4	H100387	SCREW PFH 8x1-1/4 BLK

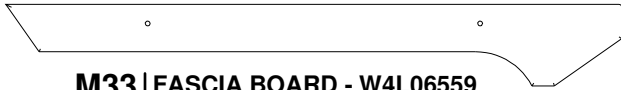

M33 | FASCIA BOARD - W4L06559
(x2) | 5/8"x3 3/8"x25 5/8" (16x86x652)

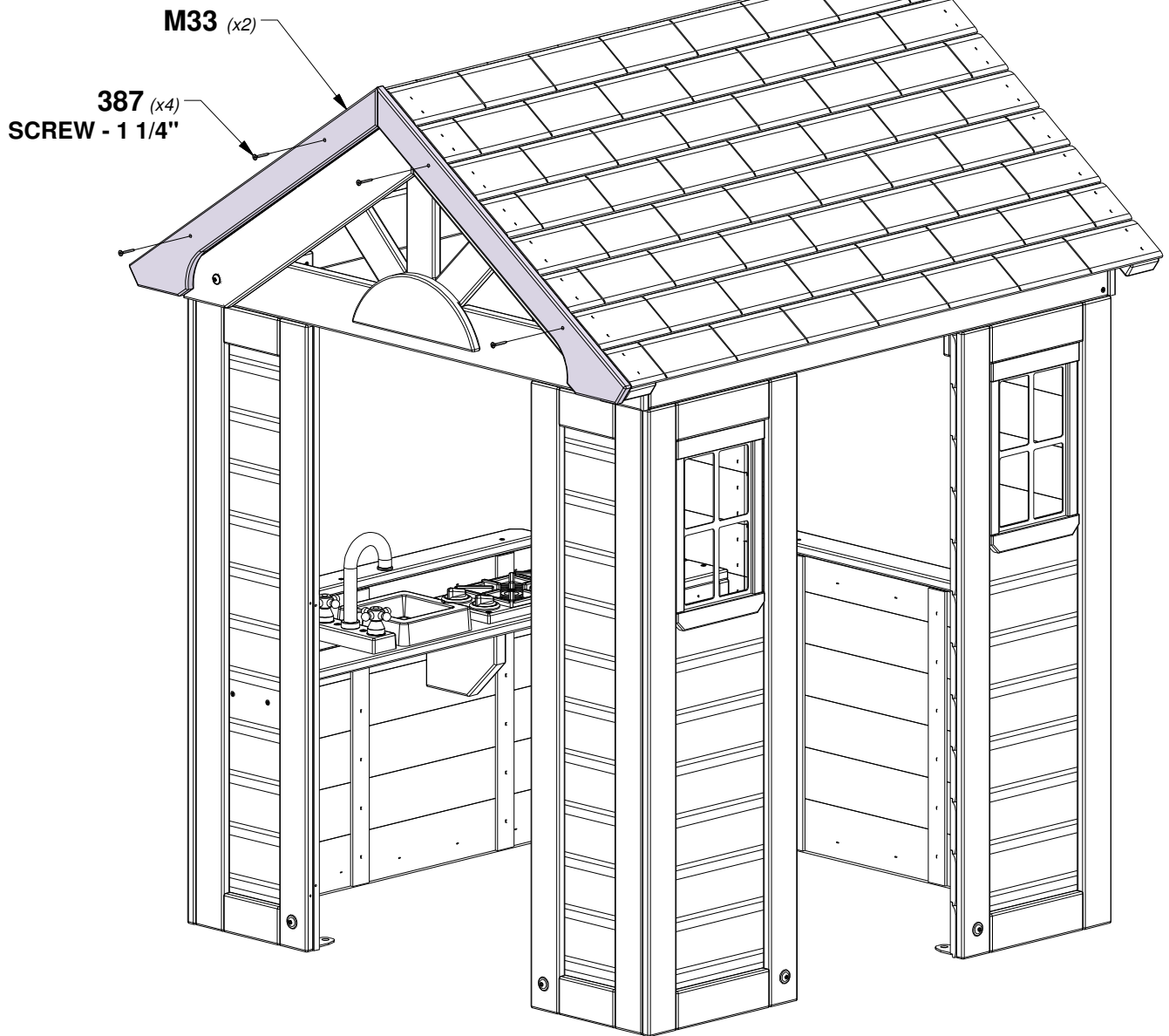

STEP 20 - PLAYHOUSE ASSEMBLY

QTY	PART NUMBER	DESCRIPTION
4	H100387	SCREW PFH 8x1-1/4 BLK



M33 | FASCIA BOARD - W4L06559
(x2) | 5/8"x3 3/8"x25 5/8" (16x86x652)

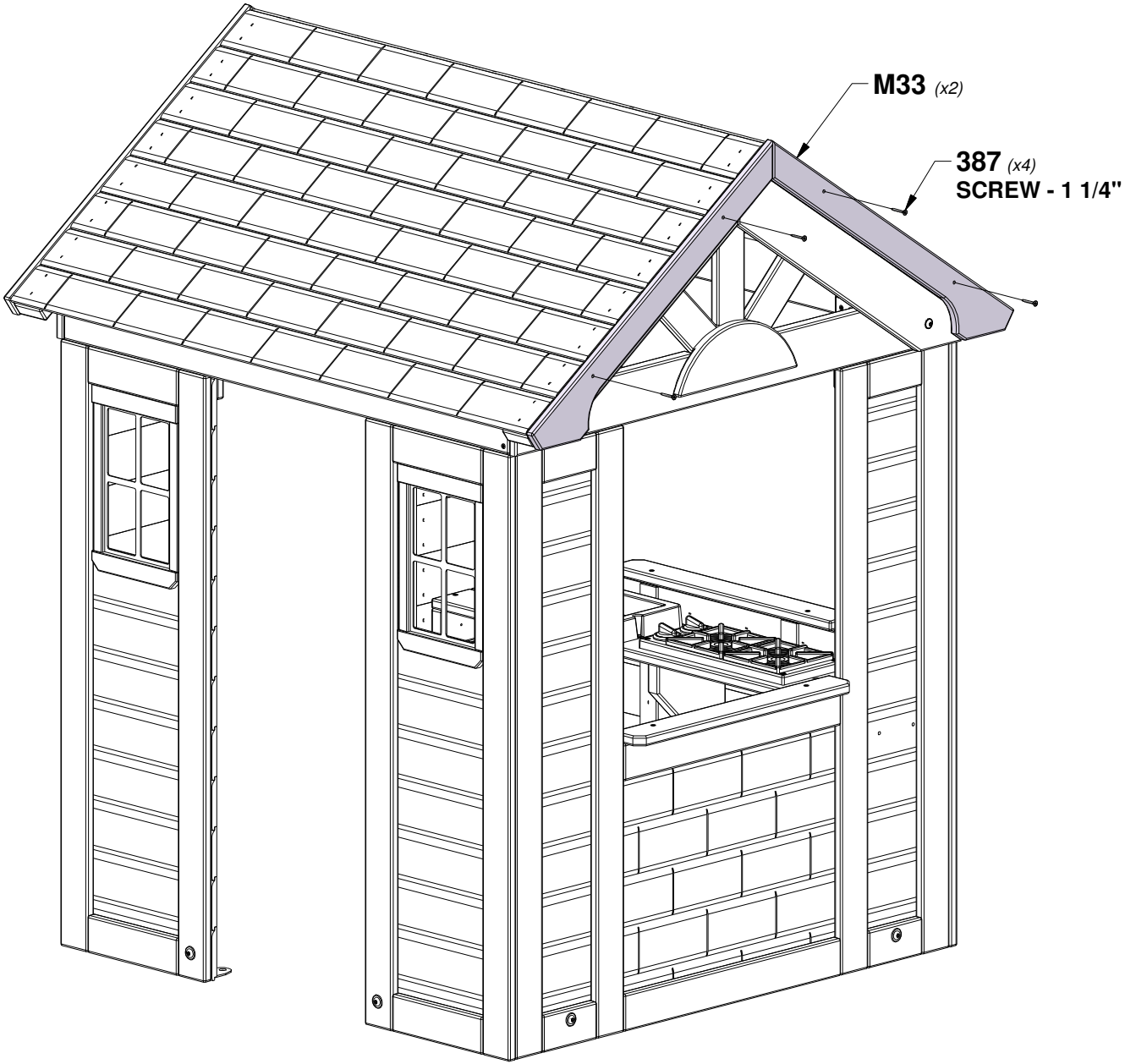

STEP 21 - PLAYHOUSE ASSEMBLY

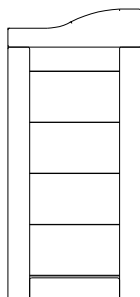

DP2 | LEFT DOOR ASSEMBLY - W2A01928
(x1) | 1 1/8"x8 3/8"x18 1/8" (27x211x460)

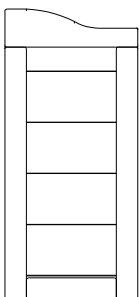

DP1 | RIGHT DOOR ASSEMBLY - W2A01927
(x1) | 1 1/8"x8 3/8"x18 1/8" (27x211x460)

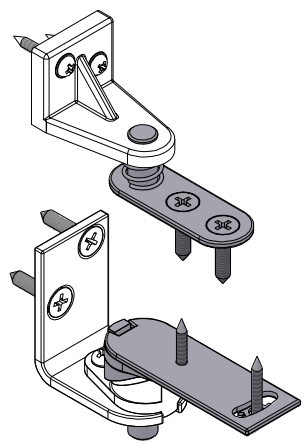

A4M00642 | SALOON DOOR HINGE KIT
(x2)

NOTE:
MAKE BOTH LEFT & RIGHT DOORS.

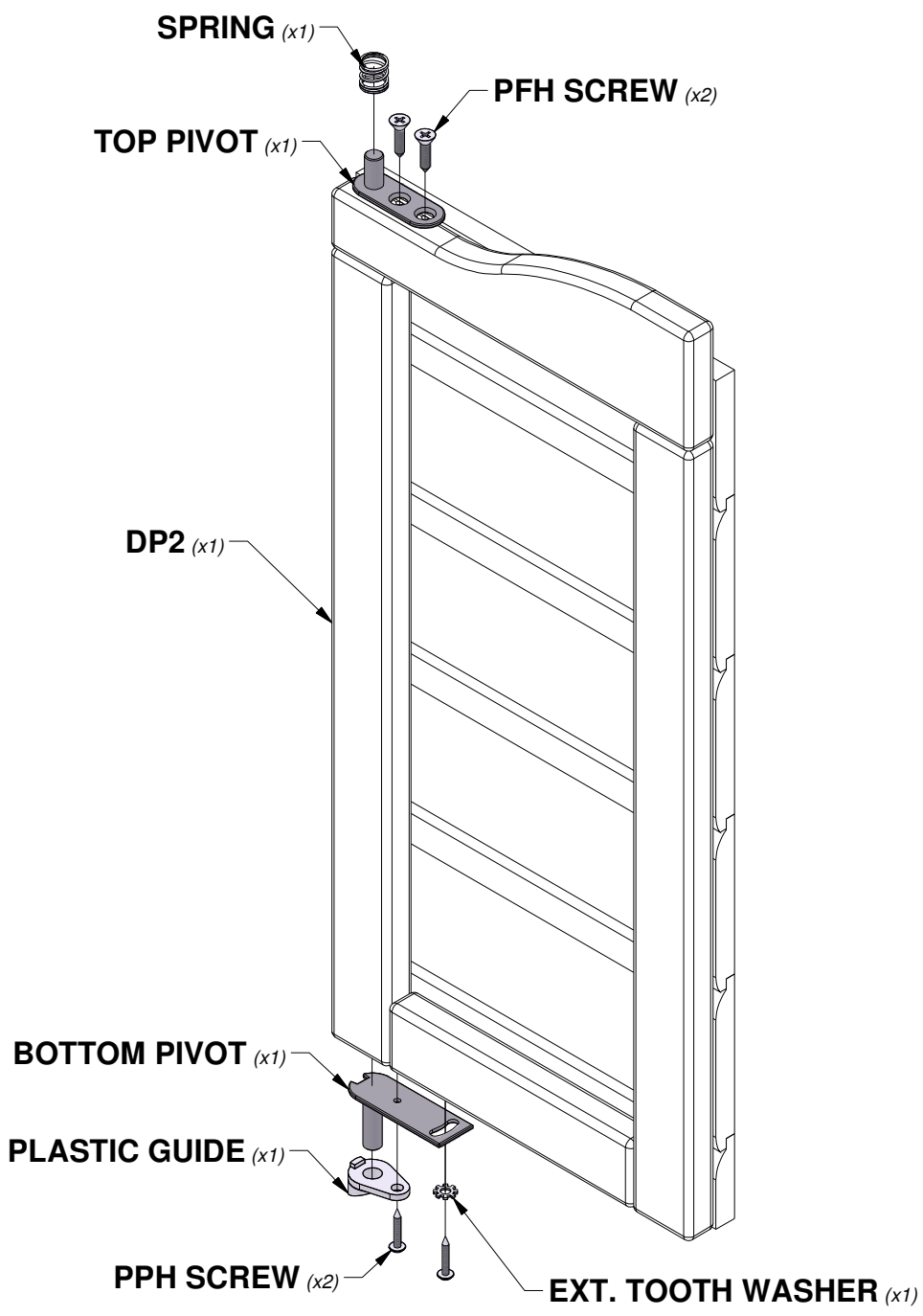

STEP 22 - PLAYHOUSE ASSEMBLY

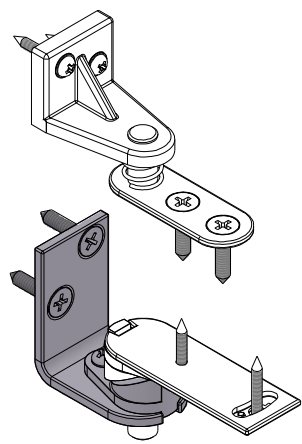

A4M00642 | SALOON DOOR HINGE KIT

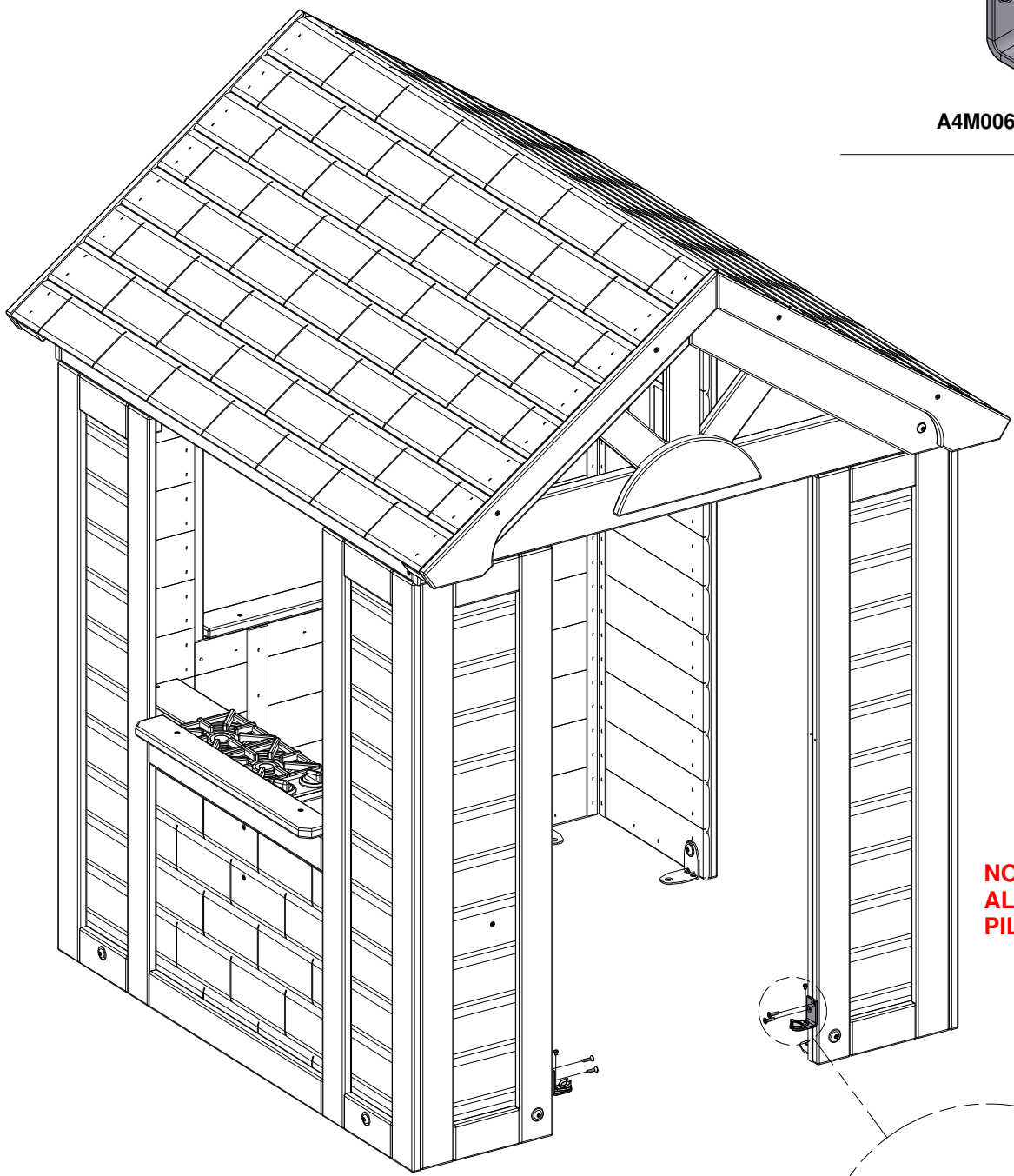

NOTE:
ALIGN HINGE BRACKETS USING
PILOT HOLES IN WALL PANELS.

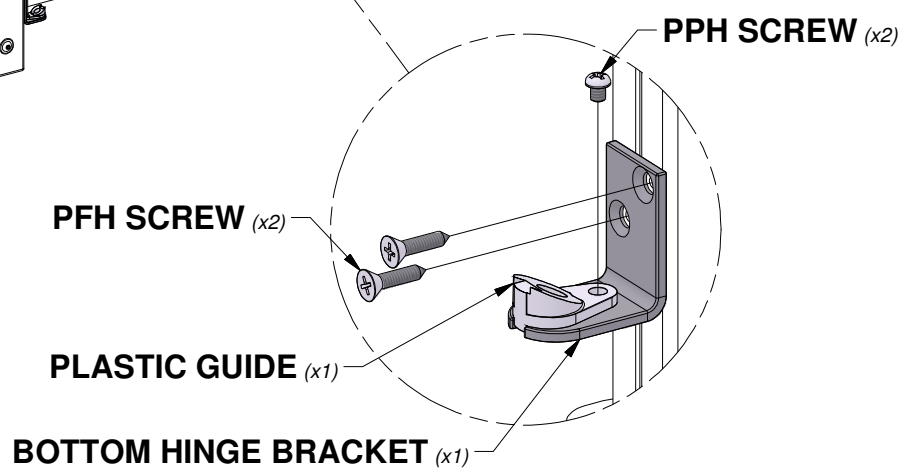

STEP 23 - PLAYHOUSE ASSEMBLY

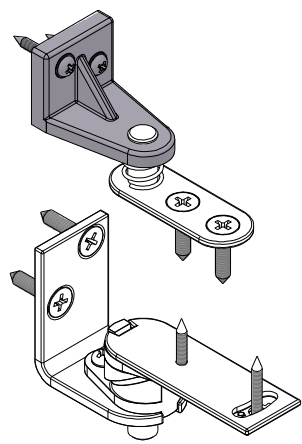

A4M00642 | SALOON DOOR HINGE KIT

NOTE:
PLACE THE TOP HINGE OVER
THE POST AND COMPRESS
THE SPRING UNTIL THE HOLES
IN THE TOP HINGE AND THE
HOLES IN THE PANEL ALIGN.
SECURE WITH PPH SCREWS,
AS SHOWN.

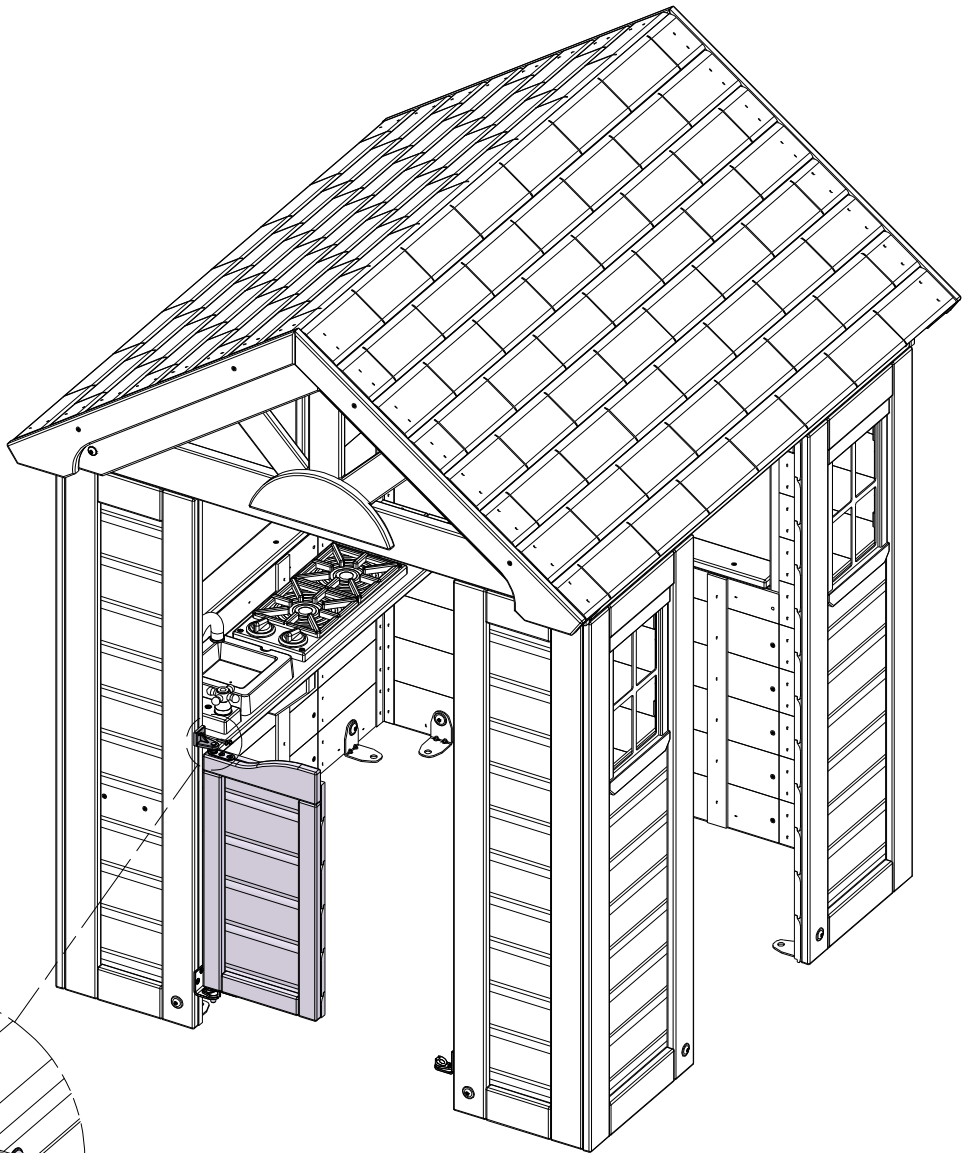

TOP HINGE (x1)

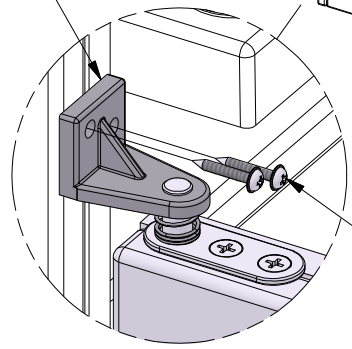

PPH SCREW (x2)

STEP 24 - PLAYHOUSE ASSEMBLY

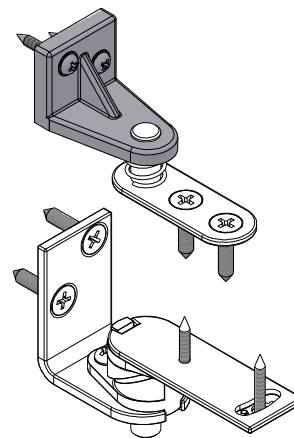

A4M00642 | SALOON DOOR HINGE KIT

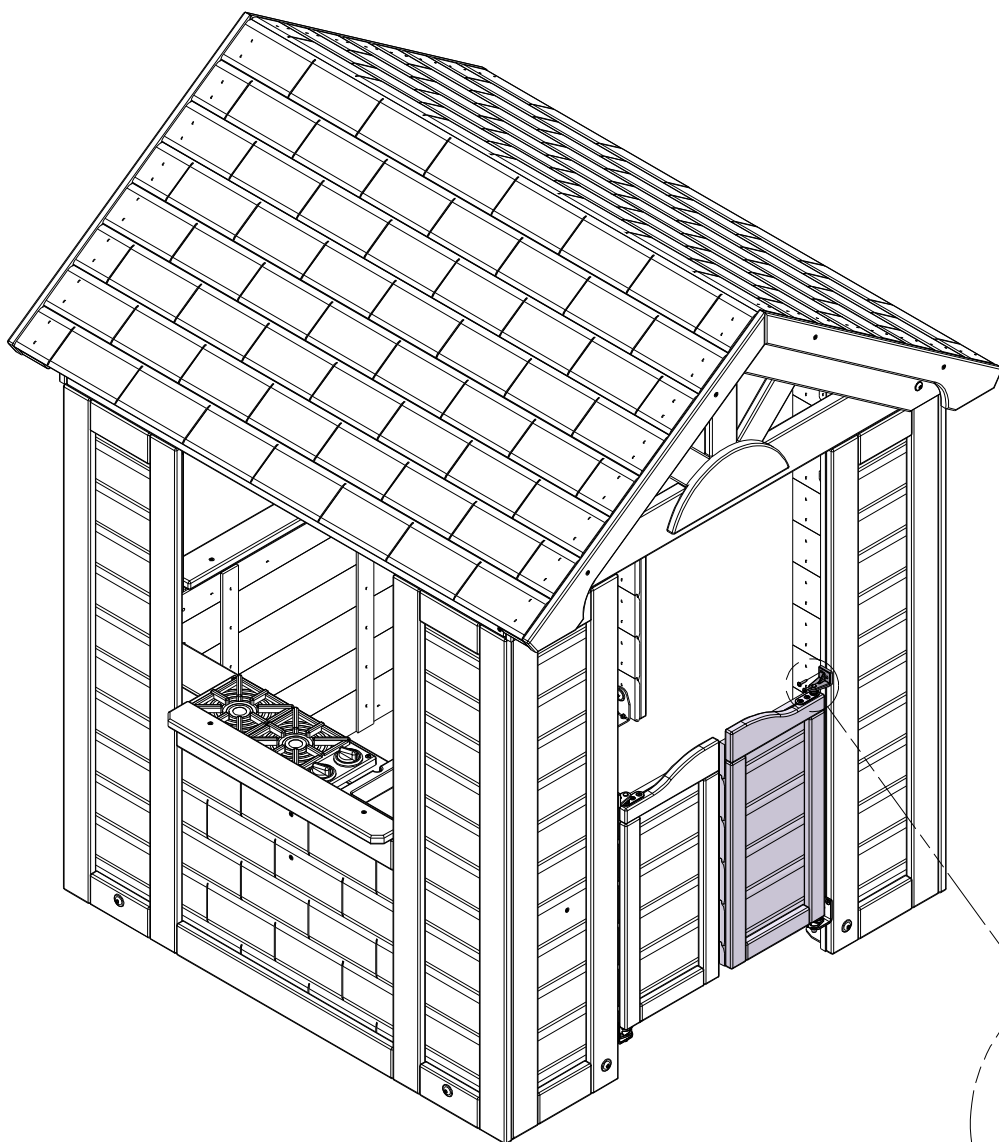

NOTE:
PLACE THE TOP HINGE OVER
THE POST AND COMPRESS
THE SPRING UNTIL THE HOLES
IN THE TOP HINGE AND THE
HOLES IN THE PANEL ALIGN.
SECURE WITH PPH SCREWS,
AS SHOWN.

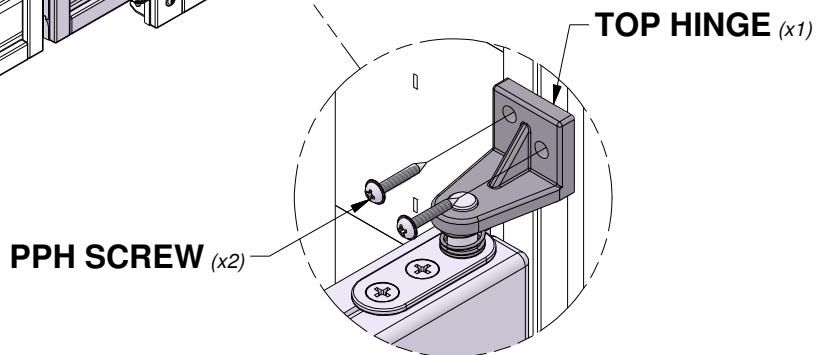

STEP 25 - PLAYHOUSE ASSEMBLY

QTY	PART NUMBER	DESCRIPTION
8	H100087	SCREW PFH 8x1-1/4"

S2 WINDOW TRIM - W4L16912
(x2) | 1"x1"x22" (24x24x558)

S3 WINDOW TRIM - W4L16913
(x2) | 1"x1"x23 1/8" (24x24x588)

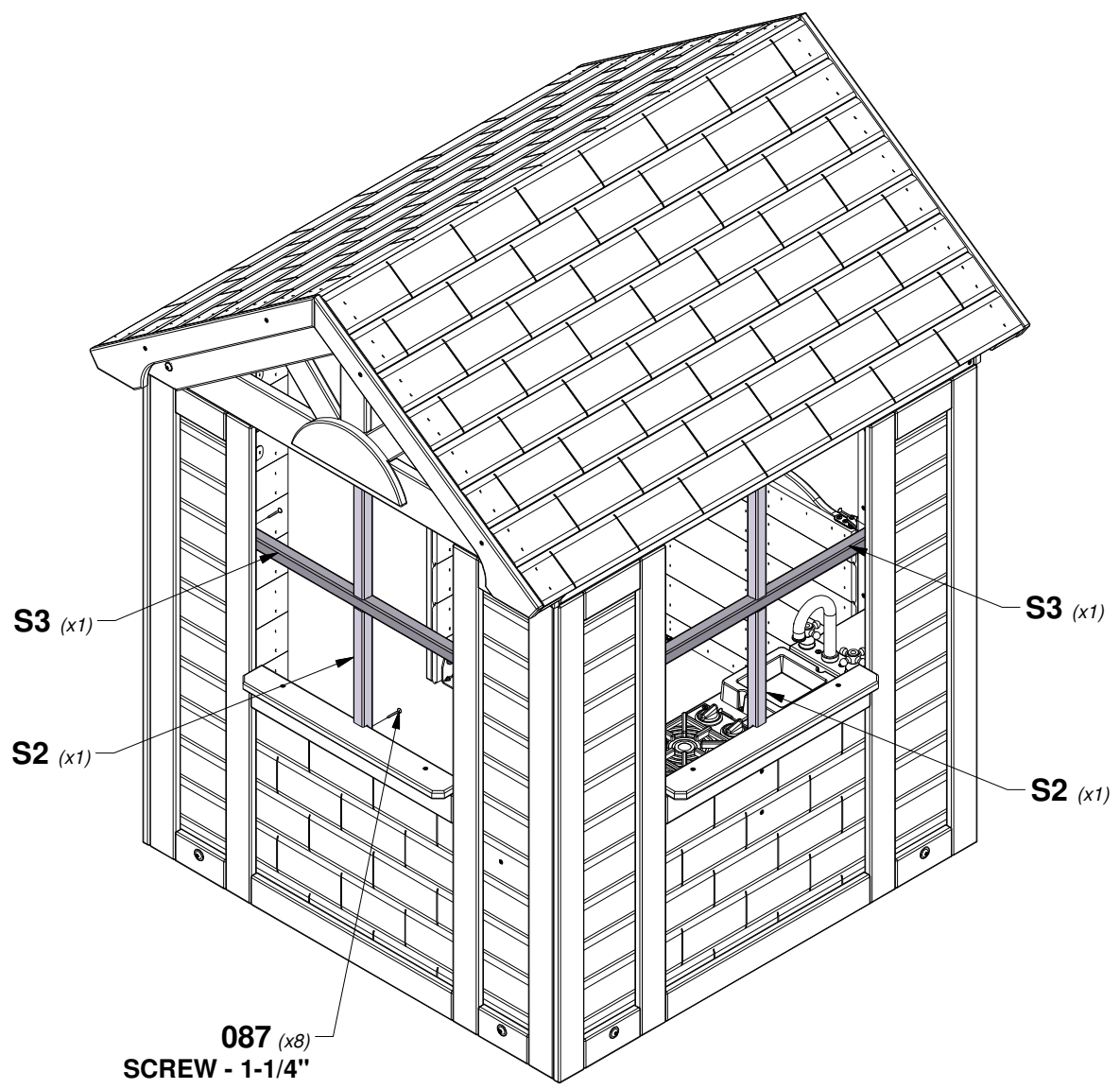
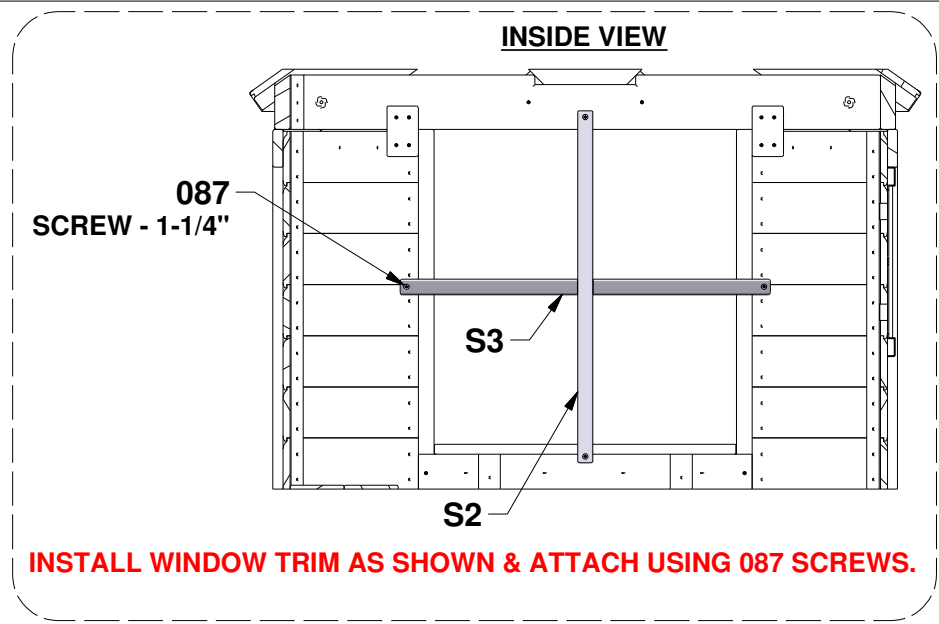

STEP 1 - FORT ASSEMBLY



E15 | FRONT RIGHT UPRIGHT - W2A03505
(x1) | 1 3/8"x3 3/8"x84" (36x86x2135)

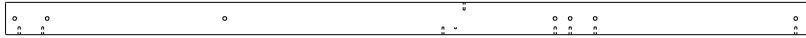

E8 | REAR RIGHT UPRIGHT - W4L16901
(x1) | 1 3/8"x3 3/8"x84" (36x86x2135)

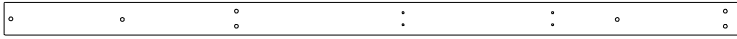

H7 | FLOOR RAIL - W4L06436
(x1) | 1"x3 3/8"x76 7/8" (24x86x1952)

QTY	PART NUMBER	DESCRIPTION
14	H100198	WASHER LOCK EXT 8x19 BLK
4	H100205	BOLT WH 5/16x2-1/4 BLK
14	H100379	T-NUT 5/16 BLK
6	H100457	BOLT WH 5/16x2 BLK
4	H100468	BOLT WH 5/16x1 BLK



M21 | WALL RAIL - W4L06465
(x1) | 5/8"x3 3/8"x54 3/8" (16x86x1380)



G5 | GROUND BOARD - W4L16882
(x2) | 1"x5 1/4"x52 3/4" (24x134x1341)

TIP:
INSTALL T-NUTS IN WOOD FIRST

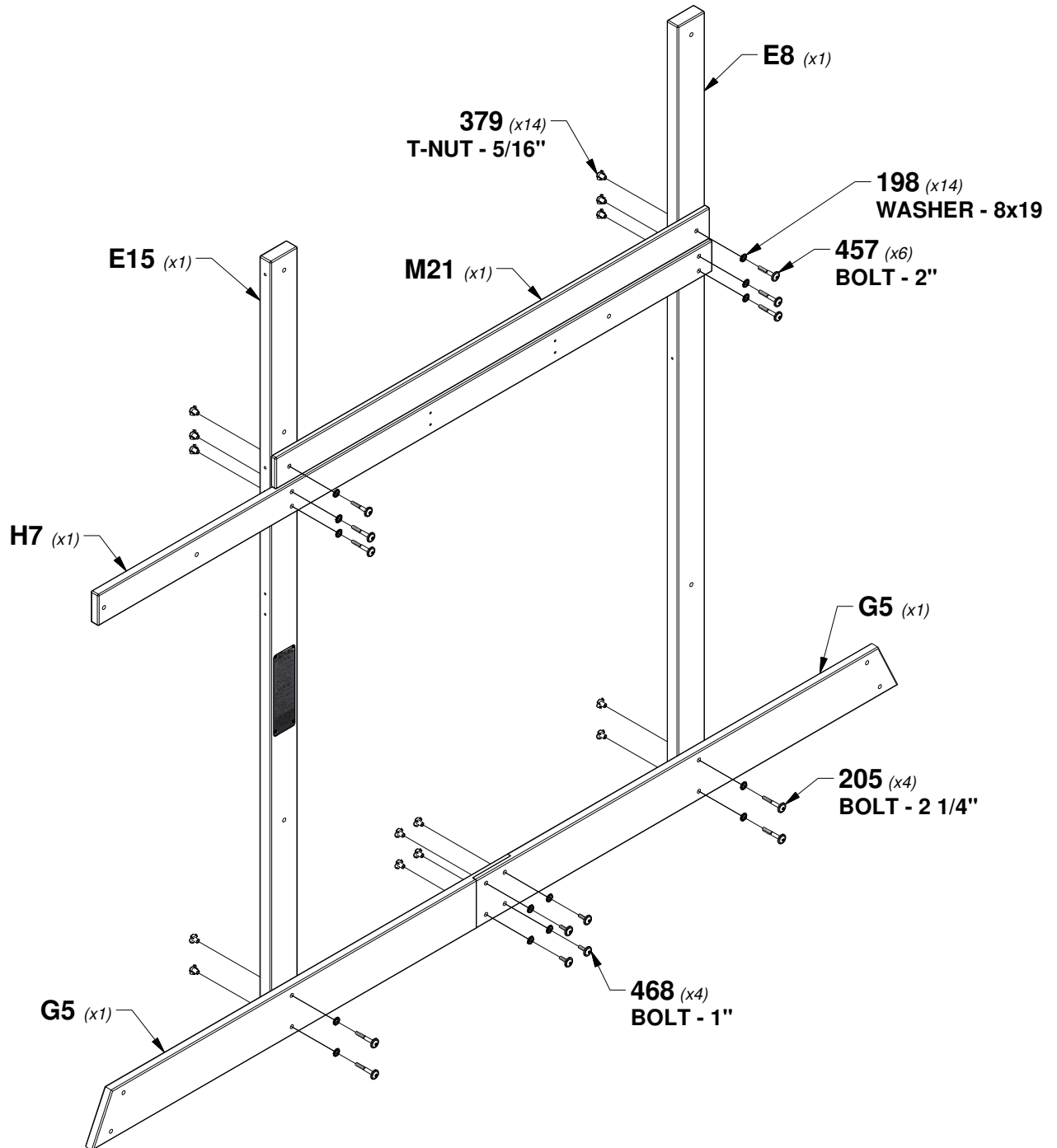

STEP 2 - FORT ASSEMBLY

QTY	PART NUMBER	DESCRIPTION
9	H100198	WASHER LOCK EXT 8x19 BLK
8	H100205	BOLT WH 5/16x2-1/4 BLK
9	H100379	T-NUT 5/16 BLK
1	H100457	BOLT WH 5/16x2 BLK



E7 | FRONT LEFT UPRIGHT - W4L16884
(x1) | 1 3/8"x3 3/8"x84" (36x86x2135)



E9 | FRONT RIGHT UPRIGHT - W4L16900
(x1) | 1 3/8"x3 3/8"x84" (36x86x2135)



H6 | FLOOR RAIL - W4L06435
(x1) | 1"x3 3/8"x76 7/8" (24x86x1952)



M23 | WALL RAIL - W4L06467
(x1) | 5/8"x3 3/8"x3 3/8" (16x86x86)



G3 | GROUND BOARD - W4L16878
(x1) | 1"x5 1/4"x78 1/2" (24x134x1995)

TIP:
INSTALL T-NUTS IN WOOD FIRST

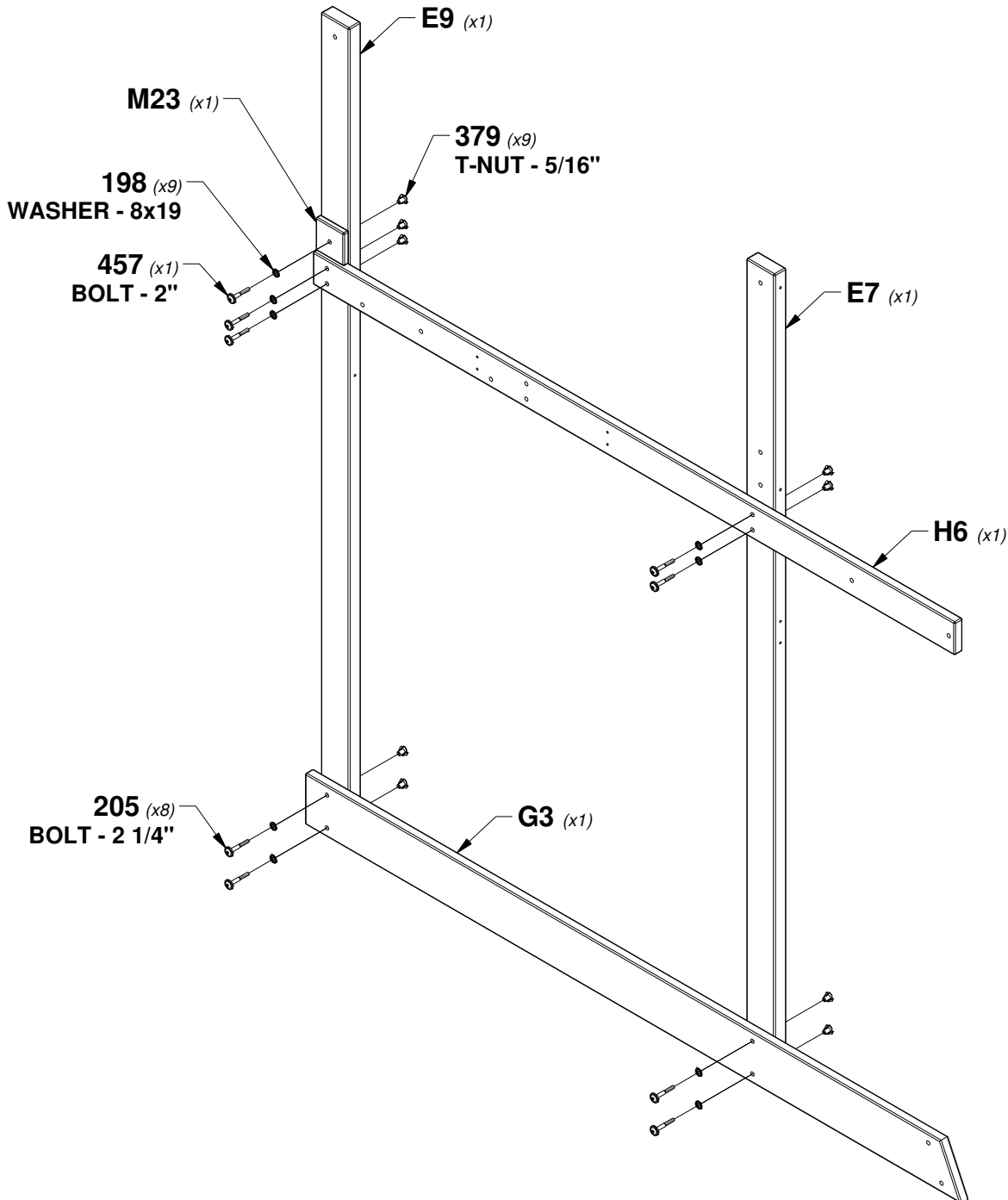

STEP 3 - FORT ASSEMBLY

QTY	PART NUMBER	DESCRIPTION
8	H100197	LAG SCREW WH 5/16x2-1/2 BLK
8	H100198	WASHER LOCK EXT 8x19 BLK



G6 | GROUND BOARD - W4L16883
(x2) | 1"x5 1/4"x52 1/2" (24x134x1335)

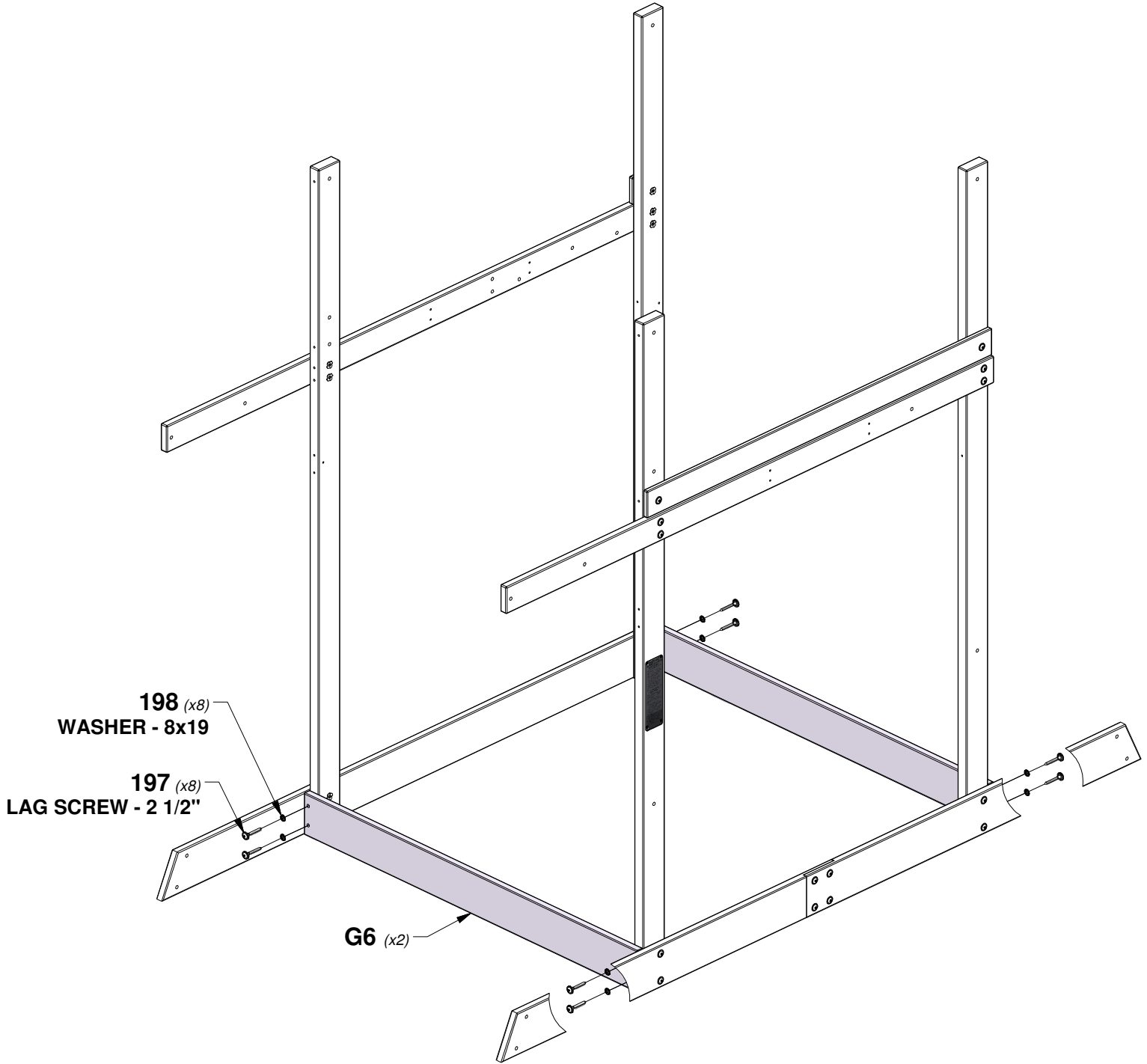

STEP 4 - FORT ASSEMBLY

QTY	PART NUMBER	DESCRIPTION
8	H100198	WASHER LOCK EXT 8x19 BLK
2	H100379	T-NUT 5/16 BLK
8	H100458	LAG SCREW WH 5/16x2 BLK

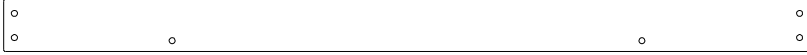

H8 | FLOOR RAIL - W4L06437
(x1) | 1"x3 3/8"x52 1/2" (24x86x1335)



H10 | FLOOR RAIL - W4L06439
(x1) | 1"x3 3/8"x54 1/2" (24x86x1383)

TIP:
INSTALL T-NUTS IN WOOD FIRST

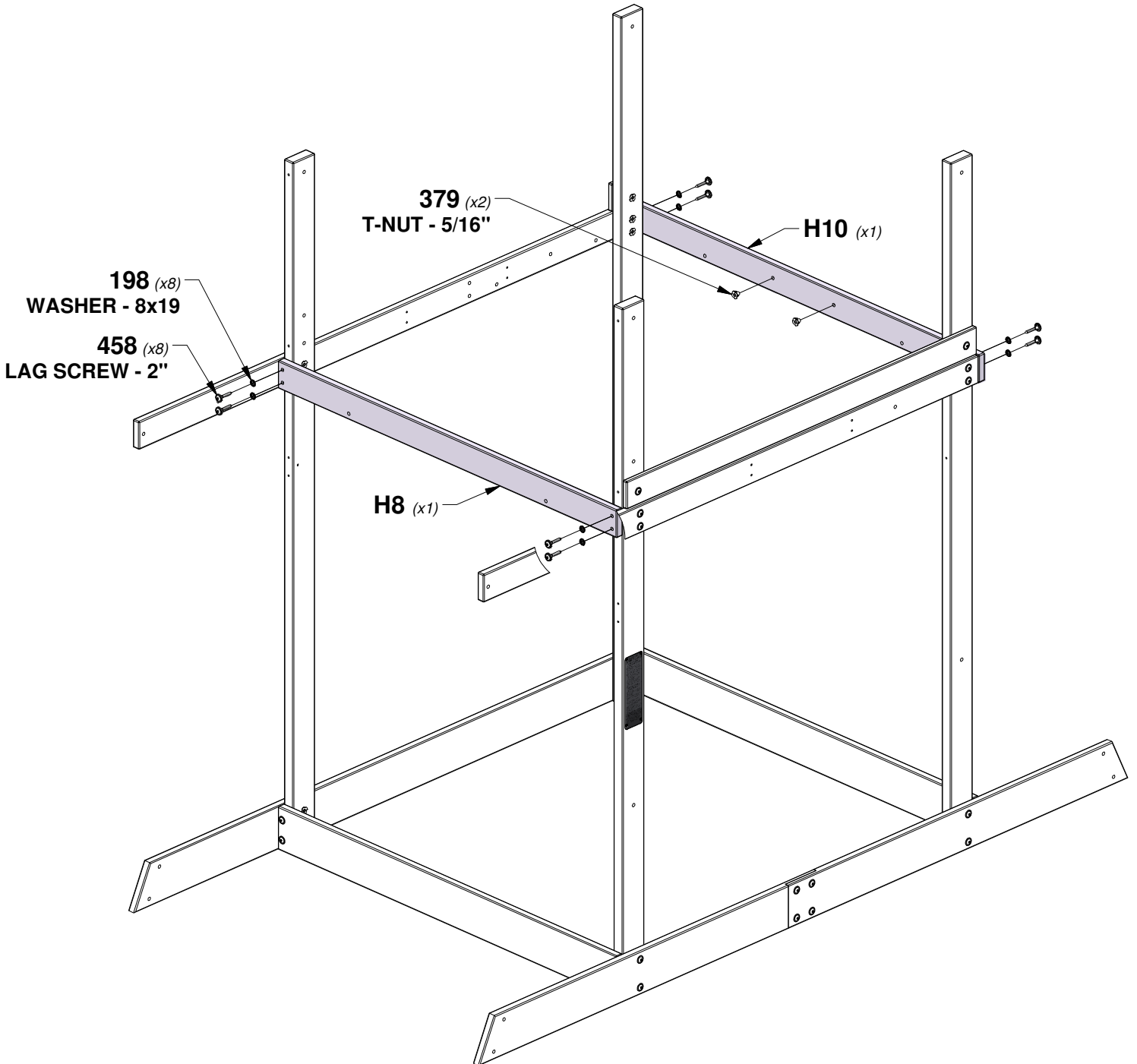

STEP 5 - FORT ASSEMBLY



E13 DECK BRACE - W4L16880
(x6) 1 3/8"x3 3/8"x16 7/8" (36x86x428)

QTY	PART NUMBER	DESCRIPTION
6	H100198	WASHER LOCK EXT 8x19 BLK
6	H100205	BOLT WH 5/16x2-1/4 BLK
6	H100378	BOLT WH 5/16x1 3/4 BLK
6	H100403	LAG SCREW WH 1/4x1-1/2 BLK
6	H100405	WASHER LOCK EXT 6x15 BLK

TIP:
INSTALL T-NUTS IN WOOD FIRST

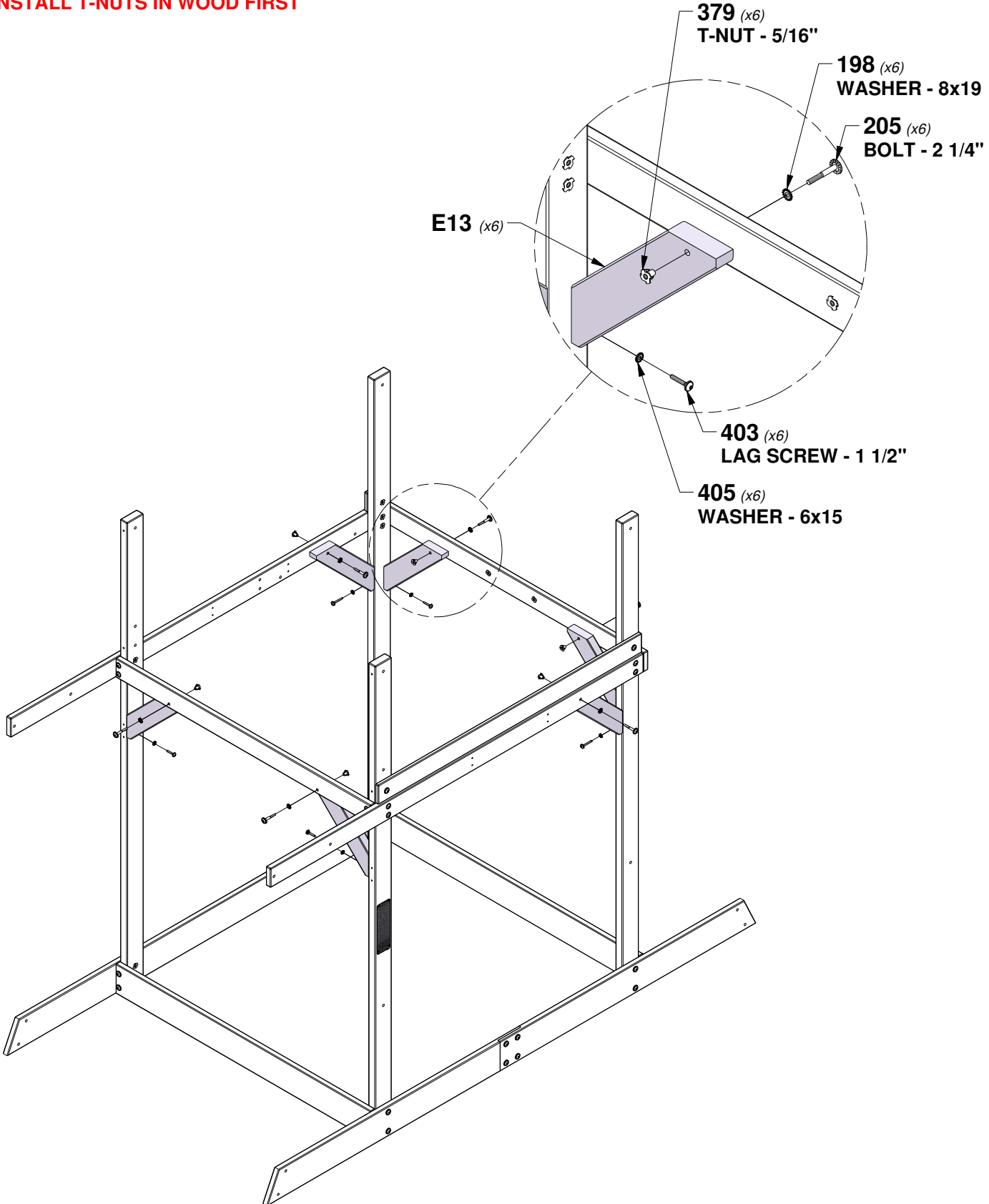

STEP 6 - FORT ASSEMBLY

QTY	PART NUMBER	DESCRIPTION
2	H100198	WASHER LOCK EXT 8x19 BLK
2	H100458	LAG SCREW WH 5/16x2 BLK



F1 | **RIGHT DECK UPRIGHT - W4L06440**
 (x1) | 1 3/8"x2 3/8"x30 3/8" (36x60x770)



F3 | **LEFT DECK UPRIGHT - W4L06445**
 (x1) | 1 3/8"x2 3/8"x30 3/8" (36x60x770)

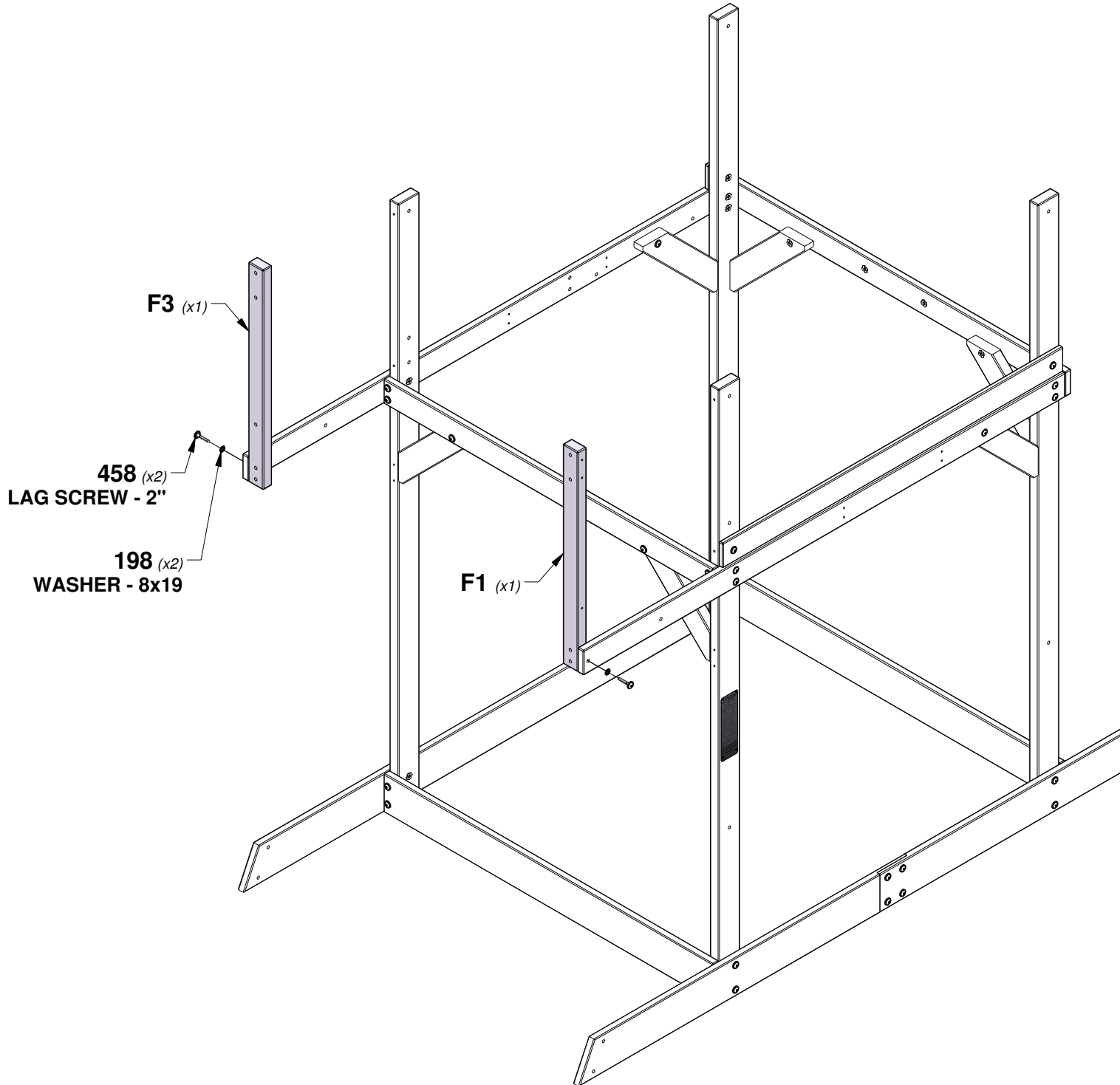

STEP 7 - FORT ASSEMBLY

QTY	PART NUMBER	DESCRIPTION
4	H100198	WASHER LOCK EXT 8x19 BLK
4	H100205	BOLT WH 5/16x2-1/4 BLK
4	H100379	T-NUT 5/16 BLK

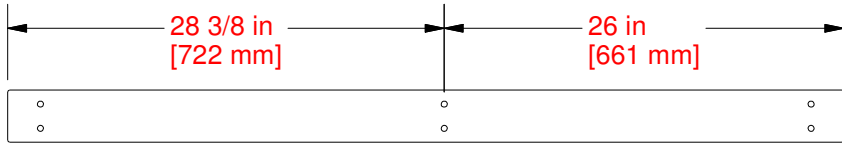

H9 | FLOOR RAIL - W4L16592
 (x1) | 1"x3 3/8"x54 1/2" (24x86x1383)

TIP:
INSTALL T-NUTS IN WOOD FIRST

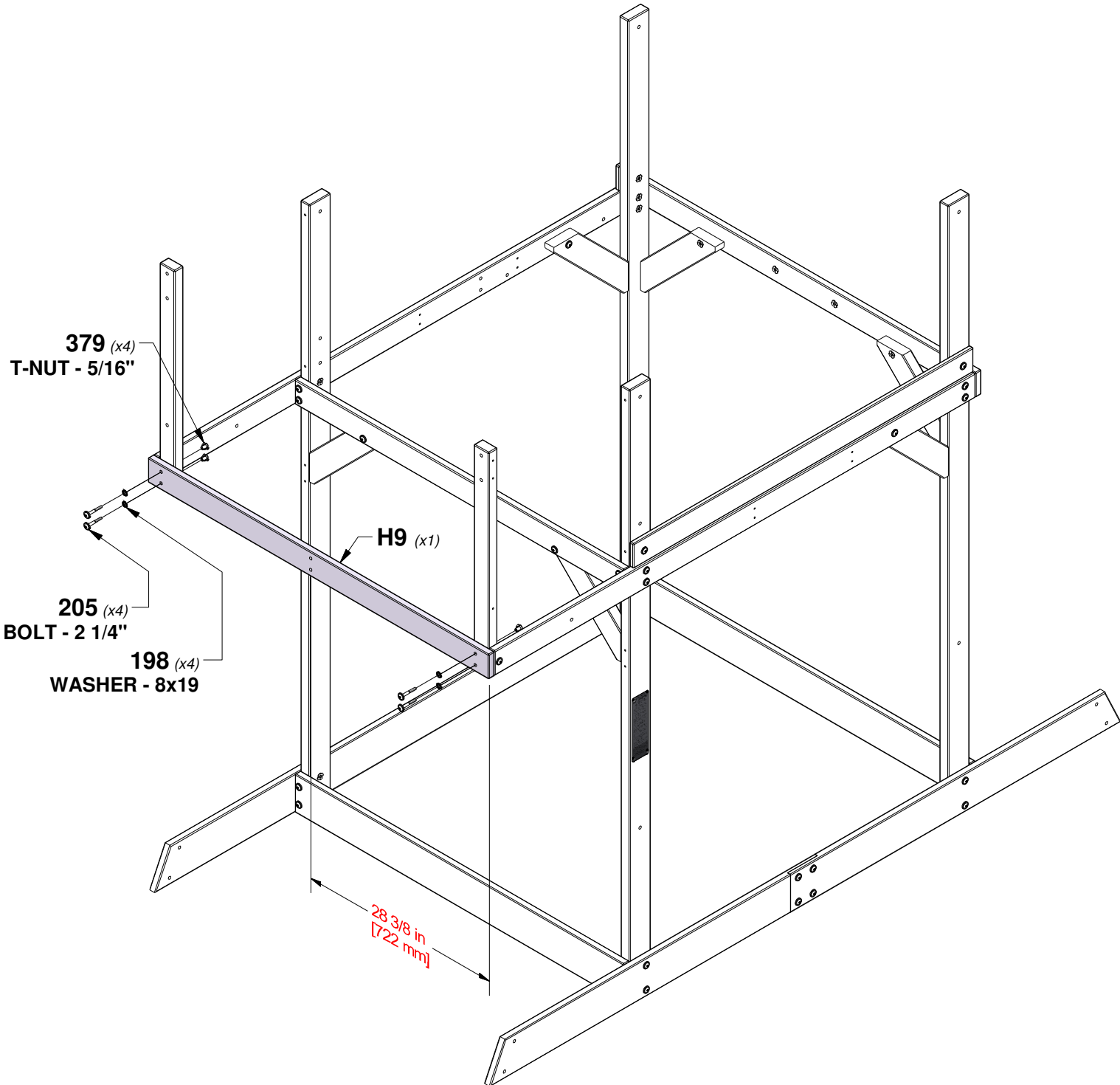

STEP 8 - FORT ASSEMBLY

QTY	PART NUMBER	DESCRIPTION
2	H100198	WASHER LOCK EXT 8x19 BLK
2	H100205	BOLT WH 5/16x2-1/4 BLK
2	H100379	T-NUT 5/16 BLK



F2 | DECK UPRIGHT - W4L06441
 (x1) | 1 3/8"x2 3/8"x30 3/8" (36x60x770)

TIP:
 INSTALL T-NUTS IN WOOD FIRST

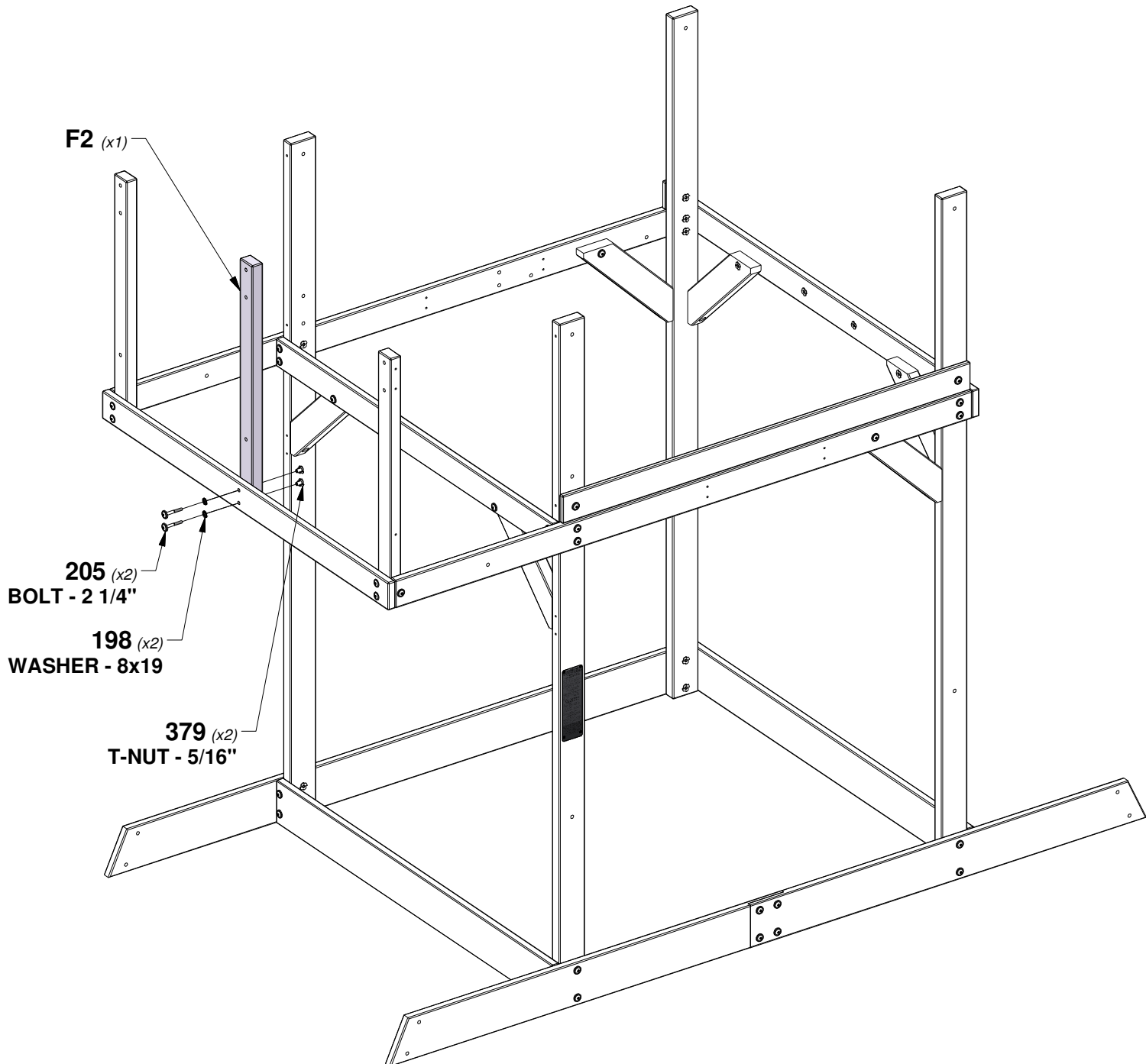

STEP 9 - FORT ASSEMBLY

QTY	PART NUMBER	DESCRIPTION
21	H100089	SCREW PFH 8x1-3/4"

T1 | SUPPORT BOARD - W4L16586
 (x1) | 1"x1 3/8"x21 1/2" (24x34x545)

T2 | SUPPORT BOARD - W4L16587
 (x1) | 1"x1 3/8"x23 7/8" (24x34x606)

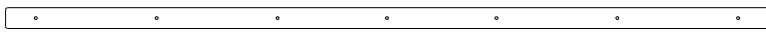

T4 | SUPPORT BOARD - W4L16588
 (x1) | 1"x1 3/8"x49 5/8" (24x34x1262)



J9 | SUPPORT BOARD - W4L06064
 (x3) | 1"x2 3/8"x3" (24x60x76)

NOTE:
 HOLD ALL SUPPORT BOARDS DOWN 5/8 in [17 mm]

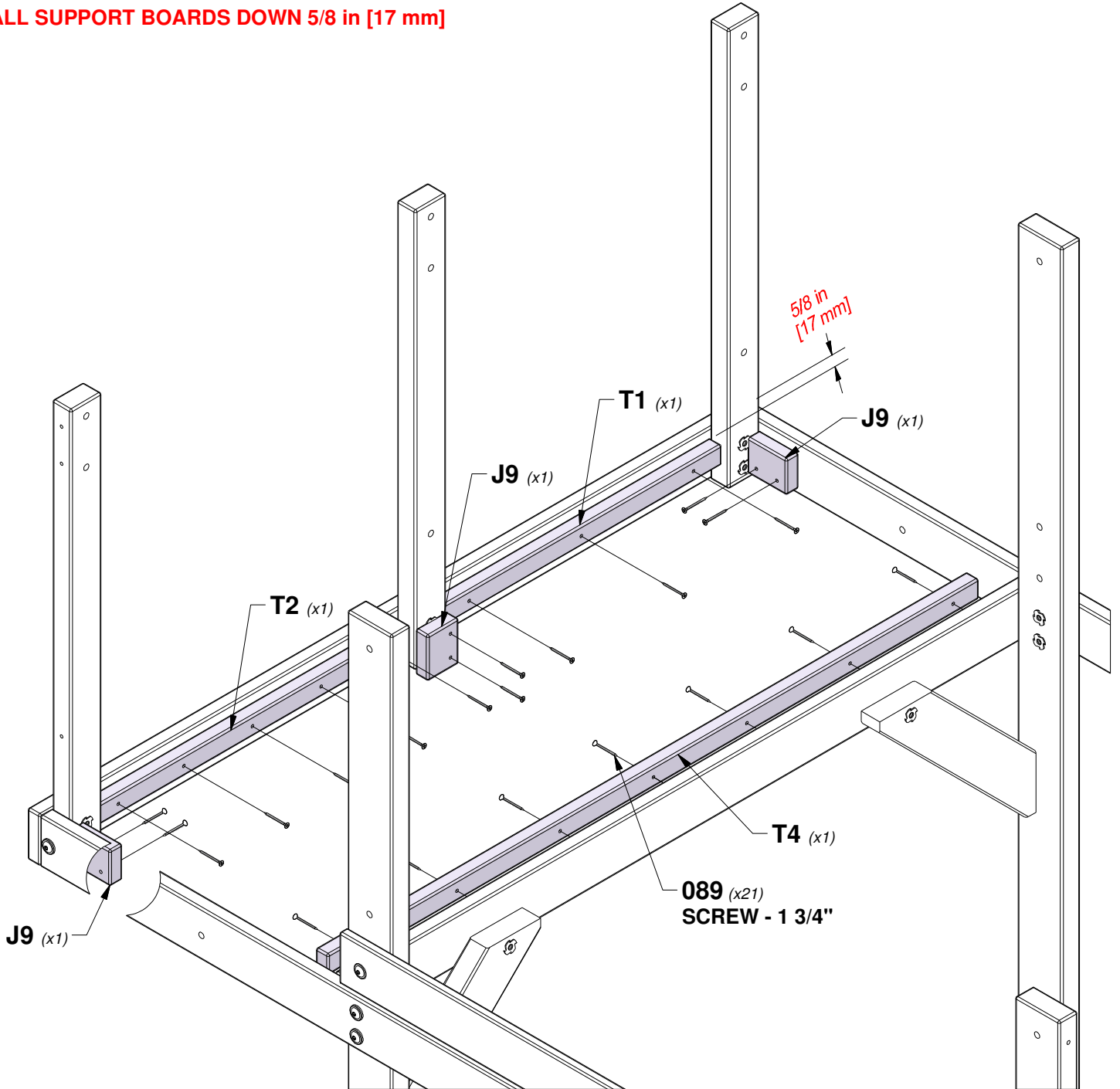

STEP 10 - FORT ASSEMBLY

QTY	PART NUMBER	DESCRIPTION
8	H100111	SCREW PFH 8x2

J4 FLOOR SUPPORT - W4L06454
(x2) 1"x2 3/8"x52 1/2" (24x60x1335)

NOTE:
HOLD ALL SUPPORT BOARDS DOWN 5/8 in [17 mm]

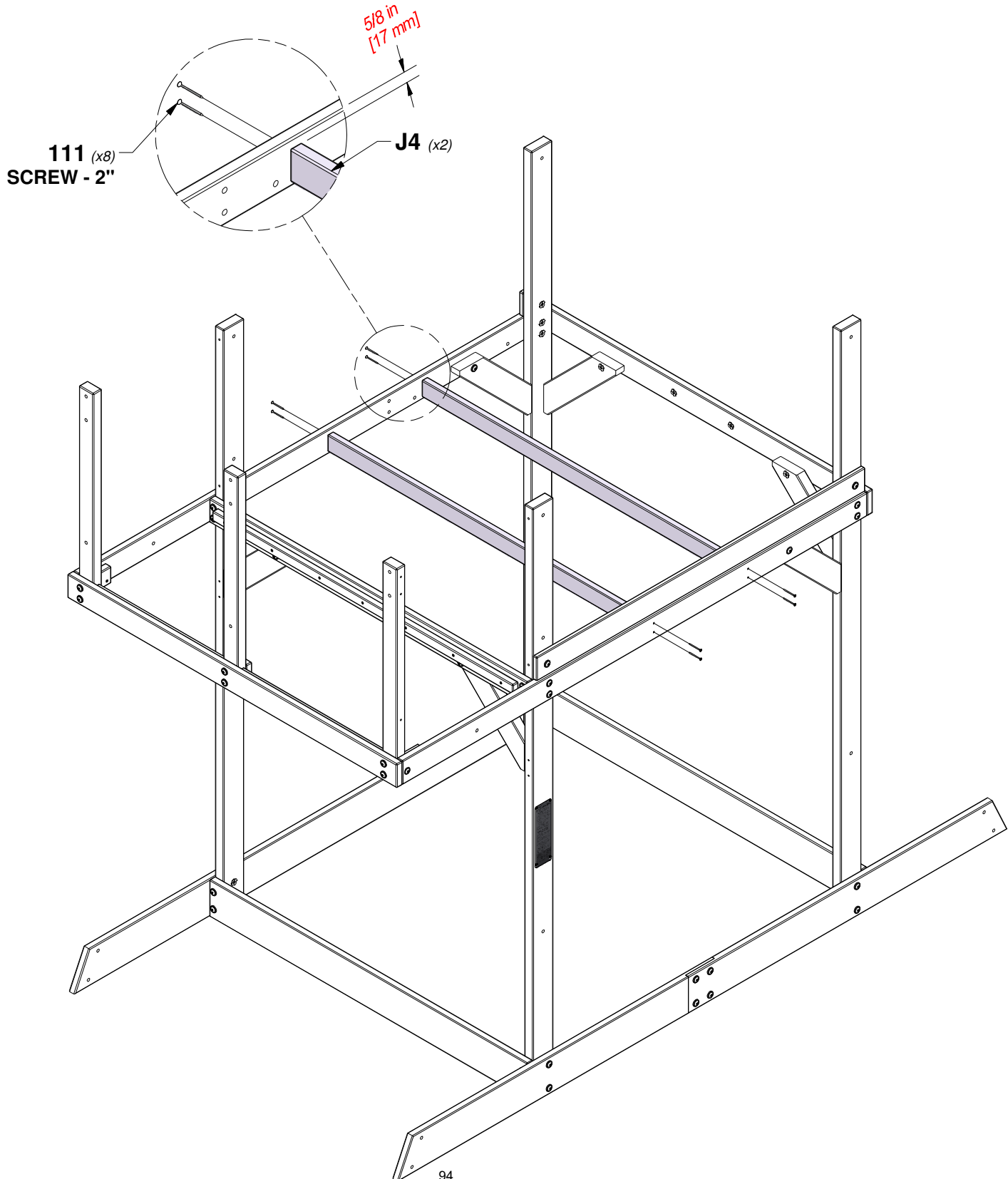

STEP 11 - FORT ASSEMBLY

QTY	PART NUMBER	DESCRIPTION
8	H100089	SCREW PFH 8x1-3/4"

T3 SUPPORT BOARD - W4L06444
(x2) 1"x1 3/8"x49 5/8" (24x34x1262)

NOTE:
HOLD ALL SUPPORT BOARDS DOWN 5/8 in [17 mm]

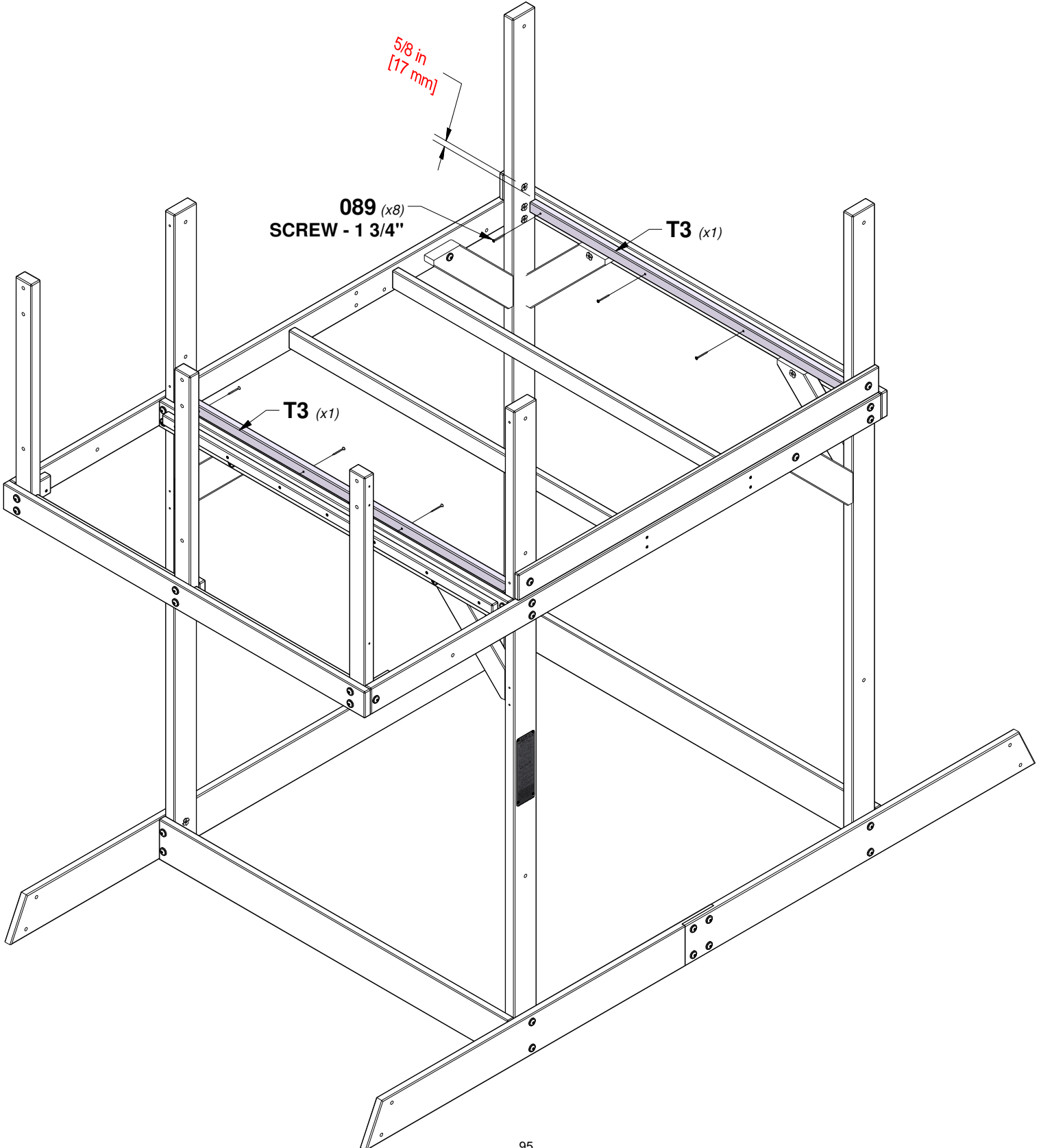

STEP 12 - FORT ASSEMBLY

QTY	PART NUMBER	DESCRIPTION
2	H100198	WASHER LOCK EXT 8x19 BLK
2	H100205	BOLT WH 5/16x2-1/4 BLK
2	H100379	T-NUT 5/16 BLK



E10 | FORT UPRIGHT - W4L16899
(x1) | 1 3/8"x3 3/8"x51 3/8" (36x86x1305)

TIP:
INSTALL T-NUTS IN WOOD FIRST

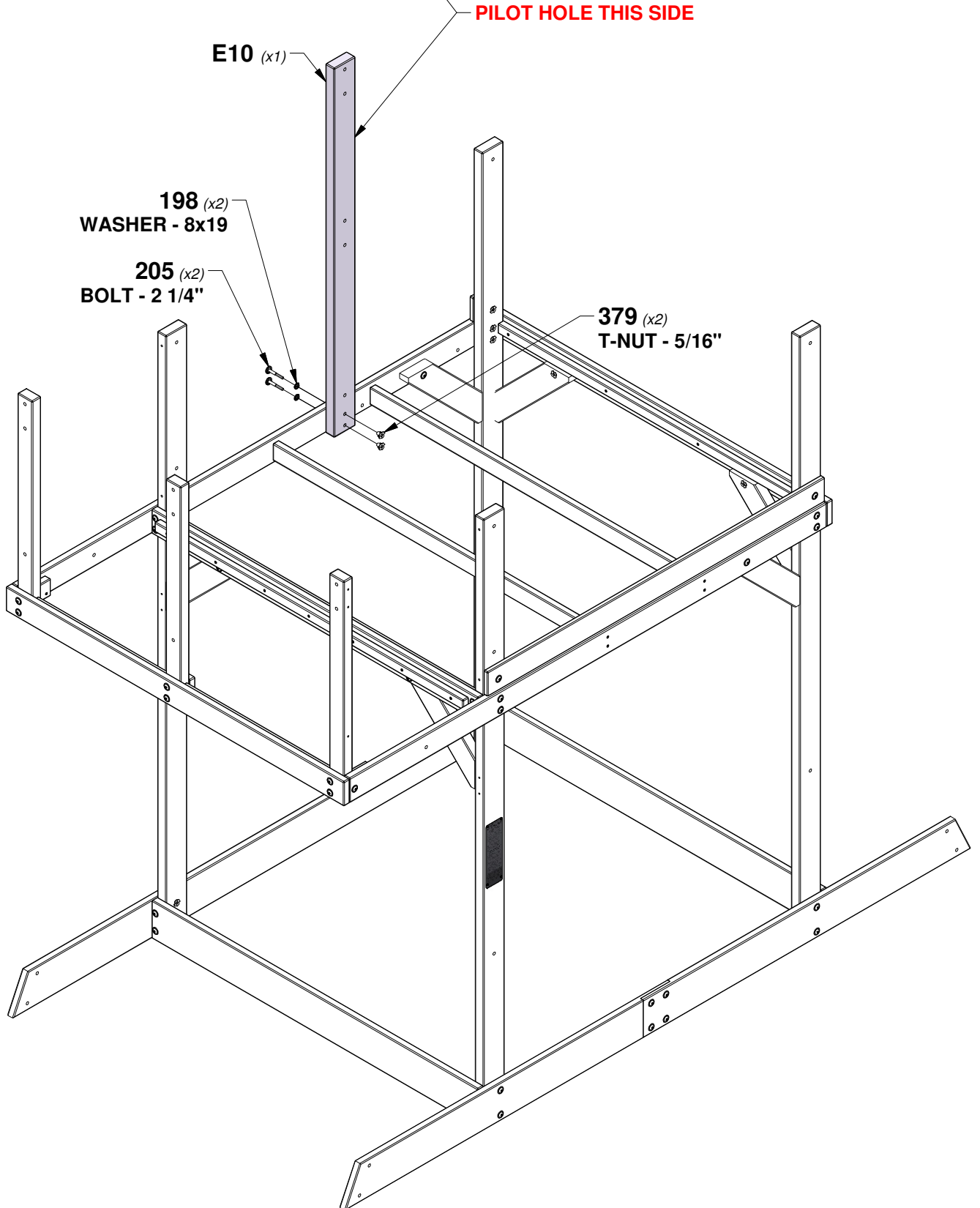

STEP 13 - FORT ASSEMBLY

QTY	PART NUMBER	DESCRIPTION
6	H100086	SCREW PFH 8x1-1/2"



M11 | FRONT CORNER BOARD - W4L16903
(x2) | 5/8"x3 3/8"x51" (16x86x1297)

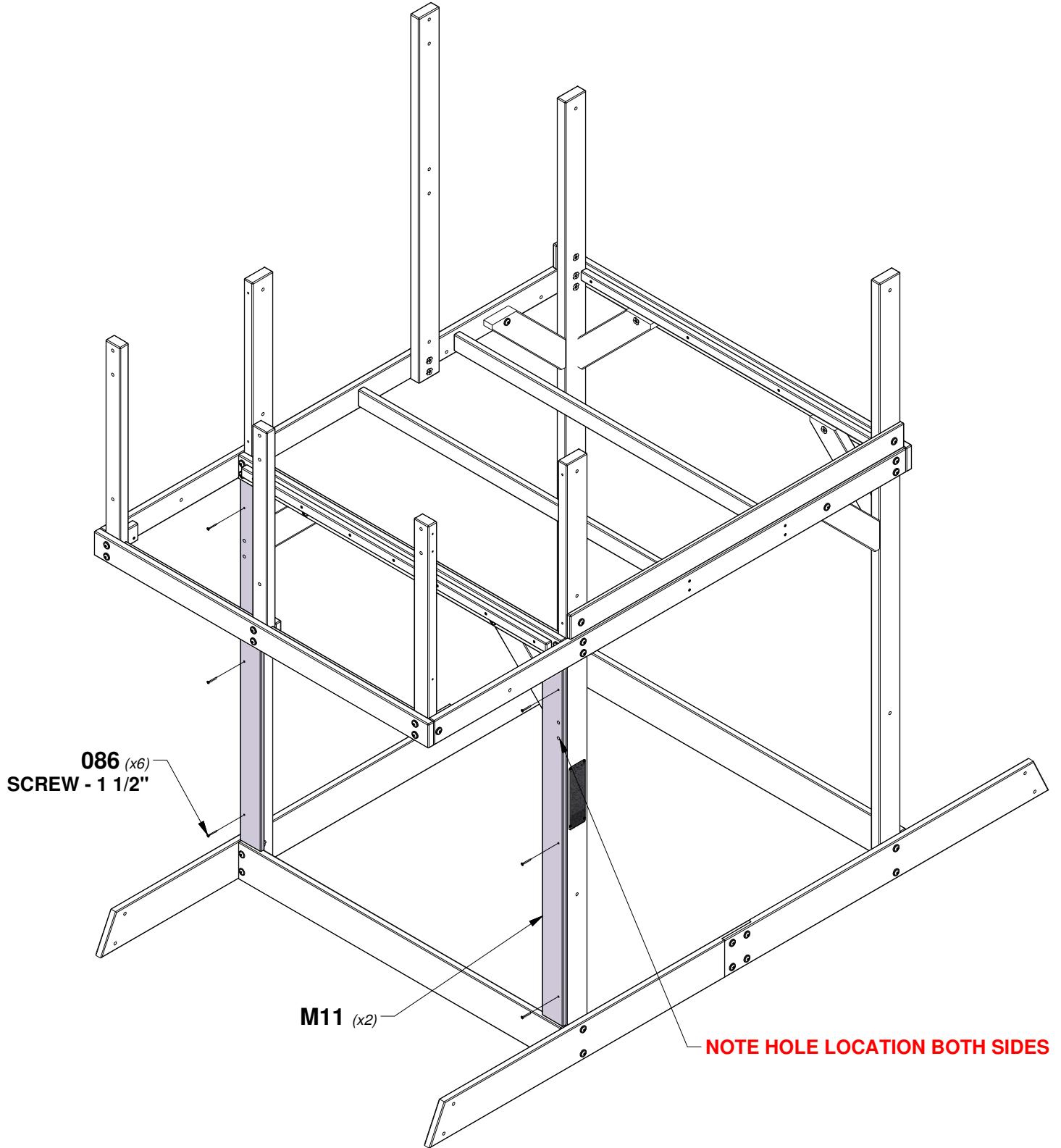

STEP 14 - FORT ASSEMBLY



E13 | DECK BRACE - W4L16880
 (x2) | 1 3/8"x3 3/8"x16 7/8" (36x86x428)

QTY	PART NUMBER	DESCRIPTION
2	H100198	WASHER LOCK EXT 8x19 BLK
2	H100205	BOLT WH 5/16x2-1/4 BLK
2	H100379	T-NUT 5/16 BLK
2	H100405	WASHER LOCK EXT 6x15 BLK
2	H100456	LAG SCREW WH 1/4x2-1/2 BLK

TIP:
INSTALL T-NUTS IN WOOD FIRST

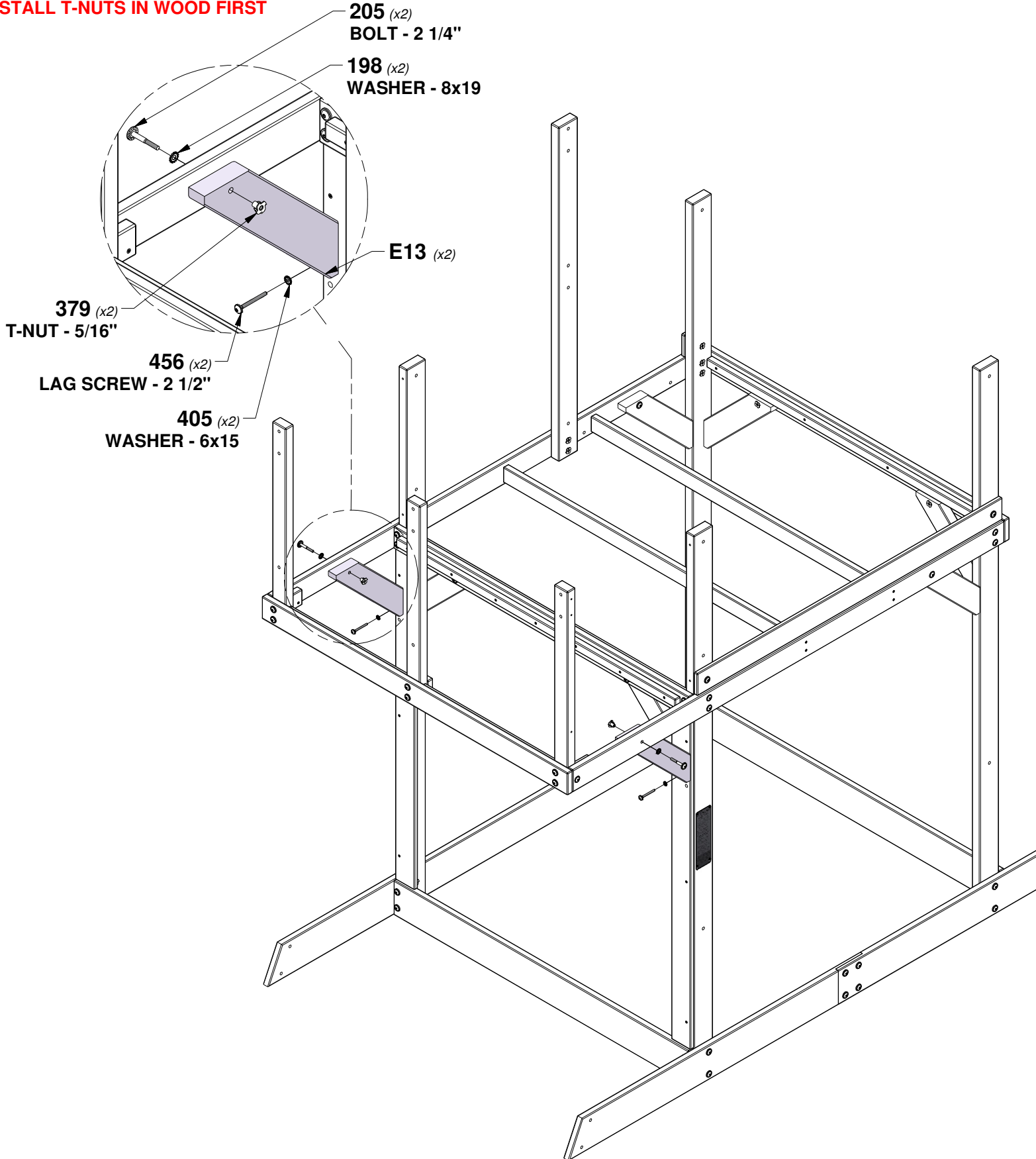

STEP 15 - FORT ASSEMBLY

QTY	PART NUMBER	DESCRIPTION
6	H100086	SCREW PFH 8x1-1/2"

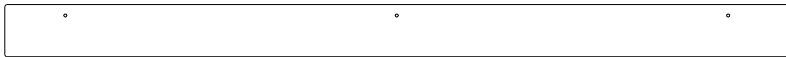

M12 REAR CORNER BOARD - W4L16914
(x1) 5/8"x3 3/8"x51" (16x86x1297)



M13 REAR CORNER BOARD - W4L16904
(x1) 5/8"x3 3/8"x51" (16x86x1297)

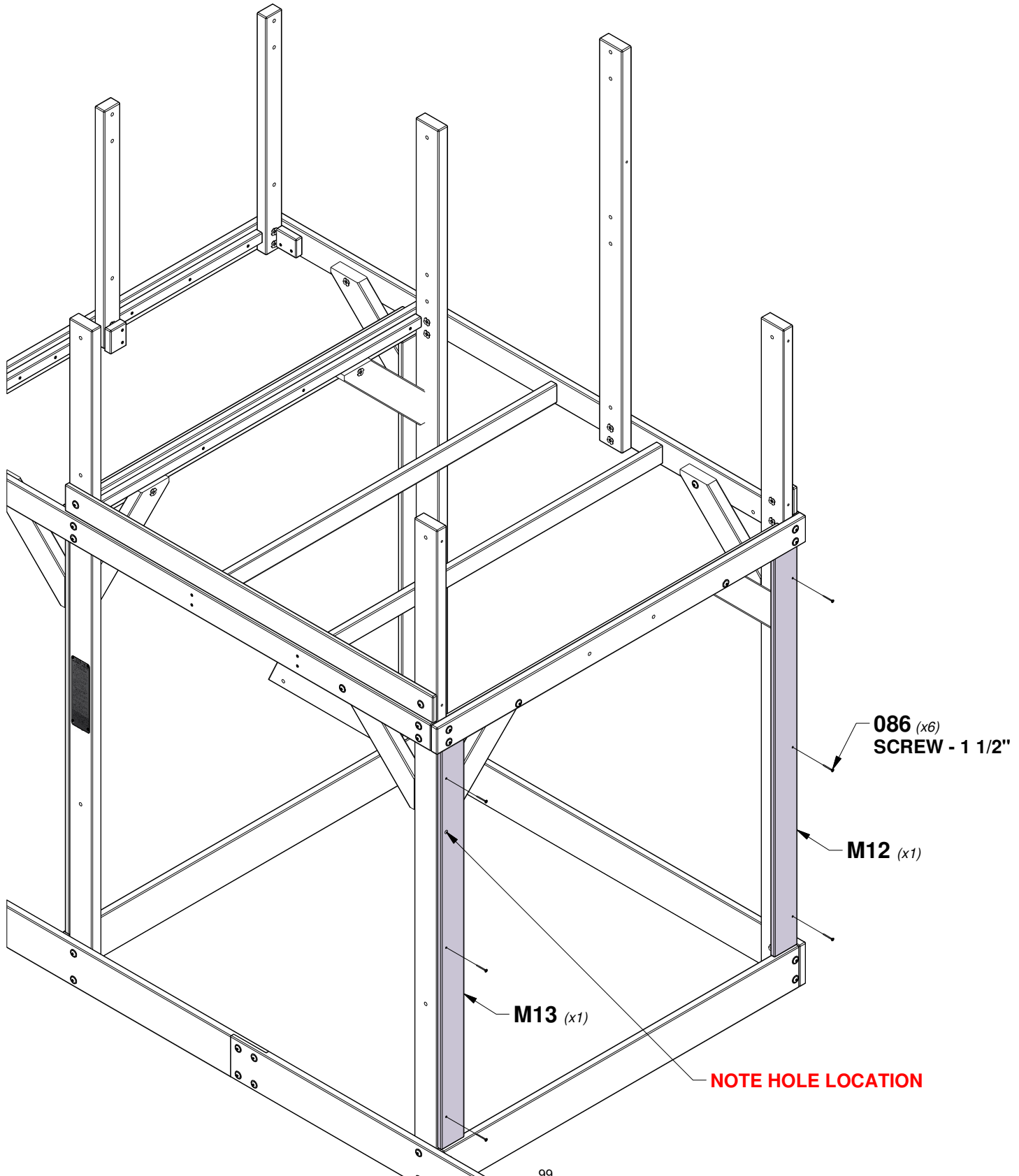

STEP 16 - FORT ASSEMBLY

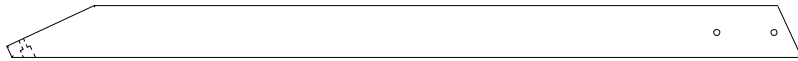

E14 | ANGLE BRACE - W4L16881
(x3) | 1 3/8"x3 3/8"x51 3/4" (36x86x1315)



M38 | SAFETY BOARD - W4L07011
(x1) | 5/8"x3 3/8"x54 3/8" (16x86x1380)

QTY	PART NUMBER	DESCRIPTION
8	H100198	WASHER LOCK EXT 8x19 BLK
6	H100205	BOLT WH 5/16x2-1/4 BLK
8	H100379	T-NUT 5/16 BLK
3	H100405	WASHER LOCK EXT 6x15 BLK
3	H100456	LAG SCREW WH 1/4x2-1/2 BLK
2	H100457	BOLT WH 5/16x2 BLK

TIP:
INSTALL T-NUTS IN WOOD FIRST

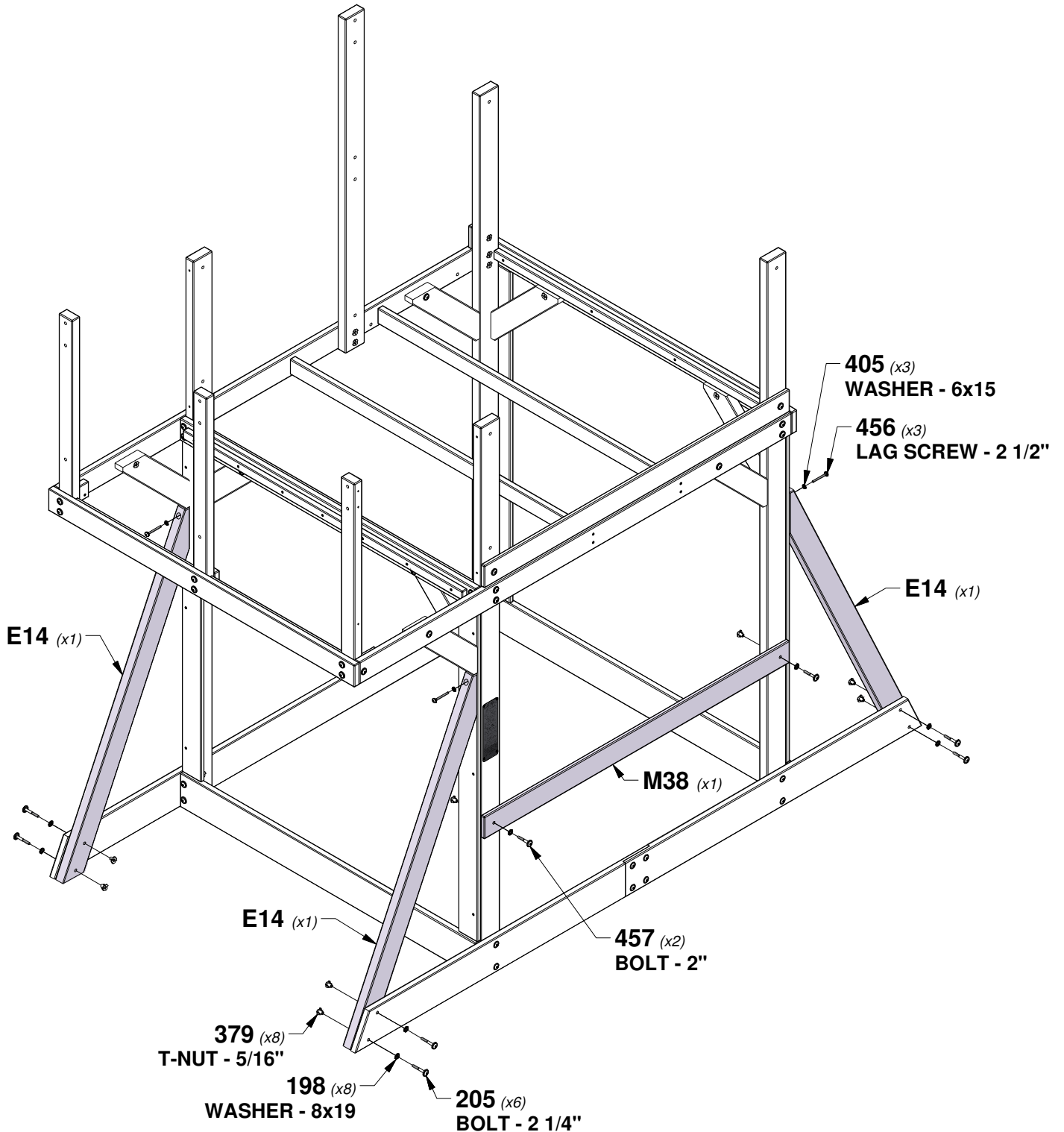

STEP 17 - FORT ASSEMBLY

QTY	PART NUMBER	DESCRIPTION
58	H100086	SCREW PFH 8x1-1/2"

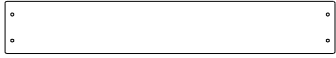

M14 | FLOOR BOARD - W4L16828
(x13) | 5/8"x3 3/8"x21 1/2" (16x86x546)

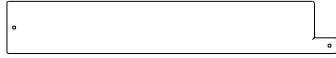

M15 | FLOOR BOARD - W4L16589
(x1) | 5/8"x3 3/8"x21 1/2" (16x86x546)

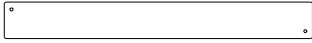

N5 | FLOOR BOARD - W4L06451
(x2) | 5/8"x2 3/8"x20 1/8" (16x60x510)

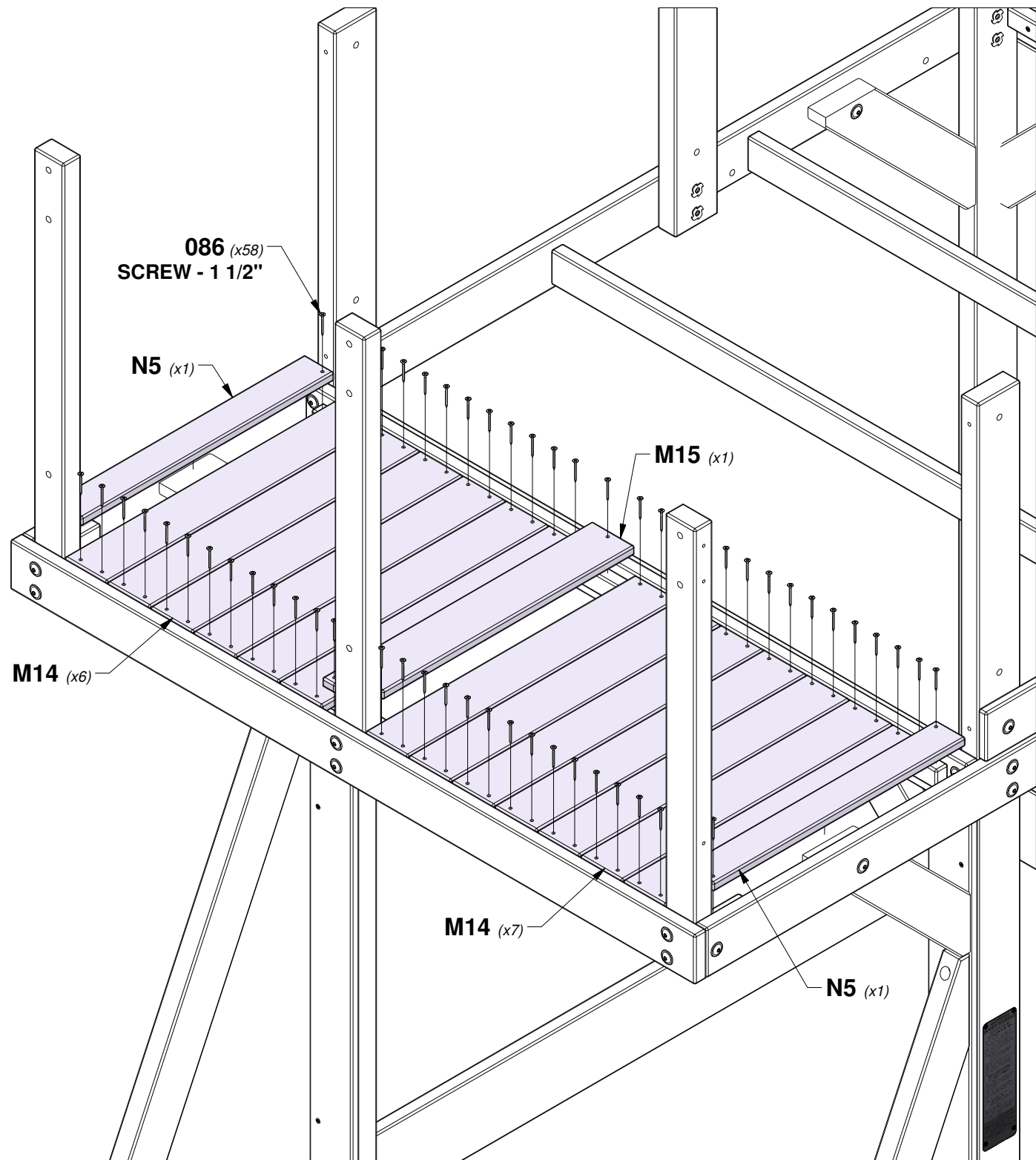

STEP 18 - FORT ASSEMBLY

QTY	PART NUMBER	DESCRIPTION
92	H100086	SCREW PFH 8x1-1/2"

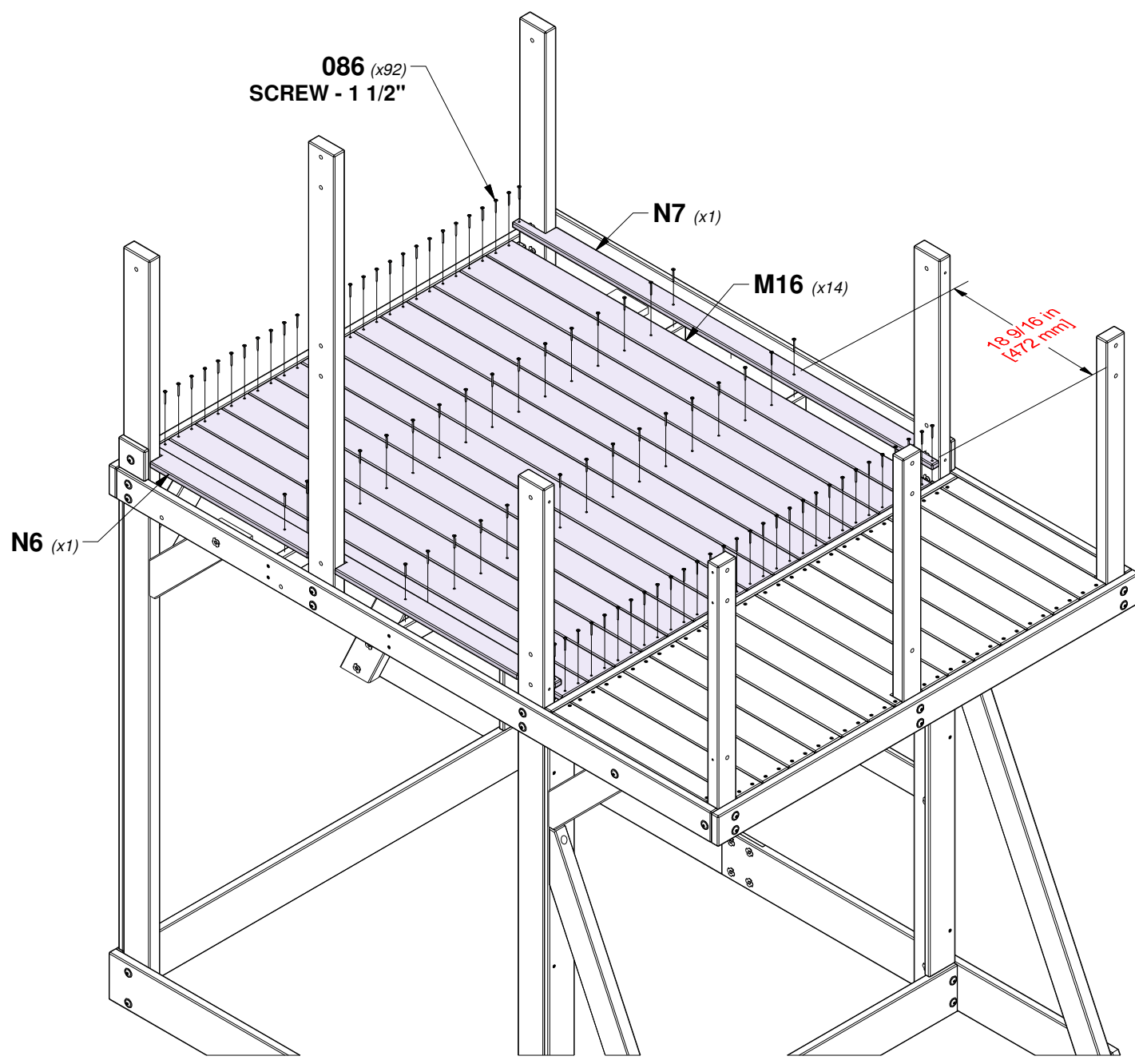
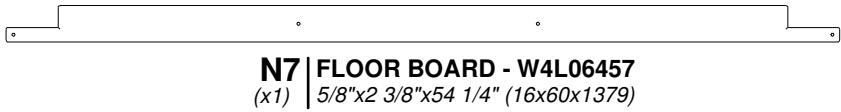
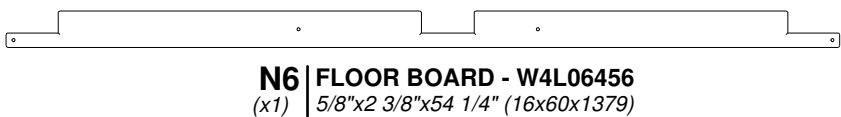
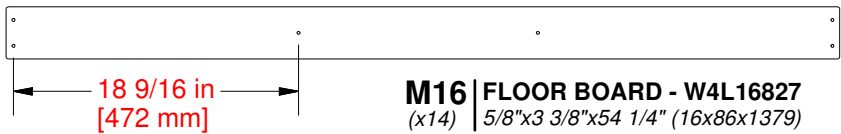

STEP 19 - FORT ASSEMBLY

QTY	PART NUMBER	DESCRIPTION
4	H100198	WASHER LOCK EXT 8x19 BLK
2	H100379	T-NUT 5/16 BLK
2	H100457	BOLT WH 5/16x2 BLK
2	H100458	LAG SCREW WH 5/16x2 BLK



M19 | WALL RAIL - W4L16838
(x1) | 5/8"x3 3/8"x29 1/4" (16x86x744)



M20 | WALL RAIL - W4L06464
(x1) | 5/8"x3 3/8"x5 3/8" (16x86x138)



M22 | WALL RAIL - W4L06466
(x1) | 5/8"x3 3/8"x30 1/2" (16x86x774)

TIP:
INSTALL T-NUTS IN WOOD FIRST

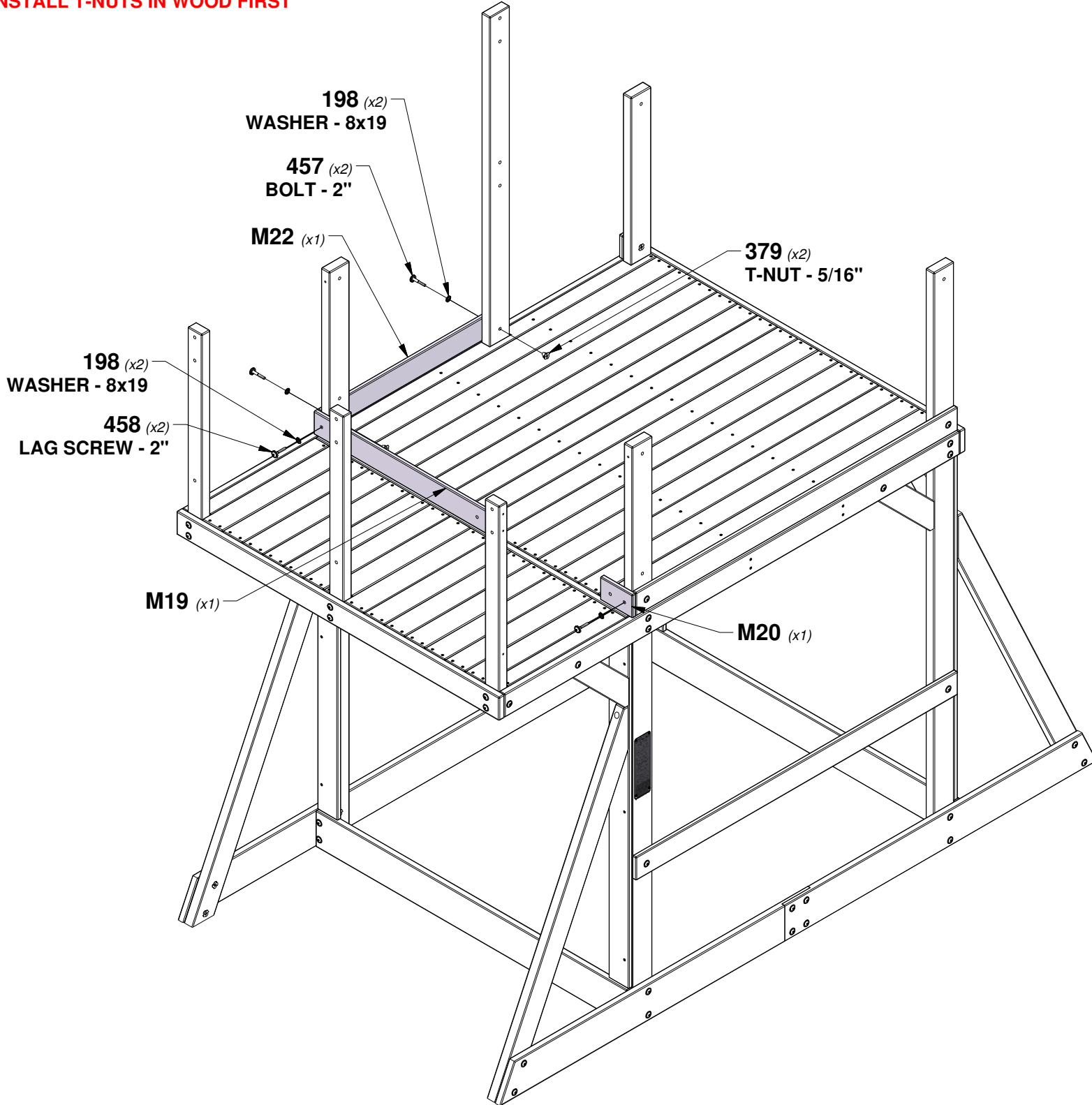

STEP 20 - FORT ASSEMBLY

QTY	PART NUMBER	DESCRIPTION
2	H100198	WASHER LOCK EXT 8x19 BLK
2	H100458	LAG SCREW WH 5/16x2 BLK



M24 | WALL RAIL - W4L16836
 (x2) | 5/8"x3 3/8"x15 5/8" (16x86x398)

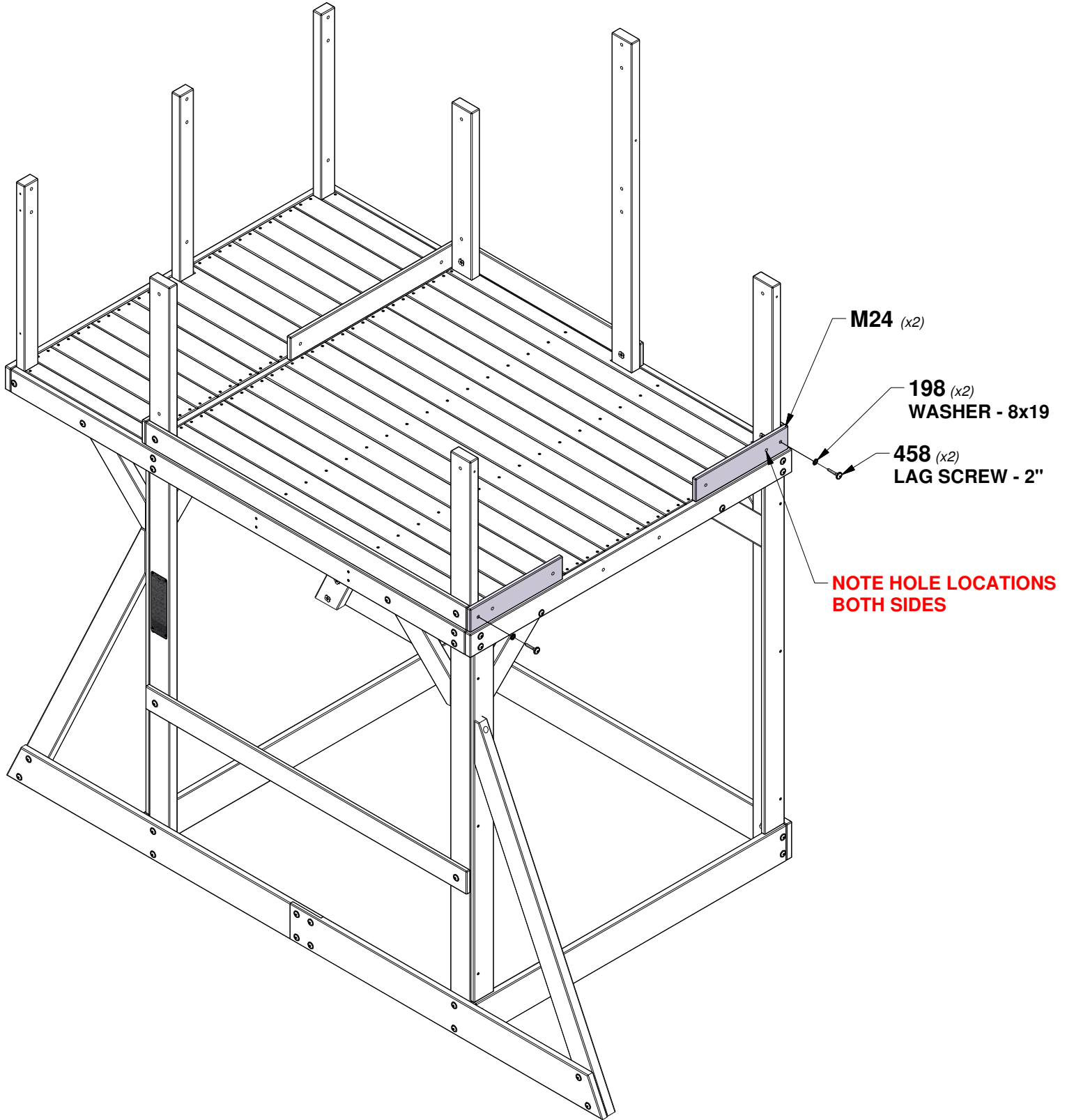

**NOTE HOLE LOCATIONS
 BOTH SIDES**

STEP 21 - FORT ASSEMBLY

QTY	PART NUMBER	DESCRIPTION
6	H100198	WASHER LOCK EXT 8x19 BLK
4	H100379	T-NUT 5/16 BLK
4	H100457	BOLT WH 5/16x2 BLK
2	H100471	LAG SCREW WH 5/16x1-1/2 BLK



M17 | WALL RAIL - W4L16590
(x1) 5/8"x3 3/8"x26 7/8" (16x86x683)



M18 | WALL RAIL - W4L06461
(x2) 5/8"x3 3/8"x25 7/8" (16x86x658)

TIP:
INSTALL T-NUTS IN WOOD FIRST

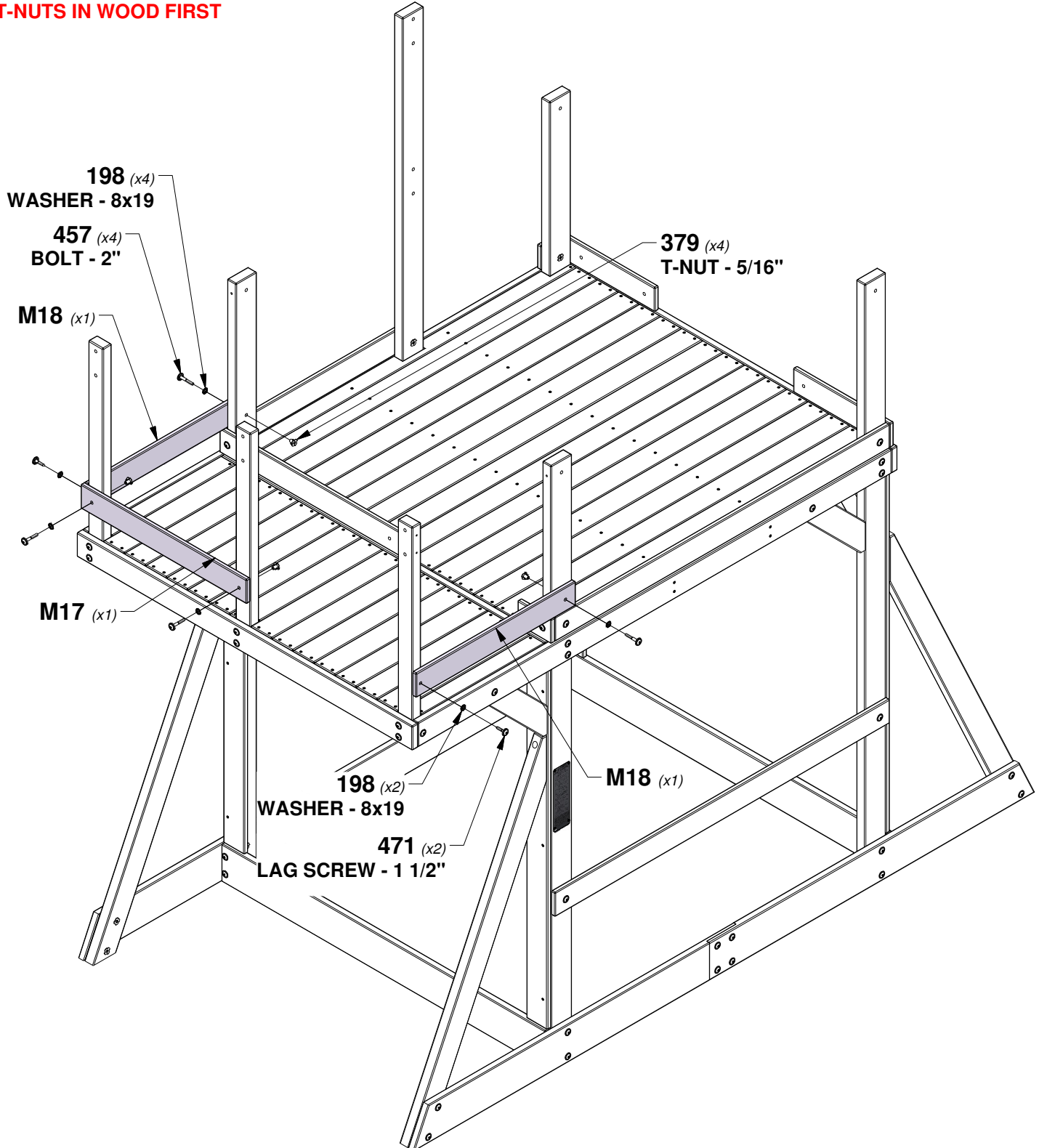

STEP 22 - FORT ASSEMBLY

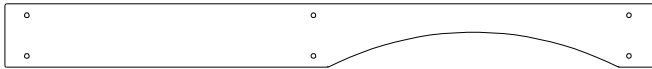

K8 | **ARCHED WALL RAIL - W4L16591**
(x1) | 5/8"x5 1/4"x54 1/8" (16x134x1375)



K10 | **WALL RAIL - W4L06462**
(x1) | 5/8"x5 1/4"x53" (16x134x1346)



G1 | **WALL RAIL - W4L06469**
(x1) | 1"x5 1/4"x76 7/8" (24x134x1952)



K11 | **WALL RAIL - W4L06470**
(x1) | 5/8"x5 1/4"x3 3/8" (16x134x86)

QTY	PART NUMBER	DESCRIPTION
16	H100198	WASHER LOCK EXT 8x19 BLK
2	H100205	BOLT WH 5/16x2-1/4 BLK
14	H100379	T-NUT 5/16 BLK
10	H100457	BOLT WH 5/16x2 BLK
2	H100458	LAG SCREW WH 5/16x2 BLK
2	H100471	LAG SCREW WH 5/16x1-1/2 BLK

TIP:
INSTALL T-NUTS IN WOOD FIRST

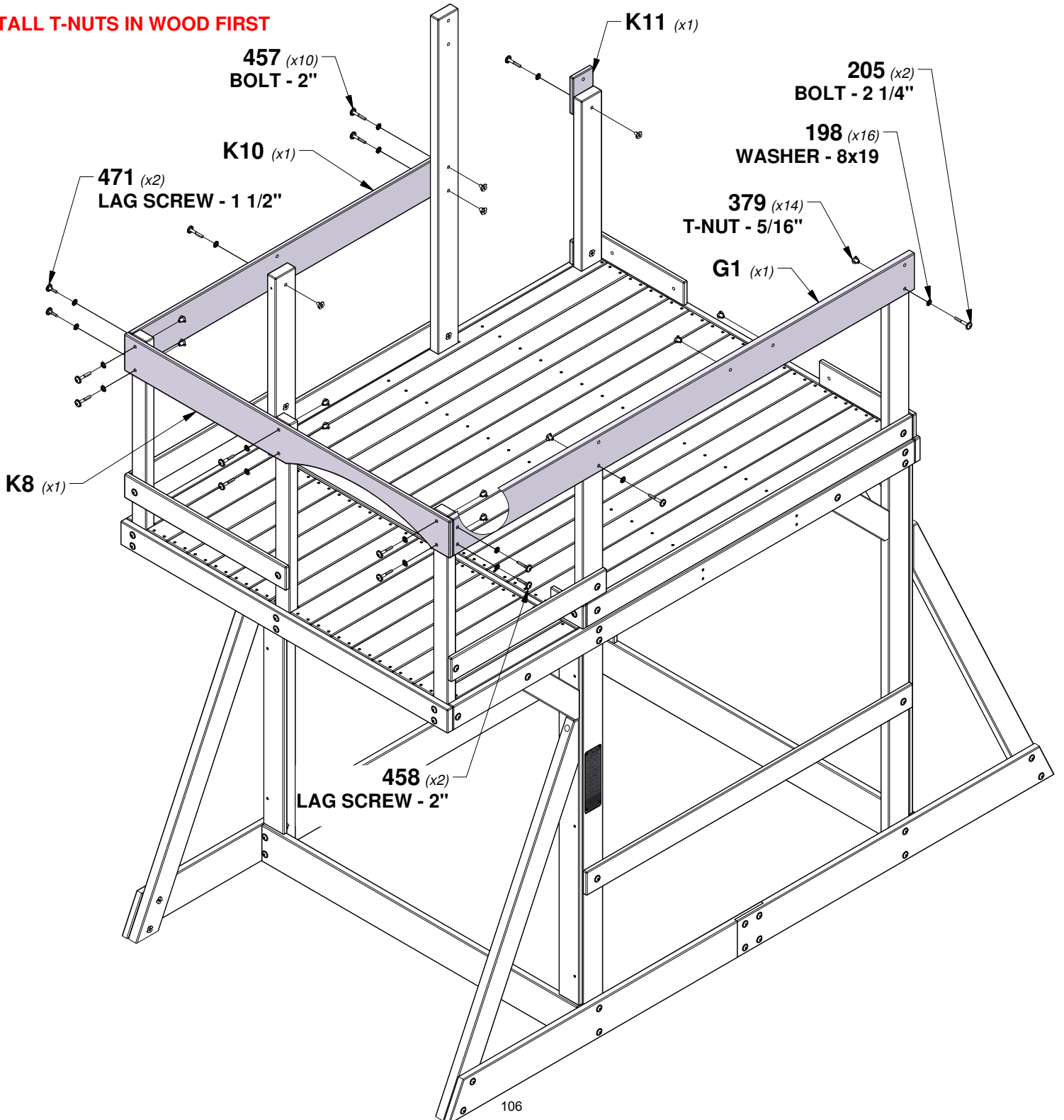

STEP 23 - FORT ASSEMBLY

QTY	PART NUMBER	DESCRIPTION
2	H100198	WASHER LOCK EXT 8x19 BLK
2	H100458	LAG SCREW WH 5/16x2 BLK



K12 | **ARCHED WALL RAIL - W4L06471**
(x1) 5/8"x5 1/4"x54 1/8" (16x134x1375)

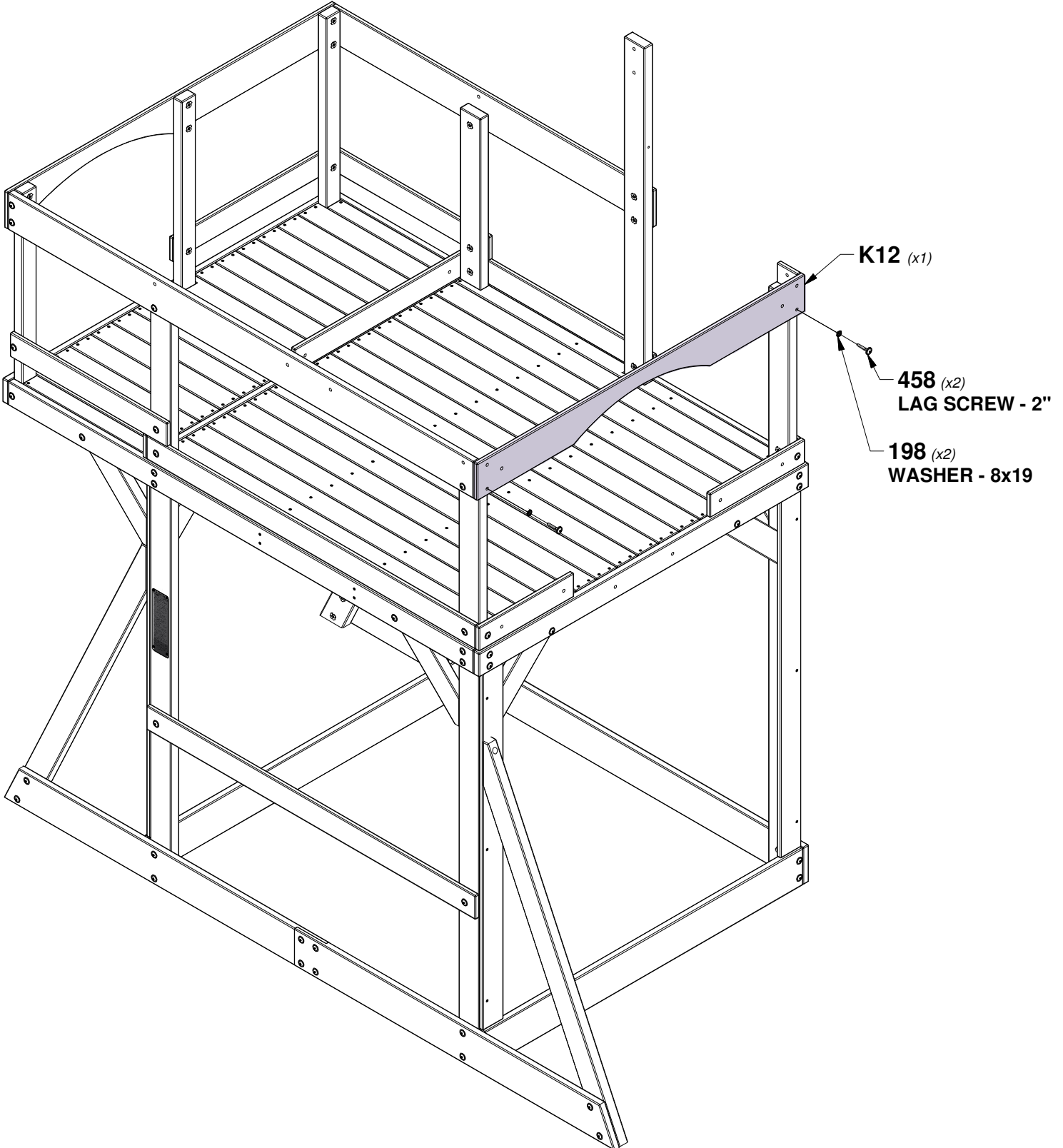

STEP 24 - FORT ASSEMBLY

QTY	PART NUMBER	DESCRIPTION
6	H100198	WASHER LOCK EXT 8x19 BLK
2	H100205	BOLT WH 5/16x2-1/4 BLK
4	H100379	T-NUT 5/16 BLK
2	H100457	BOLT WH 5/16x2 BLK
2	H100458	LAG SCREW WH 5/16x2 BLK



E11 | RIGHT FORT UPRIGHT - W4L16902
(x2) | 1 3/8"x3 3/8"x23 3/4" (36x86x602)



E12 | LEFT FORT UPRIGHT - W4L16885
(x1) | 1 3/8"x3 3/8"x23 3/4" (36x86x602)



E15 | FORT UPRIGHT - W4L16593
(x1) | 1 3/8"x3 3/8"x23 3/4" (36x86x602)

TIP:
INSTALL T-NUTS IN WOOD FIRST

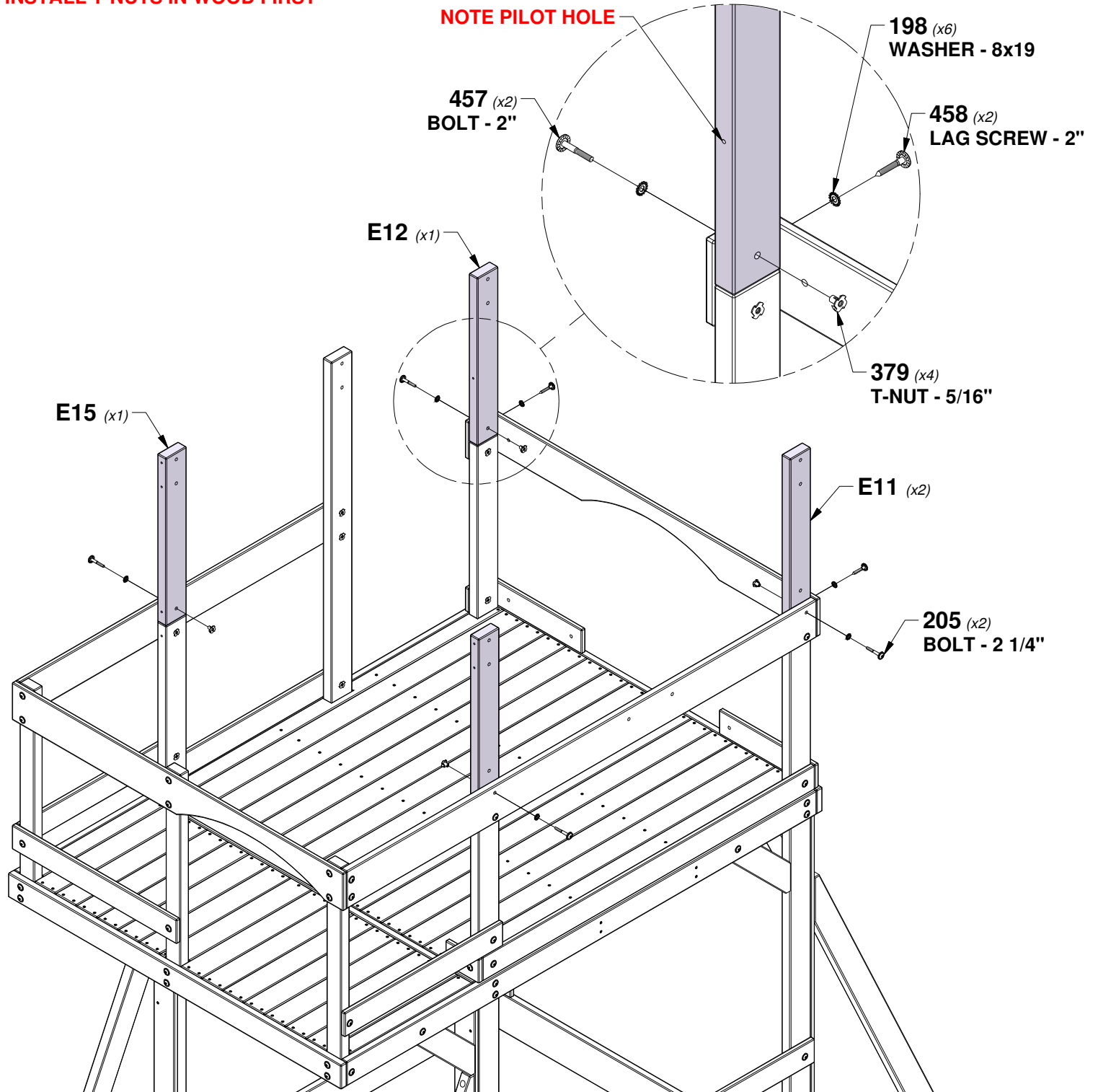

STEP 25 - FORT ASSEMBLY

QTY	PART NUMBER	DESCRIPTION
4	H100198	WASHER LOCK EXT 8x19 BLK
4	H100458	LAG SCREW WH 5/16x2 BLK



K13 | WALL RAIL - W4L06473
(x1) | 5/8"x5 1/4"x28 5/8" (16x134x728)



K14 | WALL RAIL - W4L06474
(x1) | 5/8"x5 1/4"x4 3/4" (16x134x122)

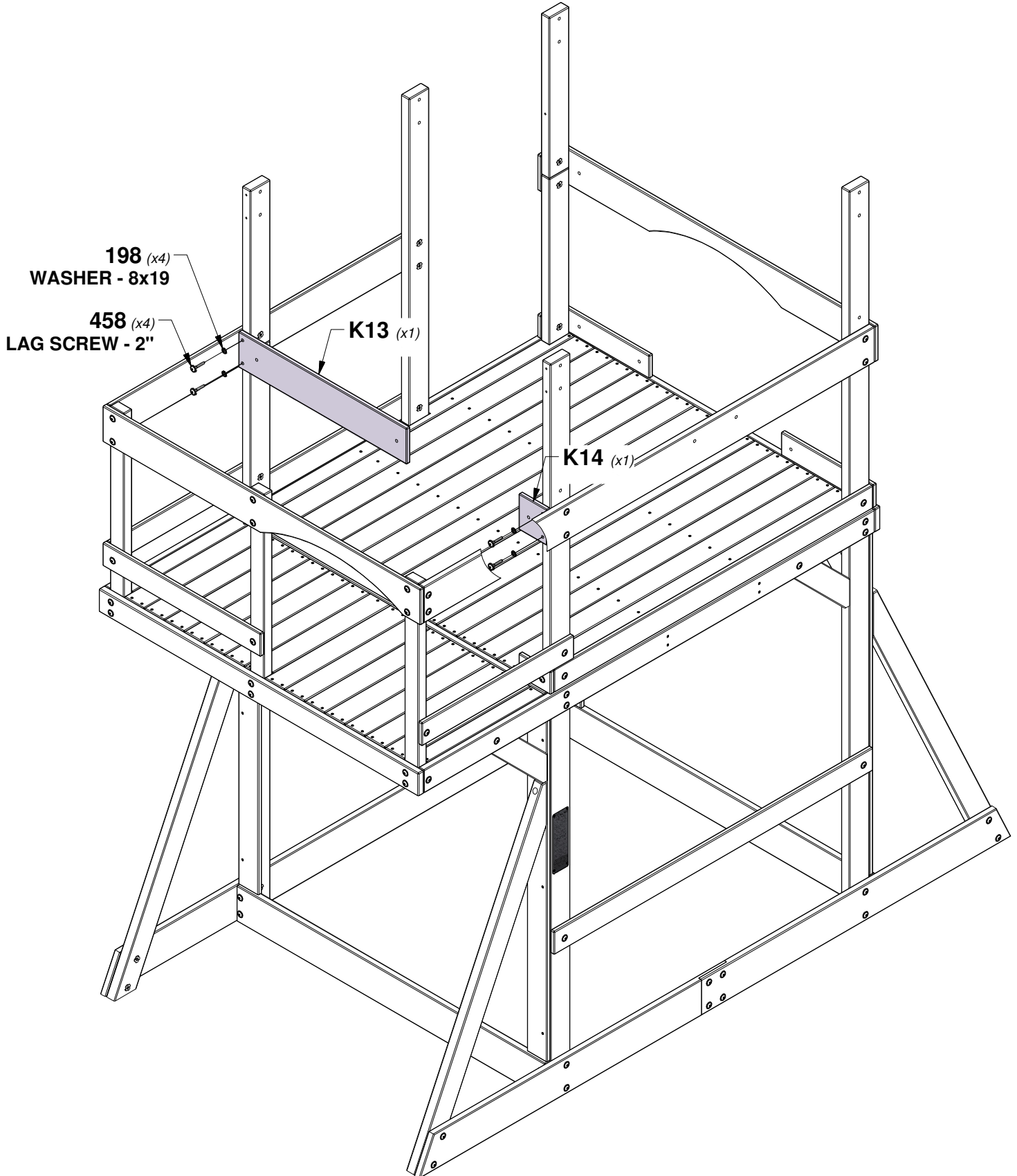

STEP 26 - FORT ASSEMBLY

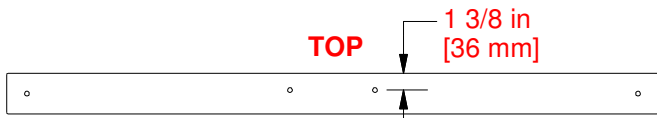

H13 | SWING BEAM MOUNT - W4L06533
(x1) | 1"x3 3/8"x54 3/8" (24x86x1380)

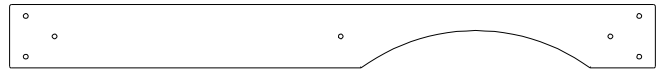

K15 | ARCHED WALL RAIL - W4L06479
(x1) | 5/8"x5 1/4"x53 7/8" (16x134x1367)

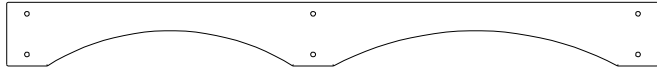

K16 | ARCHED WALL RAIL - W4L06530
(x1) | 5/8"x5 1/4"x54 3/8" (16x134x1380)

QTY	PART NUMBER	DESCRIPTION
2	H100074	T-NUT 5/16
16	H100198	WASHER LOCK EXT 8x19 BLK
2	H100205	BOLT WH 5/16x2-1/4 BLK
12	H100379	T-NUT 5/16 BLK
10	H100457	BOLT WH 5/16x2 BLK
4	H100458	LAG SCREW WH 5/16x2 BLK



K17 | ARCHED WALL RAIL - W4L06531
(x1) | 5/8"x5 1/4"x53 7/8" (16x134x1367)



K18 | WALL RAIL - W4L06532
(x1) | 5/8"x5 1/4"x54 3/8" (16x134x1380)

TIP:
INSTALL T-NUTS IN WOOD FIRST

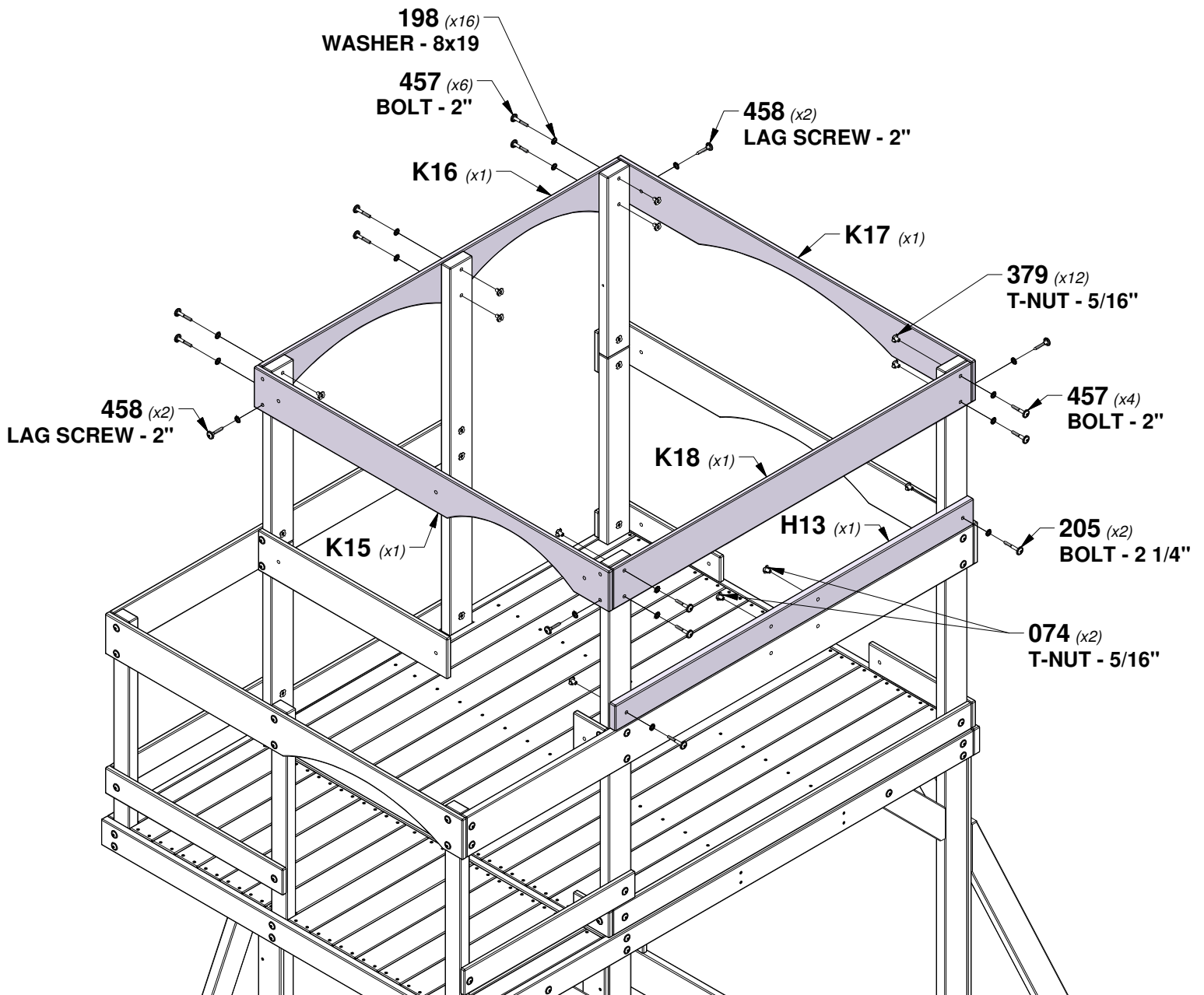

STEP 27 - FORT ASSEMBLY

QTY	PART NUMBER	DESCRIPTION
28	H100088	SCREW PFH 8x1-1/8"



M30 | WALL BOARD - W4L06537
(x7) 5/8"x3 3/8"x26 7/8" (16x86x684)

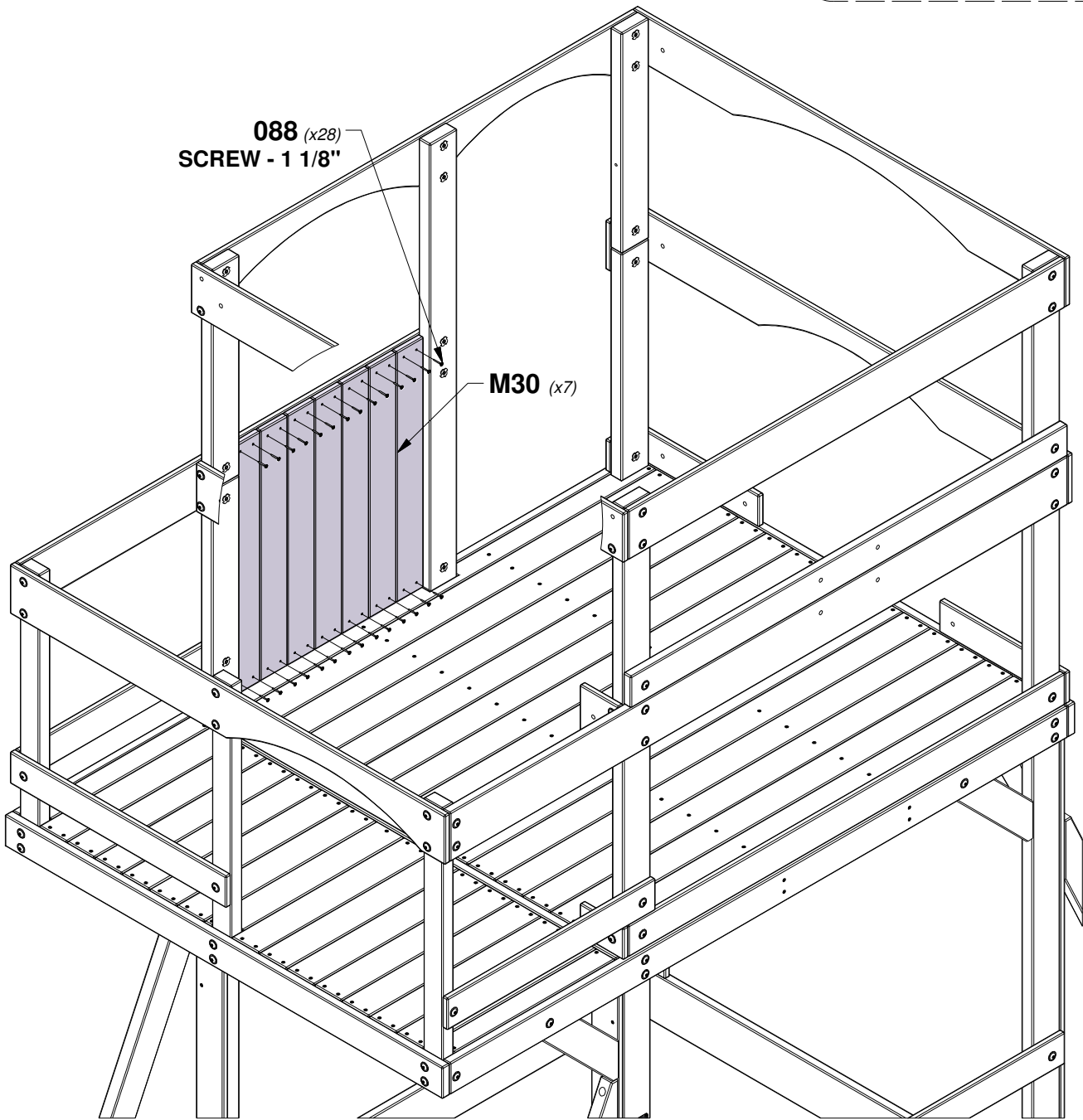
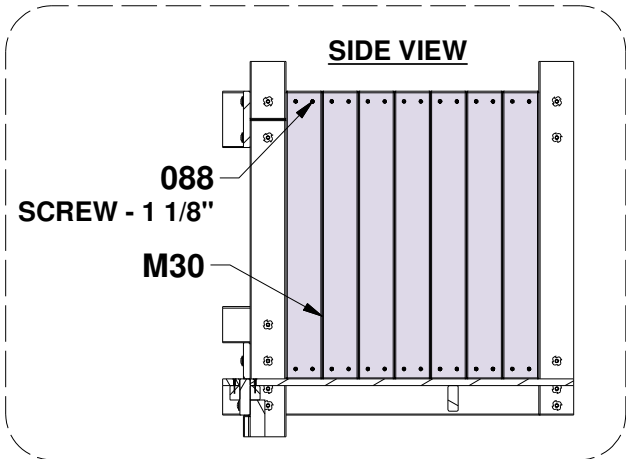

STEP 28A - FORT ASSEMBLY



M26 | WALL BOARD - W4L16835
(x2) | 5/8"x3 3/8"x26 7/8" (16x86x684)

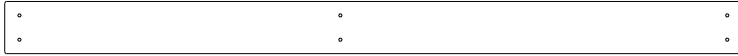

M27 | WALL BOARD - W4L06534
(x4) | 5/8"x3 3/8"x48" (16x86x1219)



H12 | WALL BOARD - W4L06472
(x2) | 1"x3 3/8"x48" (24x86x1219)

QTY	PART NUMBER	DESCRIPTION
32	H100088	SCREW PFH 8x1-1/8"
6	H100198	WASHER LOCK EXT 8x19 BLK
6	H100379	T-NUT 5/16 BLK
6	H100407	BOLT WH 5/16x1 1/2 BLK

TIP:
INSTALL T-NUTS IN WOOD FIRST

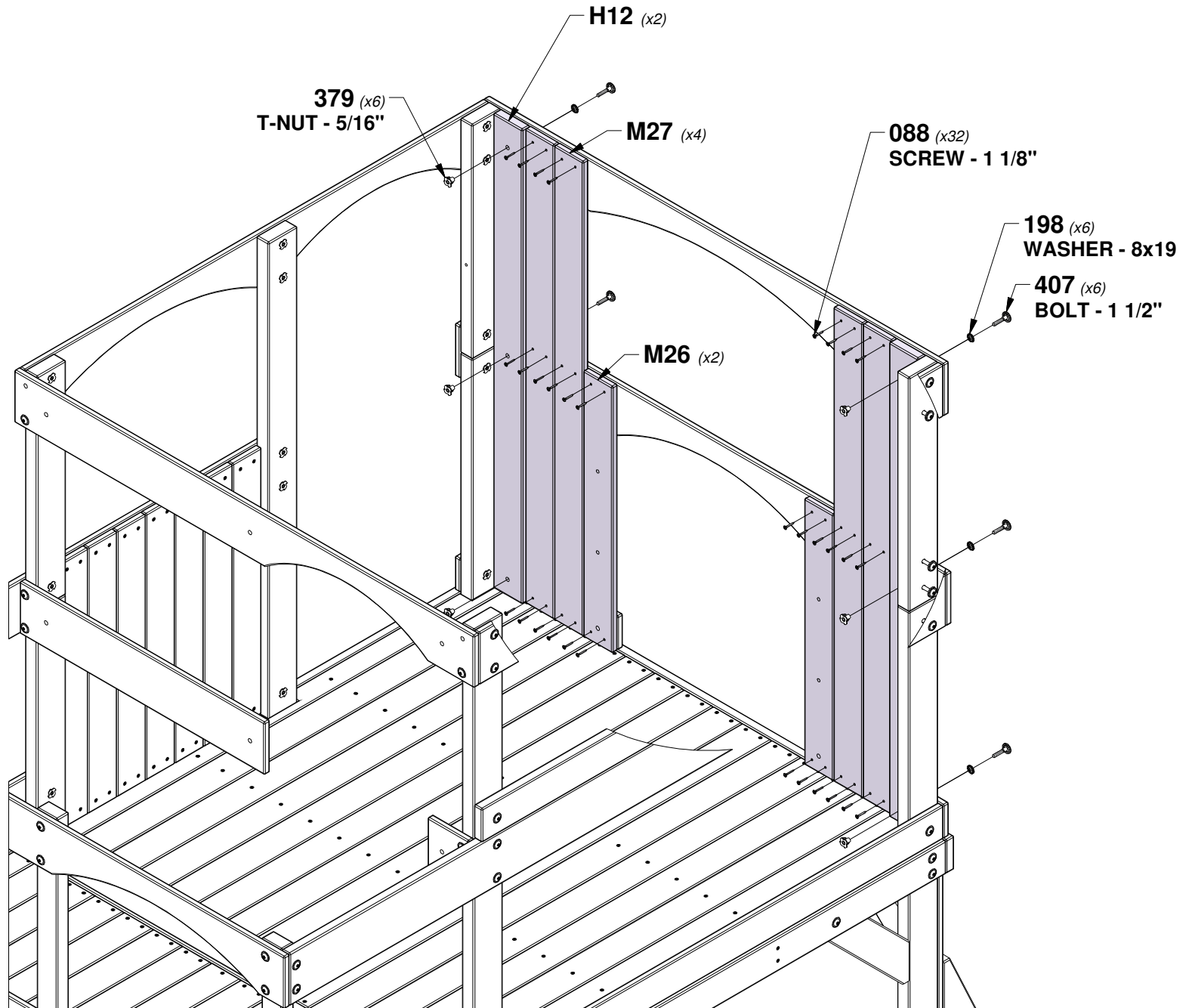

STEP 28B - FORT ASSEMBLY

QTY	PART NUMBER	DESCRIPTION
4	H100171	BOLT WH 1/4x1 BLK
2	H100192	NUT BARREL WH 5/16x7/8 BLK
2	H100199	WASHER LOCK EXT 12x19 BLK
2	H100379	T-NUT 5/16 BLK
2	H100396	BOLT WH 5/16x1/2 BLK
4	H100398	T-NUT 1/4 BLK
4	H100405	WASHER LOCK EXT 6x15 BLK
2	H100468	BOLT WH 5/16x1 BLK

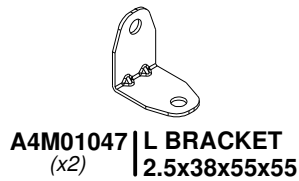

TIP:
INSTALL T-NUTS IN WOOD FIRST

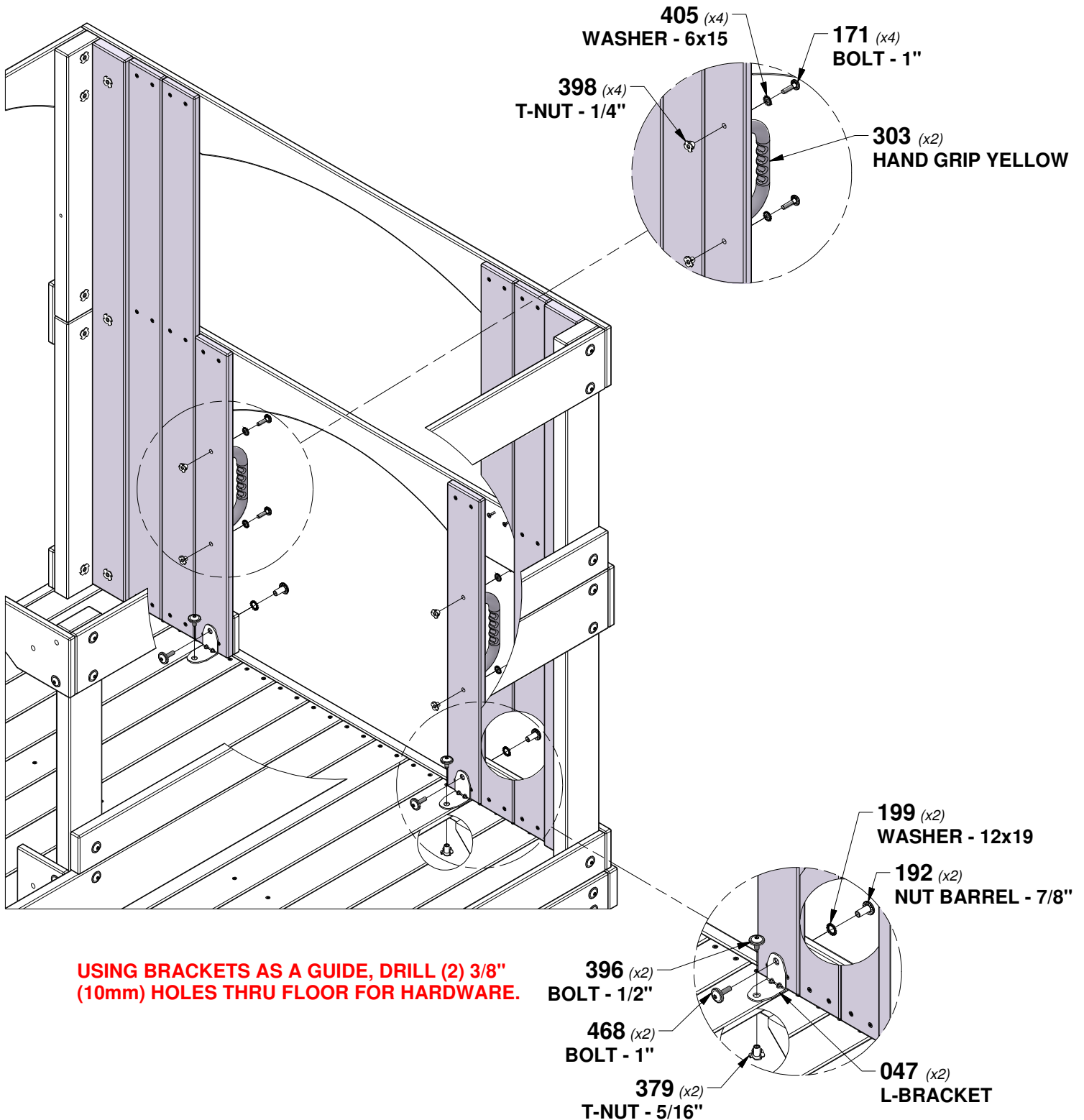

STEP 29 - FORT ASSEMBLY

QTY	PART NUMBER	DESCRIPTION
56	H100088	SCREW PFH 8x1-1/8"



M30 | WALL BOARD - W4L06537
(x14) | 5/8"x3 3/8"x26 7/8" (16x86x684)

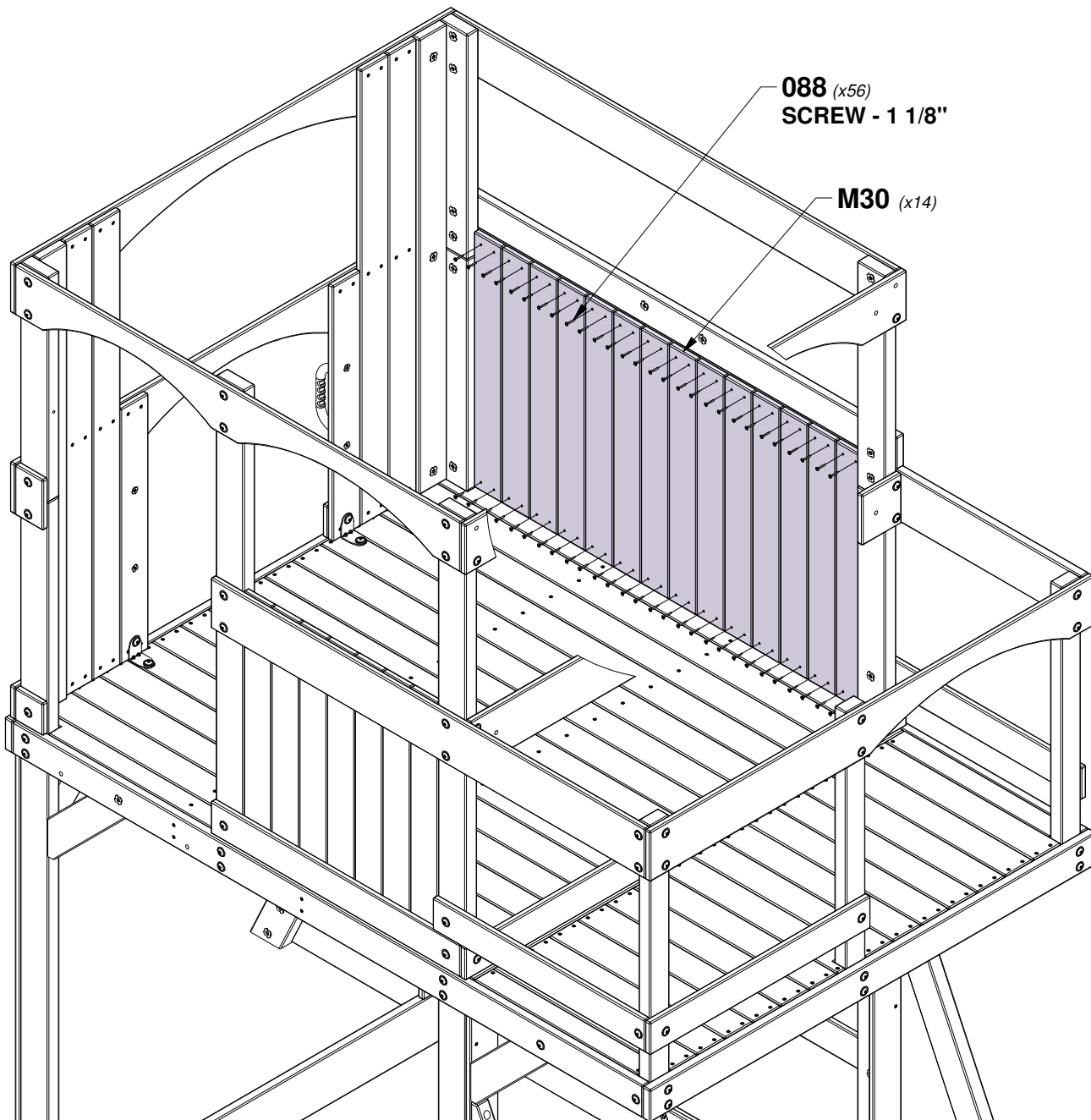

STEP 30 - FORT ASSEMBLY

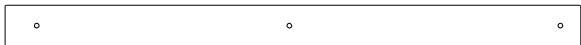

H12 | WALL BOARD - W4L06472
(x2) | 1"x3 3/8"x48" (24x86x1219)



M25 | WALL BOARD - W4L16837
(x1) | 5/8"x3 3/8"x48" (16x86x1219)



M27 | WALL BOARD - W4L06534
(x4) | 5/8"x3 3/8"x48" (16x86x1219)



M28 | WALL BOARD - W4L06535
(x2) | 5/8"x3 3/8"x29 7/8" (16x86x760)



A4M01047 | L BRACKET
(x2) | 2.5x38x55x55



M29 | WALL BOARD - W4L06536
(x2) | 5/8"x3 3/8"x8 1/4" (16x86x210)

QTY	PART NUMBER	DESCRIPTION
36	H100088	SCREW PFH 8x1-1/8"
1	H100192	NUT BARREL WH 5/16x7/8 BLK
8	H100198	WASHER LOCK EXT 8x19 BLK
1	H100199	WASHER LOCK EXT 12x19 BLK
9	H100379	T-NUT 5/16 BLK
1	H100396	BOLT WH 5/16x1/2 BLK
6	H100407	BOLT WH 5/16x1 1/2 BLK
2	H100459	BOLT WH 5/16x1 1/4 BLK
1	H100468	BOLT WH 5/16x1 BLK

TIP:
INSTALL T-NUTS IN WOOD FIRST

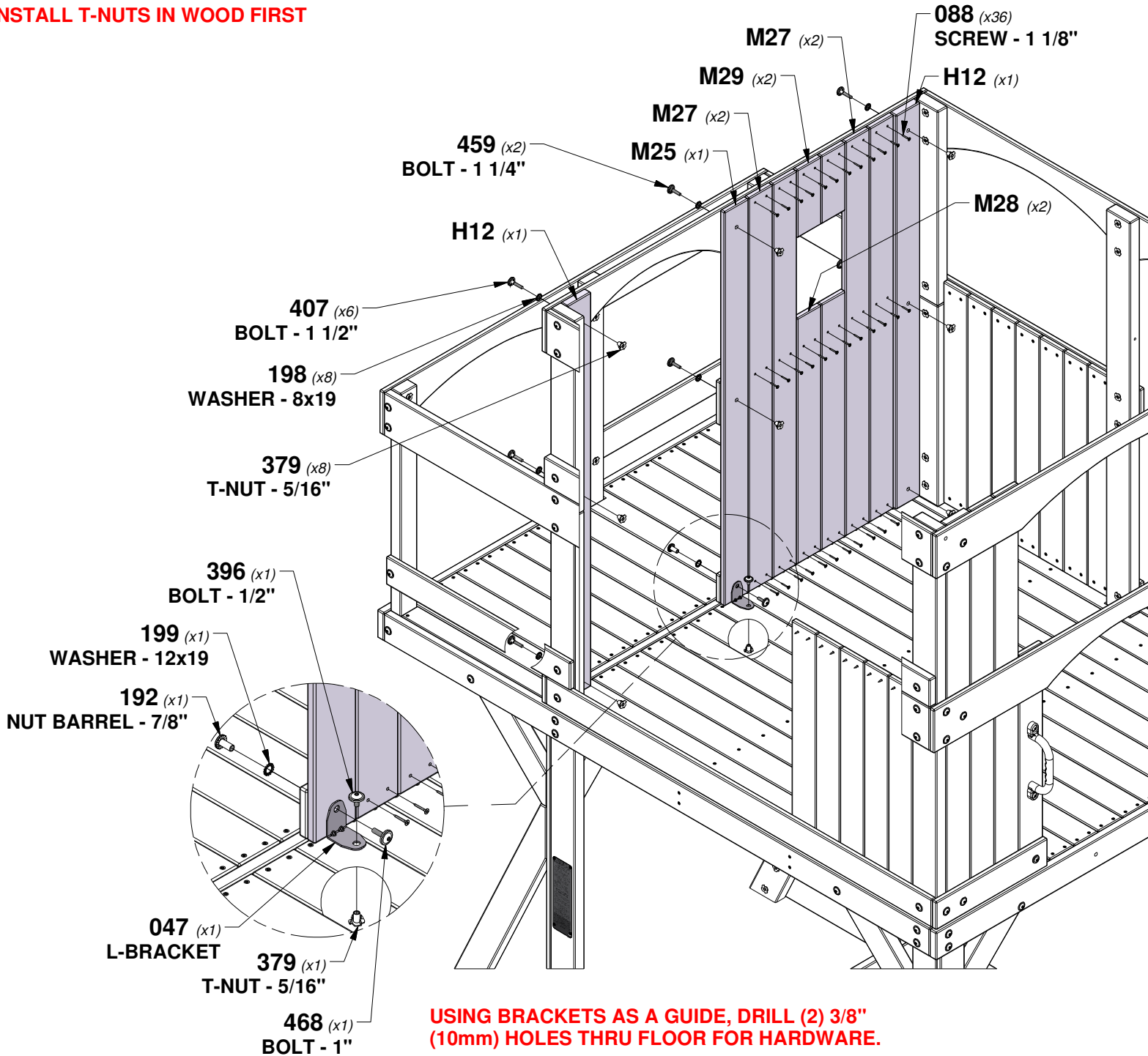

STEP 31 - FORT ASSEMBLY

QTY	PART NUMBER	DESCRIPTION
4	H100128	SCREW PWH 8x5/8

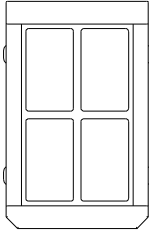

A6P00019
(x1) | WINDOW (FLAT PACK)

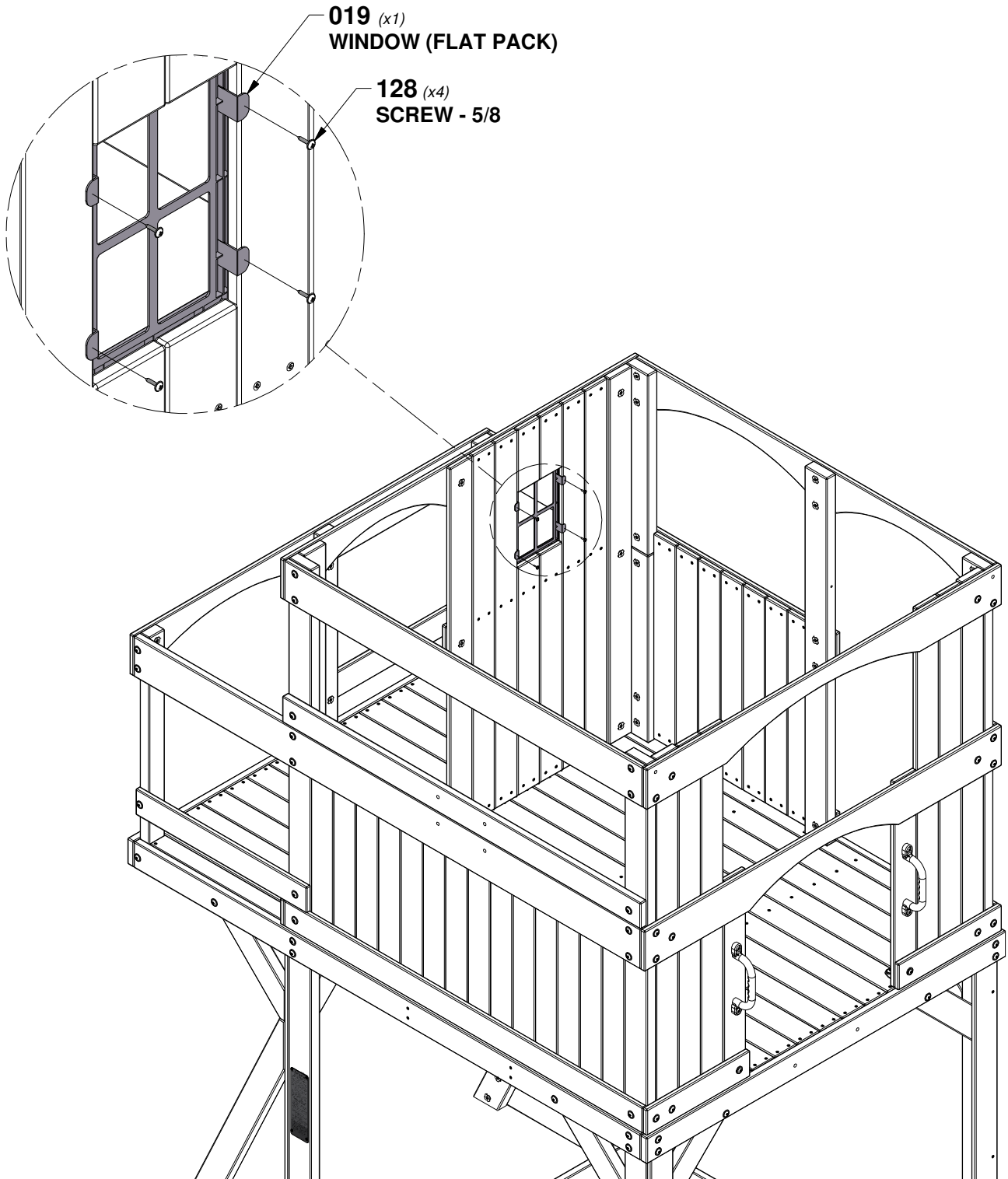

STEP 32 - FORT ASSEMBLY

QTY	PART NUMBER	DESCRIPTION
2	H100090	SCREW PFH 8x2 1/2
4	H100197	LAG SCREW WH 5/16x2-1/2 BLK
4	H100198	WASHER LOCK EXT 8x19 BLK

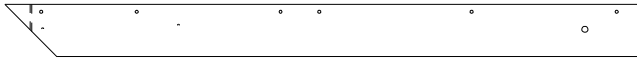

M31 | GABLE BOARD - W4L06538
(x2) | 5/8"x3 3/8"x41 3/8" (16x86x1052)

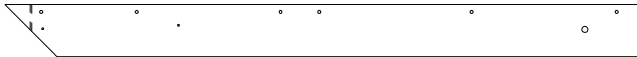

M32 | GABLE BOARD - W4L06539
(x2) | 5/8"x3 3/8"x41 3/8" (16x86x1052)

NOTE PILOT HOLE TO INSIDE (BOTH SIDES)

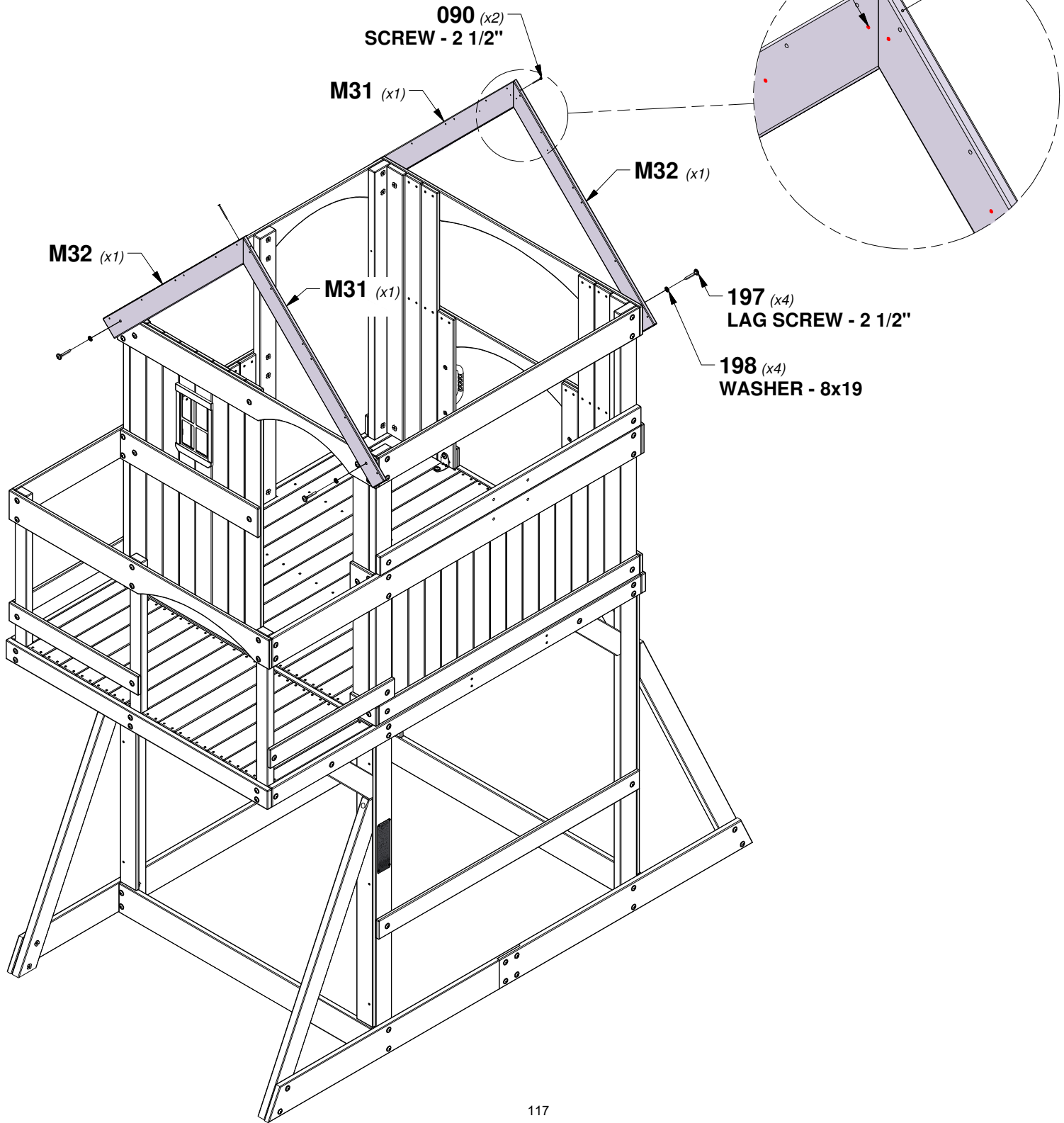

STEP 33 - FORT ASSEMBLY

QTY	PART NUMBER	DESCRIPTION
8	H100070	SCREW PWH 8x3/4
12	H100088	SCREW PFH 8x1-1/8"

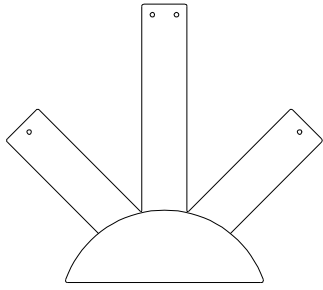

A100361 | PLASTIC SUNBURST
(x2)



N8 | GABLE BOARD - W4L06558
(x2) | 5/8"x2 3/8"x34 3/4" (16x60x884)

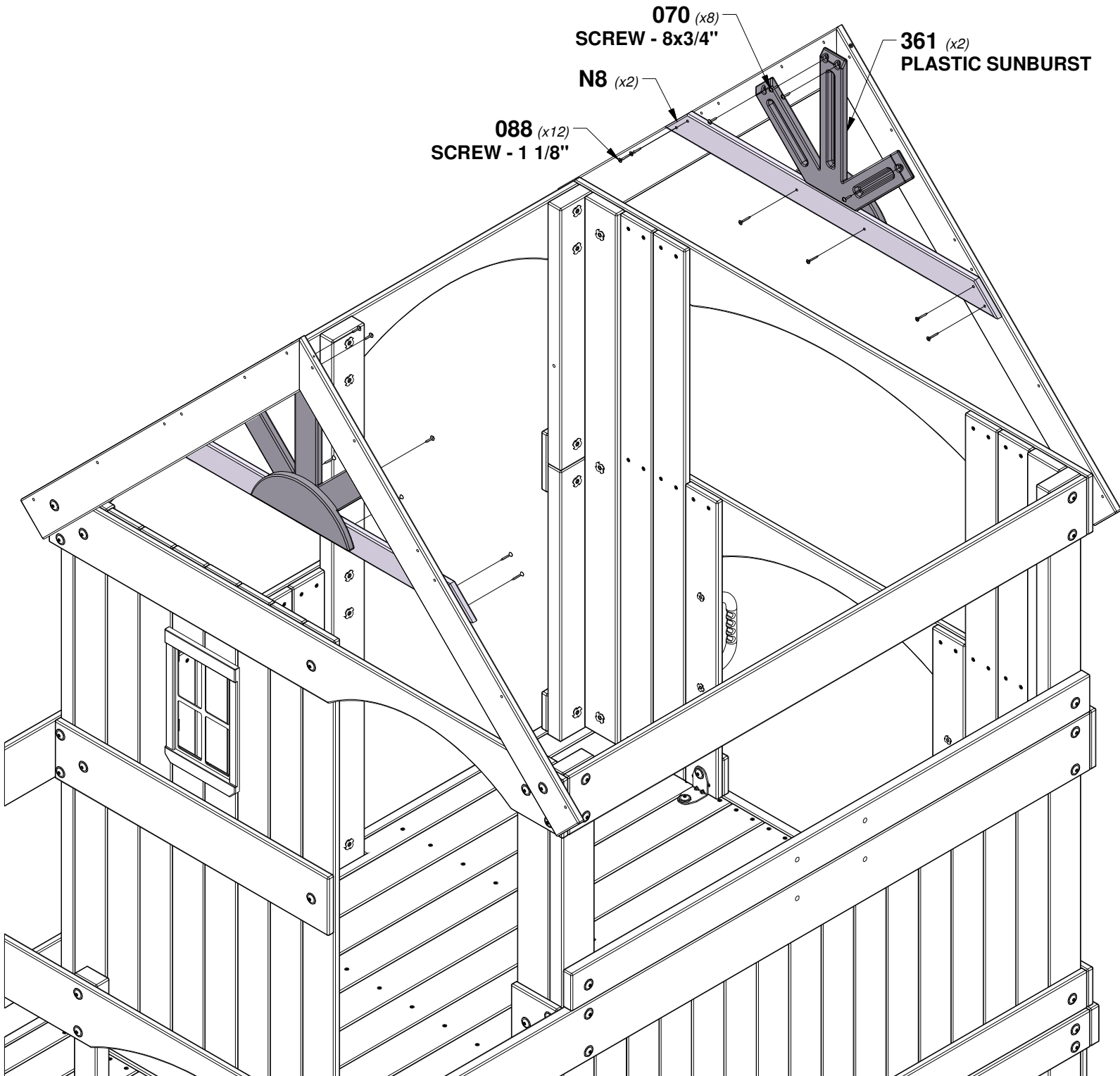

STEP 34 - FORT ASSEMBLY

QTY	PART NUMBER	DESCRIPTION
12	H100089	SCREW PFH 8x1-3/4"

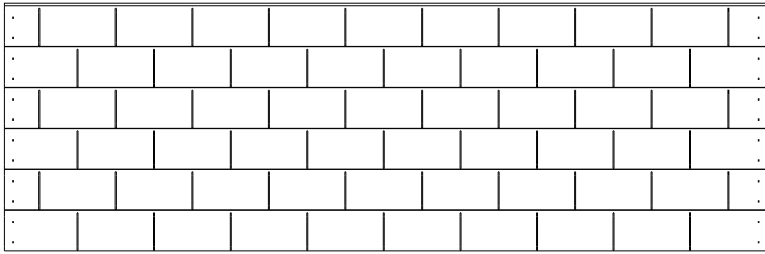

RP4 UPPER ROOF PANEL - W2A03482
 (x2) | 1 3/8"x19 3/8"x59 5/8" (35x491x1514)

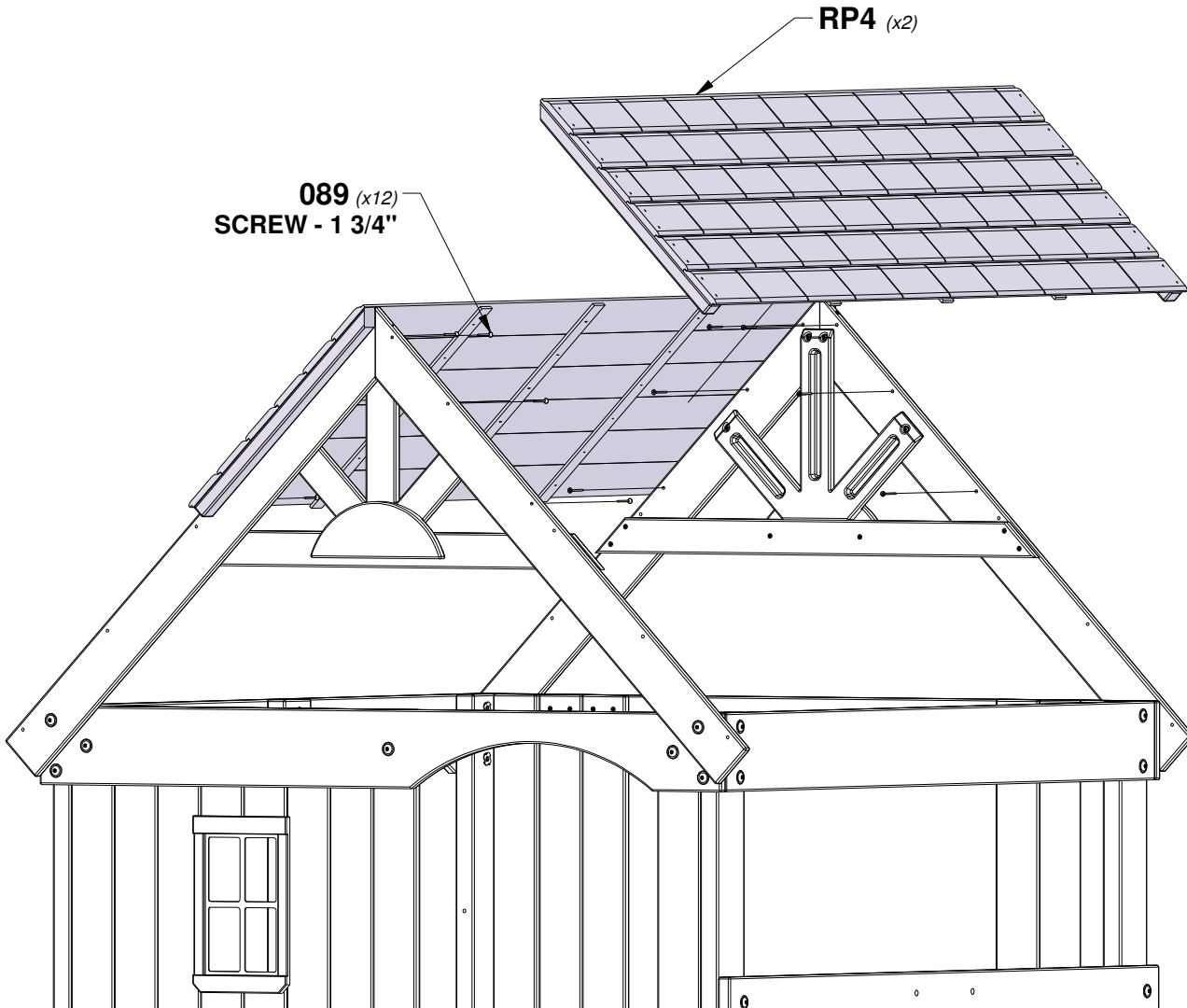
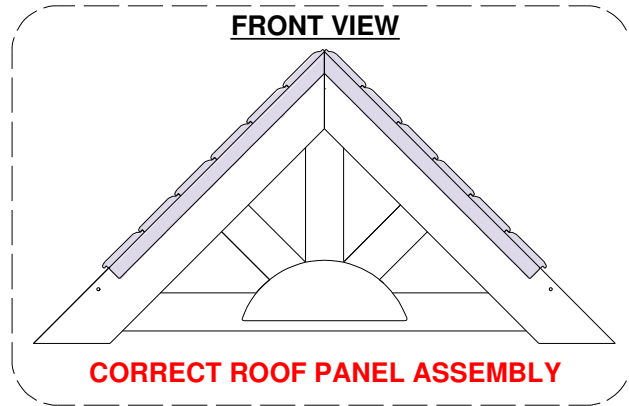

STEP 35 - FORT ASSEMBLY

QTY	PART NUMBER	DESCRIPTION
12	H100089	SCREW PFH 8x1-3/4"

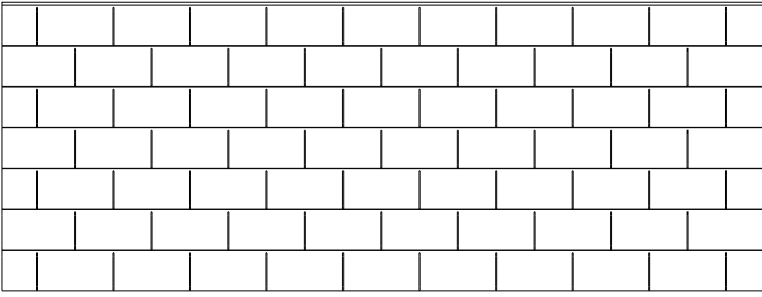

RP3 LOWER ROOF PANEL - W2A03483
(x2) 1 3/8"x22 1/2"x59 5/8" (35x572x1514)

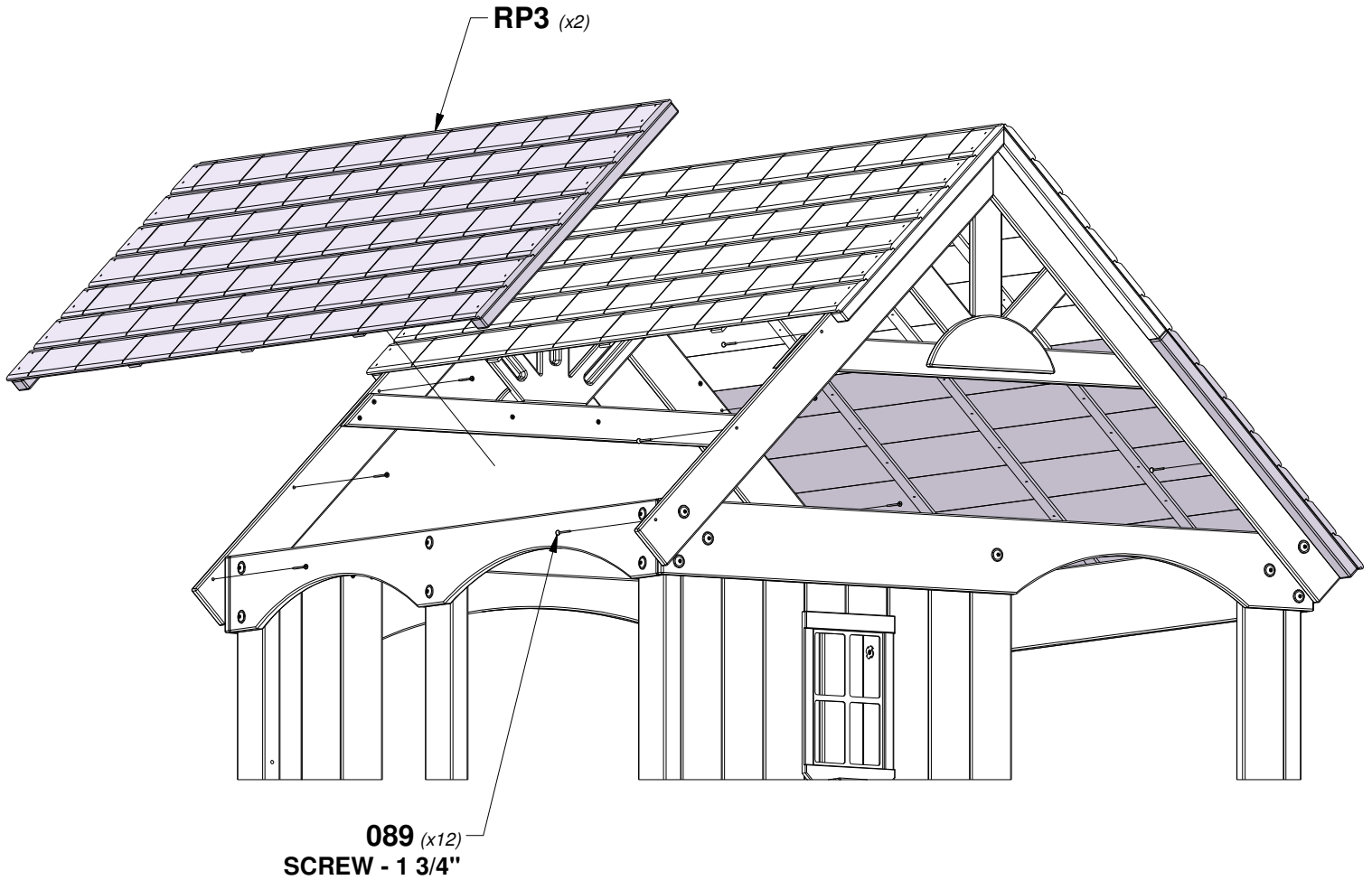

STEP 36 - FORT ASSEMBLY

QTY	PART NUMBER	DESCRIPTION
12	H100387	SCREW PFH 8x1-1/4 BLK

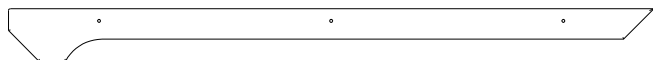

M34 | FASCIA BOARD - W4L06560
(x4) | 5/8"x3 3/8"x42" (16x86x1068)

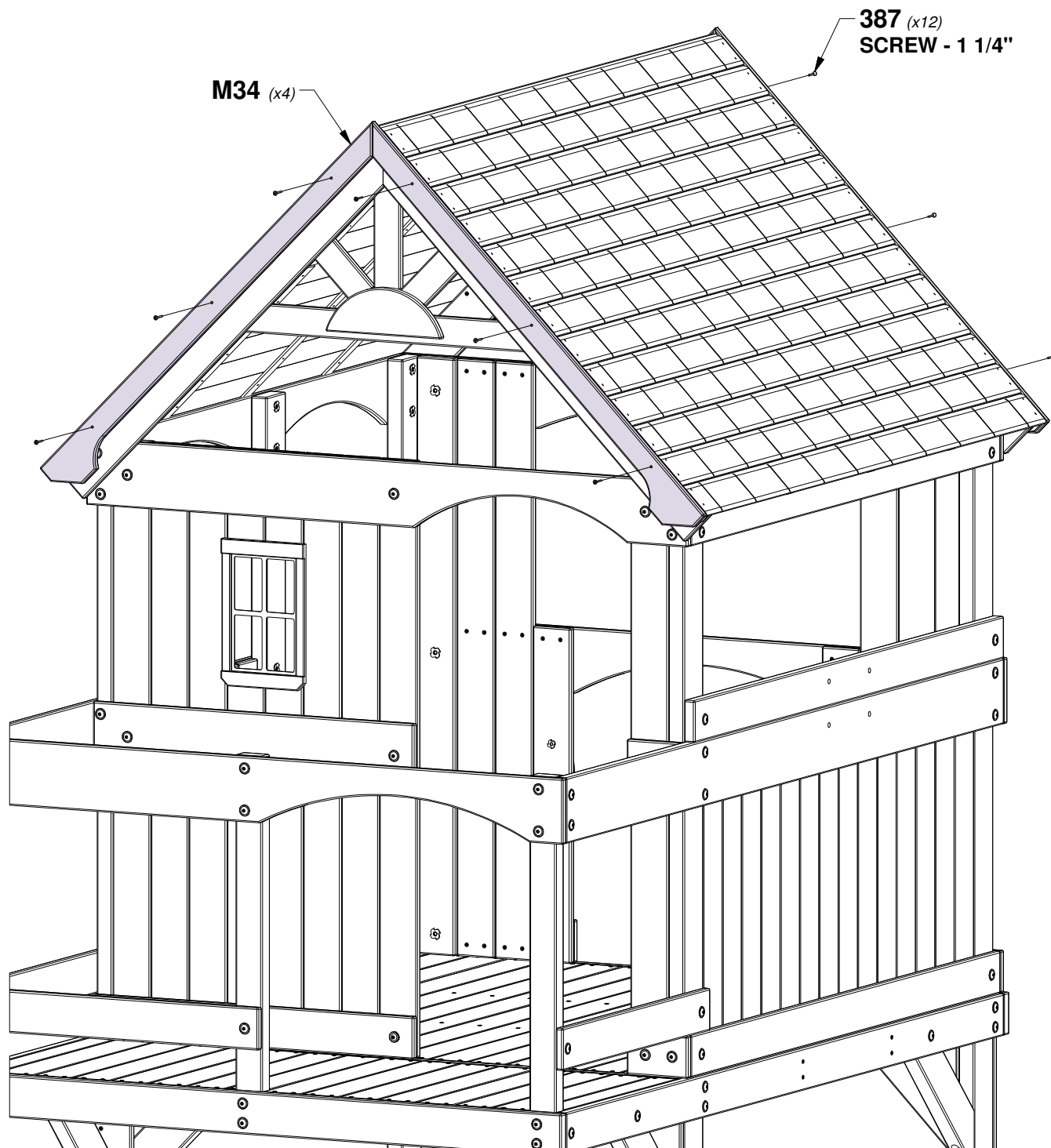

STEP 37 - FORT ASSEMBLY

QTY	PART NUMBER	DESCRIPTION
10	H100088	SCREW PFH 8x1-1/8"

O2 PICKET - W4L06407
(x5) 5/8"x1 3/8"x18 3/4" (16x34x476)

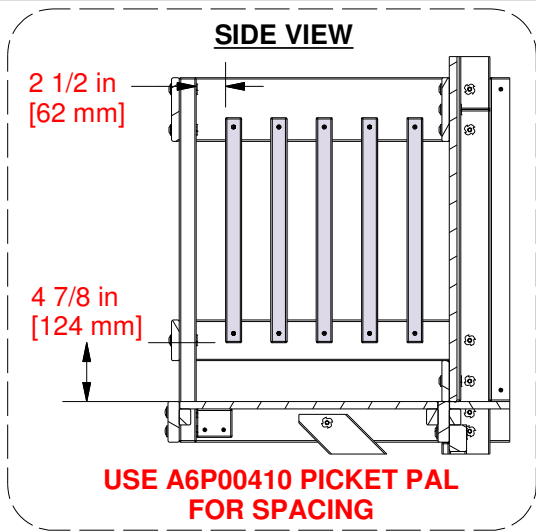

O2 (x5)

088 (x10)
SCREW - 1 1/8"

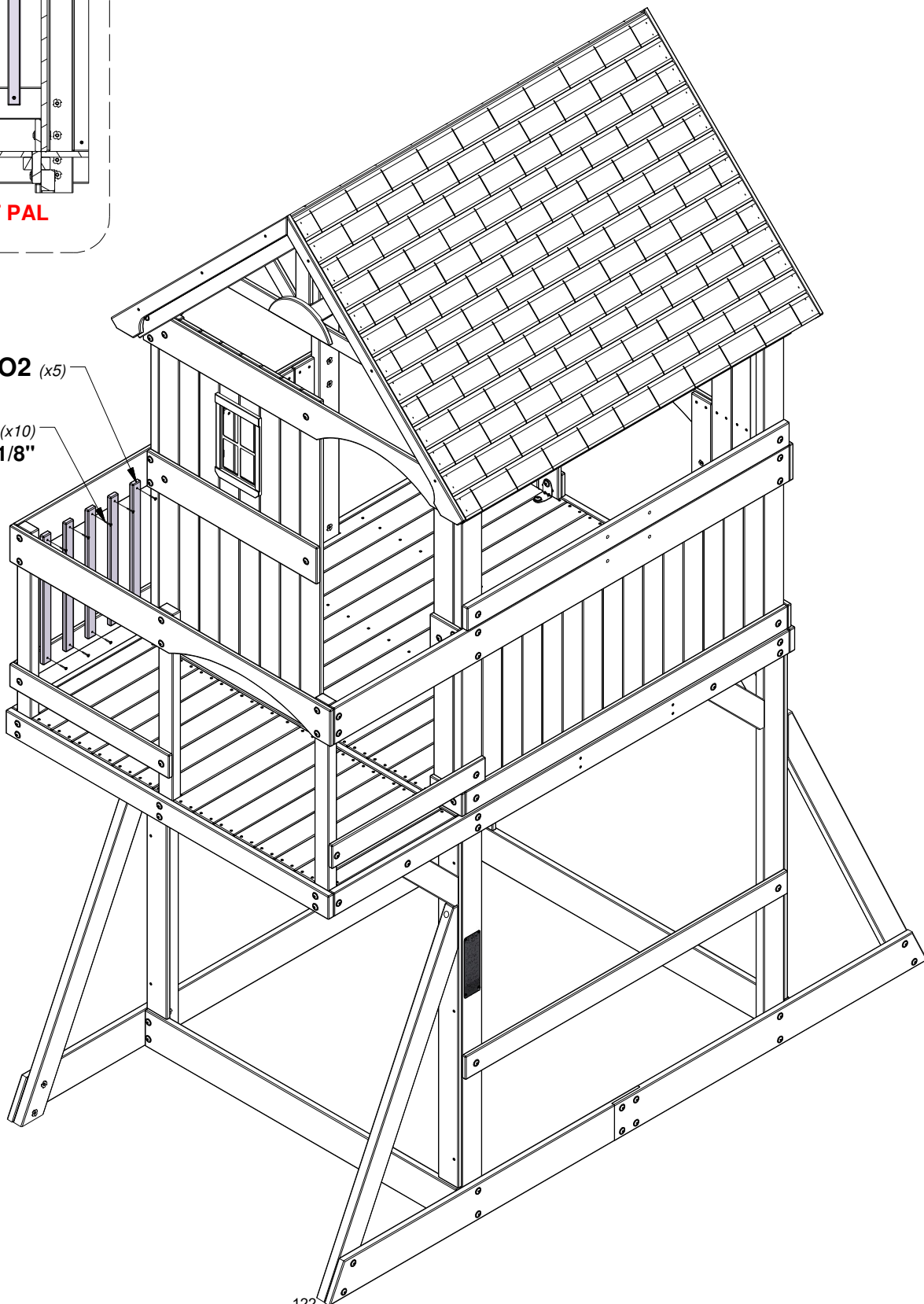

STEP 38 - FORT ASSEMBLY

QTY	PART NUMBER	DESCRIPTION
10	H100088	SCREW PFH 8x1-1/8"

O2 PICKET - W4L06407
(x5) 5/8"x1 3/8"x18 3/4" (16x34x476)

SIDE VIEW

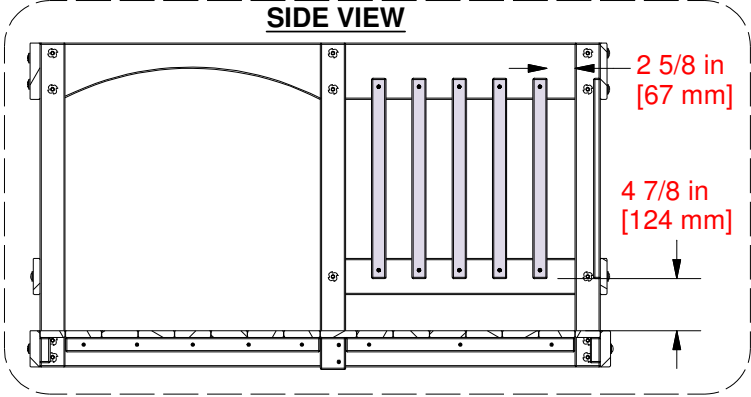

088 (x10)
SCREW - 1 1/8"

O2 (x5)

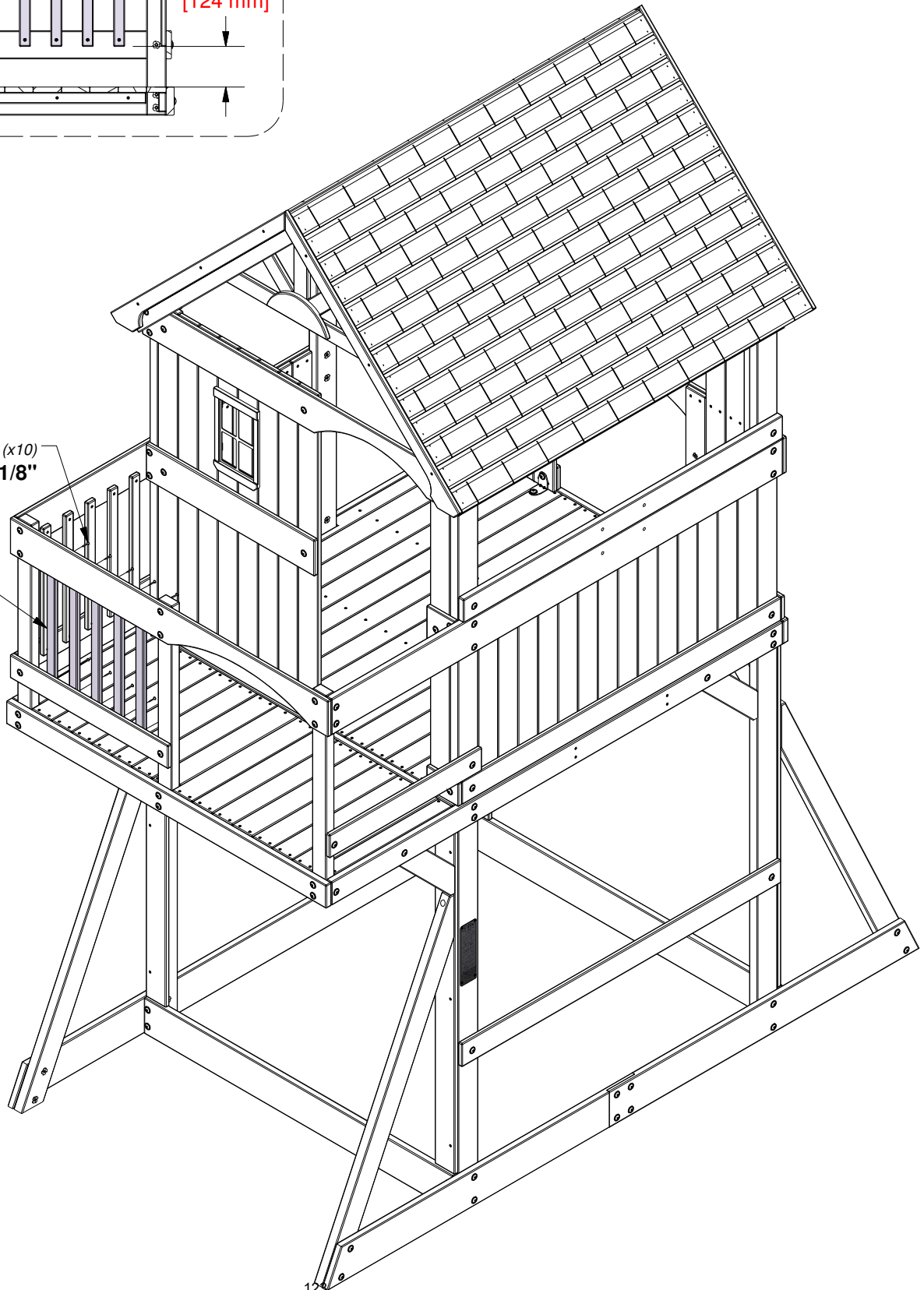

STEP 39 - FORT ASSEMBLY

QTY	PART NUMBER	DESCRIPTION
10	H100088	SCREW PFH 8x1-1/8"

O2 PICKET - W4L06407
(x5) 5/8"x1 3/8"x18 3/4" (16x34x476)

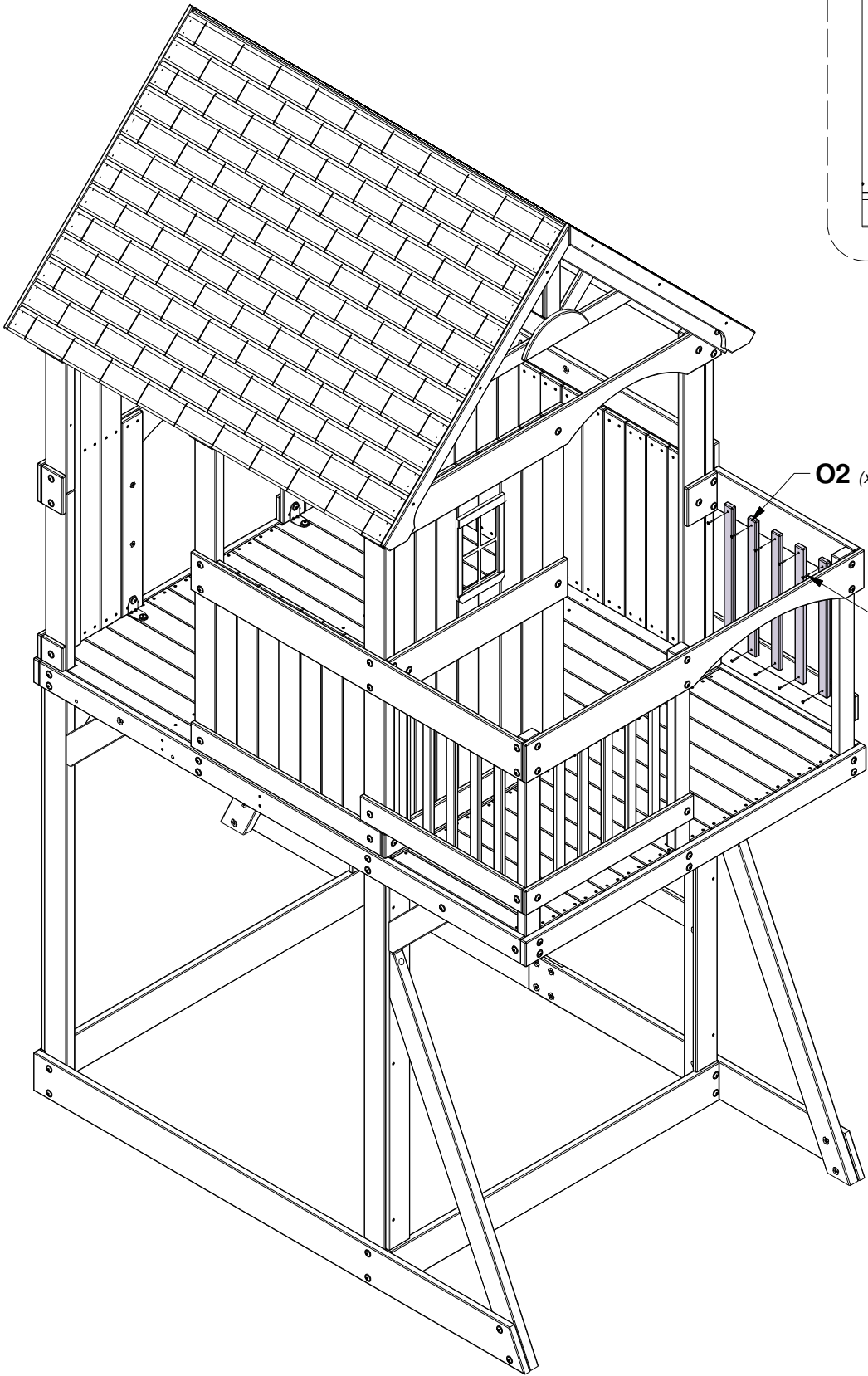
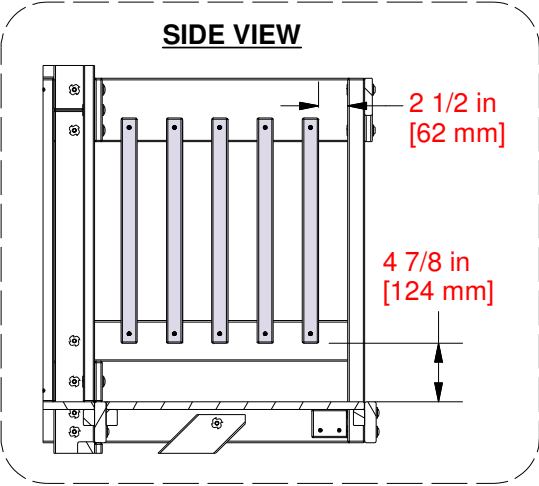

O2 (x5)

088 (x10)
SCREW - 1 1/8"

STEP 40 - FORT ASSEMBLY

QTY	PART NUMBER	DESCRIPTION
4	H100088	SCREW PFH 8x1-1/8"



M1 | **GROWTH BOARD - W4L06143**
(x1) | 5/8"x3 3/8"x60 1/4" (16x86x1530)

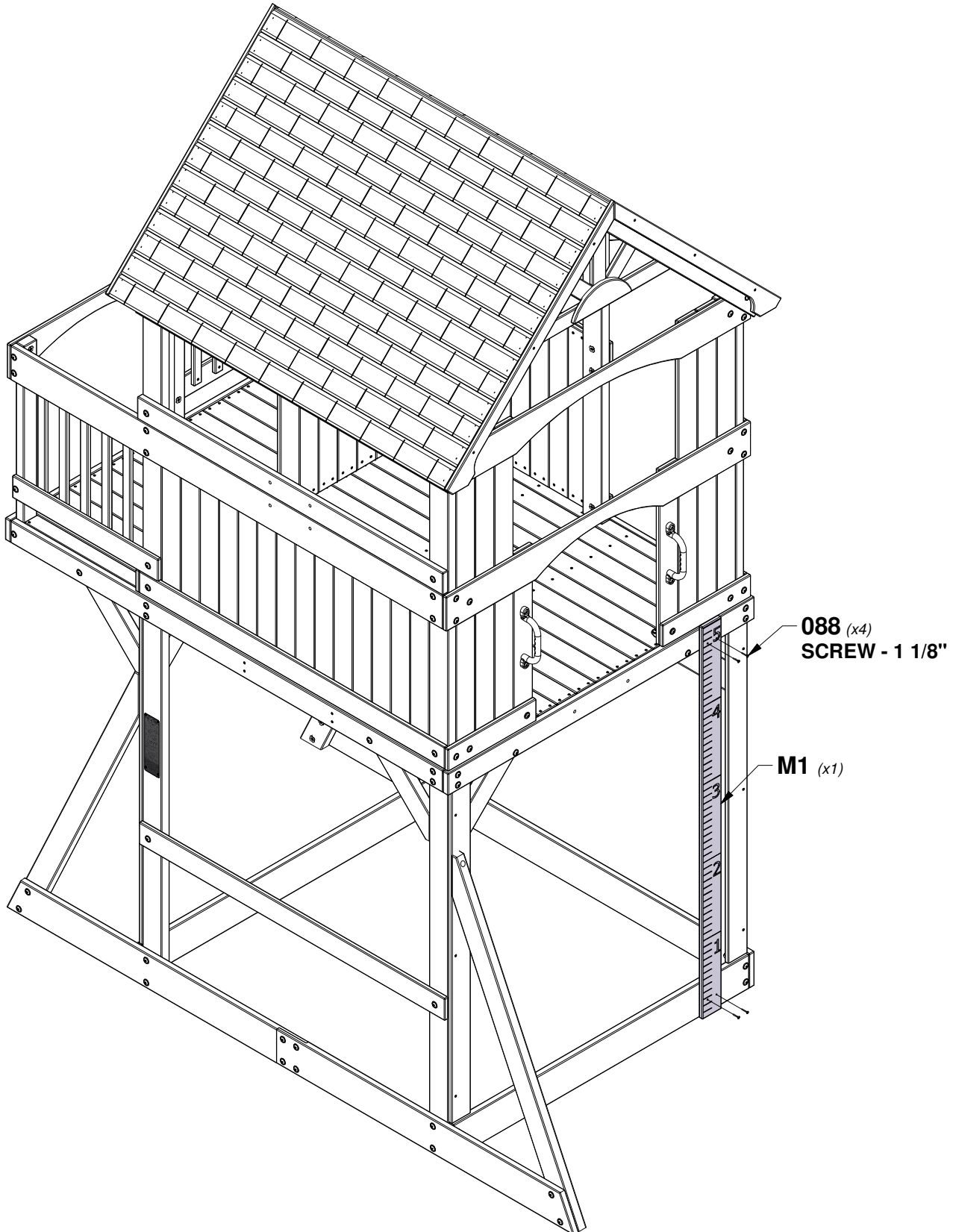

STEP 41 - FORT ASSEMBLY

QTY	PART NUMBER	DESCRIPTION
2	H100198	WASHER LOCK EXT 8x19 BLK
2	H100378	BOLT WH 5/16x1 3/4 BLK
2	H100379	T-NUT 5/16 BLK

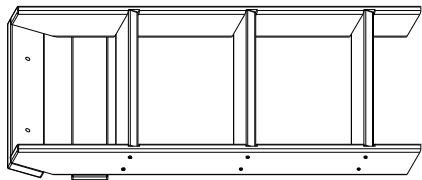

3 FT. LADDER ASSEMBLY

TIP:
INSTALL T-NUTS IN WOOD FIRST

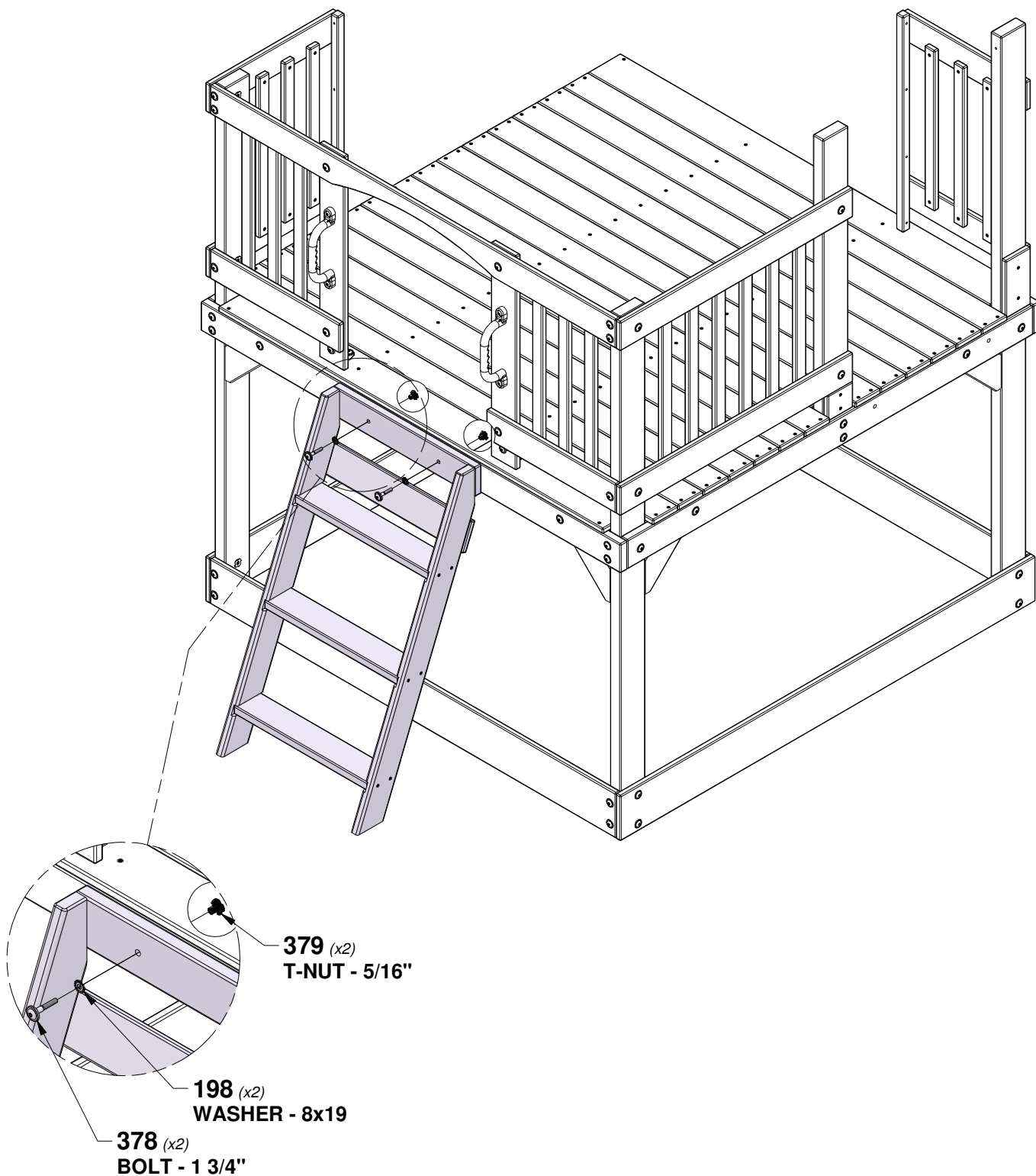

STEP 42 - FORT ASSEMBLY

QTY	PART NUMBER	DESCRIPTION
8	H100089	SCREW PFH 8x1-3/4"
8	H100379	T-NUT 5/16 BLK
8	H100396	BOLT WH 5/16x1/2 BLK

TIP:
INSTALL T-NUTS IN WOOD FIRST

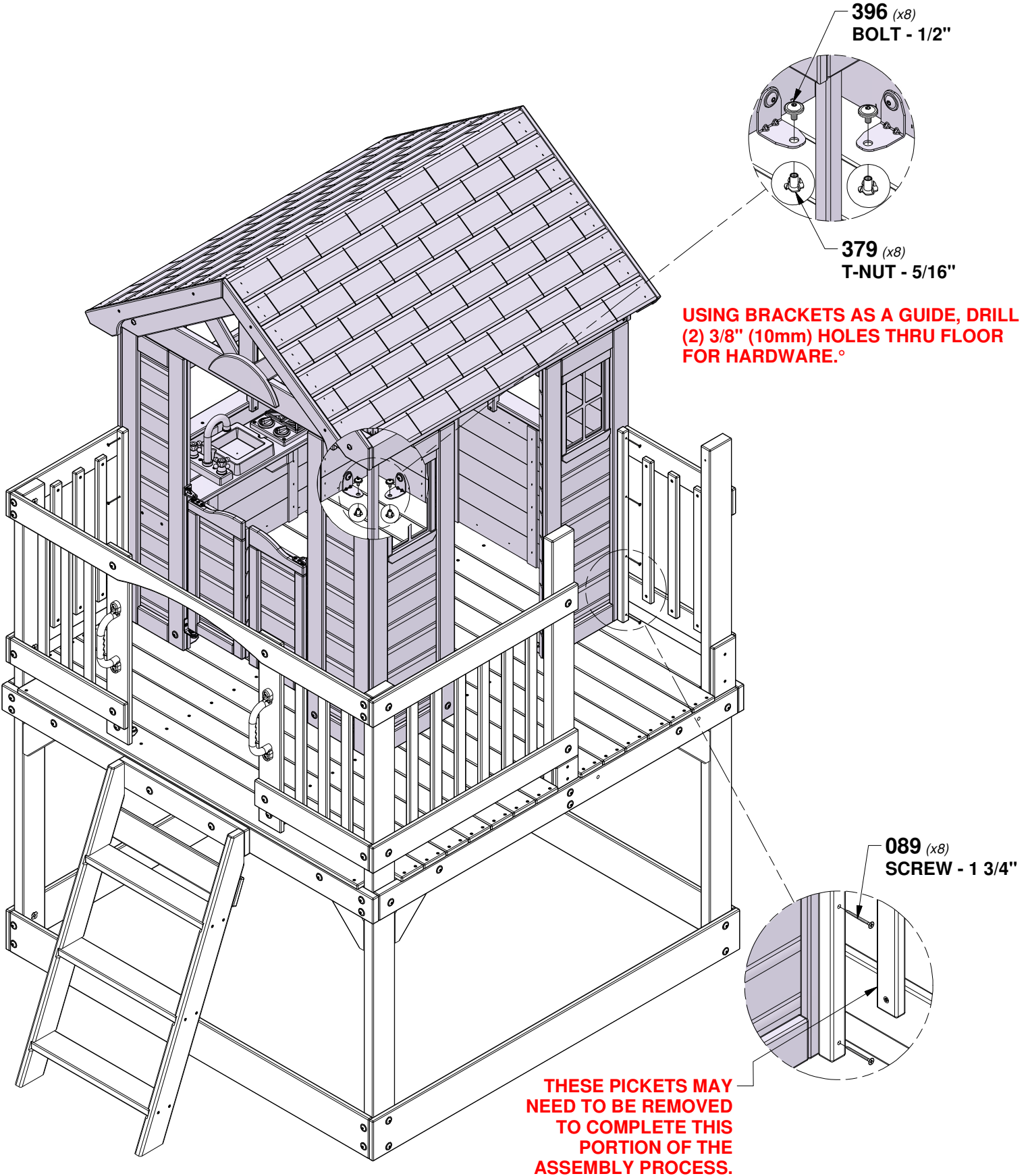

STEP 43 - FORT ASSEMBLY

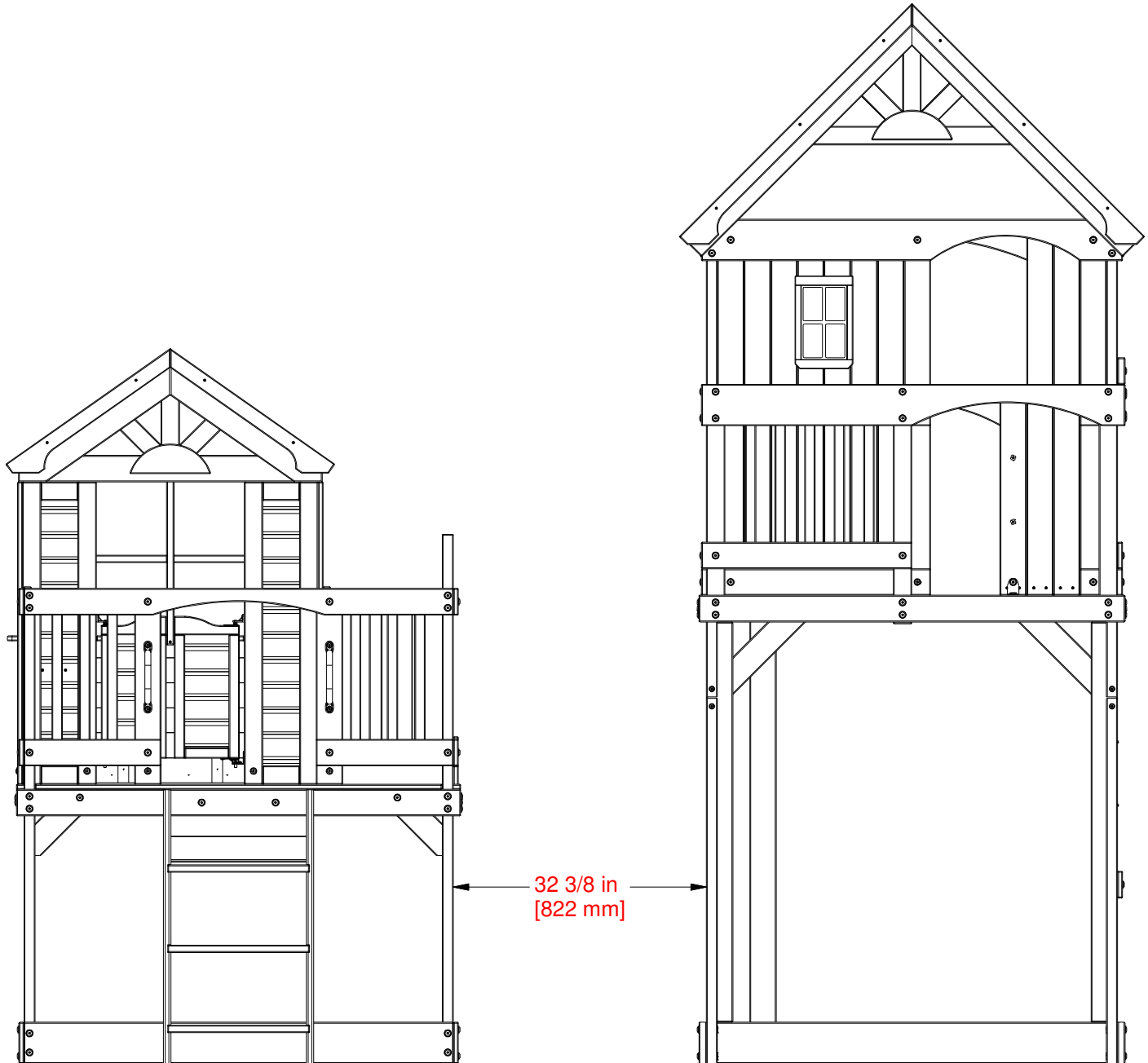

SET FORT AND PLAYHOUSE APPROXIMATELY 32 3/8 in [822 mm] FROM EACH OTHER TO ACCOMMODATE THE STAIRCASE ASSEMBLY.

STEP 44 - FORT ASSEMBLY

QTY	PART NUMBER	DESCRIPTION
4	H100379	T-NUT 5/16 BLK
4	H100468	BOLT WH 5/16x1 BLK

TIP:
INSTALL T-NUTS IN WOOD FIRST

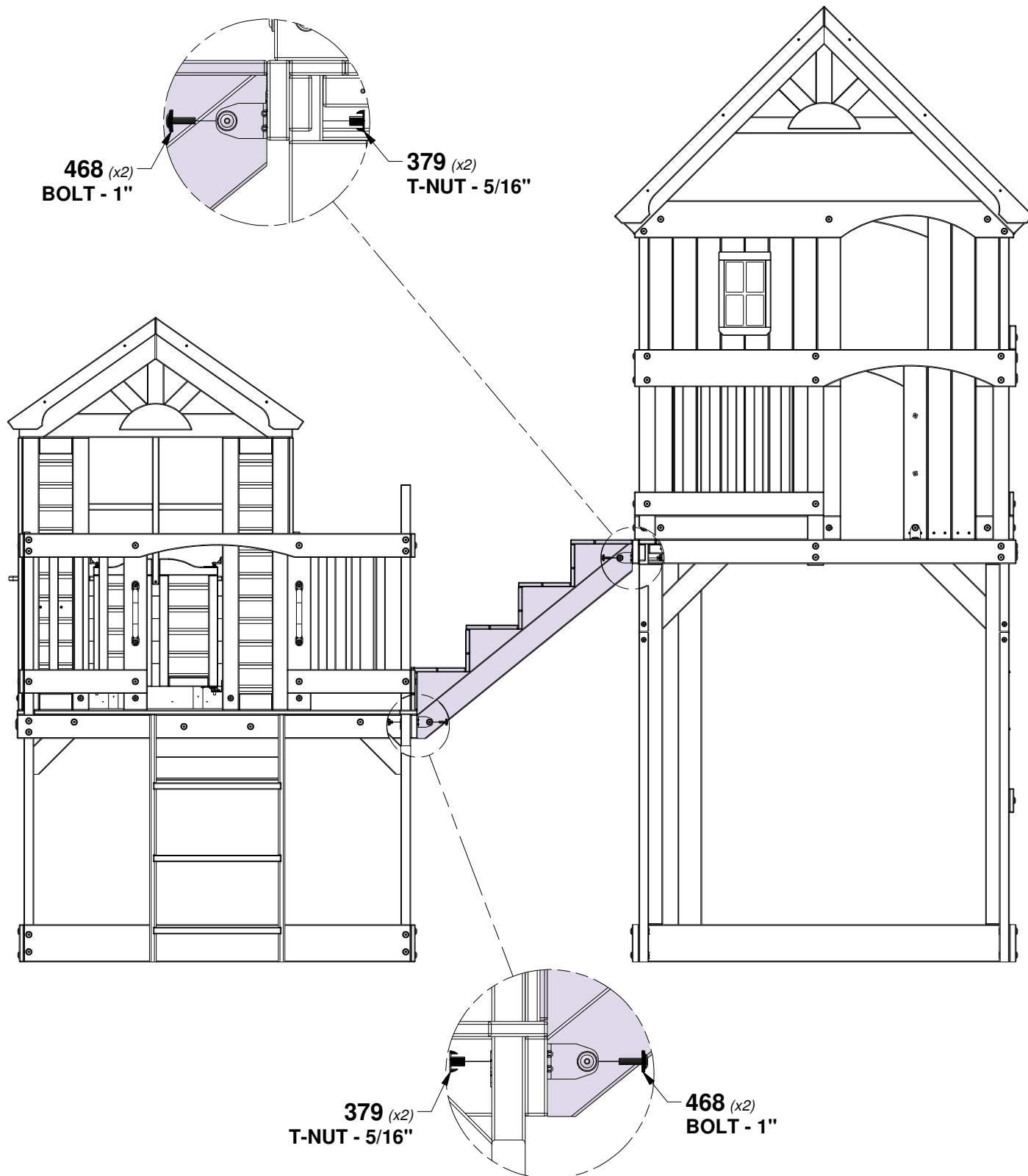

STEP 45 - FORT ASSEMBLY

QTY	PART NUMBER	DESCRIPTION
4	H100198	WASHER LOCK EXT 8x19 BLK
4	H100458	LAG SCREW WH 5/16x2 BLK



H14 | STAIR HAND RAIL - W4L06622
(x2) | 1"x3 3/8"x47 1/2" (24x86x1205)

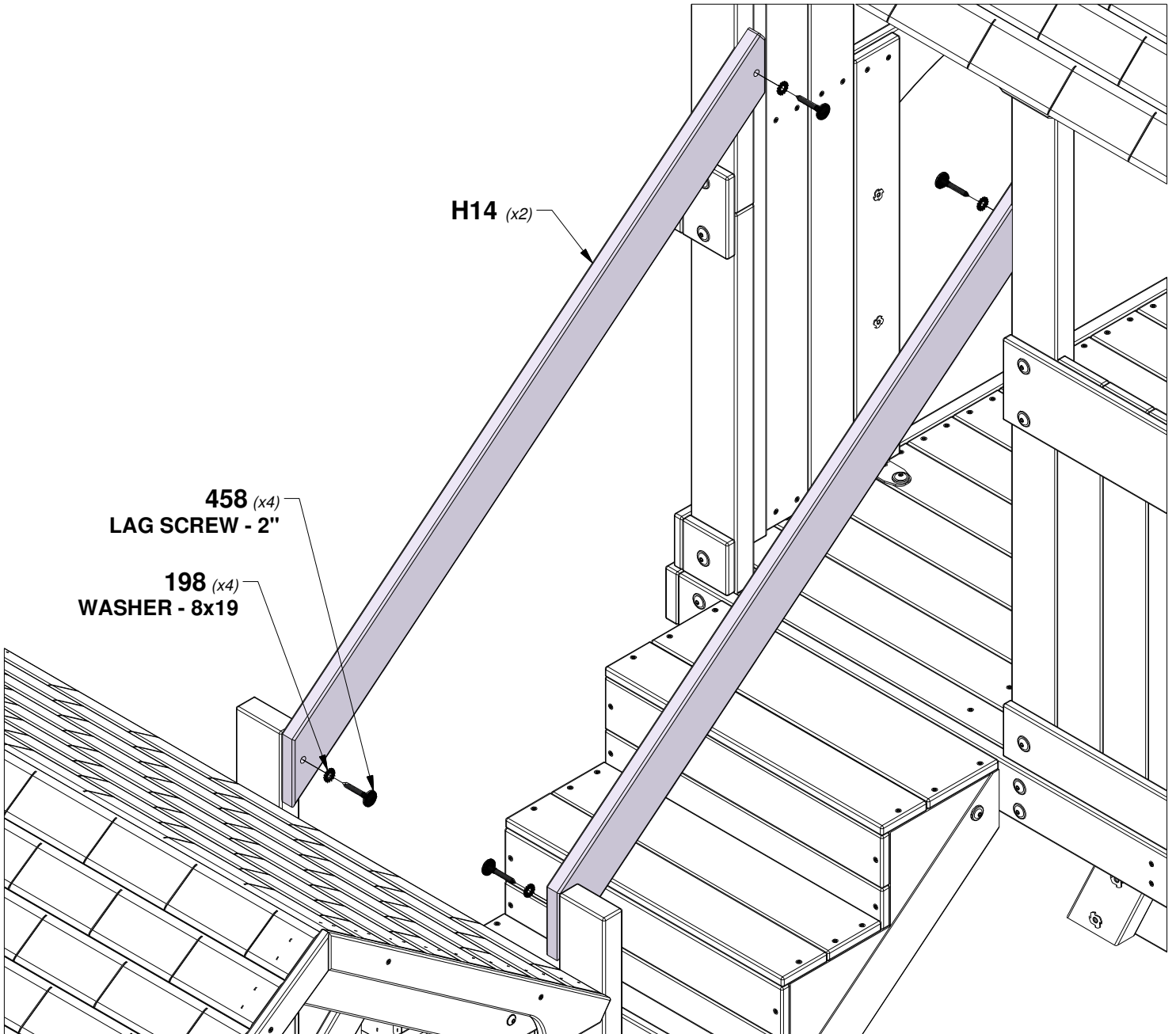

STEP 46 - FORT ASSEMBLY

QTY	PART NUMBER	DESCRIPTION
32	H100087	SCREW PFH 8x1-1/4"



O1 | PICKET - W4L06623
(x16) | 5/8"x1 3/8"x33 1/8" (16x34x840)

TIP:
INSTALL T-NUTS IN WOOD FIRST

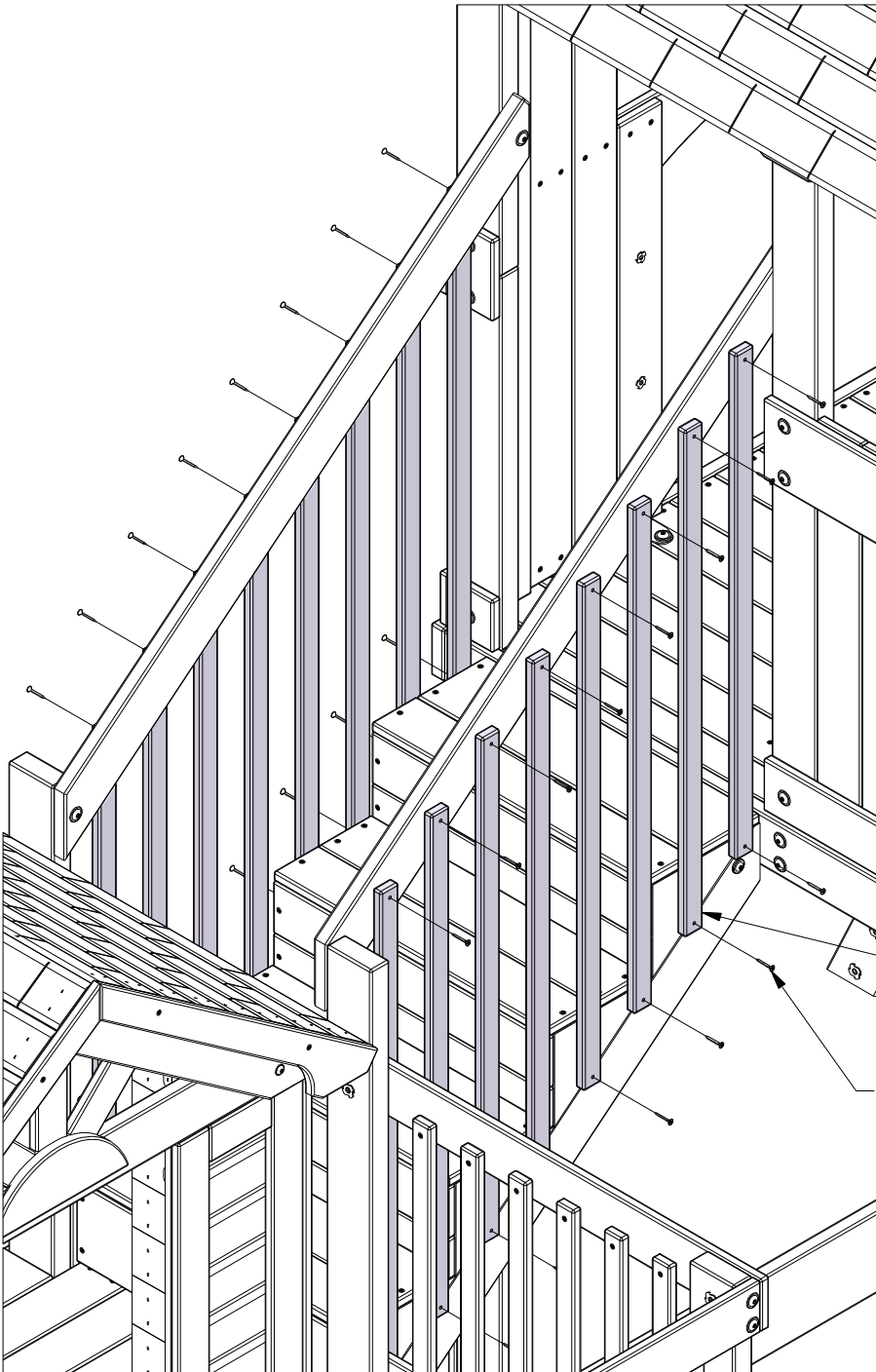
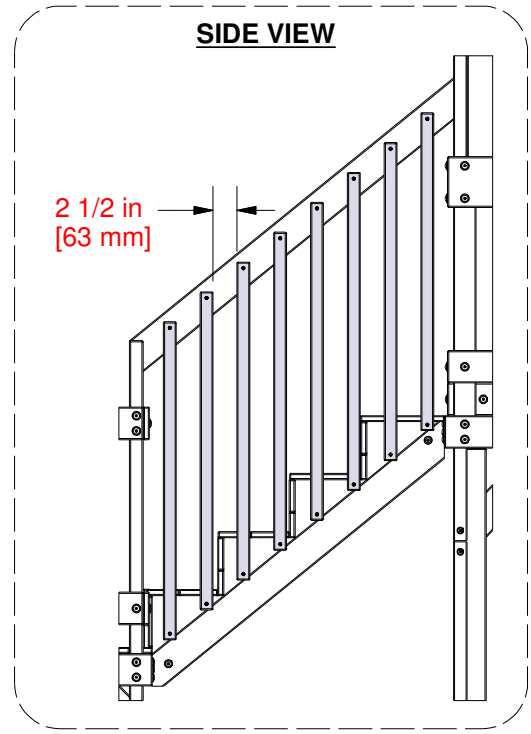

O1 (x16)

087 (x32)
SCREW - 1-1/4"

STEP 47 - FORT ASSEMBLY

QTY	PART NUMBER	DESCRIPTION
2	H100198	WASHER LOCK EXT 8x19 BLK
2	H100407	BOLT WH 5/16x1 1/2 BLK

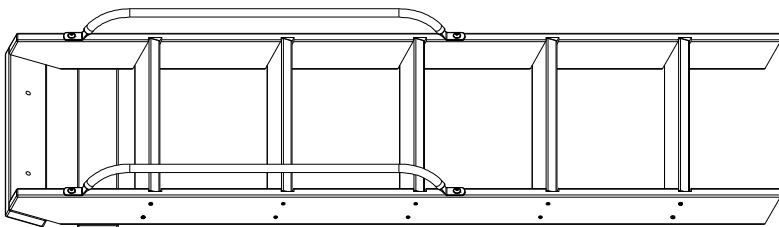

5 FT. LADDER ASSEMBLY

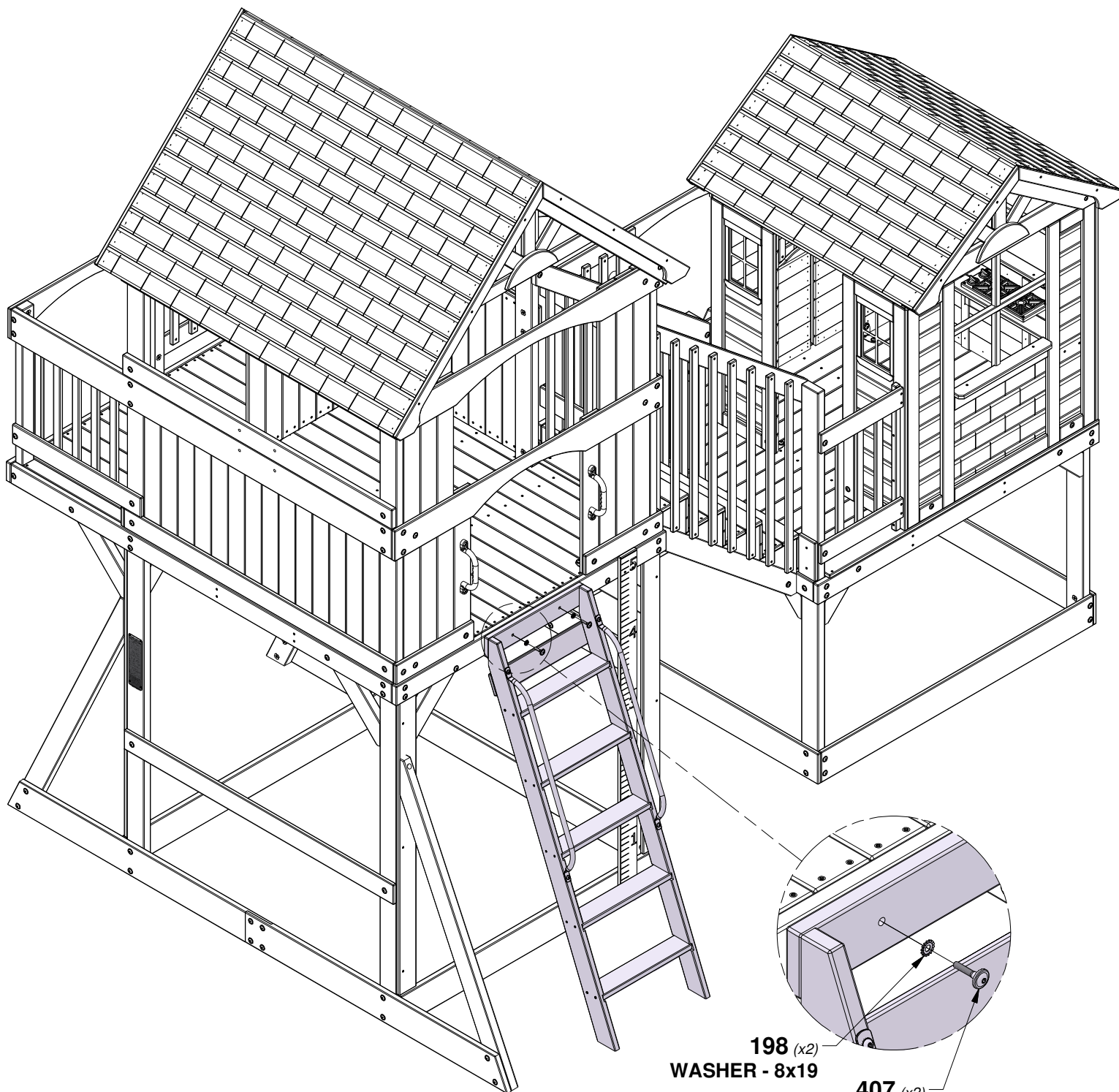

198 (x2)
WASHER - 8x19

407 (x2)
BOLT - 1 1/2"

STEP 1 - SLIDE ASSEMBLY

QTY	PART NUMBER	DESCRIPTION
3	H100074	T-NUT 5/16
3	H100115	BOLT WH 5/16x1/2



A100197
(x1) | **SLIDE BED 10' YELLOW**



M70 | **SLIDE BED SUPPORT - W100935**
(x1) | 5/8"x3 3/8"x19 7/8" (16x86x505)

NOTE:

TAKE NOTE OF SLIDE BED SURFACE FINISH, THE DULL SIDE WILL BE TOWARDS THE GROUND. PLACE SLIDE BRACE CENTERED ON THE BOTTOM (DULL SIDE) AND 1/2" FROM THE EDGE. USE M70 BOARD AS A TEMPLATE FOR DRILLING BOTTOM HOLE PATTERN IN SLIDE BED. USE A 5/16" DRILL BIT.

TOP

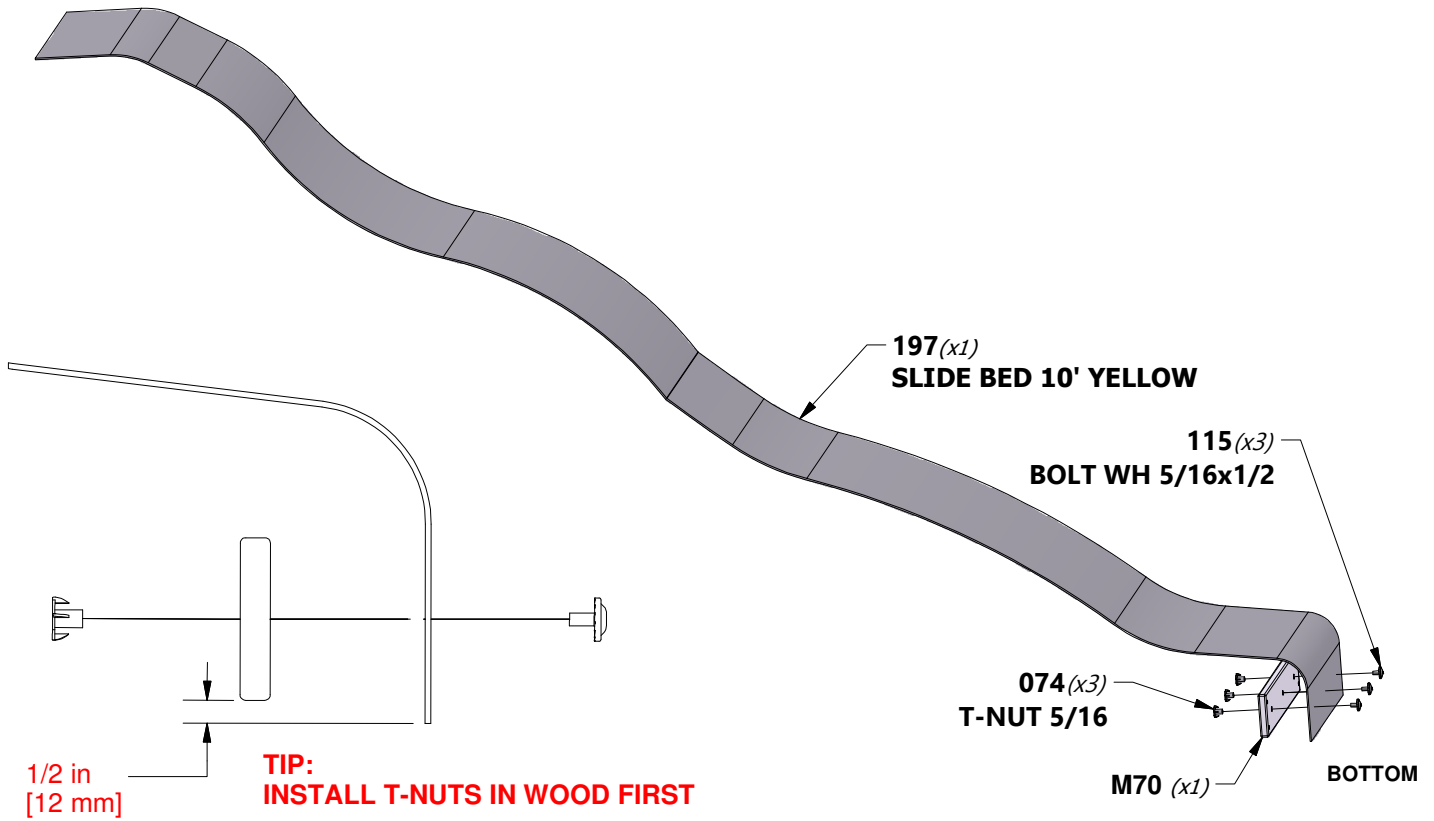

TIP:

PRE-BENDING THE ENDS WILL EASE ASSEMBLY. PLACING THE SLIDE BED OUT IN THE SUN MAKES IT EASIER TO BEND.

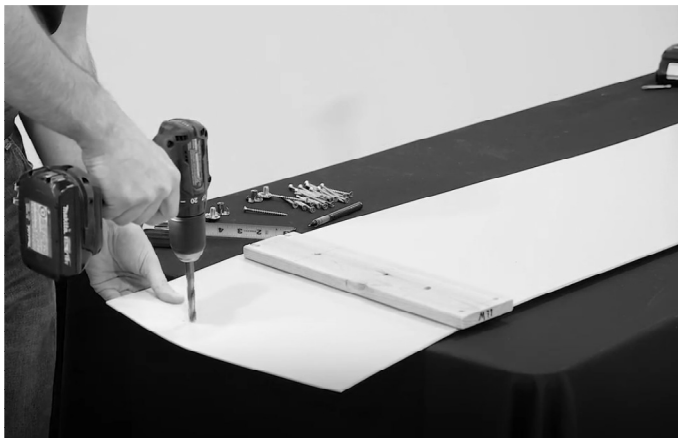

STEP 2 - SLIDE ASSEMBLY

QTY	PART NUMBER	DESCRIPTION
8	H100006	NUT BARREL WH 5/16x1 1/2
8	H100115	BOLT WH 5/16x1/2
6	H100121	SCREW 8x3/4

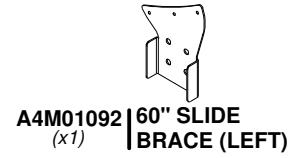
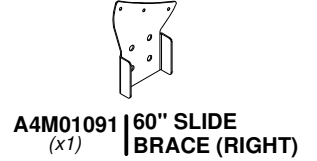
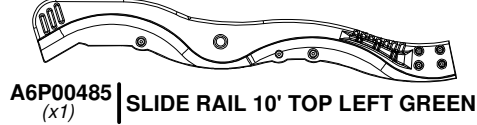
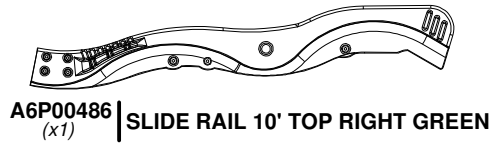
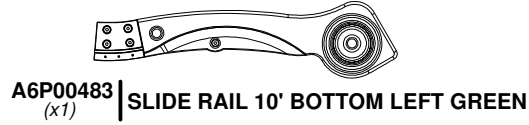

NOTE:
REPEAT ON OTHER SIDE, MAKING
A LEFT AND RIGHT ASSEMBLY.

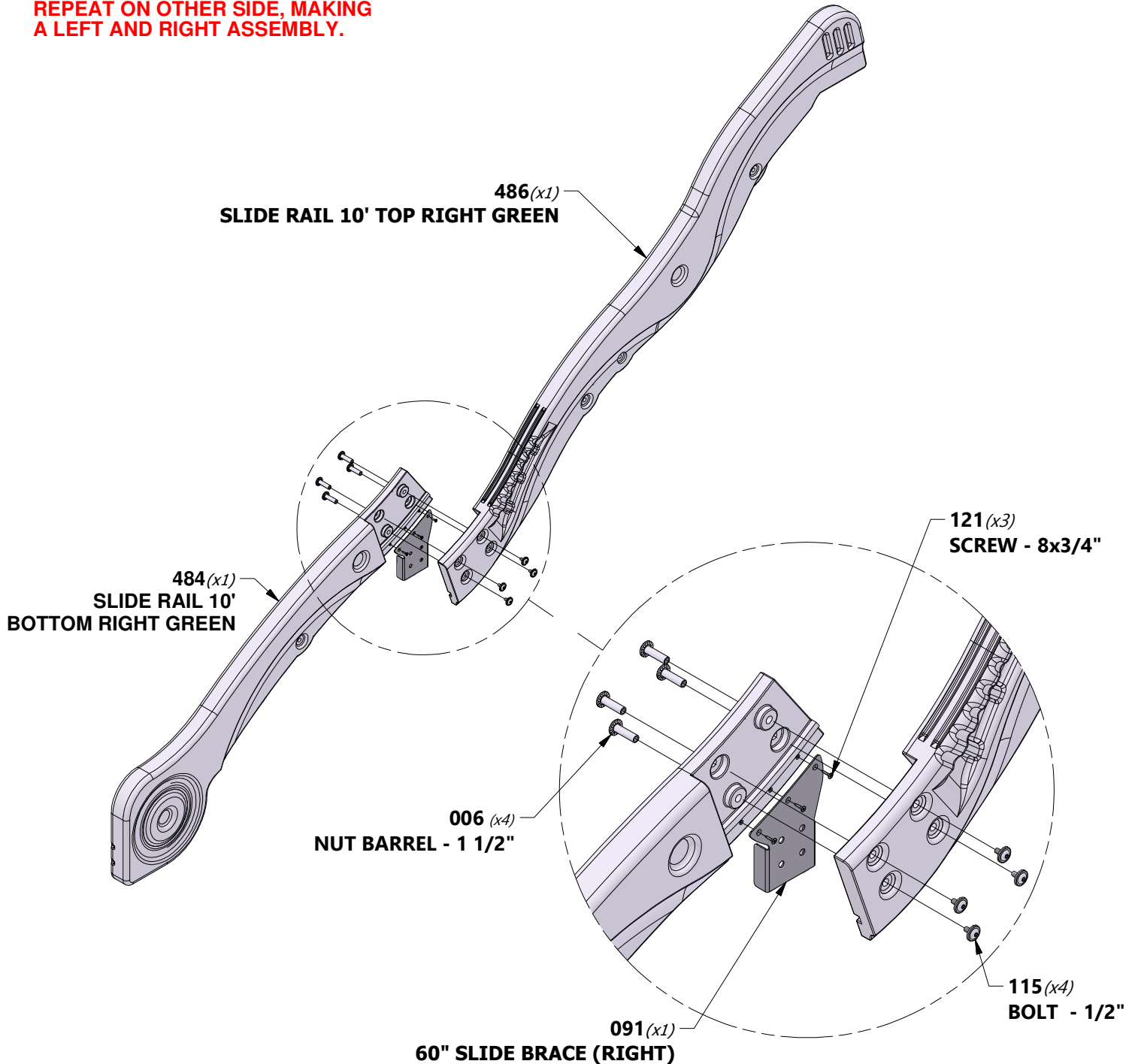

STEP 3 - SLIDE ASSEMBLY

QTY	PART NUMBER	DESCRIPTION
4	H100009	BOLT WH 5/16x1 1/4

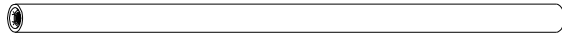

A6P00487
(x4) | SLIDE TUBE SUPPORT

NOTE:
INSERT THE (4) SLIDE SUPPORT TUBES INTO THEIR RESPECTIVE PILOT LOCATIONS (FIGURE 1).

PLACE (1) SLIDE RAIL ASSEMBLY ON A FLAT SURFACE AND BEGIN INSERTING SLIDE BED AT THE BOTTOM OF THE SLIDE RAIL (FIGURE 2). HAVE A HELPER BEND THE SLIDE BED TOWARDS THE TOP OF THE SLIDE AND INSERT THE BED INTO THE SLIDE CAVITY. MAKE SURE SLIDE BED IS INSERTED WITHIN 1/8" (3mm) OF GROOVE BOTTOM.

TIP:
A HELPER IS RECOMMENDED FOR THESE FOLLOWING STEPS.

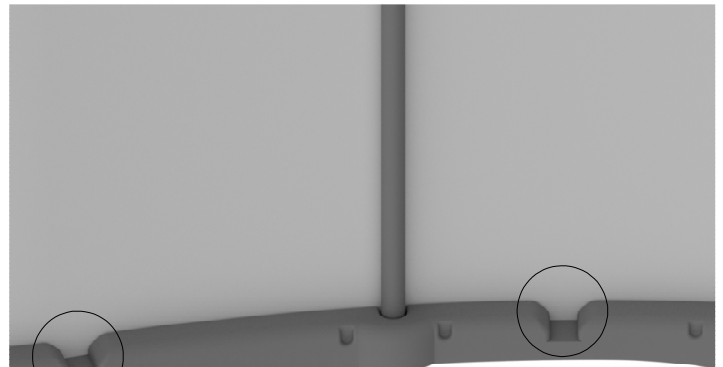
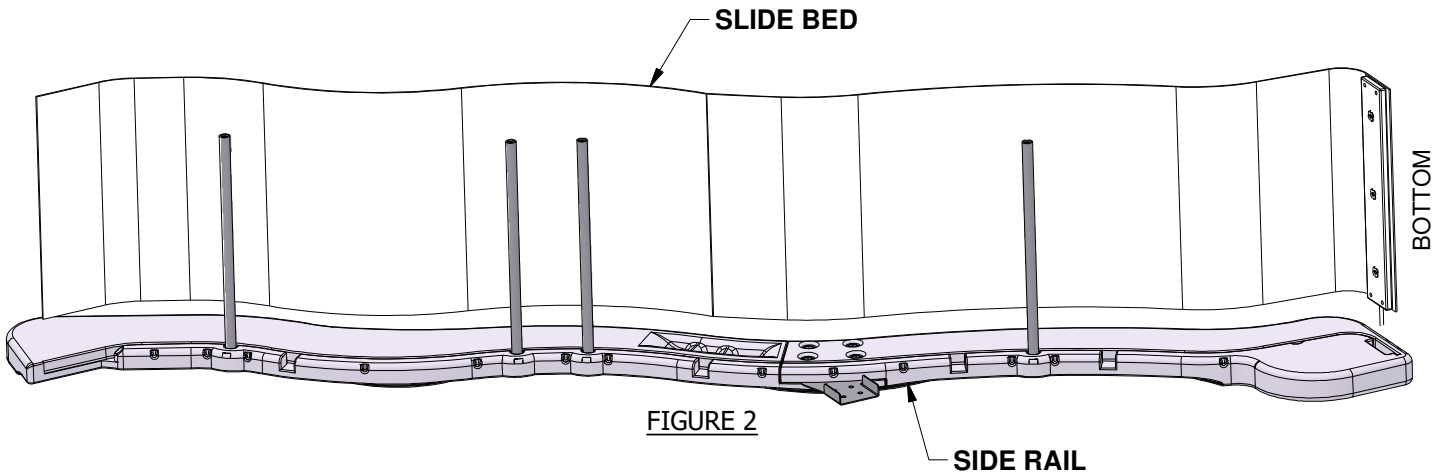
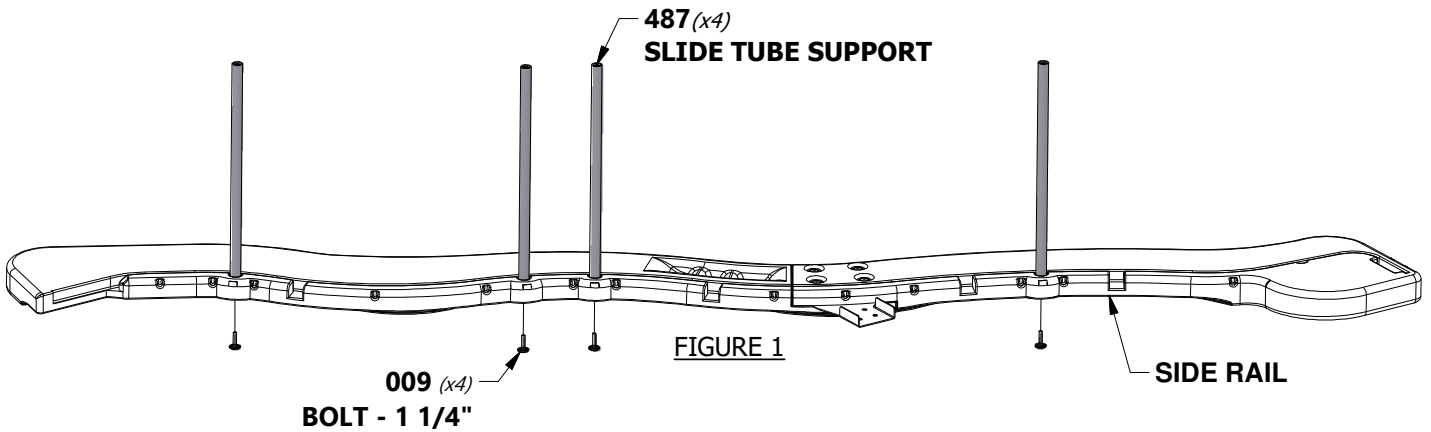

VIEWING WINDOWS

STEP 4 - SLIDE ASSEMBLY

NOTE:
PLACE SECOND SLIDE RAIL ASSEMBLY OVER THE TOP OF THE SLIDE BED AND SLIDE SUPPORT TUBES. INSERT THE SLIDE BED AND SLIDE SUPPORT TUBES INTO THE SLIDE CAVITY. MAKE SURE SLIDE BED IS INSERTED WITHIN 1/8" (3mm) OF GROOVE BOTTOM.



FAILURE TO INSERT SLIDE BED PROPERLY MAY RESULT IN INJURY OR AMPUTATION. EXPOSED SLIDE EDGES CAN BE SHARP AND BECOME A LACERATION HAZARD IF THE SLIDE IS NOT PROPERLY ASSEMBLED.

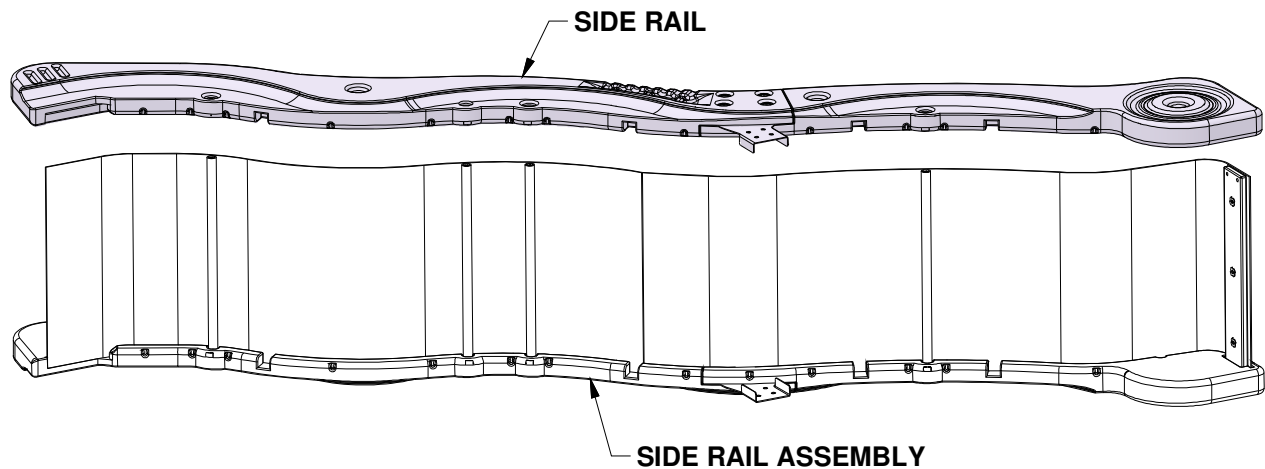

TIP:
USE A RUBBER Mallet TO FULLY SEAT THE SLIDE BED INTO THE SLIDE CAVITY.

STEP 5 - SLIDE ASSEMBLY

QTY	PART NUMBER	DESCRIPTION
4	H100009	BOLT WH 5/16x1 1/4

NOTE:
USE 1 1/4" BOLTS TO FASTEN EACH
SIDE OF THE SLIDE SUPPORT TUBES.

TIP:
HAVING A HELPER HOLD THE SLIDE
ASSEMBLY TOGETHER WHILE YOU FASTEN
WILL MAKE IT EASIER TO ASSEMBLE.

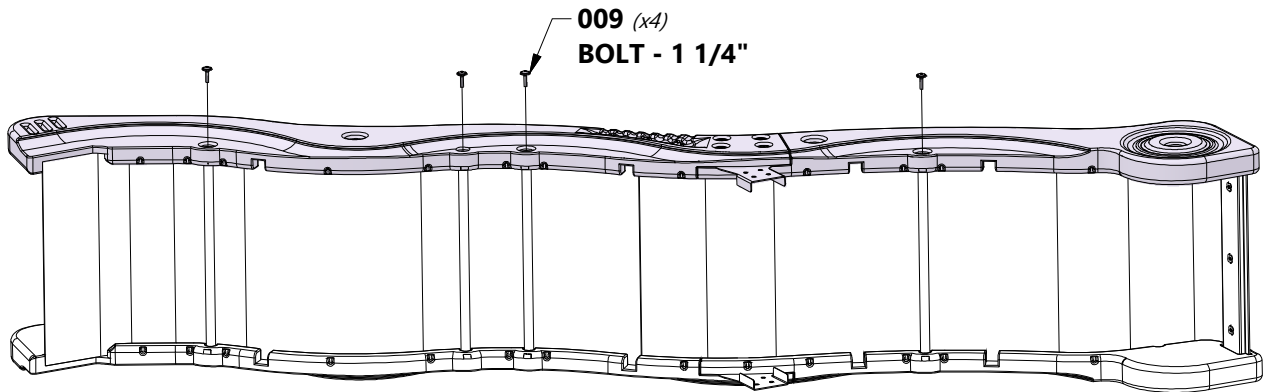

STEP 6 - SLIDE ASSEMBLY

QTY	PART NUMBER	DESCRIPTION
30	H100090	SCREW PFH 8x2 1/2

NOTE:
USING AN 1/8" DRILL BIT, DRILL PILOT HOLES IN EACH INDENTATION ALONG EACH SIDE RAIL. THERE SHOULD BE 15 INDENTATIONS ON EACH RAIL. BE SURE TO DRILL THROUGH THE SLIDE RAIL AND THE SLIDE BED. THEN SECURE WITH THE PROVIDED HARDWARE.

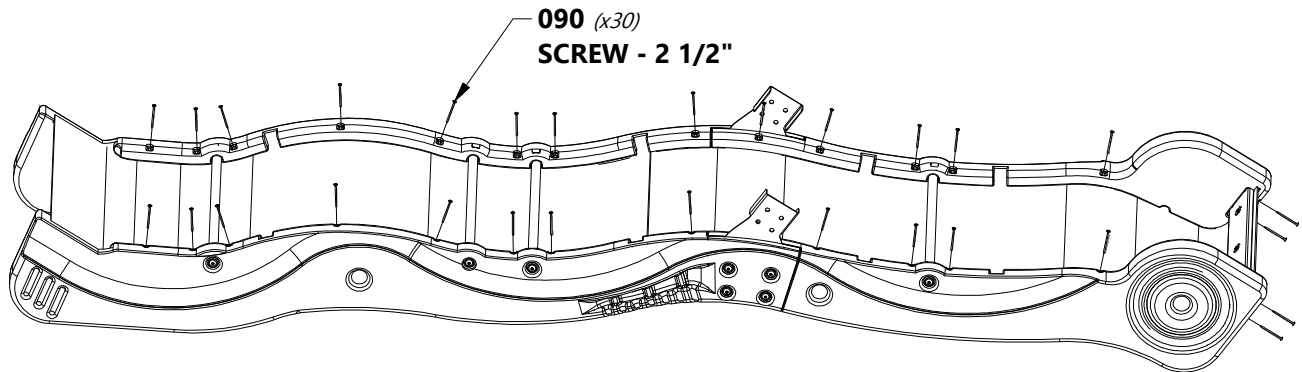

STEP 7 - SLIDE ASSEMBLY

QTY	PART NUMBER	DESCRIPTION
8	H100008	BOLT WH 5/16x1
8	H100074	T-NUT 5/16
4	H100111	SCREW PFH 8x2



H80 | SLIDE BRACE WIDE - W4L15715
(x1) | 1"x3 3/8"x18 3/8" (24x86x466)



H81 | SLIDE BRACE UPRIGHT - W4L13301
(x2) | 1"x3 3/8"x22 7/8" (24x86x580)

TIP:
INSTALL T-NUTS IN WOOD FIRST

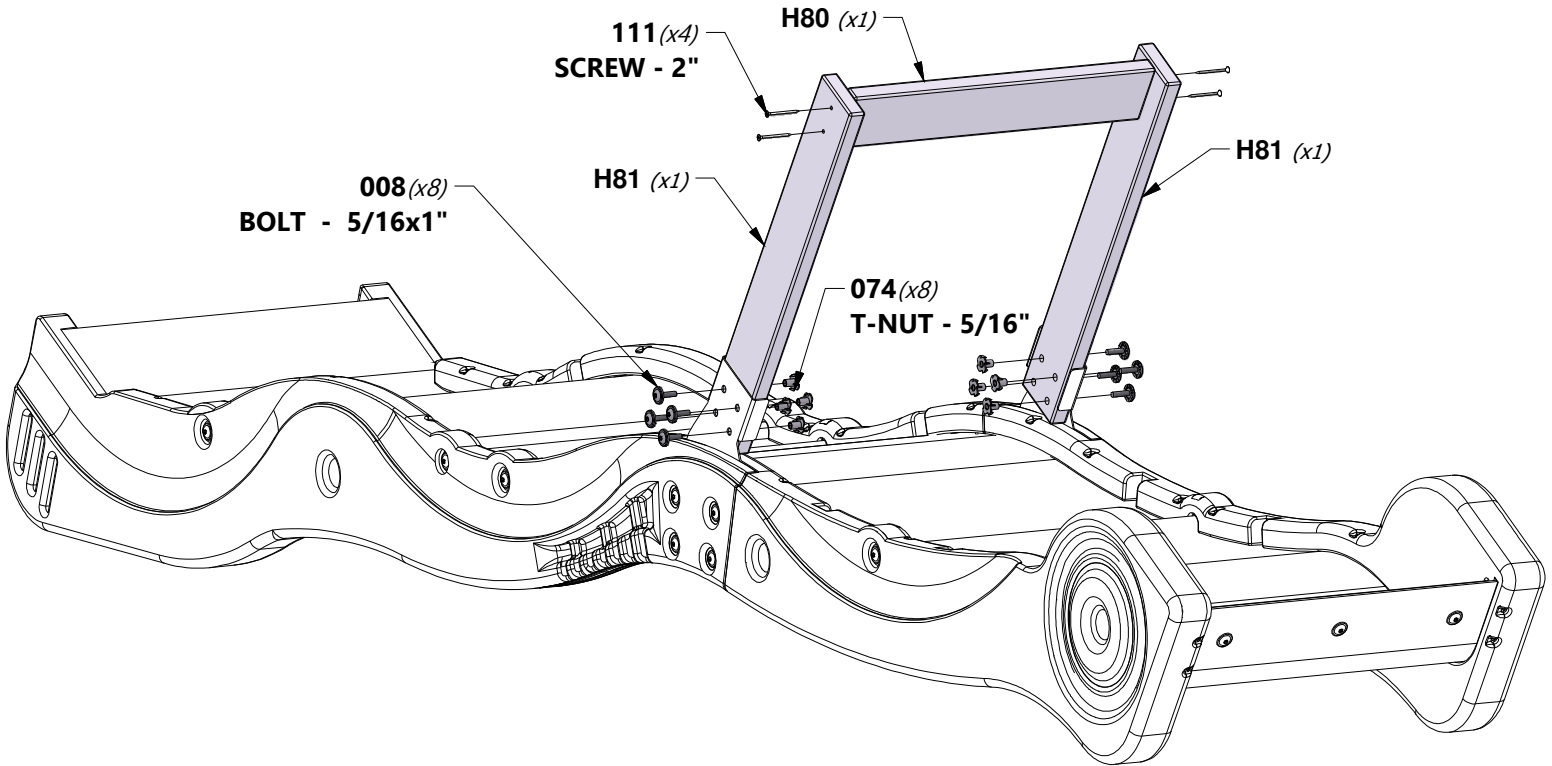

STEP 48 - FORT ASSEMBLY

QTY	PART NUMBER	DESCRIPTION
3	H100074	T-NUT 5/16
3	H100115	BOLT WH 5/16x1/2

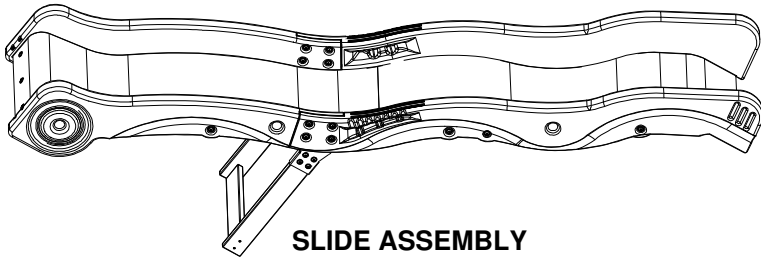

SLIDE ASSEMBLY

TIP:
INSTALL T-NUTS IN WOOD FIRST

TOP VIEW

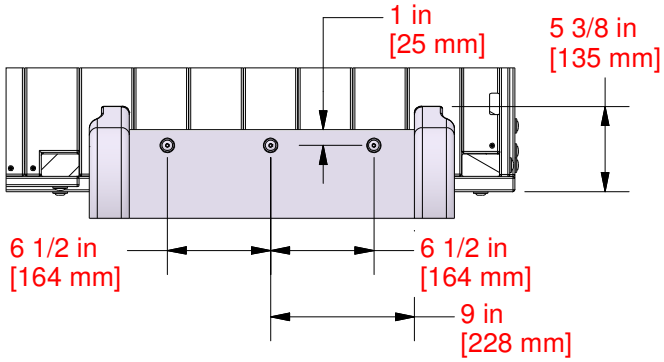

NOTE:
CENTER SLIDE IN OPENING. USING DIMENSIONS ABOVE AS A TEMPLATE, DRILL (3) 3/8" [10mm] HOLES THROUGH DECK FOR HARDWARE.

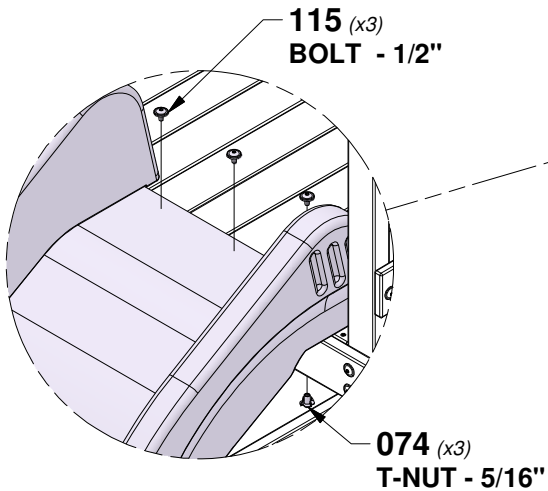
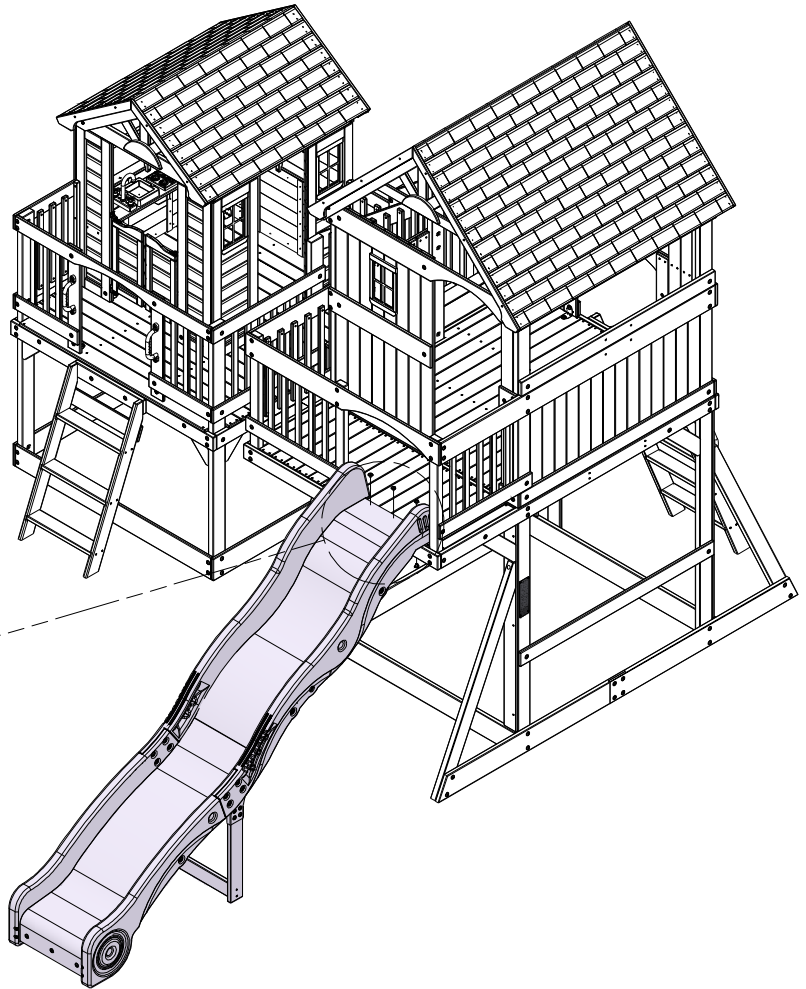

STEP 49 - FORT ASSEMBLY

QTY	PART NUMBER	DESCRIPTION
4	H100477	WASHER SPLIT 5/16 BLK
4	H100478	WASHER FLAT 8x27 BLK
4	H100481	BOLT HEX 5/16x1 1/4 BLK

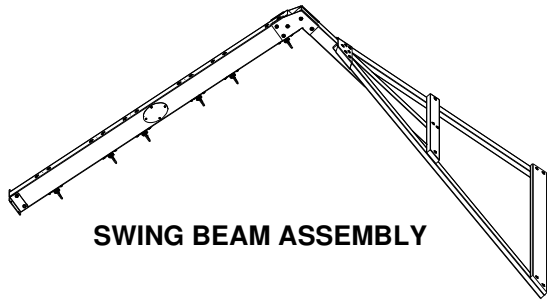

SWING BEAM ASSEMBLY

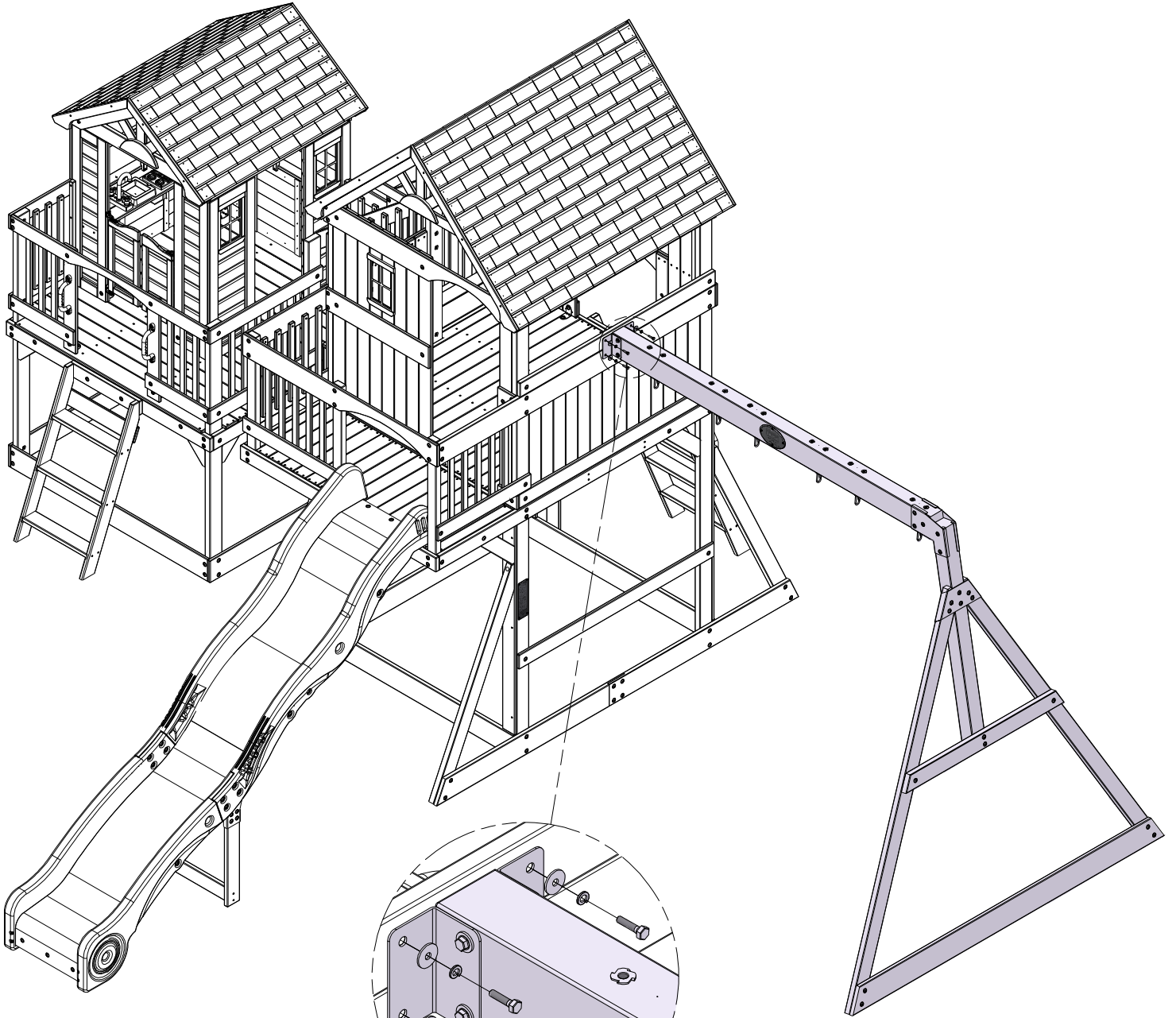

478 (x4)
WASHER - 8x27

477 (x4)
WASHER - 5/16

481 (x4)
BOLT - 1 1/4"

STEP 50 - FORT ASSEMBLY

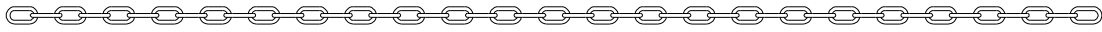

A100047 | CHAIN GREEN 57"
(x4)



A100177 | CHAIN GREEN 31"
(x2)

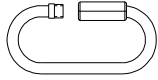

A100069 | QUICK LINK
(x6)

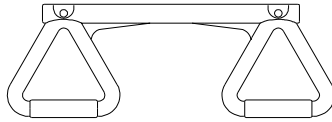

A6P00034 | TRAPEZE YELLOW
(x1)

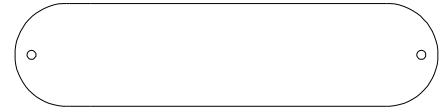

A6P00054 | SWING SEAT GREEN 22"
(x2)

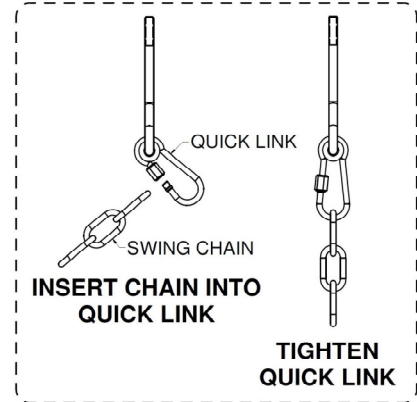
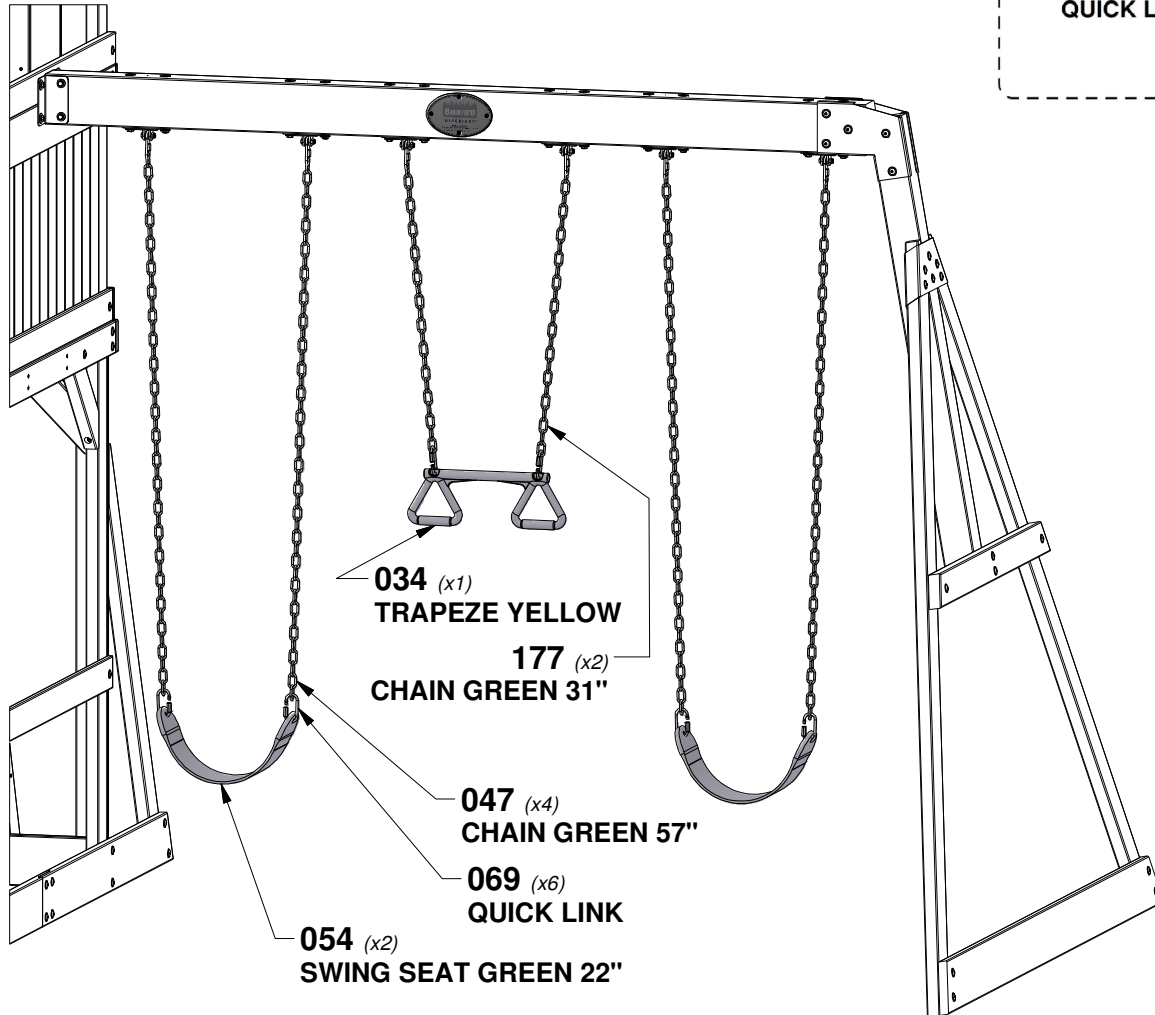

STEP 51 - FORT ASSEMBLY

QTY	PART NUMBER	DESCRIPTION
8	H100379	T-NUT 5/16 BLK
6	H100459	BOLT WH 5/16x1 1/4 BLK
2	H100468	BOLT WH 5/16x1 BLK



A100178
(x8) | AUGER GROUND STAKE

TIP:
INSTALL T-NUTS IN WOOD FIRST

TWIST GROUND STAKE INTO GROUND AT LOCATIONS SHOWN. USING AUGER STAKE AS A GUIDE, DRILL A 7/16" [10mm] HOLE FOR HARDWARE.

