

SECTION A-A

6 Threads Per Inch
.167 Lead 1 1/8 turns

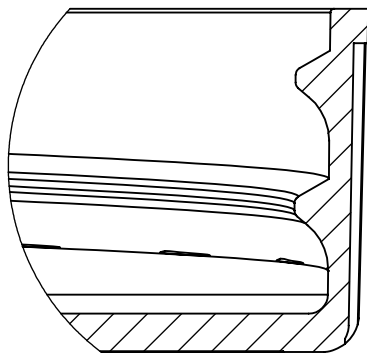
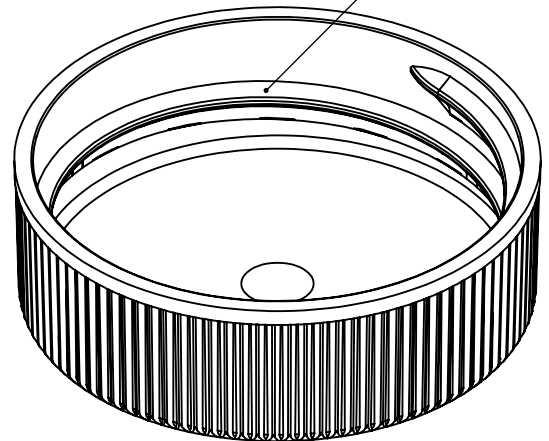

DETAIL B
SCALE 4 : 1

MATERIAL

Polypropylene

DISTRIBUTED BY:



REF NO.:

DWG31522

DISCLAIMER
THIS INFORMATION IS PROVIDED AS A GENERAL GUIDE, INCLUDING DIMENSIONS. IT IS THE CUSTOMER'S RESPONSIBILITIES TO SELECT THE PROPER CONTAINER FOR PRODUCT AND APPLICATION COMPATIBILITY.

DESCRIPTION:

33 mm 33-400 Black PP Plastic Matte Top, Ribbed Side Cap, Foam Liner

PRODUCT DATASHEET

F-217
NA

- F-217 is a three-layer coextruded primary liner consisting of two solid low-density polyethylene (LDPE) surfaces with a closed-cell foamed low-density polyethylene (LDPE) core
- The foamed core provides compression and resilience to provide gasket functionality and the solid surfaces provide a smooth surface for maximum leak resistance and barrier
- Does not promote microbial growth

Construction¹

<p>Thickness SI (µm)</p> <p>Standard Thicknesses 508 – 3175 in 127 µm increments</p>		<p>Thickness US (Mils)</p> <p>Standard Thicknesses 20 -125 in 5 mil increments</p>
--	--	--

Properties

Characteristic	SI	US
Color	White	White
Appearance	Opaque	Opaque
Density		
508-760 µm 20-30 mil	480 ± 30 kg/m ³	30 ± 2 lb./ft ³
890-3175 µm 35-125 mil	400 ± 30 kg/m ³	25 ± 2 lb./ft ³
Thickness Tolerance		
508-1524 µm 20-60 mil	± 178 µm	± 5 mil
1650-2290 µm 65-90 mil	± 178 µm	± 7 mil
2410-3180 µm 95-125 mil	± 254 µm	± 10 mil
Durometer ² Shore A, O"	60	60
Compression Set ² 23°C, 25%, 22h	39	39
Available Widths		
508 – 1520 µm 20 – 60 mil	25,4 – 1016,0 mm	1.0 – 40.0 in
1650 – 3180 µm 65 – 125 mil	25 – 228 mm	1 – 9 in
Width Tolerance	± 1,6 mm	± 0.0625 in

Product Attributes

- Mechanically strong and stable
- Excellent chemical resistance
- Good compressibility
- Coextruded, not laminated, no adhesive
- Resists discoloration
- Good machinability
- Does not promote microbial growth
- No absorption
- Ideal application and removal torque
- No dusting: foam particles cannot come loose
- Non-toxic and free of odors and taste
- Cost efficient

Page 2 of 2

DISTRIBUTED BY:



REF NO.:

DWG31522

DISCLAIMER
THIS INFORMATION IS PROVIDED AS A GENERAL GUIDE, INCLUDING DIMENSIONS. IT IS THE CUSTOMER'S RESPONSIBILITIES TO SELECT THE PROPER CONTAINER FOR PRODUCT AND APPLICATION COMPATIBILITY.

DESCRIPTION:

33 mm 33-400 Black PP Plastic Matte Top, Ribbed Side Cap, Foam Liner