



BEST CHOICE
PRODUCTS



INSTRUCTION MANUAL

Folding Sewing Craft Table

SKY6515 + SKY7178 + SKY7179 + SKY7526 + SKY7527 + SKY7528
SKY7529

! NOTICE

Please retain these instructions for future reference.

- Please do not exceed the weight limitations of this item.
- Do not stand on or use any part of this item as a step ladder.
- Firmly secure all bolts, screws, and knobs before use.
- Reconfirm that all bolts, screws, and knobs are secure every 90 days.
- Do not use or store this item in the proximity of open flame or flammable/combustible chemicals.
- If any parts are missing, broken, damaged, or worn, stop using this item until repairs are made and/or factory replacement parts are installed.
- Do not use this item in a way inconsistent with the manufacturer's instructions as this could void the product warranty.

TOOLS REQUIRED



PHILLIPS
SCREWDRIVER



FLAT HEAD
SCREWDRIVER



ALLEN WRENCH
(PROVIDED)



330 LBS
TOTAL
CAPACITY



2 PERSON
ASSEMBLY



UP TO 90 MIN.
ASSEMBLY

HARDWARE

A CAM BOLT



22 PCS

B CAM LOCK



22 PCS

C M4 X 20MM
SCREW



10 PCS

D M4 X 30MM
SCREW



10 PCS

E DOOR HINGE
BRACKET



4 PCS

F M3 X 12MM
SCREW



31 PCS

G TABLE HINGE

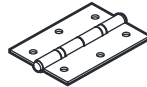

2 PCS

H JOINER PLATE



2 PCS

I TABLE
CONNECTOR



1 PC

J M4 X 18MM
BOLT



3 PCS

K KNOB



3 PCS

L SMALL
MAGNETIC
PLATE



1 PC

M M3 X 14MM
SCREW



12 PCS

N METAL PLATE



3 PCS

O LONG DOWEL



20 PCS

P SHELF
SUPPORT

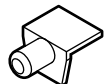

8 PCS

HARDWARE

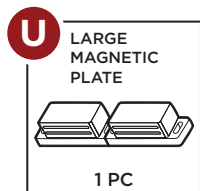
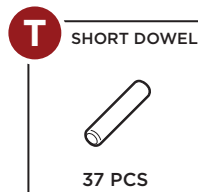
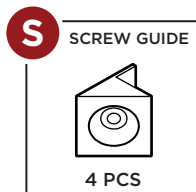
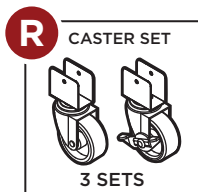
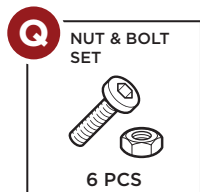

PARTS

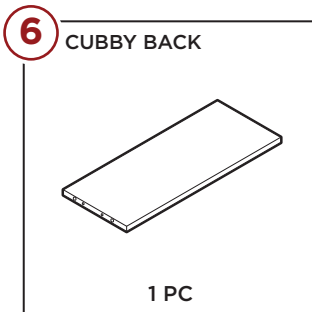
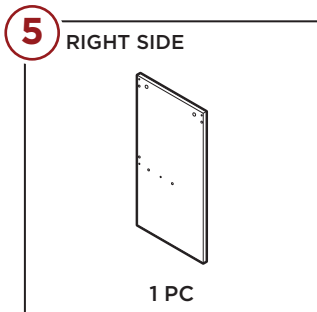
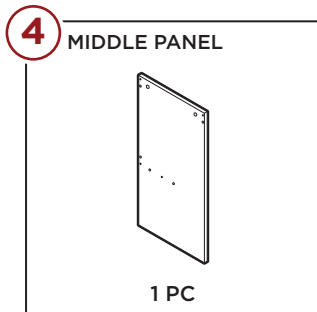
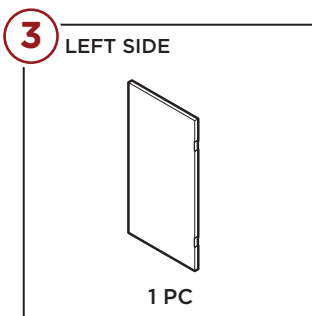
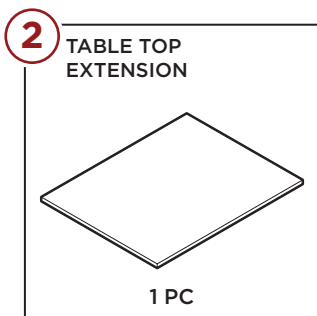
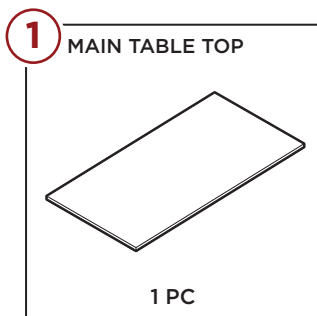

PARTS

7 CUBBY SHELF

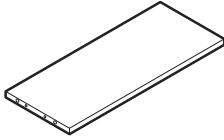

1 PC

8 SHELF BACKSPLASH

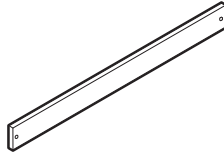

1 PC

9 CABINET BOTTOM

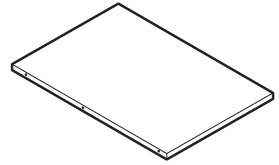

1 PC

10 CABINET BACK



1 PC

11 CABINET SHELF

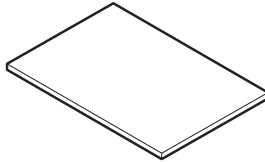

2 PCS

12 CUBBY DOOR I

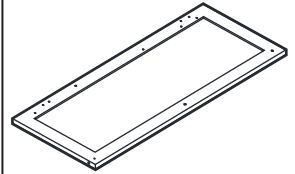

1 PC

13 CUBBY DOOR II

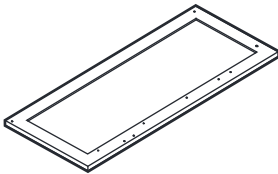

1 PC

14 CABINET DOOR

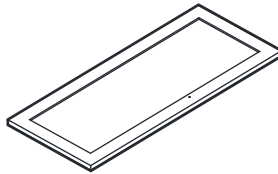

1 PC

15 SPOOL STORAGE

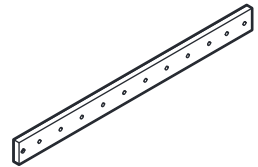

2 PCS

16 STORAGE BIN BACK

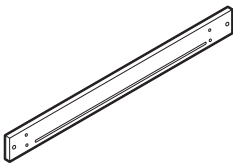

1 PC

17 STORAGE BIN FRONT

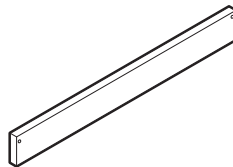

1 PC

18 STORAGE BIN SIDE



2 PCS

PARTS

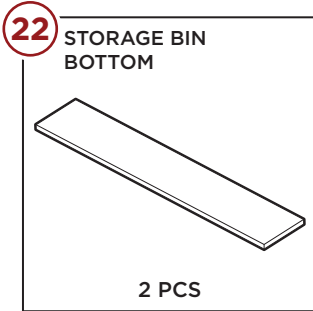
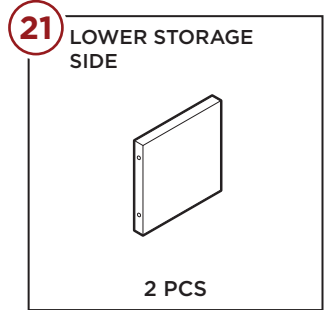
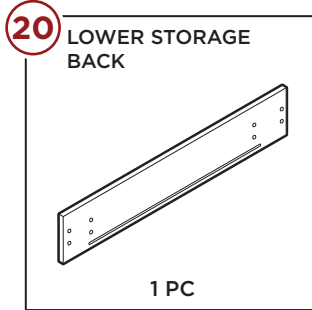
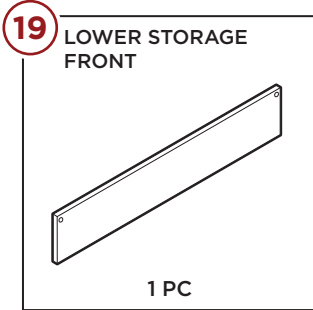

PRODUCT ASSEMBLY

1

Locate and connect the **part 12 & 13** cubby doors with three **part T** dowels.

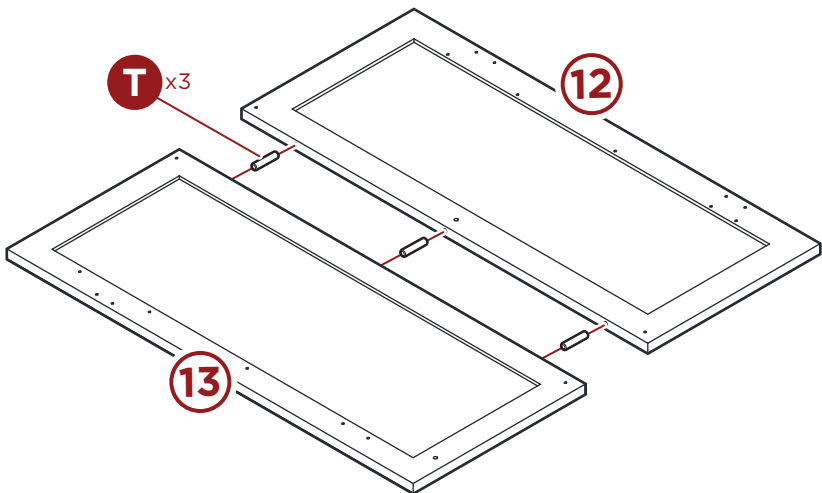

PRODUCT ASSEMBLY

2

Attach two **part H** joiner plates to the top and bottom of the two cubby doors with four **part M** screws.

Attach two **part N** metal plates to the **part 13** cubby door with two **part F** screws. Set aside this assembly.

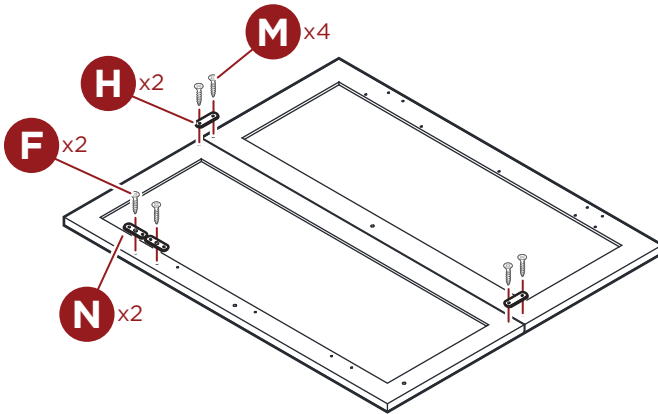

3

Attach two **part 21** lower storage sides to the **part 19** lower storage front with two **part T** dowels, secure with two **part D** screws.

Attach the **part 20** lower storage back to the **part 21** storage sides with two **part T** dowels, then secure with two **part D** screws. Set aside this assembly.

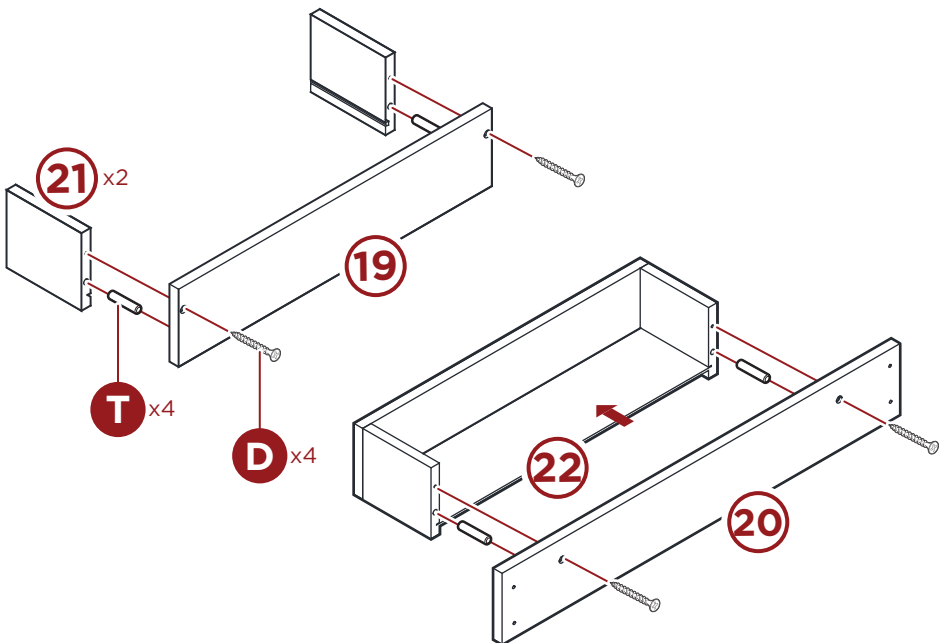

PRODUCT ASSEMBLY

4

Attach two **part 18** storage sides to the **part 17** storage front with two **part T** dowels, then secure with two **part D** screws.

Attach the **part 16** storage back to the **part 18** storage sides with two **part T** dowels, then secure with two **part D** screws.

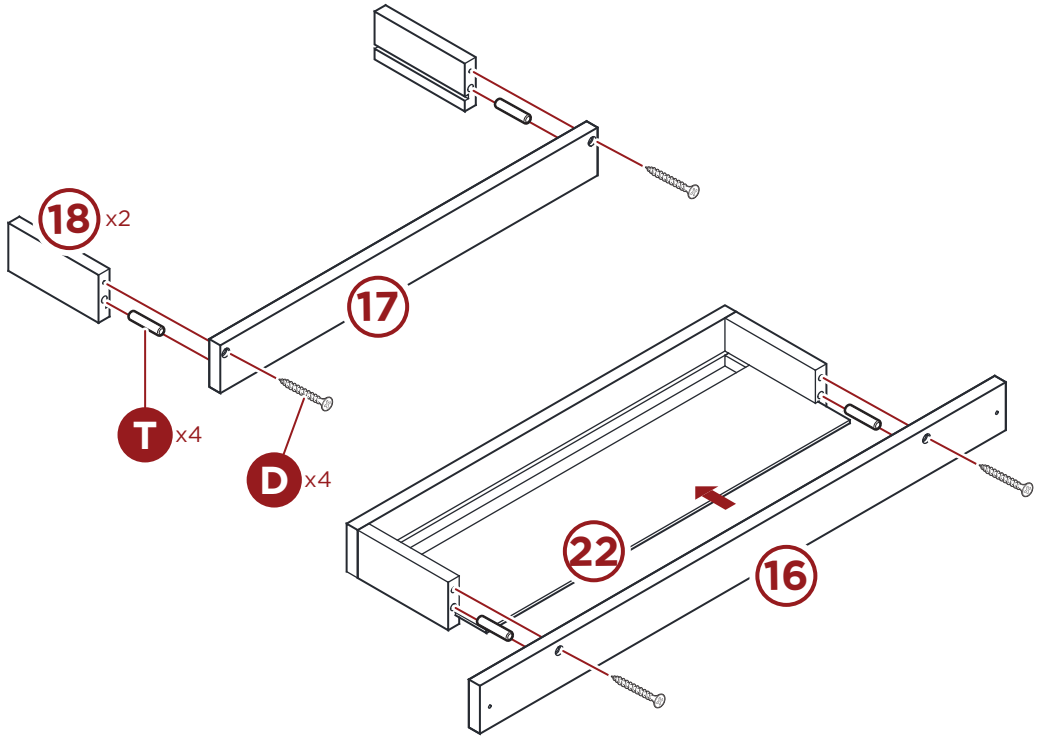

PRODUCT ASSEMBLY

5

Locate the cubby door assembly and attach two **part 15** spool storage panels with four **part C** screws, two screws per storage panel.

Attach the lower storage bin assembly to the cubby doors with two **part C** screws.

Attach the upper storage bin with four **part C** screws, two screws per side.

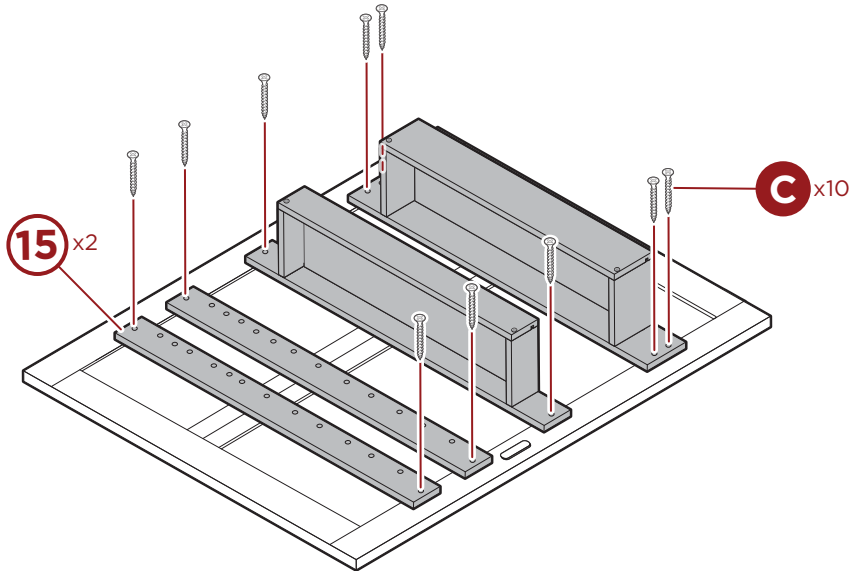

6

Attach two **part K** knobs with two **part J** bolts to the cubby door assembly.

NOTE: One knob per cubby door panel (**part 12 & 13**)

Attach **one locking caster** from one **part R** caster set to the **part 13** cubby door with one **part Q** nut & bolt set. Set aside this assembly.

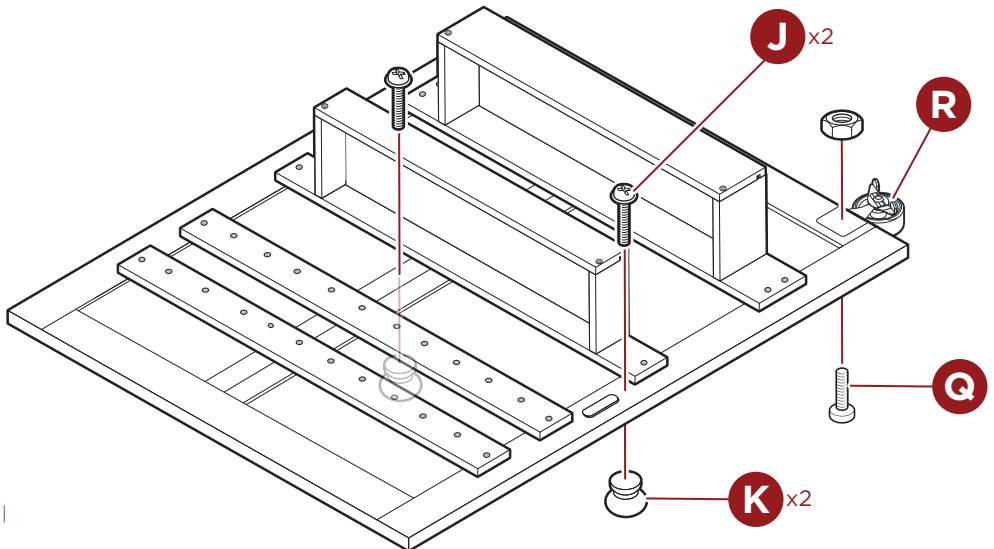

PRODUCT ASSEMBLY

7

Insert three **part A** cam bolts into the **part 5** right side, then attach two **part E** door hinge brackets with four **part F** screws, two screws per bracket.

Insert four **part A** cam bolts into the **part 3** left side, then attach two **part E** door hinge brackets with four **part F** screws, two screws per bracket.

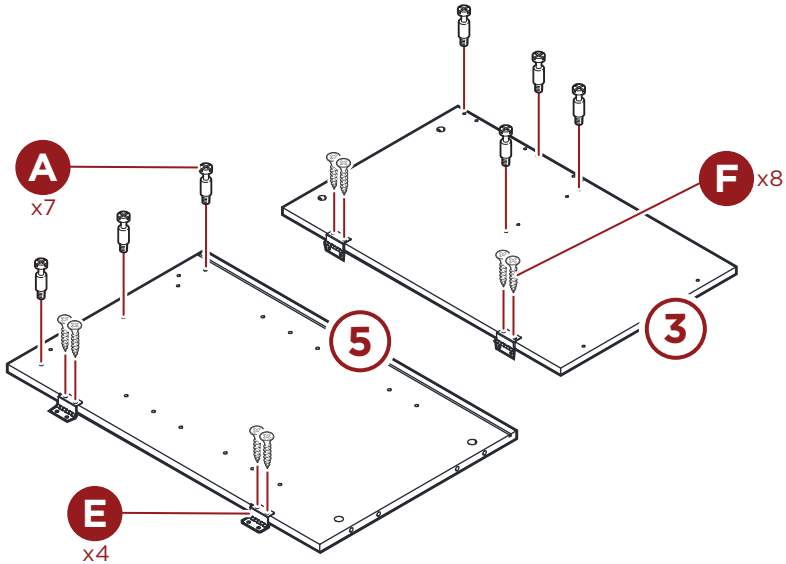

8

Insert three **part A** cam bolts into one side of the **part 4** middle panel, then attach one **part L** magnetic plate with two **part M** screws.

Flip the middle panel, then insert four **part A** cam bolts and attach one **part U** large magnetic plate with two **part M** screws.

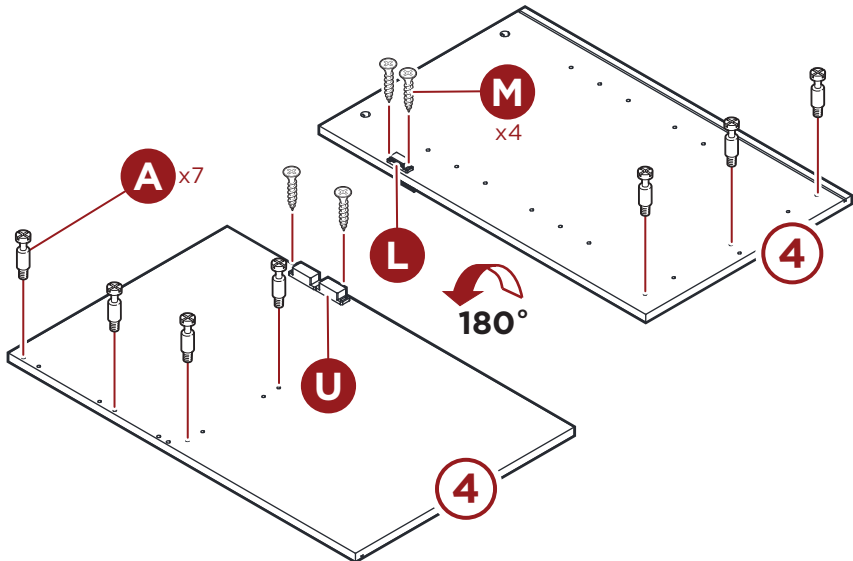

PRODUCT ASSEMBLY

9

Insert eight **part A** cam bolts into the **part 1** table top, then attach two **part G** table hinges with six **part F** screws.

Locate the **part 14** cabinet door and attach one **part K** knob with one **part J** bolt, then attach one **part N** metal plate with one **part F** screw.

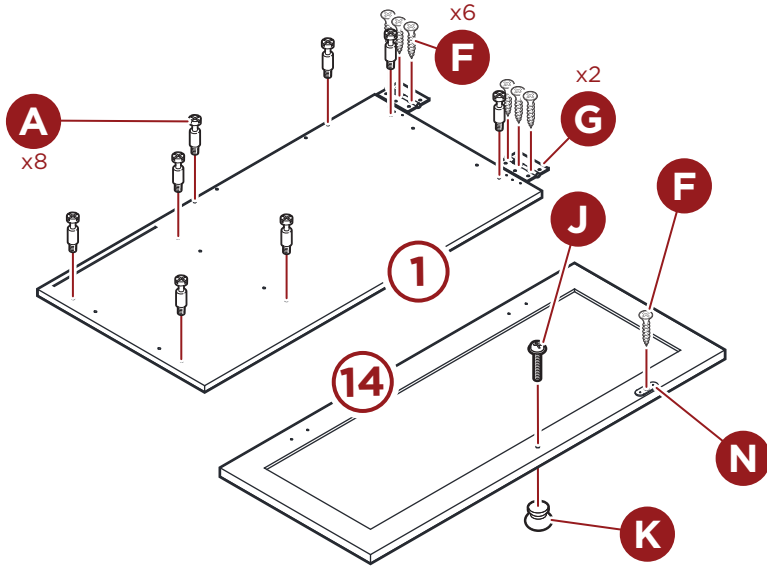

10

Attach the **part 8** shelf backsplash to the **part 7** cubby shelf with two **part T** dowels, then secure with two **part D** screws. Set this assembly aside.

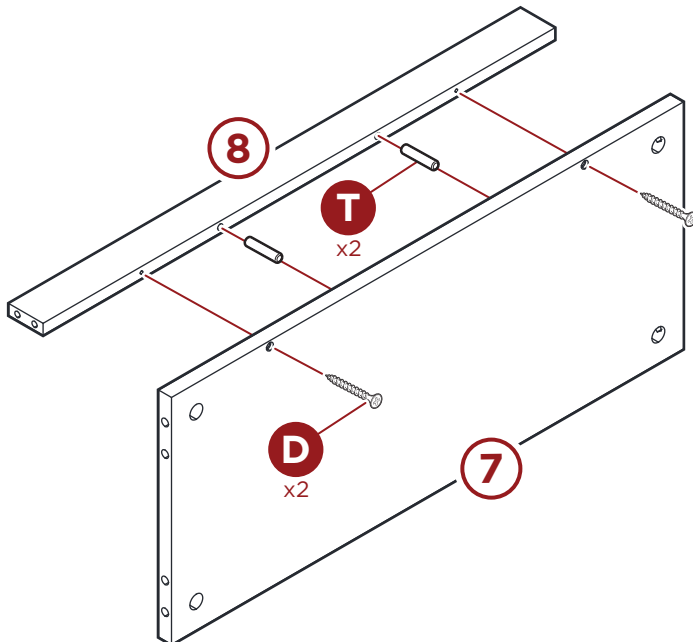

PRODUCT ASSEMBLY

11

Insert six **part B** cam locks and four **part T** dowels into the **part 9** cabinet bottom, then attach the cabinet bottom to the **part 5** right side and secure by turning the cam locks.

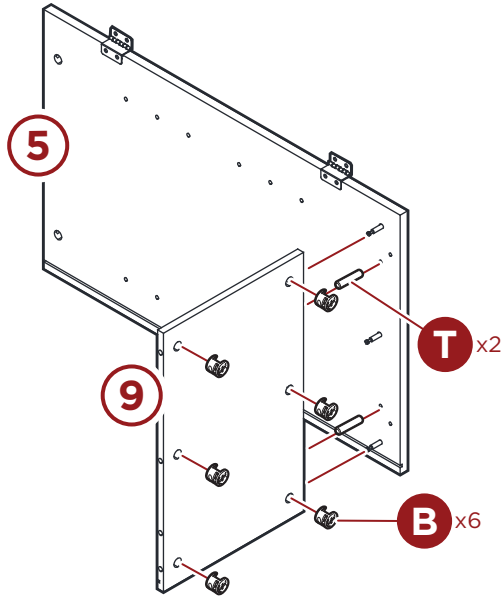

12

Attach the cabinet bottom to the **part 4** middle panel, and secure by turning the cam locks.

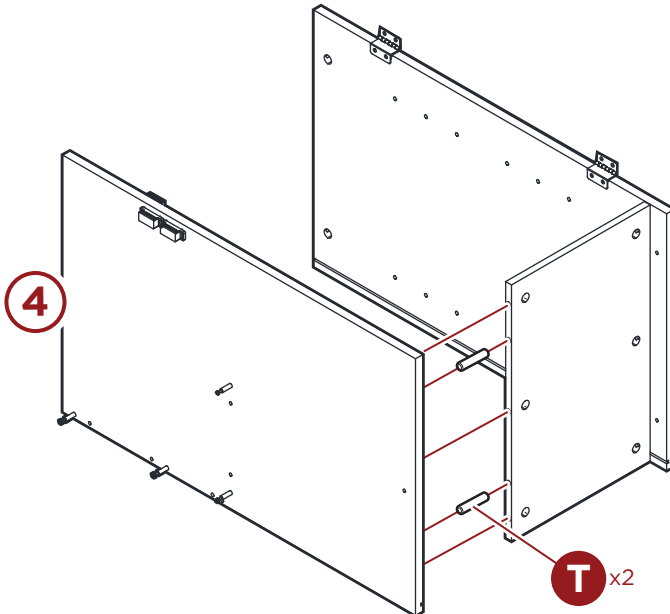

PRODUCT ASSEMBLY

13

Insert four **part B** cam locks and four **part T** dowels into the **part 7** cubby shelf.
Attach the shelf to the **part 4** middle panel.

Insert four **part B** cam locks and two **part T** dowels into the **part 6** cubby back, then attach the cubby back to the **part 4** middle panel, secure by turning all the cam locks.

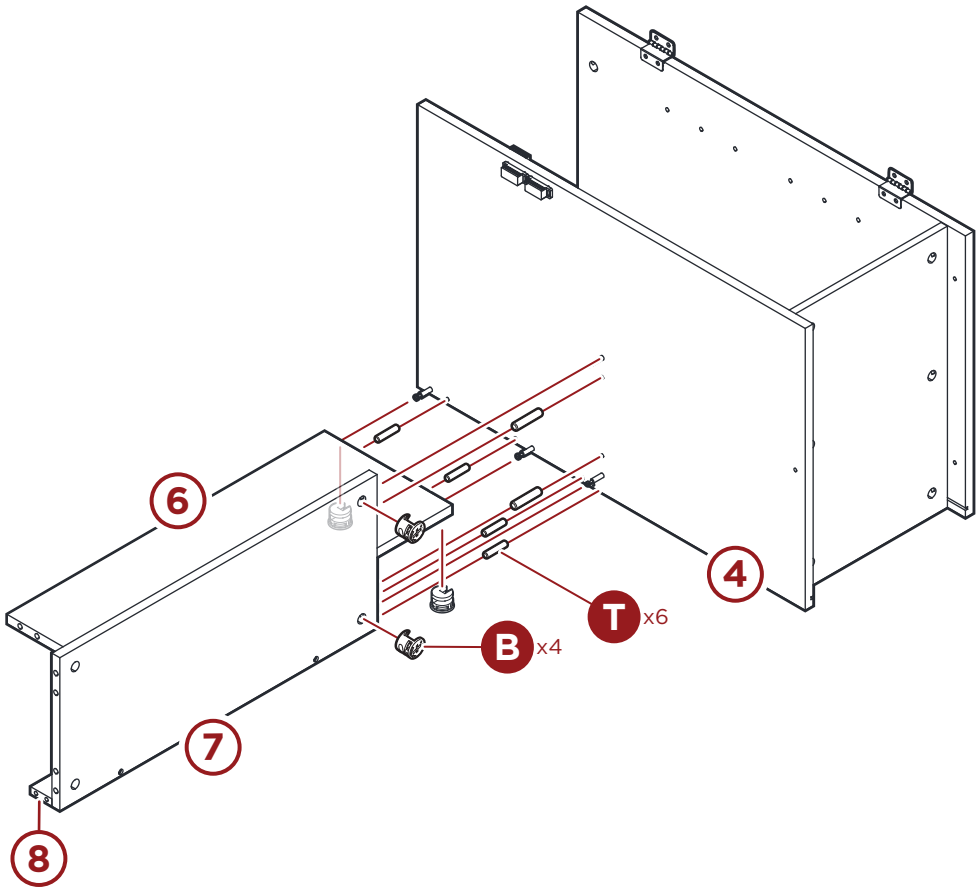

PRODUCT ASSEMBLY

14

Attach the **part 3** left side to the **part 7** cubby shelf and the **part 6** cubby back, secure by turning the cam locks.

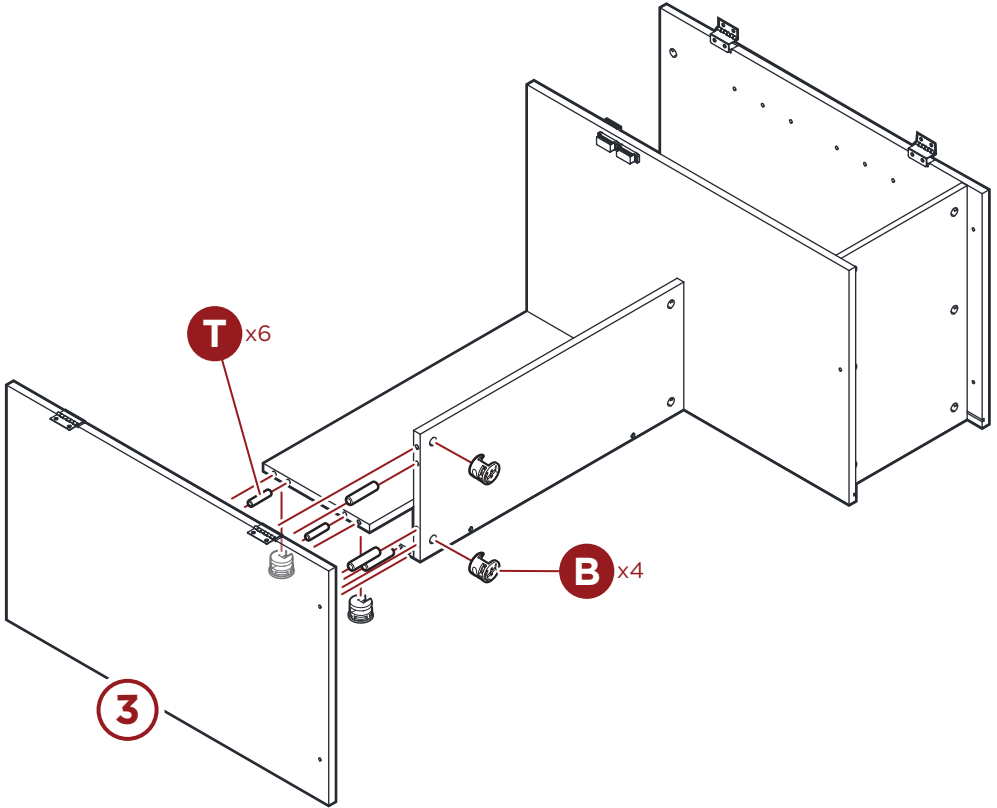

PRODUCT ASSEMBLY

15

Insert the **part 10 cabinet back** into the cabinet assembly.

Insert two **part B** cam locks and two **part T** dowels each into the **part 3** left side, **part 4** middle panel, and **part 5** right side. Attach the **part 1** main table top then secure by turning the cam locks.

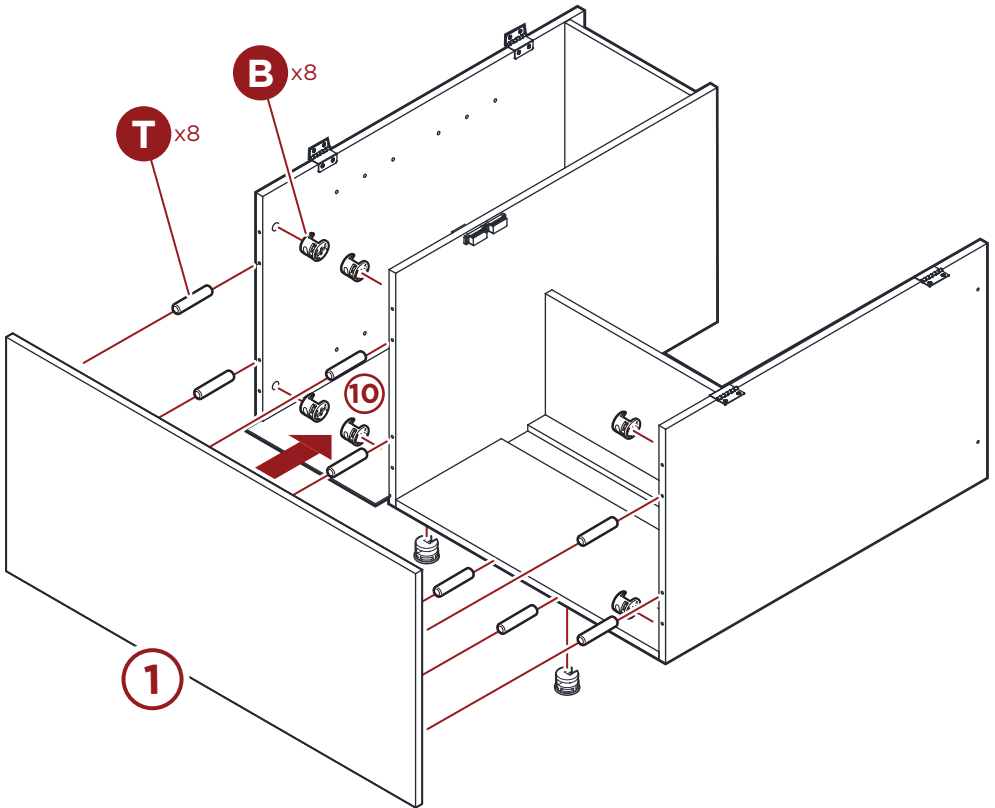

PRODUCT ASSEMBLY

16

Attach the **part 2** table top extension to the **part G** table hinges with six **part F** screws.

Attach one **part R** caster set to the **part 3** left side with two **part Q** nut and bolt sets.

Attach one **part R** caster set to the **part 5** right side with two **part Q** nut and bolt sets.

Attach the remaining caster (see step 6) to the **part 4** middle panel with one **part Q** nut and bolt set.

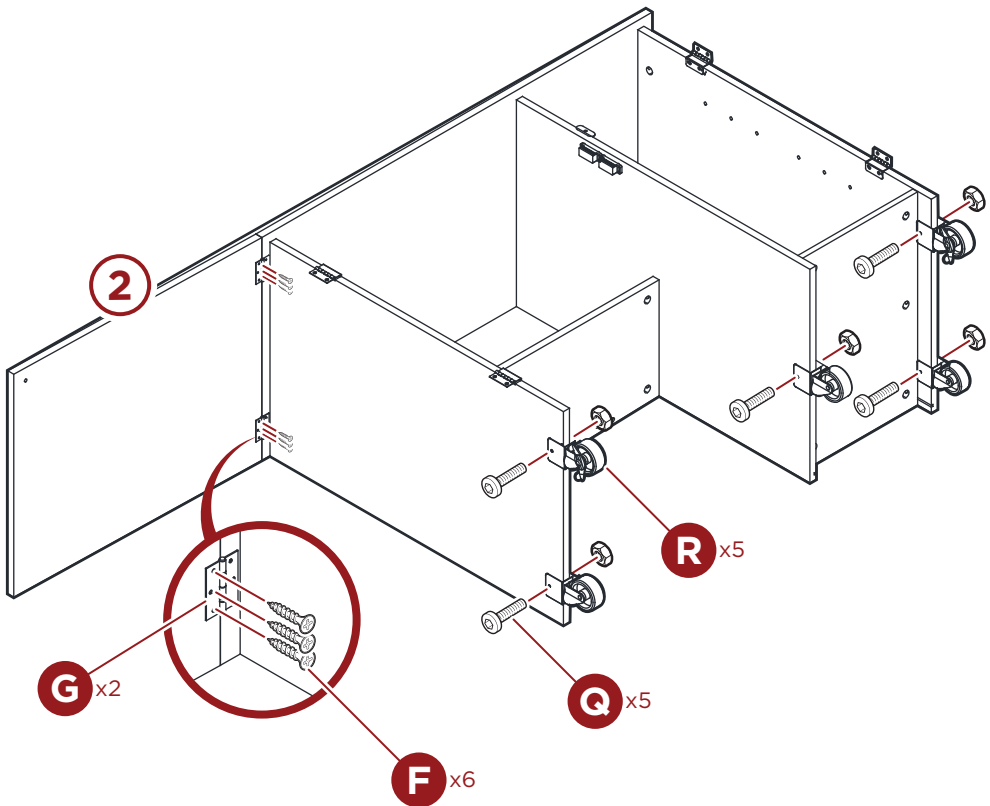

PRODUCT ASSEMBLY

17

Attach the **part 12** cubby door to the **part 3** left side by securing the **part E** hinge brackets with four **part F** screws. Then, open the cubby door and connect it to the **part 2** table top extension with one **part I** table connector.

Attach the **part 14** cabinet door to the **part 5** right side by securing the **part E** hinge brackets with four **part F** screws. Insert eight **part P** shelf supports into the **part 4 & 5** cabinet panels.

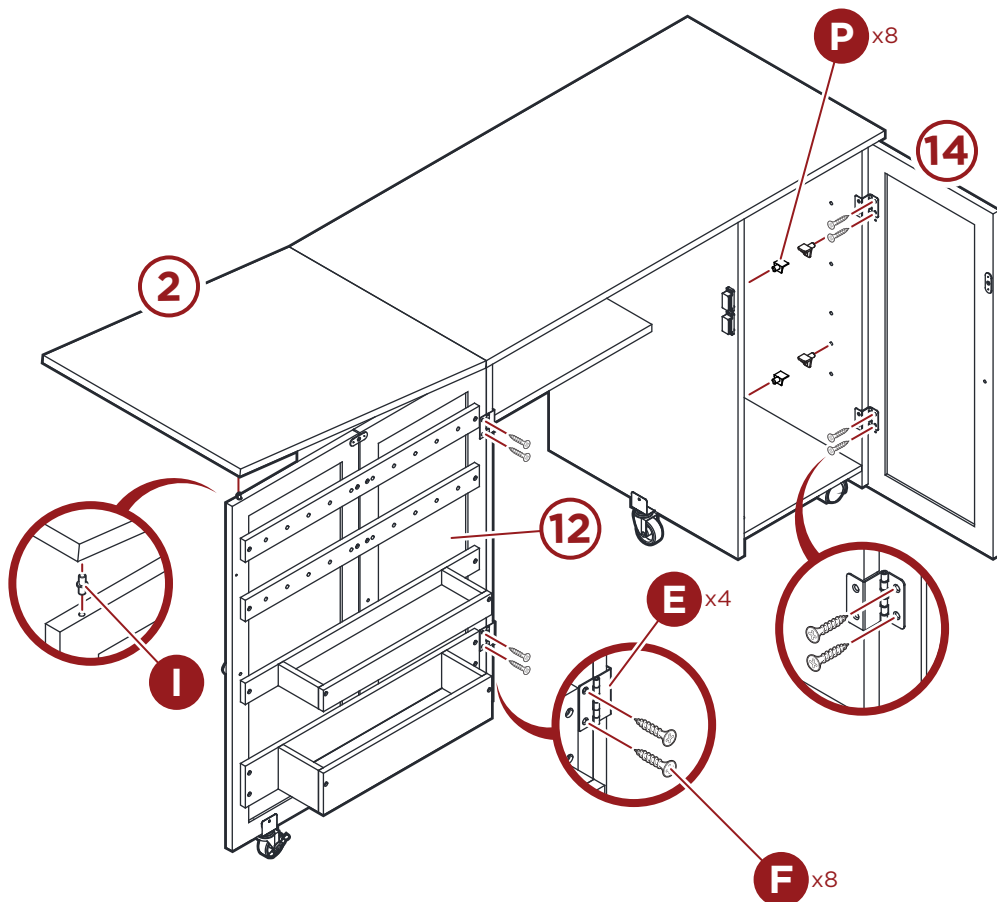

PRODUCT ASSEMBLY

18

Insert two **part 11** shelves and install twenty **part O** long dowels into the slots of the **part 15** spool storage plates.

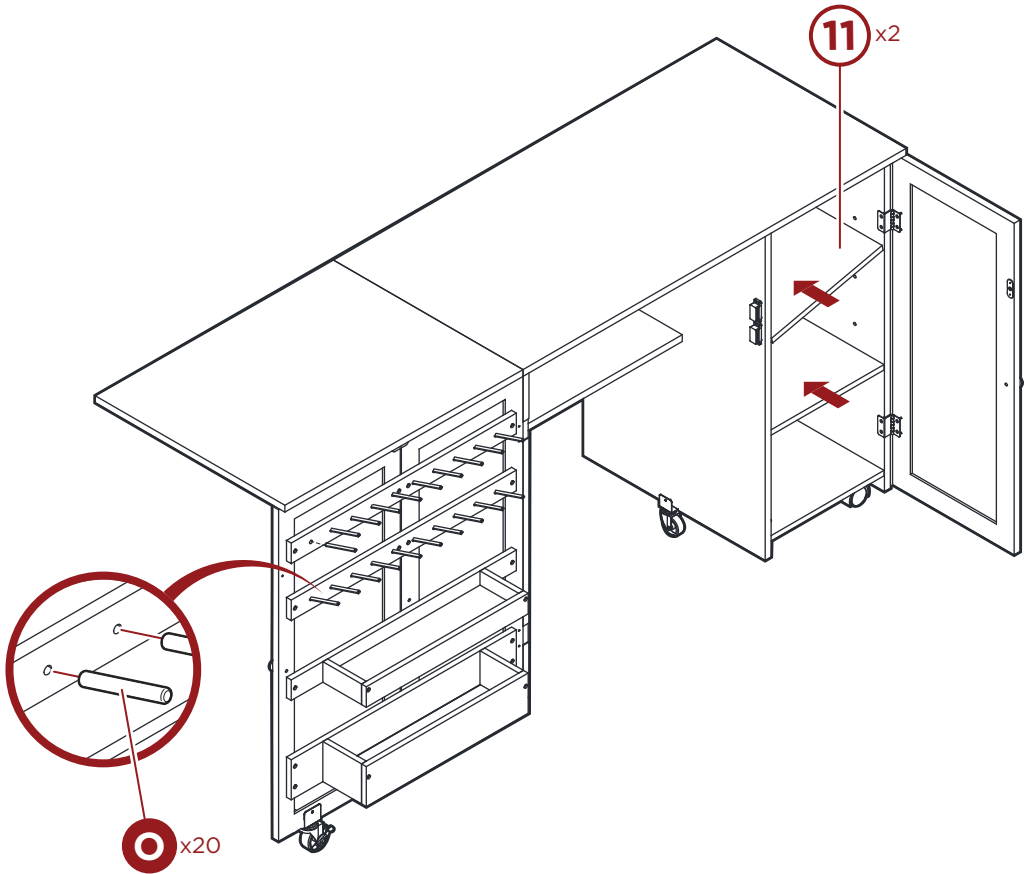

PRODUCT ASSEMBLY

19

Wedge four **part S** screw guides into **part 10 cabinet back** and then secure with four **part M** screws.

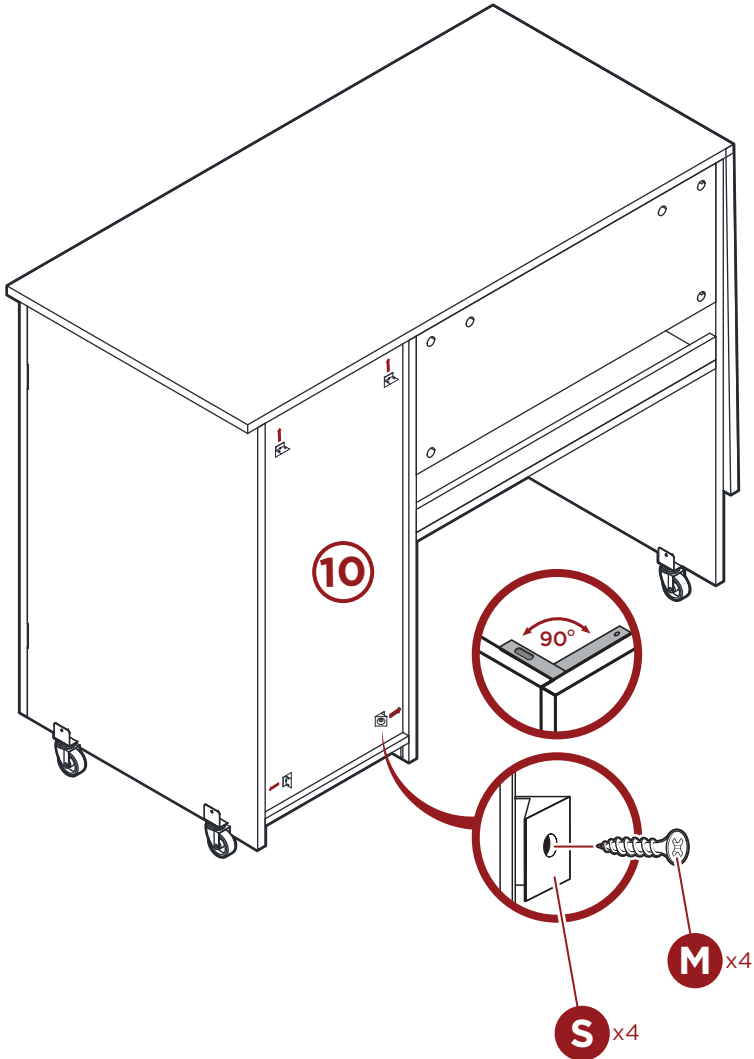

Earn points while you shop. Join today!

bestchoiceproducts
rewards

Join | Earn | Redeem

Give your friends 15% off their first order! For each successful referral you'll receive 100 points.

bestchoiceproducts.com



HELP CENTER



Question about your product? We're here to help. Visit us at:

help.bestchoiceproducts.com



Chat Support



Product Inquiry



Orders FAQ



Product Assembly



Returns & Refunds

PRODUCT WARRANTY INFORMATION

All items can be returned for any reason within 60 days of the receipt and will receive a full refund as long as the item is returned in its original product packaging and all accessories from its original shipment are included. All returned items will receive a full refund back to the original payment method. All returned items will not be charged a re-stocking fee.

All returned items require an RA (Return Authorization) number, which can only be provided by a Best Choice Products Customer Service Representative when the return request is submitted. Items received without an RA may not be accepted or may increase your return processing time. Once an item has been received by Best Choice Products, refunds or replacements will be processed within 5 business days.

All returns must be shipped back to the Best Choice Products Return Center at the customer's expense. If the reason for return is a result of an error by Best Choice Products then Best Choice Products will provide a pre-paid shipping label via email. Boxes for return shipping will not be provided by Best Choice Products, and is the customer's responsibility to either use the original shipping boxes or purchase new boxes.

Pictures may be required for some returns to ensure an item is not damaged prior to its return. Items returned are not considered undamaged until they are received by Best Choice Products and verified as such. All damages to items are the customer's responsibility until the item has been received by and acknowledge by Best Choice Products as undamaged.

WARNING

Manufacturer and seller expressly disclaim any and all liability for personal injury, property damage or loss, whether direct, indirect, or incidental, resulting from the incorrect attachment, improper use, inadequate maintenance, unapproved modification, or neglect of this product.