

NOTE: THIS DRAWING SHOWS INSTALLATION FOR RH BLIND CORNER.
SEE SHT. 2 FOR INSTALLATION IN LH BLIND CORNER.

CUSTOMER DRAWING

This drawing is the property of Rev-A-Shelf (RAS) and is disclosed in confidence to the extent its subject matter is original to RAS. Any vendor receiving this drawing from RAS shall hold and use this drawing for the sole benefit of RAS and shall not disclose it to, or use or reproduce it for any third party, or perform any act adverse to the interest of RAS with respect to this drawing without the express written permission of RAS. Vendors shall not revise any physical, dimensional or performance characteristic unless authorized by Rev-A-Shelf Engineering.

REV.	DATE	BY	DESCRIPTION OF CHANGE
A	5-9-11	KRR	ECN11-031

INCH [MM]		AMERICAN PROJECTION	DRAWN	BY	DATE	REV-A-SHELF, INC.	
				KRR	3-29-10	SIZE	35" HALF MOON NATURAL WOOD 2 TRAY ASSEMBLY
		TOLERANCES			MATERIAL	DRAWING NO.	SCALE
		MAT. DEC. (WOOD) .XX ±.03 [8mm] (OTHER) .XX ±.02 [5mm] (ALL) .XXX ±.005 [13 mm] FRACTIONS ±1/32 [8 mm]			FINISH	LD-4NW-882-35-1-CUST	0.125
		ANGLES ±1/2°				PART NO.	SHEET OF
						LD-4NW-882-35-1	1 3

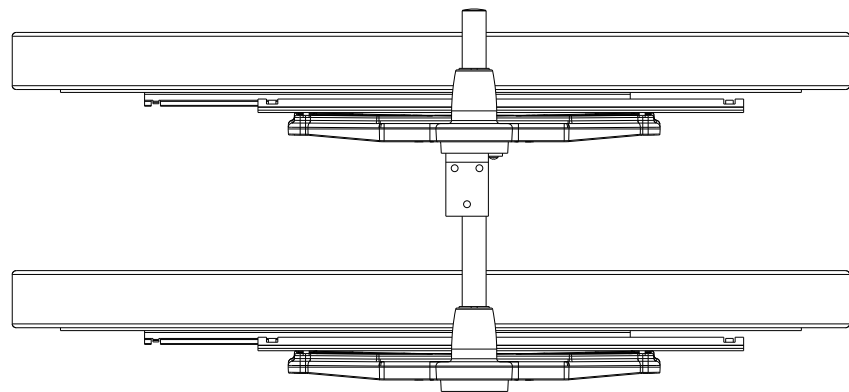
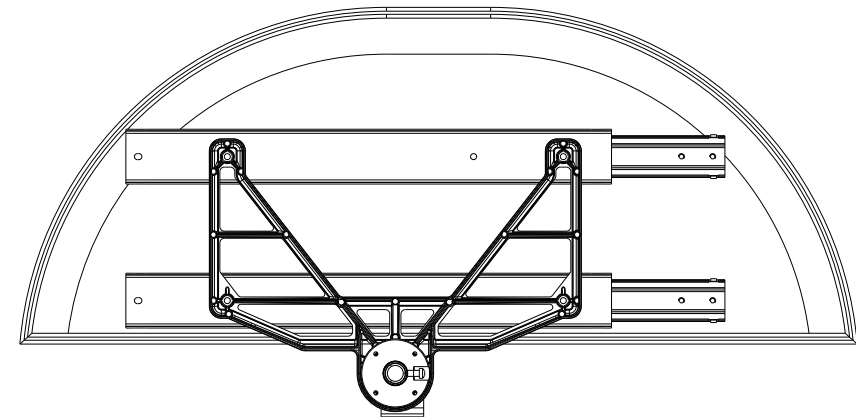
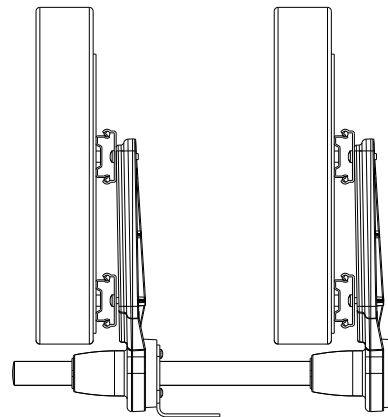
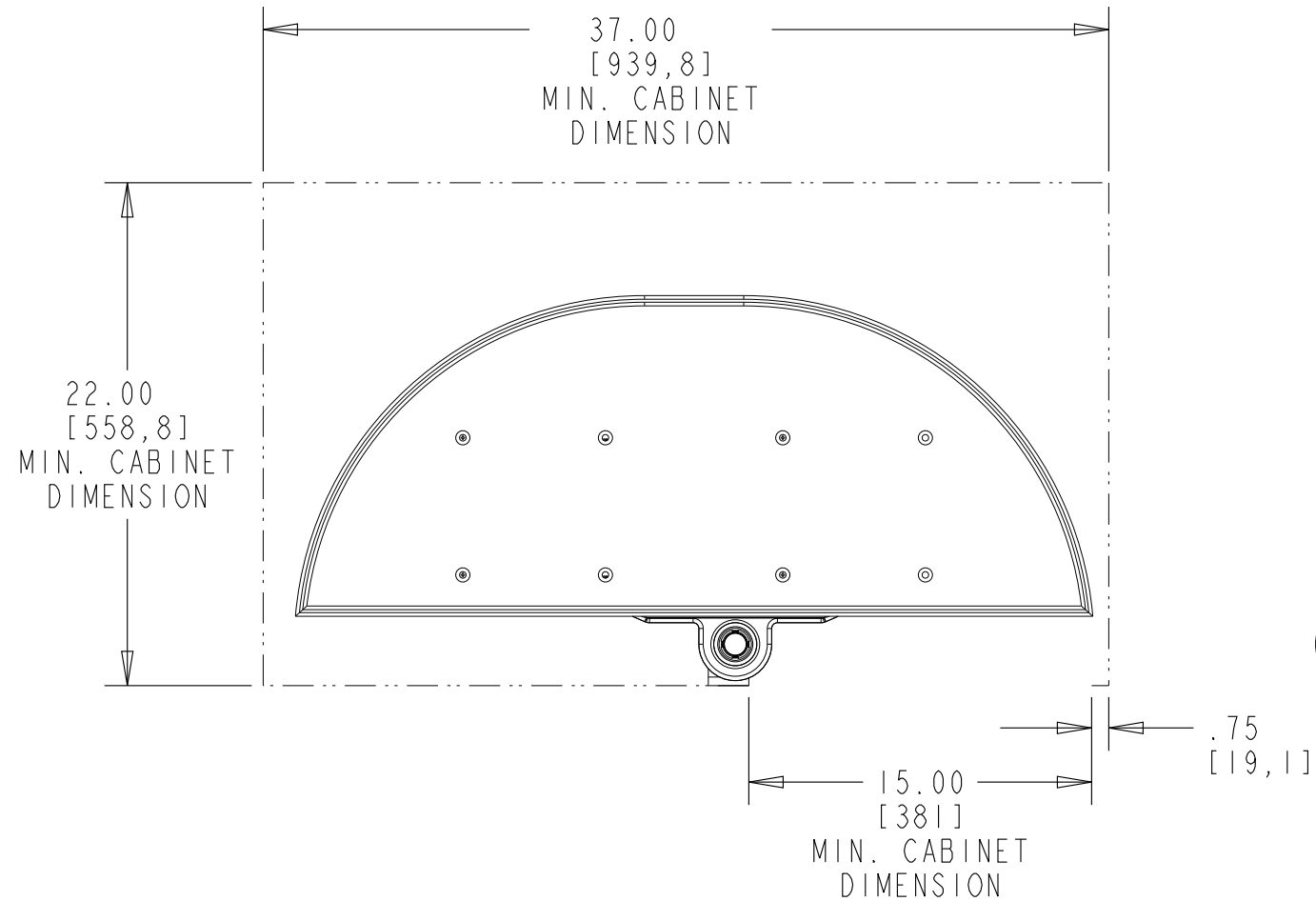

NOTE: THIS DRAWING SHOWS INSTALLATION FOR LH BLIND CORNER. SEE SHT. 1 FOR INSTALLATION IN RH BLIND CORNER.

CUSTOMER DRAWING

This drawing is the property of Rev-A-Shelf (RAS) and is disclosed in confidence to the extent its subject matter is original to RAS. Any vendor receiving this drawing from RAS shall hold and use this drawing for the sole benefit of RAS and shall not disclose it to, or use or reproduce it for any third party, or perform any act adverse to the interest of RAS with respect to this drawing without the express written permission of RAS. Vendors shall not revise any physical, dimensional or performance characteristic unless authorized by Rev-A-Shelf Engineering.

REV.	DATE	BY	DESCRIPTION OF CHANGE
A	5-9-11	KRR	ECN11-031

INCH [MM]	AMERICAN PROJECTION 	DRAWN	BY	DATE	REV-A-SHELF, INC.	
			KRR	3-29-10		
TOLERANCES		ANGLES ±1/2°	MATERIAL	DRAWING NO.		
MAT.	DEC.			LD-4NW-882-35-1_CUST		SCALE
(WOOD)	.XX ±.03 [.8mm]		FINISH	PART NO.		
(OTHER)	.XX ±.02 [.5mm]			LD-4NW-882-35-1		SHEET OF
(ALL)	.XXX ±.005 [.13 mm]					2 OF 3
	FRACTIONS ±1/32 [.8 mm]					

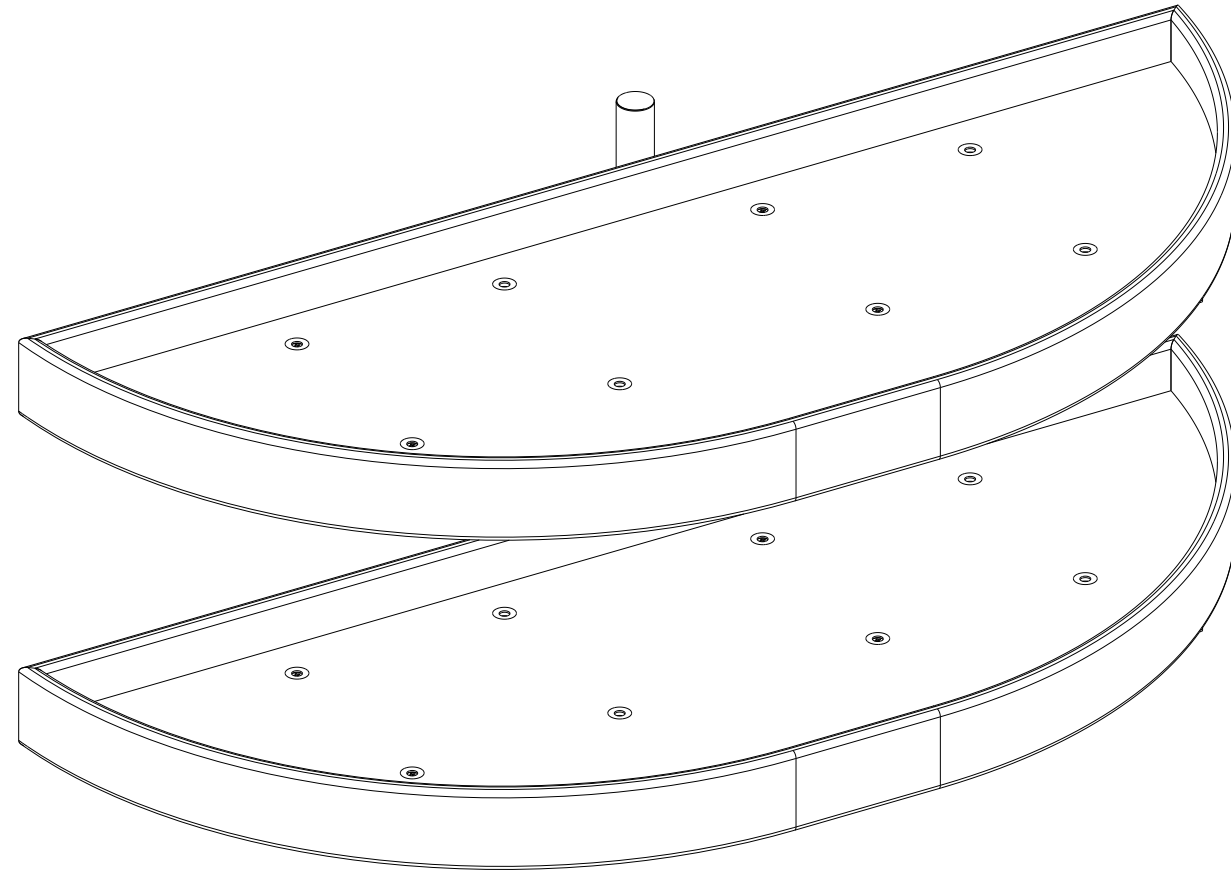

PART DIMENSIONS		
	MIN	MAX
WIDTH		34.89 [886,2]
DEPTH		17.06 [433,4]
HEIGHT		15.94 [404,8]
WEIGHT		

MIN CABINET OPENING	
WIDTH	15.00 [381]
DEPTH	22.00 [559]
HEIGHT	16.25 [413]

PRODUCT MAX WEIGHT RATING
35 Lbs PER TRAY

SLIDE SPECIFICATIONS				
SLIDE TYPE	BI-DIRECTIONAL BALL BEARING	SLIDE EXTENSION	3/4	MAX WEIGHT RATING
SLIDE CLOSING	N/A	SLIDE LENGTH	20.24	
SLIDE MOUNTING		SLIDE FINISH	ZINC	

CUSTOMER DRAWING

This drawing is the property of Rev-A-Shelf (RAS) and is disclosed in confidence to the extent its subject matter is original to RAS. Any vendor receiving this drawing from RAS shall hold and use this drawing for the sole benefit of RAS and shall not disclose it to, or use or reproduce it for any third party, or perform any act adverse to the interest of RAS with respect to this drawing without the express written permission of RAS. Vendors shall not revise any physical, dimensional or performance characteristic unless authorized by Rev-A-Shelf Engineering.

REV.	DATE	BY	DESCRIPTION OF CHANGE
A	5-9-11	KRR	ECN11-031

INCH [MM]	AMERICAN PROJECTION 	DRAWN	BY	DATE	REV-A-SHELF, INC.
			KRR	3-29-10	
TOLERANCES		ANGLES ±1/2°	MATERIAL	DRAWING NO.	SCALE
MAT.	DEC.		FINISH	LD-4NW-882-35-1_CUST	0.200
(WOOD) .XX ±.03 [.8mm]	(OTHER) .XX ±.02 [.5mm]		PART NO.	LD-4NW-882-35-1	SHEET 3 OF 3
(ALL) .XXX ±.005 [.13 mm]	FRACTIONS ±1/32 [.8 mm]				