

INSTALLATION INSTRUCTIONS

HTL-TW & SPTL-TW Series



⚠ WARNING

These products may represent a possible shock or fire hazard if improperly installed or attached in any way. Products should be installed in accordance with these instructions, current electrical codes, and/or the current National Electric Code (NEC).

⚠ WARNING

Use only with 24V DC drivers with a wattage capacity that can handle the total load; see page 2 for more details. Factory warranty will be void if used with a non-recommended power supply, transformer or driver.

⚠ WARNING

To reduce the risk of fire, electric shock or injury to persons, make sure that the electrical power to the system is disconnected at the source prior to installation or any servicing.

⚠ WARNING

Never fold Trulux® or bend past the minimum bending radius of 1" whether lighted or unlighted.

SAFETY INFORMATION

- Read all installation instructions before beginning; if not qualified, do not attempt installation. Contact a qualified electrician.
- To reduce the risk of fire, electric shock, or injury to persons, pay close attention to this manual and stay within its guidelines when using this product. Save these instructions for future use.
- Do not cover this product with paper surface coverings, fabrics, streamers, or other similar combustible materials.
- Do not operate Trulux on the reel, nor while it is coiled.
- This IP54 rated tape light is suitable for indoor use in dry and damp locations, but not for direct contact with water or moisture. Do not submerge flexible light in liquids, or use the product in the vicinity of standing water or other liquids, or where water can accumulate.
- Do not route the cord or tape light through walls, ceilings, doors, windows, or any similar part of the building structure.
- Secure tape light using only the adhesive provided with the tape and/or factory recommended mounting clips, mounting track, and aluminum channel (sold separately).
- Do not secure this product or its cord with staples, nails, or like means that may damage the outer jacket or cord insulation.
- Do not use if there is any damage to the tape light, diodes or power cord insulation; inspect periodically.
- Do not install on gates or doors, or where subject to continuous flexing.
- Do not install in airtight tanks or enclosures of any kinds.
- Size your 24V DC driver appropriately for your run distance. Be sure not to load a driver to 100% as this will reduce its efficiency; a 90% maximum load is recommended. See SELECTING POWER SUPPLY on page 2 and use driver chart as directed.

LAYOUT CONSIDERATIONS:

Pay close attention to the following tape light maximum run lengths. Use only the 24V DC power supply provided.

Tape Light Series	Wattage	Reel Length	Cuttability	Tape Light Maximum Run
HTL-TW Series	3.5W/ft	16.4 feet (5m)	Every 3.94"	22 feet (6.7m)
SPTL-TW Series	7W/ft	13.1 feet (4m)	Every 3.94"	13.1 feet (4m)

PRODUCT INFORMATION

IP54 reels include attached 6ft lead wires and (3) TL-4PWR-HD Heavy Duty connectors (IP20) with each reel.

Mount tape light using the 3M® VHB adhesive. Once the VHB protective backing is removed, the tape should be placed on the prepared mounting surface and not be repositioned, removed, or re-used. For best results, let adhesive cure 24 hours prior to first use

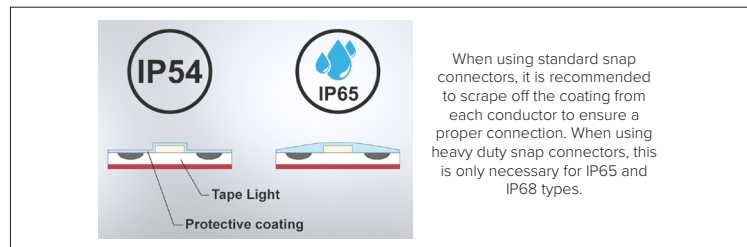

ADDITIONAL SAFETY MEASURES

1. Route and secure cords so that they will not be pinched or damaged in any way.
2. LEDs are bright. Do not look directly at lighted tape light.

Important Note: The National Electrical Code (NEC) does not permit cords to be concealed where damage to insulation may go unnoticed. To prevent fire danger, do not run cord behind walls, ceilings, soffits, or cabinets where it may be inaccessible for examination. Cords should be visually examined periodically and immediately replaced when damage is noted.

INSTALLATION INSTRUCTIONS

HTL-TW & SPTL-TW Series



INSTALLING TAPE LIGHT (SEE FIGURE 1):

Disconnect power from source prior to attempting installation. Make all connections and mount in place prior to providing power to system. Tape Light includes a 3M adhesive backing: Allow adhesive to cure 24 hours prior to first use. This product is designed to be mounted to a smooth, clean, non-moving surface.

1. Determine the placement of tape light and whether there will be cuts, splices, or jumpers needed. Make any cuts, splices, or jumps prior to moving on to Step 2. See CUTTING & LINKING TAPE LIGHT below for more information on cutting and/or linking Tape Light. Consider the placement of the power supply and ensure there is no tension from start of tape light to power supply.
2. Peel the protective backing from the tape light and press the tape light into place. For best results, once the VHB protective sheet is removed, the tape should not be repositioned, removed, or re-used.
3. Connect the beginning of the tape light to an appropriate tunable CCT DMX R.F. Controller, ensuring to match each wire to the appropriate terminal (24V black to +, CW to CW, and WW to WW).
4. Wire the controller to an appropriate LED driver, ensuring to match polarity (Red +, Black -).
5. Bring power to the direct wire power supply, ensuring to match polarity (Red +, Black -).

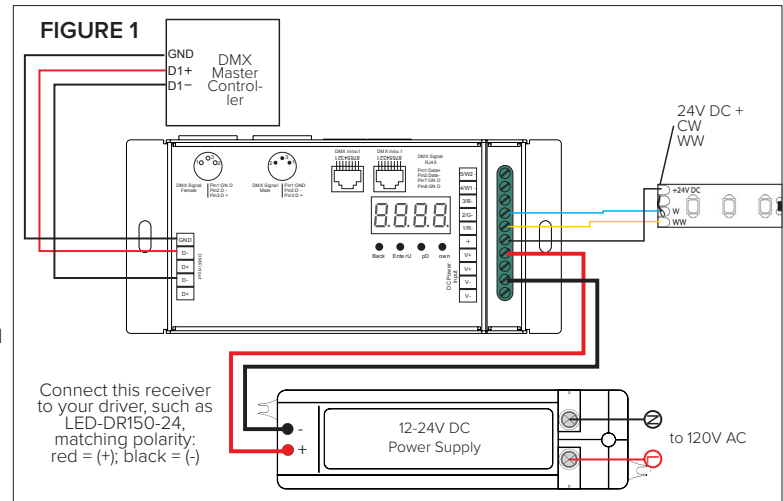

CUTTING & LINKING TRULUX® TAPE LIGHT (See Figures 2-7):

Do not exceed the maximum tape light run length of 16.4 feet in any single run. Use only the 24V DC power supply provided. Cut increments are clearly marked on the tape light (every 3.94"). Ensure an even cut slightly off center of the copper conductors to ensure enough surface area is exposed for snap connector pins to pierce through (See Figures 2 and 4).

Making a Tape-to-Tape Connection (See Figures 3-5):

1. Ensure the polarity of the conductors on the two pieces of tape light to be connected are aligned. See Figure 3.
2. Using a tape-to-tape snap connector, open both sides of the connector so the metal teeth inside are exposed. See Figure 4.
3. Peel a small portion of the protective backing from the tape light on the end to be connected, then insert cut tape light end so the copper pad conductors are aligned with the metal teeth inside.
4. Close snap connector and use pliers to ensure the connector "snaps" through the tape light. See Figure 5.

To make a Tape-to-Wire Connection (See Figures 6-9):

1. Using a tape-to-wire snap connector, follow steps 1-4 from "Making a Tape-to-Tape Connection" above to connect tape light.
2. Ensure polarity of the conductors on the connected piece of tape light and the polarity of the wires. See Figure 6.
3. Cut desired length of wire from the 15ft reel of wire included being sure to leave approximately 1/2' on each end to be connected.
3. Separate wires slightly so they fit in the grooves of the snap connector. There is no need to strip the wire. See Figure 7.
4. Insert the cut wire into the slots of the snap connector so the wire is aligned with the metal teeth inside. See Figure 8.
5. Close snap connector and use pliers to ensure the connector "snaps" through the wire. See Figure 9.

