

Item: KOAD1D

Assembly Instructions



Please visit our website for the most current instructions, assembly tips, to report damage or request parts. www.walkerediton.com

Revised 08/23-V-1

General Assembly Guidelines

- I. Ensure that all parts and hardware are available before beginning assembly.
- II. Follow each step carefully to ensure the proper assembly of this product.
- III. Two people are recommended for ease in the assembly of this product.
- IV. The three main types of hardware used to assemble this product are wood dowels, screws and bolts.
- V. A Phillips head screwdriver and hammer is required for the assembly of this product.

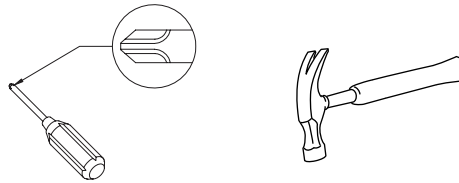

- V I. Power tools should not be used to assemble this product.

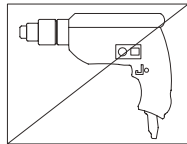



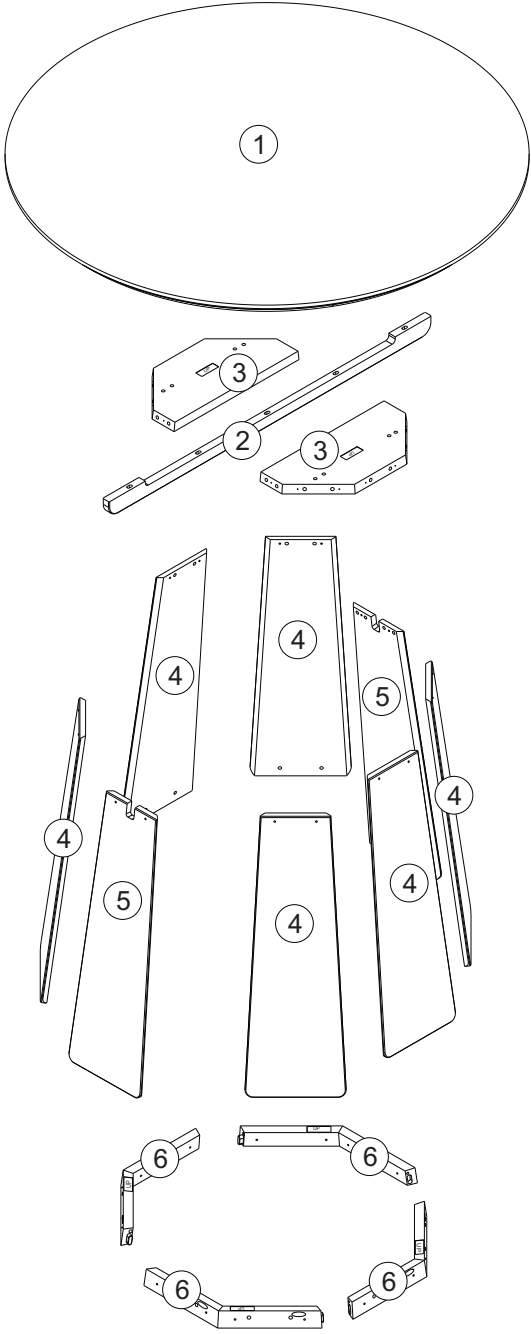

Parts List

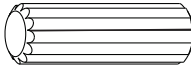
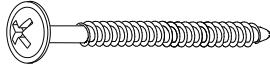
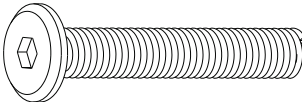
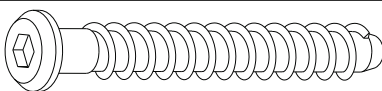

Part #	Description	Qty
1	Table top	01 pc
2	Rail	01 pcs
3	Octagonal panel	02 pc
4	Base panel	06 pcs
5	Base panel with cutout	02 pcs
6	Mounted rail	04 pcs

Hardware List

A		ø8*25mm	Wooden dowel	40 pcs
B		ø3,5*35mm	Screw	32 pcs
C		ø1/4"*40mm	Screw	09 pcs
D		ø7"*50mm	Screw	04 pcs
E			Hex Key	01 pcs
F		12mm	Washer	05 pcs
G			Adesive Felt	04 pcs

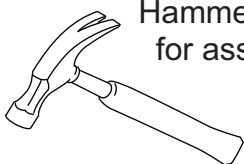

Hammer recommended
for assembly (not included)



Philips head screwdriver required
for assembly (not included)

*The hardware quantities listed above are required for proper assembly.
Some extra hardware may also have been included.*

Step 1

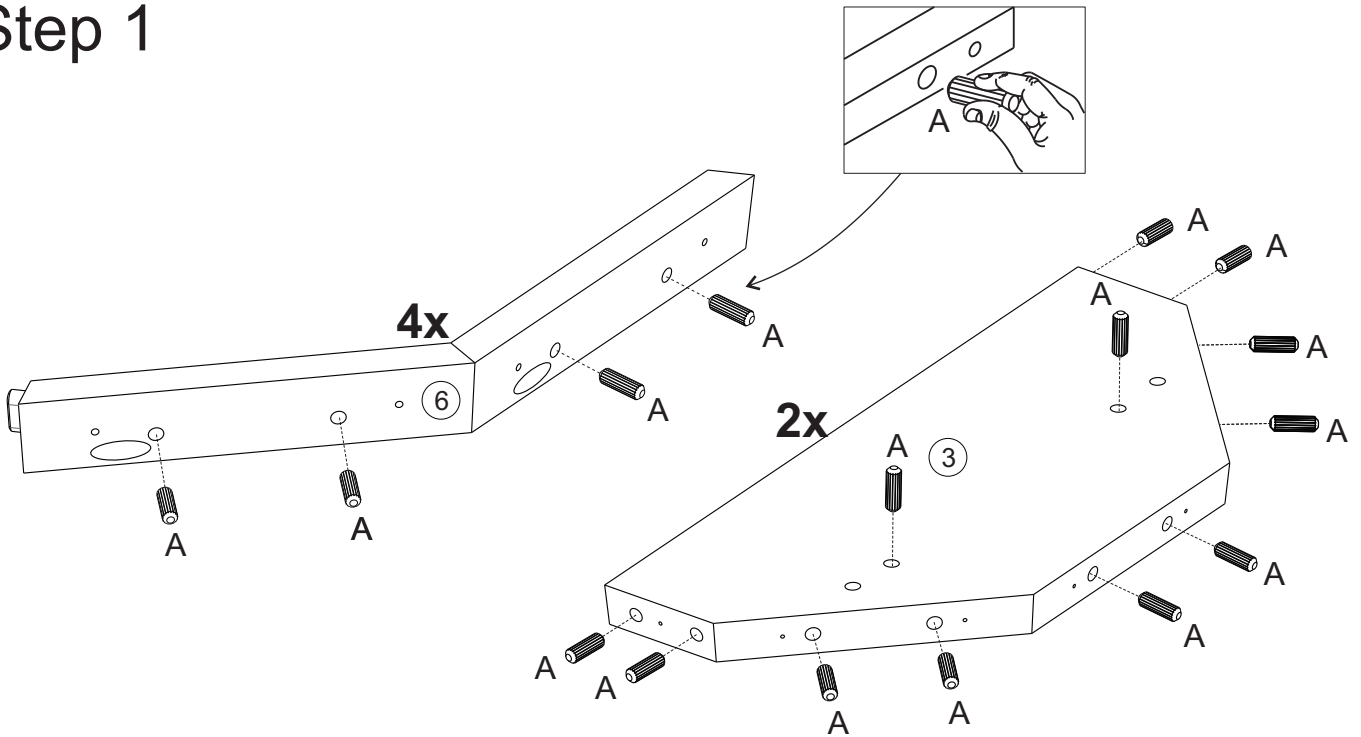

Insert wood dowel (A) into part 3 and 6.

A		ø8*25mm	40
---	--	---------	----

Step 2

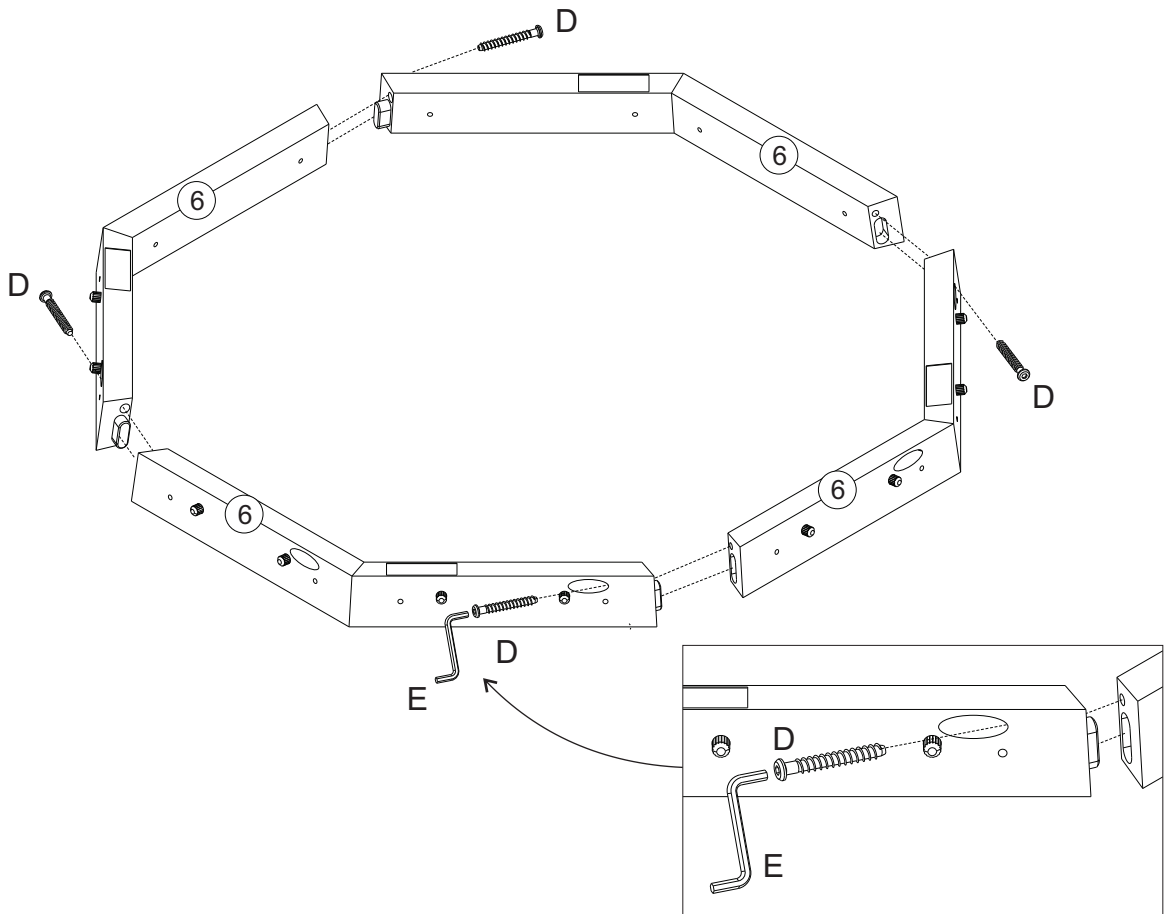

Fix parts 6 to each other with the screw (D) using a hex key (E).

D		ø7*50mm	04	E		Hex key	01
---	--	---------	----	---	--	---------	----

Step 3

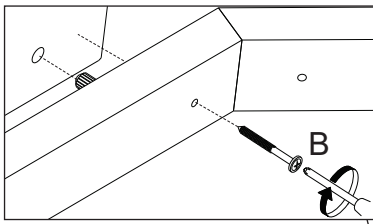

The UP label should be facing up as shown in step.

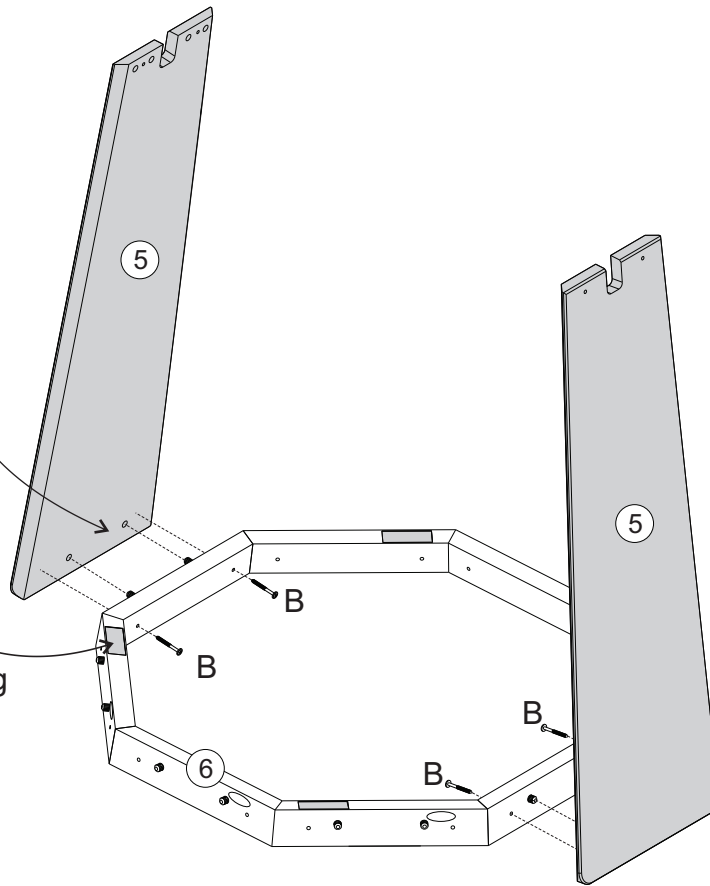

Fix the cut-out panels 5 to the mounted rails 6 with the screws (B), using a Philips Screwdriver.

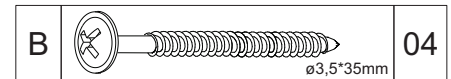

Step 4

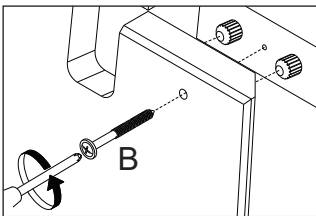

The UP label should be facing up as shown in step.

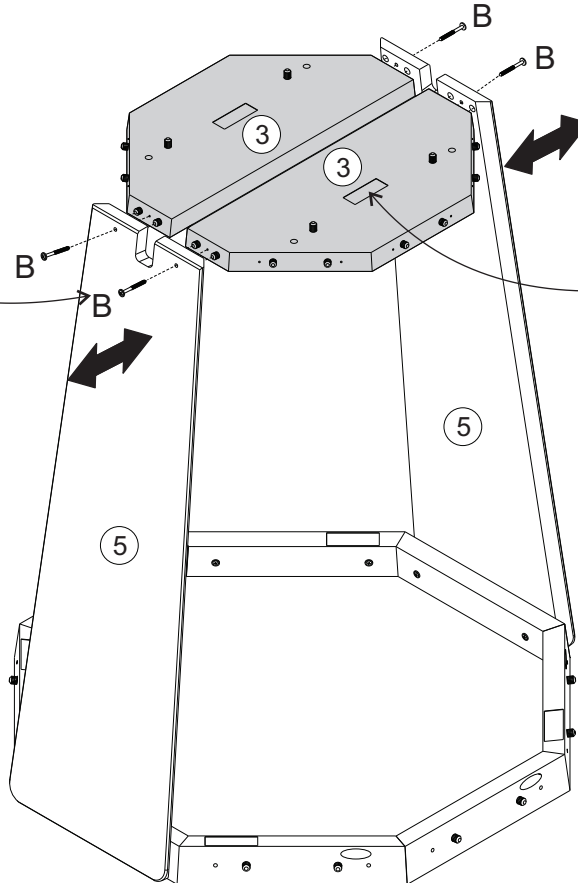

Fix the cut-out panels 5 to the octagonal panels 3 with the screws (B), using a Philips Screwdriver.

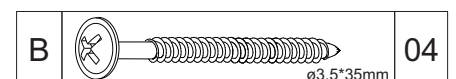

Step 5

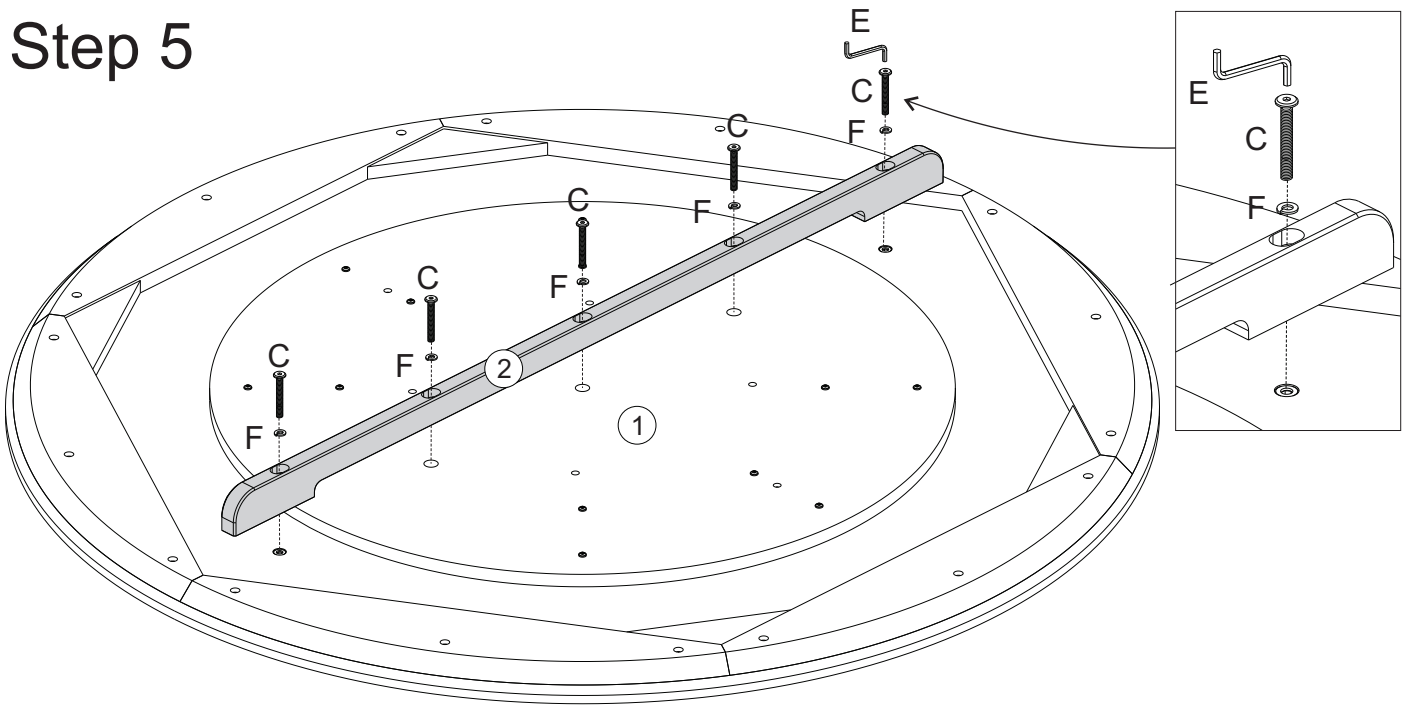

Fix the rails 2 on the table top 1 with the screws (C) and washer (F), using a hex key (E).

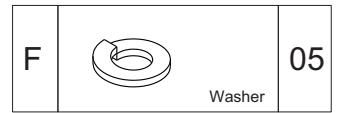
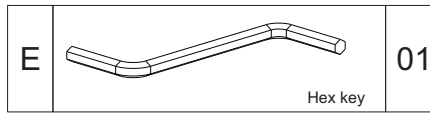
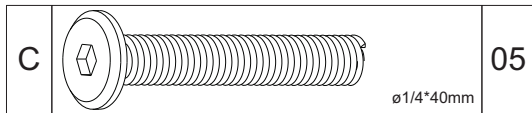

Step 6

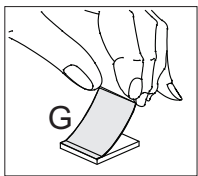

Before attaching remove the adhesive protection.

Please assemble on a clean soft surface to avoid damage.

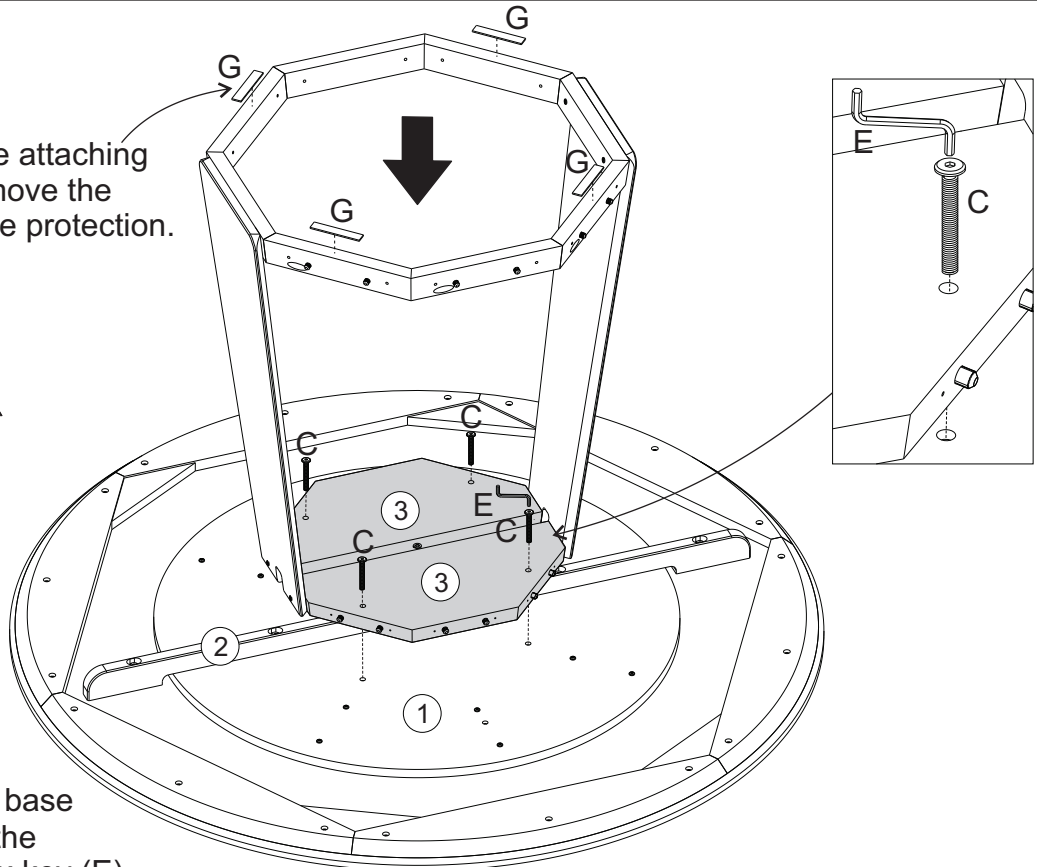

Fix the pre-assembled base to the table top 1 with the screws (C), using a hex key (E) and attach the adhesive felt (G) in part 6.

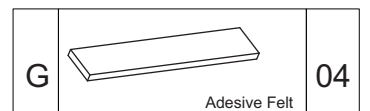
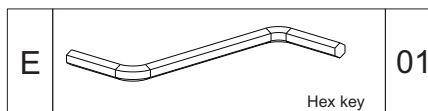
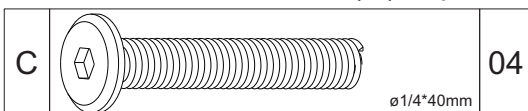

Step 7

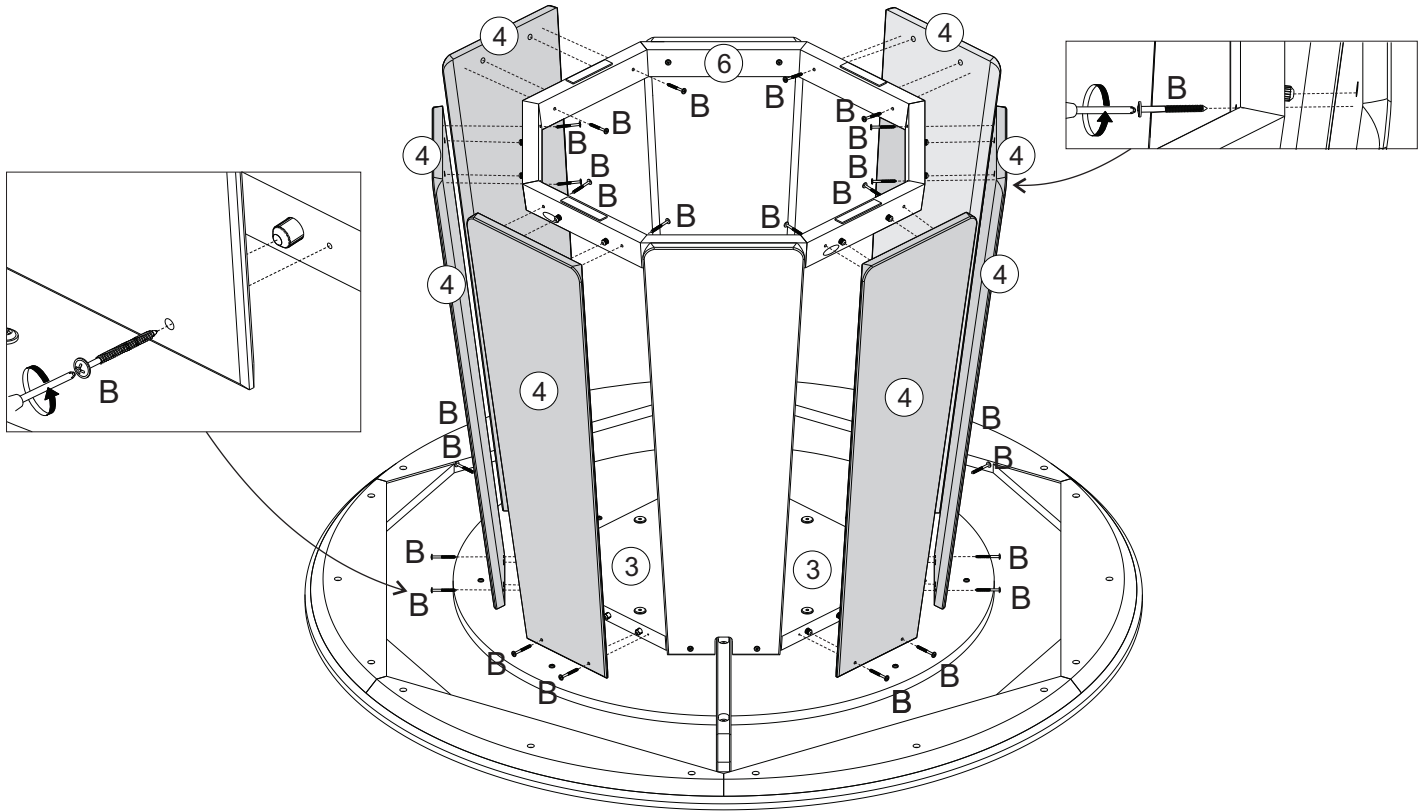

Fix the base panels 4 on the octagonal panels 5 and on the mounted rails with the screws (B), using a Philips Screwdriver.

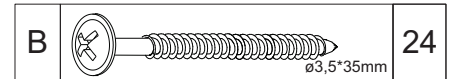

Step 8



Distributed weight.

W
E Walker
Edison[®]