

BLACK DIAMOND®

Project Name: _____

Location: _____

Item #: _____

Qty: _____

Black Diamond Warming Proofing and Hot Holding Cabinet, 4.94 Cu. Ft. Capacity, in Silver

BDPW14F



The Black Diamond Warming Proofing and Hot Holding Cabinet offers 4.94 Cu. Ft. of storage and accommodates 12 full-size 18" x 26" sheet pans, ideal for bakeries, restaurants, and catering operations. Designed with durable aluminum and plastic materials, this freestanding electric unit features a robust, reversible clear polycarbonate door for flexible installation. User-friendly knob controls and adjustable power settings make temperature management simple, with a wide range suitable for proofing and holding. Outfitted with corner bumpers and 5" casters for mobility and protection, this cabinet streamlines high-volume kitchen workflows. Covered by Black Diamond's standard product warranty.

FEATURES AND CONSTRUCTION

- Durable aluminum and plastic construction provide longevity and easy maintenance
- 4.94 Cu. Ft. interior capacity holds up to twelve 18" x 26" full-size sheet pans
- Clear polycarbonate reversible door delivers flexible access and product visibility
- Temperature range of 86°F to 203°F ensures optimal proofing and holding
- Freestanding installation type for flexible placement in commercial kitchens
- Equipped with 12 fixed shelves for organized pan management
- Mounted on 5" heavy-duty casters with integrated corner bumpers for mobility and protection
- 23"W x 33"D x 32"H overall dimensions fit a variety of space requirements
- Standard commercial warranty provides operational peace of mind

ELECTRIC

120V / 60Hz / 1Ph

Cord Length (Inches): 78.70

Plug Type: NEMA 5-15

Cord set included

NEMA 5-15P



3RD PARTY APPROVALS



WARRANTY (USA / CANADA)

One (1) Year Limited Warranty on Parts and Labor

Contact us for details at 1.877.368.2797



TEMPERATURE

- Temperature Range (Fahrenheit): 86 - 203

INCLUDED COMPONENTS

- Corner bumpers, 5" casters



Black Diamond Warming Proofing and Hot Holding Cabinet

BDPW14F

FRONT

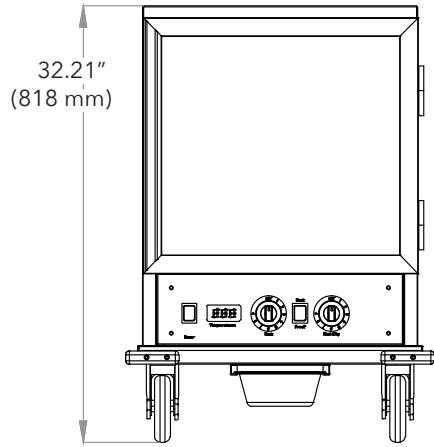

SIDE

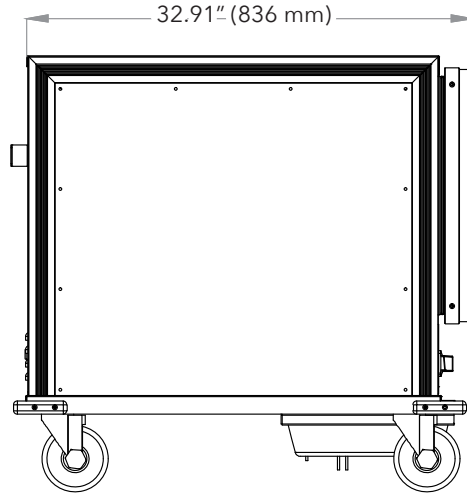

TOP

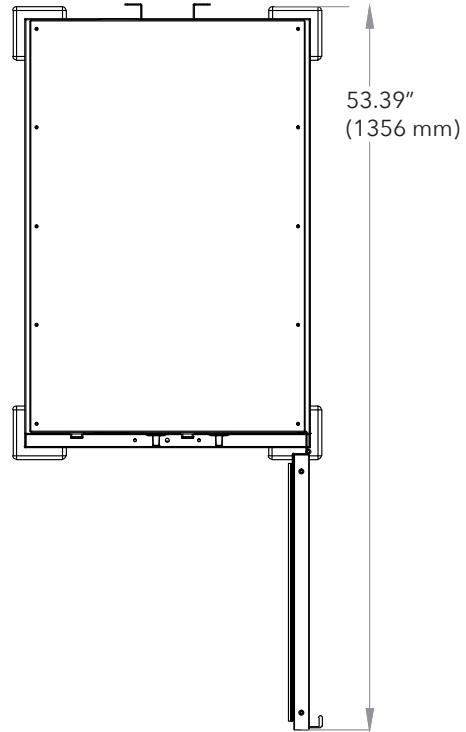
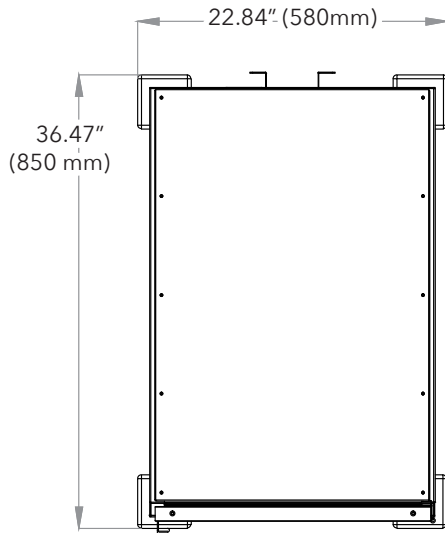

Proofing and Hot Holding Cabinet

Control Type	Amps	Wattage	Shelves	Capacity	Assembled Dimensions L x W x H (in)	Item Weight (lb)	Shipping Weight (lb)
Knob	12	1440	12	4.94 Cu. Ft. (12) Full Size, 18" x 26" Sheet Pans	33.00" x 23.00" x 32.00"	93.7	127.8

Due to periodic changes in designs, methods, procedures, policies and regulations, the specifications contained in this document are subject to change without notice. While we exercise good faith efforts to provide information that is accurate, we are not responsible for errors or omissions in information provided or conclusions reached as a result of using the specifications. By using the information provided, the user assumes all risks in connection with such use.