

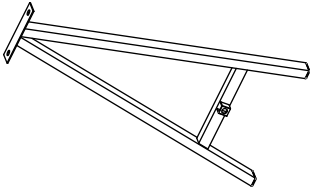



ASSEMBLY INSTRUCTION

E436-15(3A) MIRROR WRITING DESK WITH A SHAPE METAL LEG

A A-Shaped Leg  4pcs	B Stretcher  2pcs	C Mirrored Top  1pc
D Metal Frame  1pc	E Drawer Knob w/ Plastic Washer *Inside the drawer of Mirrored Top  1pc	F Bolt 1/4" X 5/8"  6pcs
G Bolt 1/4" X 5/8"  12pcs	H Washer 1/4"  8pcs	I Allen Wrench 1/4"  1pc

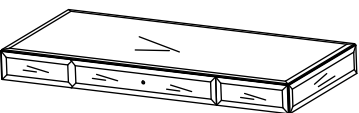
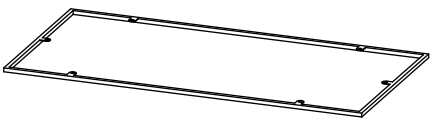

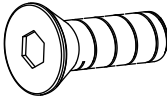
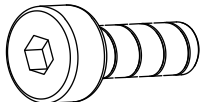
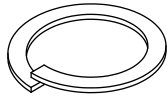
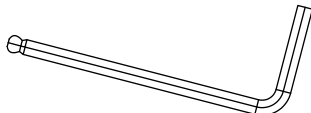
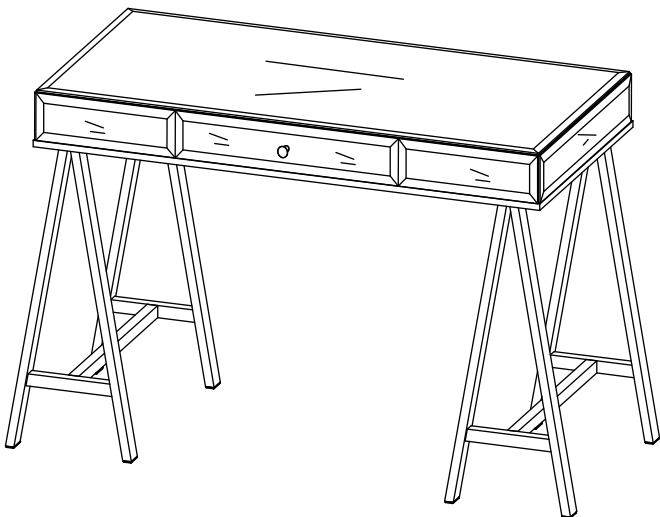
This page lists all the contents included in the box. Please take the time to identify the hardware as well as the individual components to this product. As you unpack and prepare for assembly, place the contents on a carpeted or padded area to protect them from damage.

***** Do not tighten screws & bolts until the entire unit is completely assembled.**

1 Attach A-shaped leg (A) to stretcher (B) by using bolt (G) and allen wrench (I) as shown.

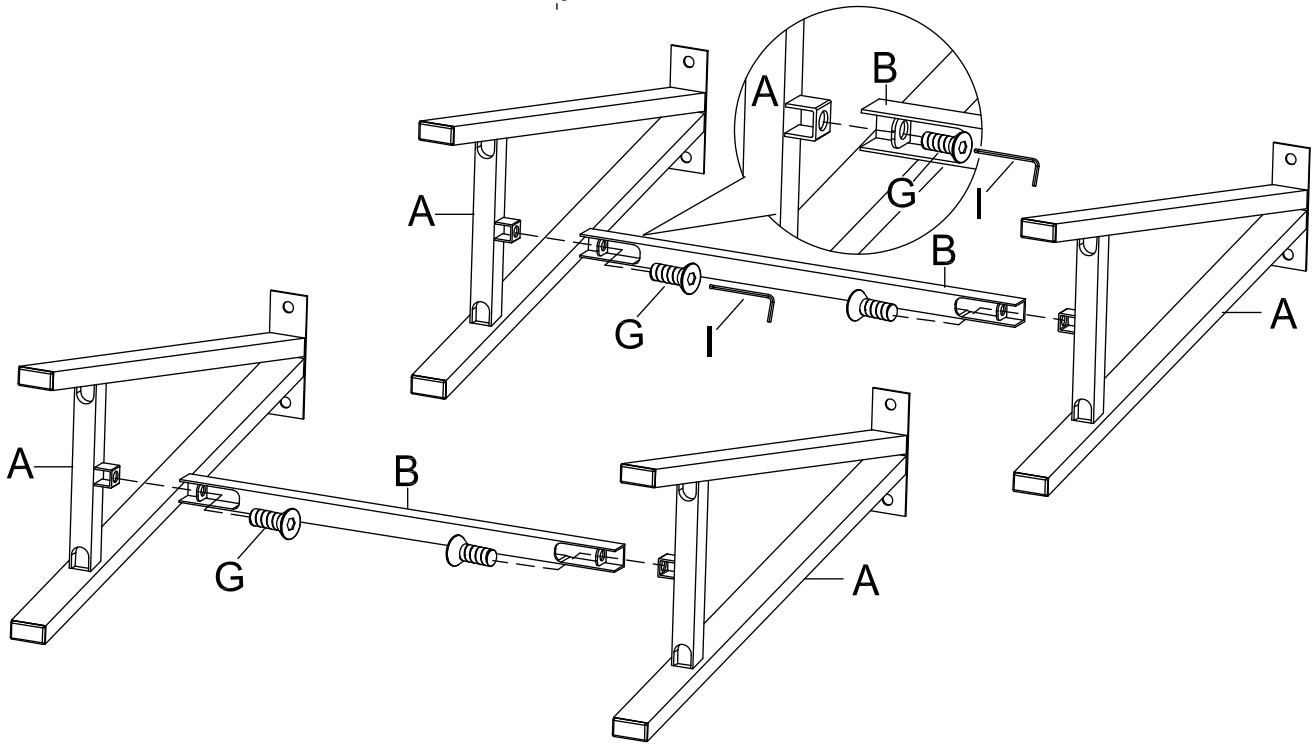

2 Attach metal frame (D) to mirrored top (C) by using bolt (F) and allen wrench (I) as shown.

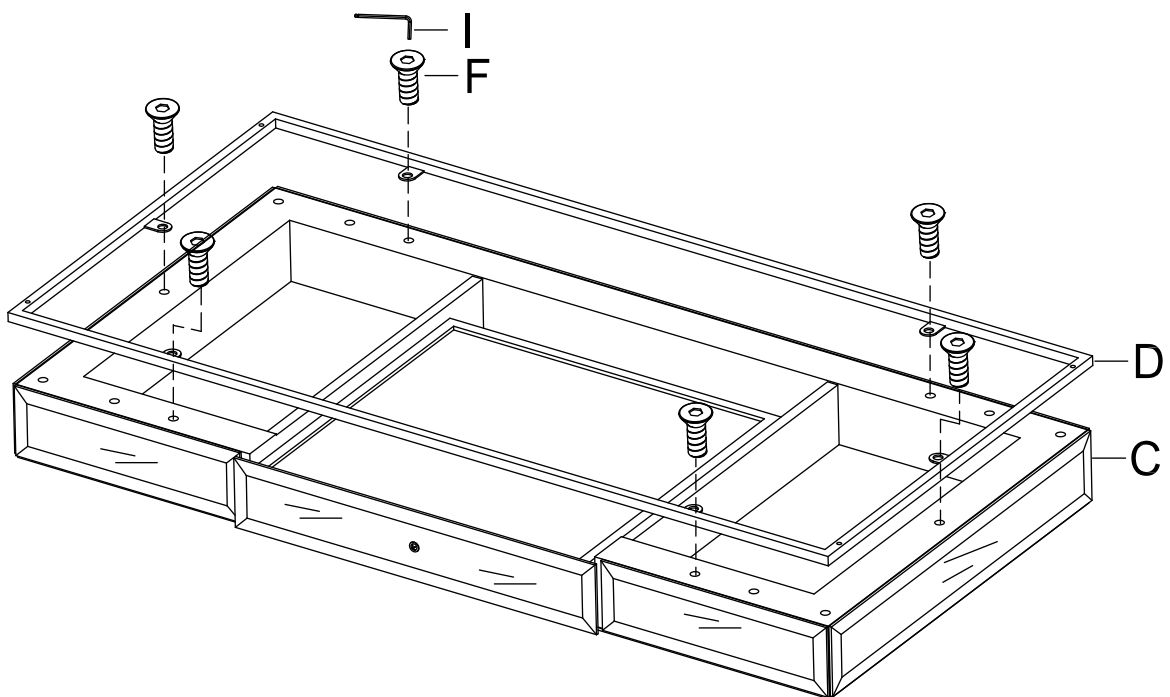

3

Attach A-shaped leg (A) to mirrored top (C) by using bolt (G), washer (H) and allen wrench (I) as shown. Tighten all bolts at this step.

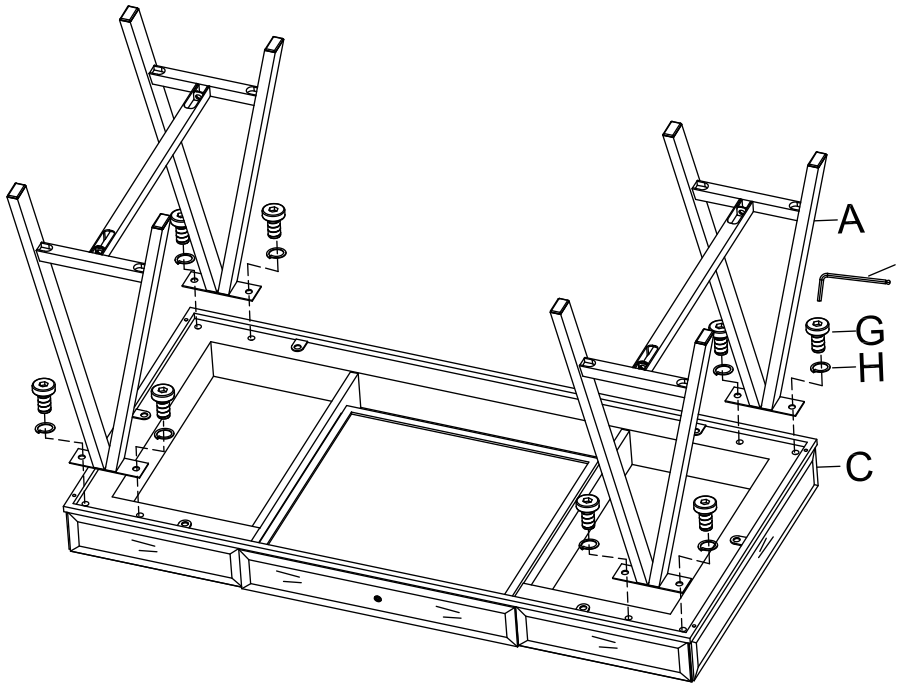
**4**

Carefully turn the assembled unit upright. Remove drawer knob (E) from inside of the drawer and reattach on drawer front as shown. The mirror writing desk assembly is now complete.

* © - The two plastic washers are for the purpose of protecting mirror surface. Please place one of the washers inside of the drawer and place the other one between front of the drawer and drawer knob.

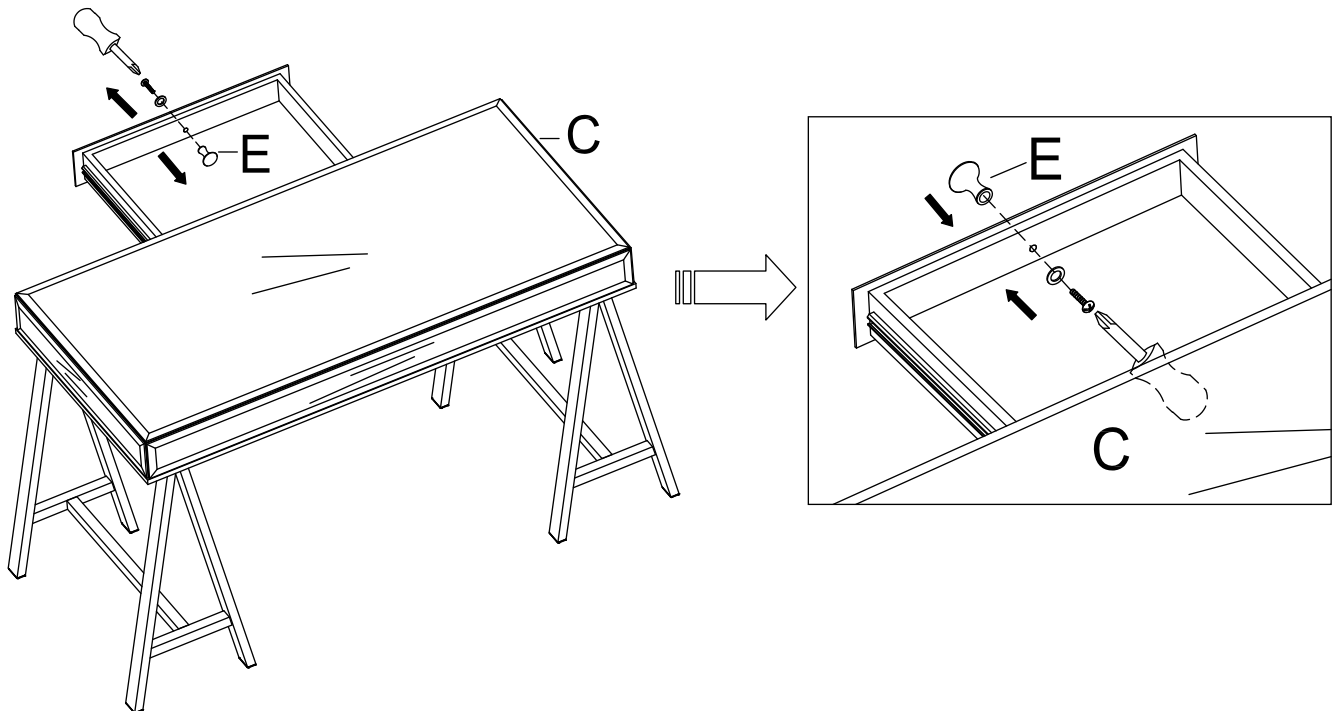

Cleaning & Care

Treat surface with care. Surface is resistant to scratches but is not scratch resistant. Clean surfaces with a dry or damp soft cloth. Do not use abrasive cleaners. Hardware may loosen over time. Periodically check that all connections are tight.