

BAR STOOL ASSEMBLY INSTRUCTION

MODEL 697-001

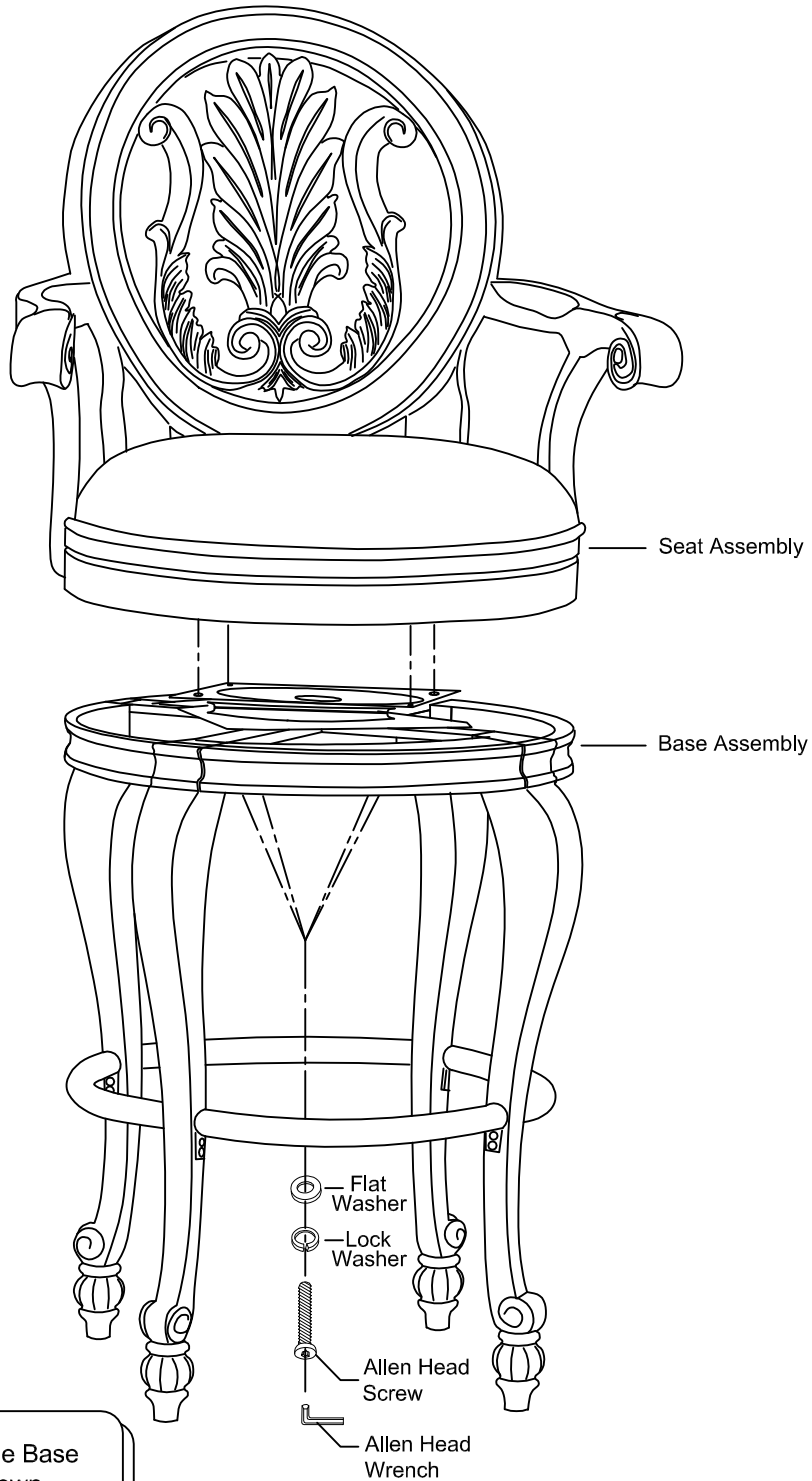





Attach the Seat Assembly to the Base Assembly with hardware as shown.

Periodically check that the screws are tight and secure.

Maximum Weight Capacity = 300 pounds

HARDWARE ENCLOSED

| | | |
|--|-------------------|----------|
|  | Flat Washer | 4 pieces |
|  | Lock Washer | 4 pieces |
|  | Allen Head Screw | 4 pieces |
|  | Allen Head Wrench | 1 piece |