

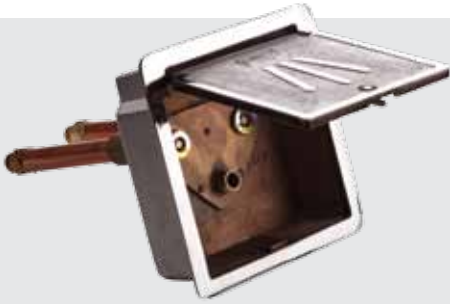

# Commercial Boxed Wall Hydrants

**BRONZE BOX TYPE "TWIN-TEMP"  
NON-FREEZE WALL HYDRANT  
FOR HOT AND COLD WATER**



## FIG. # 5560QT 5560QT (SAP-H-WH)

Twin-Temp Hydrant  
(5560QT-PB Shown)

### FUNCTION:

Provides positive non-freeze protection where water is required at the outside of the building. Ideal for use in food handling areas, dairies and other places where both hot and cold water are desired. The recessed box conceals the hose connection and operating mechanisms. A 1/4 turn of the key allows full flow to be obtained. The locking cover prevents unauthorized use.

### PRODUCT FEATURES:

- Quarter-turn full-flow feature
- 3/4" (19) inlet and hose connection
- Removable "T" handle key
- Recessed installation to eliminate catch points
- Bronze hydrant and box with chrome plated face
- Ideal for use in food handling areas, dairies or other applications that require hot and cold water.
- Replacement parts are available in kit HPRK - 7.

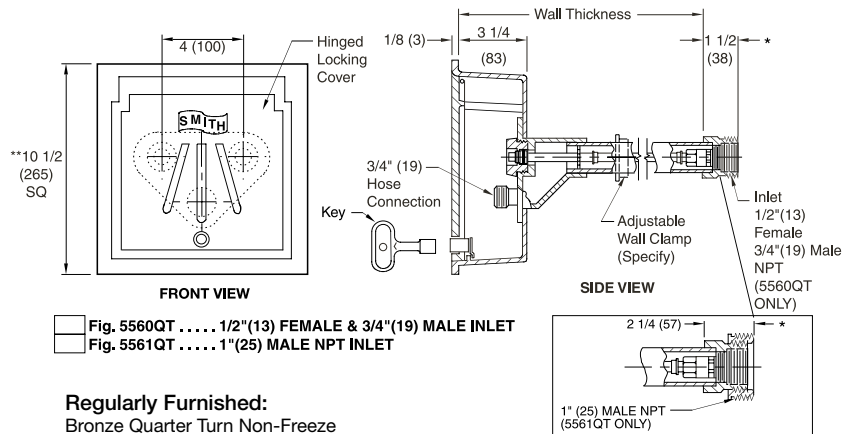

**Regularly Furnished:**  
Bronze Quarter Turn Non-Freeze "Twin-Temp" Hydrant with Hose Connection, "T" Handle Key, and Bronze Box with Chrome Plated Face, and Inlet Size Furnished as Indicated by Figure Number Selected.

- Variations:**
- Adjustable Wall Clamp -WC
  - 1" (25) Hose Connection -HC1
  - 3/4" (19) Vacuum Breaker -H
  - Cylinder Lock -CL
  - "Water" Cast on Cover -W

**NOTE:** Dimensions shown in parentheses are in millimeters.

- Optional Materials:**
- Nickel Bronze Box -NB
  - Polished Bronze Box -PB
  - Rough Bronze Box -RB