

5056BK

CHATEAU 1-LIGHT HANGING LANTERN

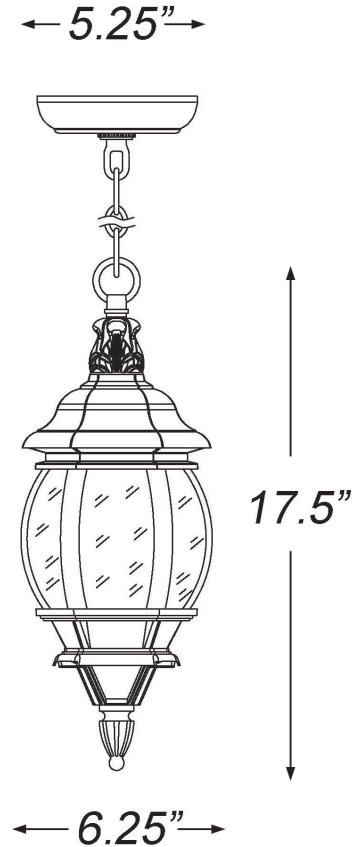

Description:	Chateau 1-light hanging lantern
Finish:	Matte black
Dimensions:	6-1/4" W x 17-1/2" H
Bulbs:	1-100w Med.
Installed Weight:	3.4 lbs.
Certification:	Damp location

Material:	Cast aluminum and glass
Shade:	Glass
Glass:	Clear beveled
Canopy Dimensions:	5-1/4" dia.
Chain/Wire:	5' chain, 10' wire
Additional Finishes:	Textured white