

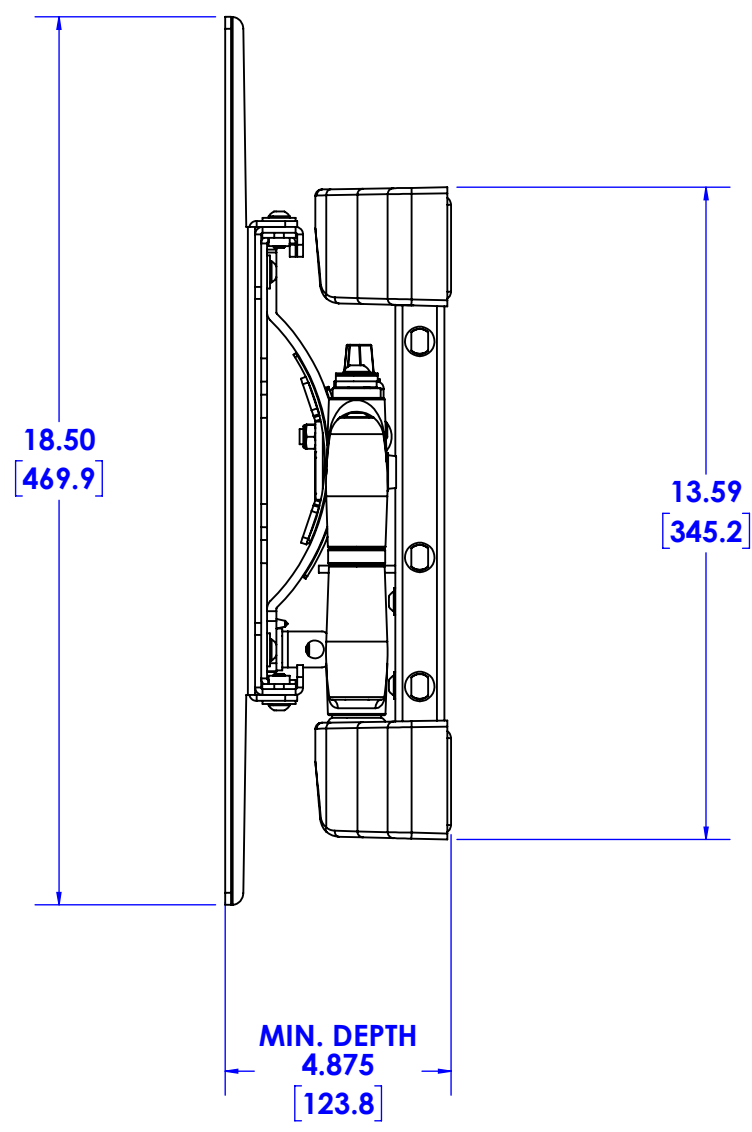

CENTER PLATE INCLUDES 75MM; 100MM & 200 X 100 MM MOUNTING PATTERNS

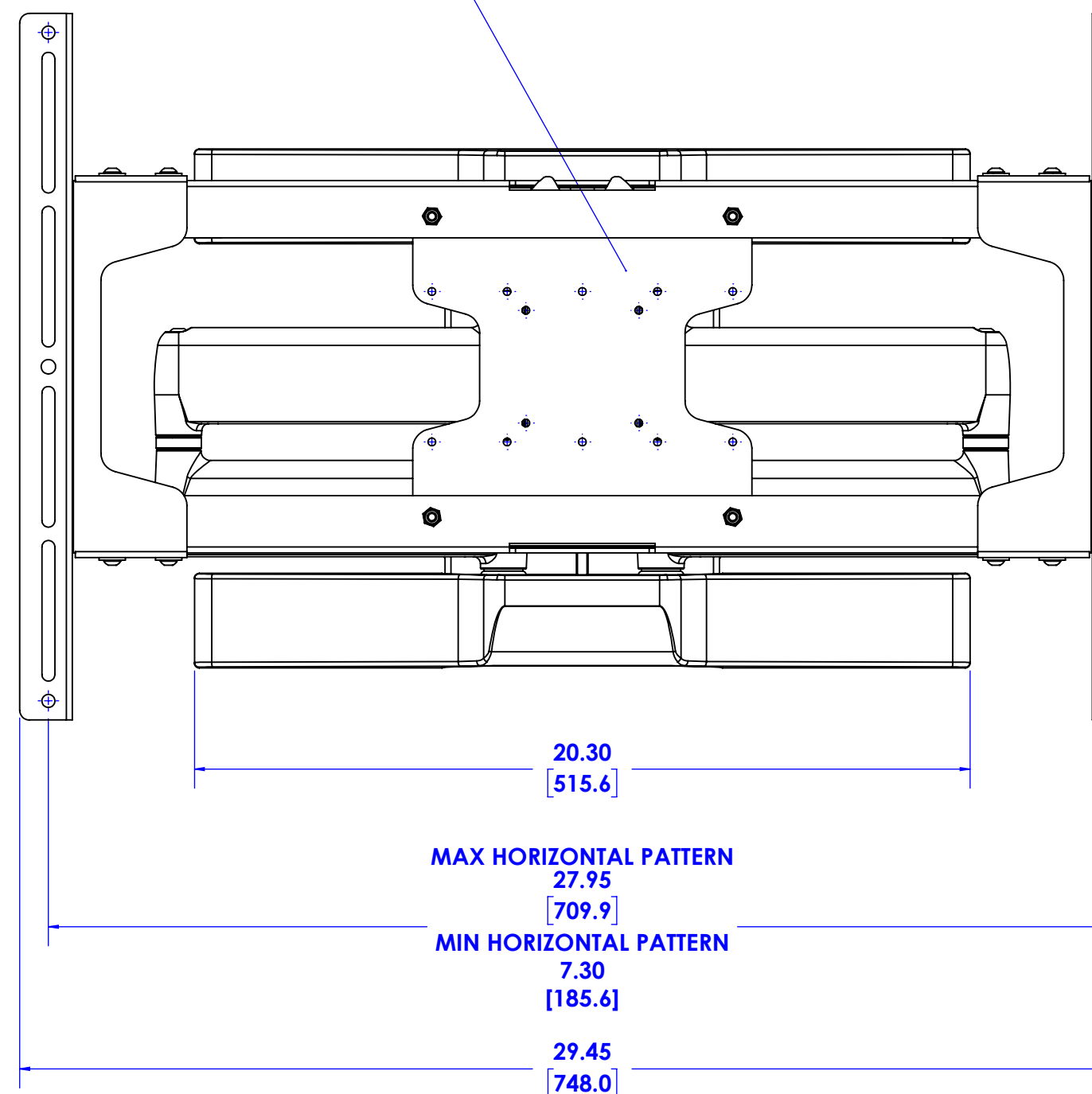

THE INFORMATION AND DESIGNS CONTAINED IN THIS DRAWING ARE CONFIDENTIAL AND THE PROPRIETARY PROPERTY OF MILESTONE AV TECHNOLOGIES NEITHER THIS DESIGN NOR ANY INFORMATION CONTAINED IN THIS DRAWING MAY BE REPRODUCED OR DISCLOSED TO OTHERS WITHOUT THE EXPRESS WRITTEN CONSENT OF MILESTONE AV TECHNOLOGIES.

CAD GENERATED DRAWING, DO NOT MANUALLY UPDATE.				 6436 CITY WEST PKWY EDEN PRAIRIE MN, 55344 PHONE: 866-977-3901 FAX: 877-894-6918	
DRAWN BY	MM	10/23/2015	DESCRIPTION		
ENG APPROVAL			ODM LFP UNIV SWING ARM MNT		
MFG APPROVAL			MODEL NO.		
QA APPROVAL			ODMLA25		
SHEET 1 OF 4		SCALE 1:4	SIZE B	DWG. NO. TECH-000782	REV. 02

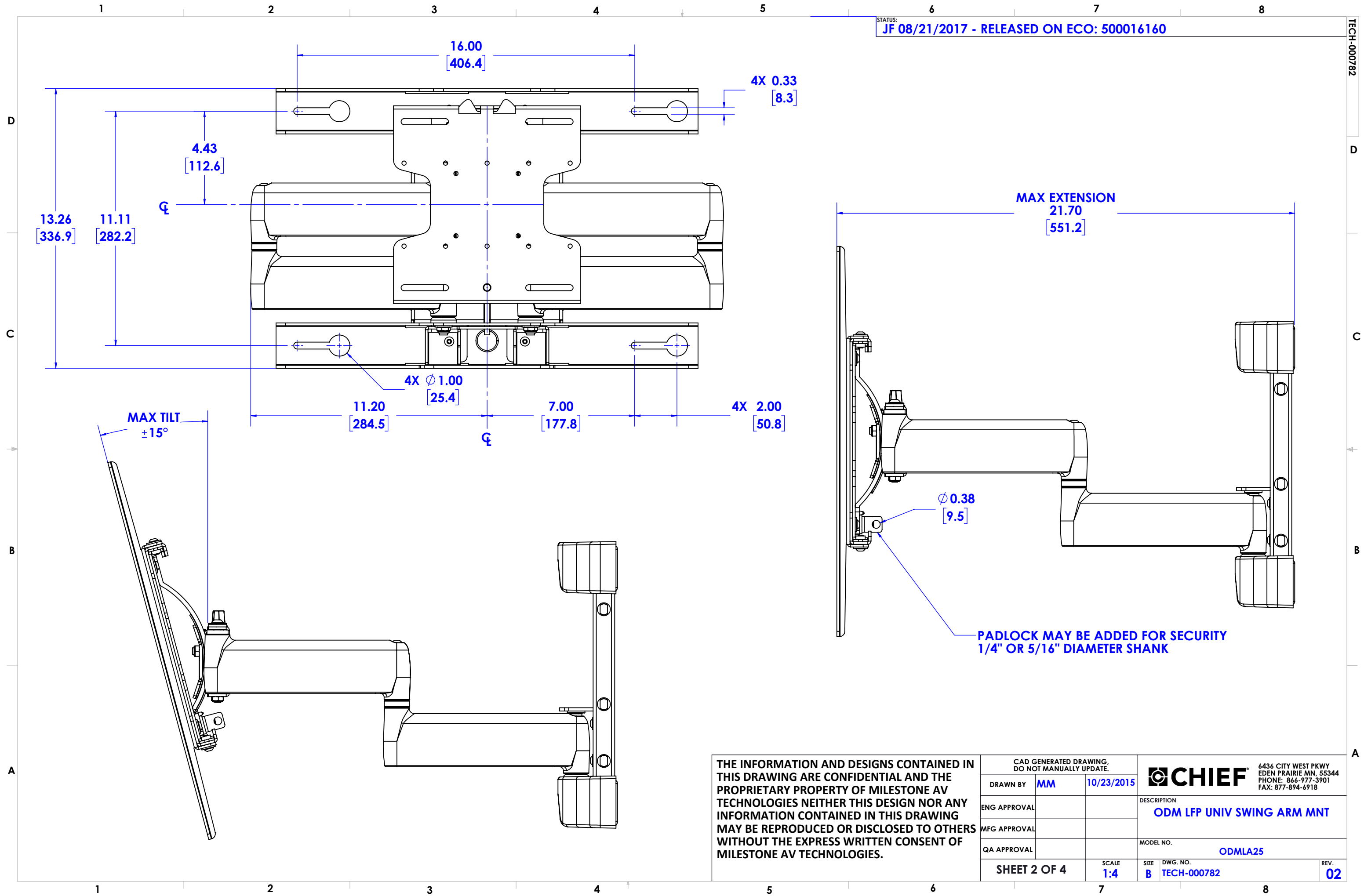

THE INFORMATION AND DESIGNS CONTAINED IN THIS DRAWING ARE CONFIDENTIAL AND THE PROPRIETARY PROPERTY OF MILESTONE AV TECHNOLOGIES NEITHER THIS DESIGN NOR ANY INFORMATION CONTAINED IN THIS DRAWING MAY BE REPRODUCED OR DISCLOSED TO OTHERS WITHOUT THE EXPRESS WRITTEN CONSENT OF MILESTONE AV TECHNOLOGIES.

CAD GENERATED DRAWING, DO NOT MANUALLY UPDATE.		6436 CITY WEST PKWY EDEN PRAIRIE MN, 55344 PHONE: 866-977-3901 FAX: 877-894-6918
DRAWN BY	MM 10/23/2015	
ENG APPROVAL		DESCRIPTION
MFG APPROVAL		ODM LFP UNIV SWING ARM MNT
QA APPROVAL		MODEL NO.
		ODMLA25
SHEET 2 OF 4	SCALE 1:4	SIZE B DWG. NO. TECH-000782
		REV. 02

MAXIMUM SIDE SWIVEL

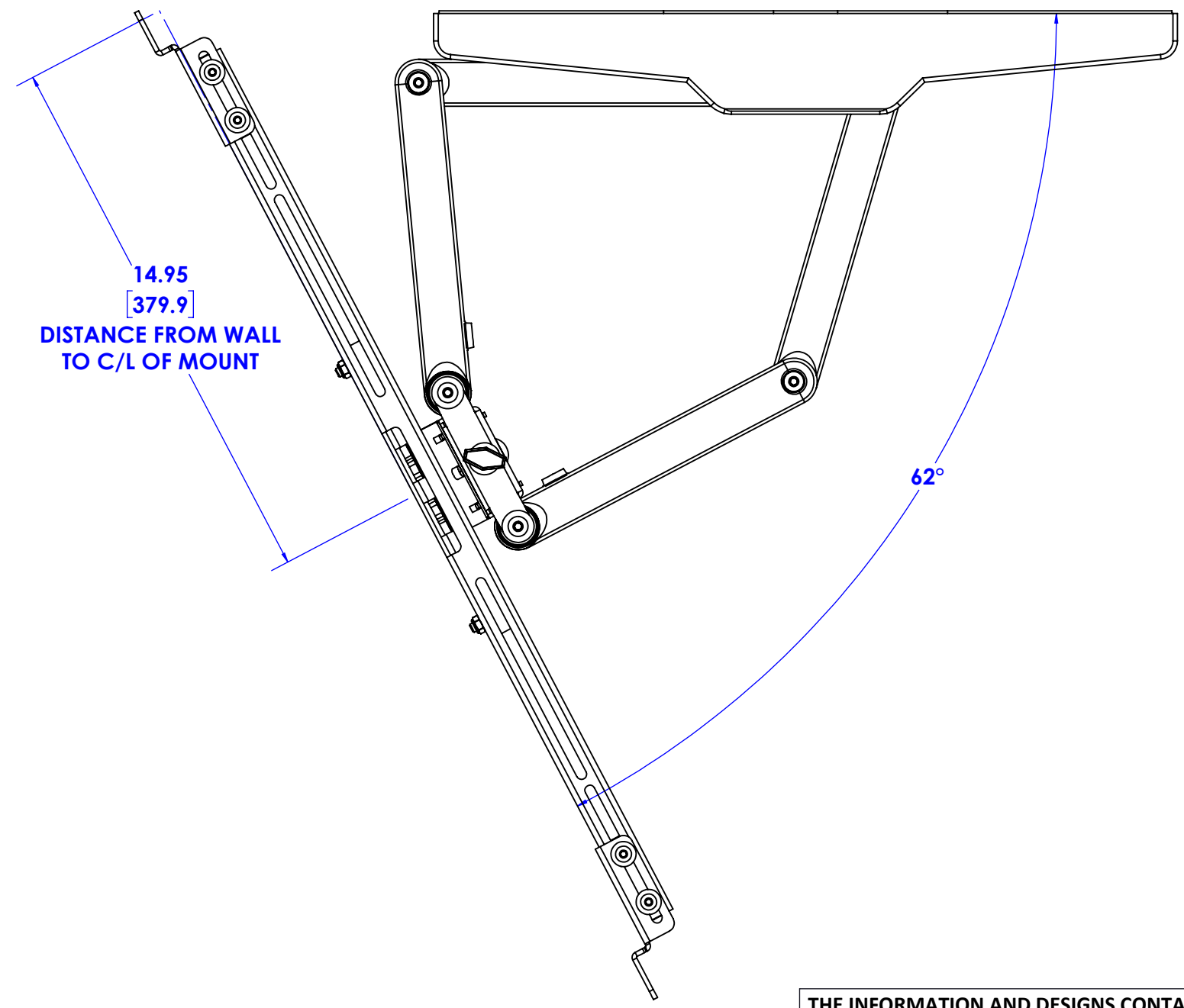

14.95
[379.9]
DISTANCE FROM WALL
TO C/L OF MOUNT

62°

THE INFORMATION AND DESIGNS CONTAINED IN THIS DRAWING ARE CONFIDENTIAL AND THE PROPRIETARY PROPERTY OF MILESTONE AV TECHNOLOGIES NEITHER THIS DESIGN NOR ANY INFORMATION CONTAINED IN THIS DRAWING MAY BE REPRODUCED OR DISCLOSED TO OTHERS WITHOUT THE EXPRESS WRITTEN CONSENT OF MILESTONE AV TECHNOLOGIES.

CAD GENERATED DRAWING, DO NOT MANUALLY UPDATE.			6436 CITY WEST PKWY EDEN PRAIRIE MN, 55344 PHONE: 866-977-3901 FAX: 877-894-6918
DRAWN BY	MM	10/23/2015	
ENG APPROVAL			DESCRIPTION
MFG APPROVAL			ODM LFP UNIV SWING ARM MNT
QA APPROVAL			MODEL NO.
SHEET 3 OF 4			ODMLA25
SCALE	1:4	SIZE	DWG. NO.
		B	TECH-000782
			REV.
			02

MAXIMUM EXTENSION

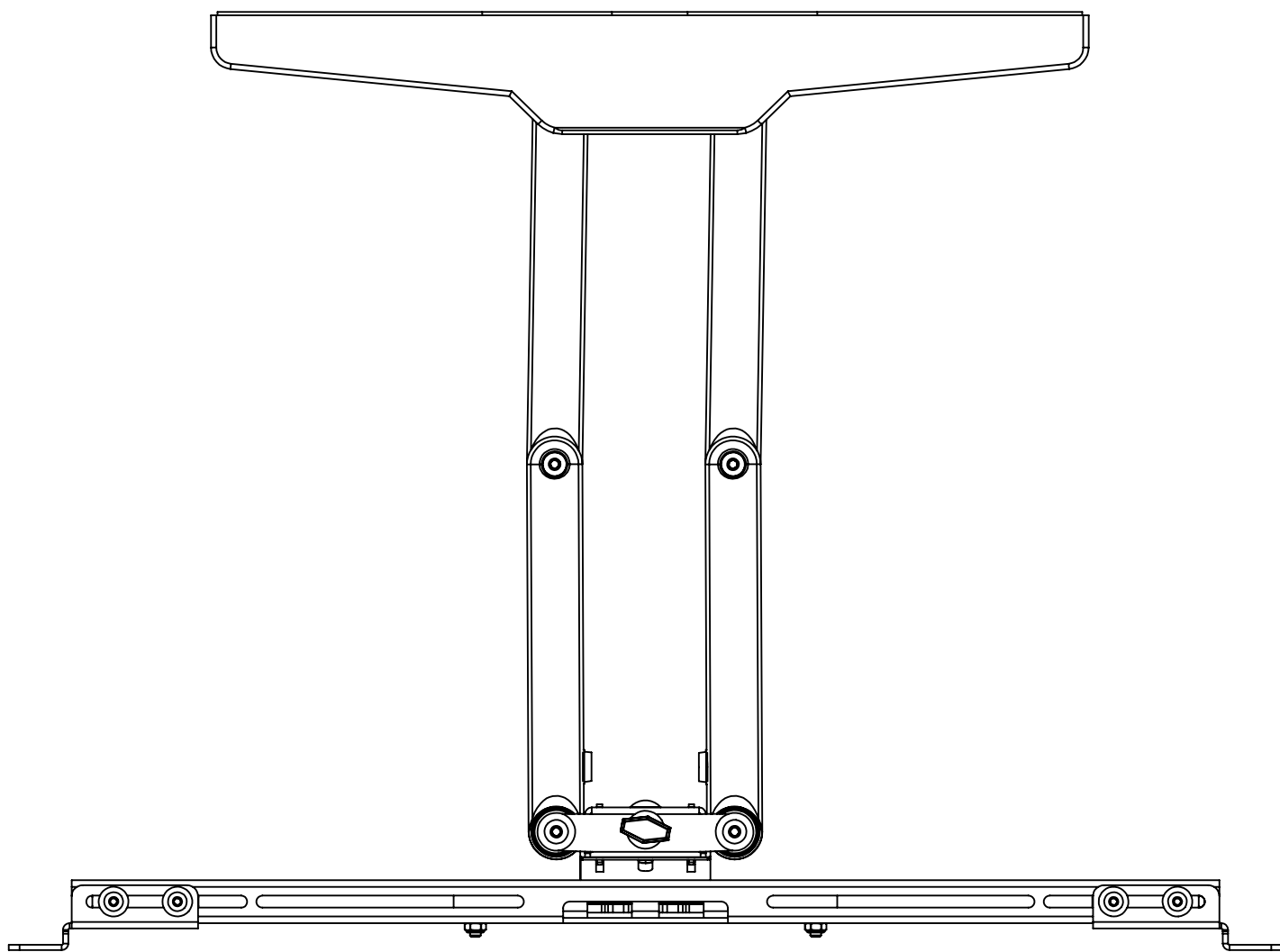

MINIMUM EXTENTION

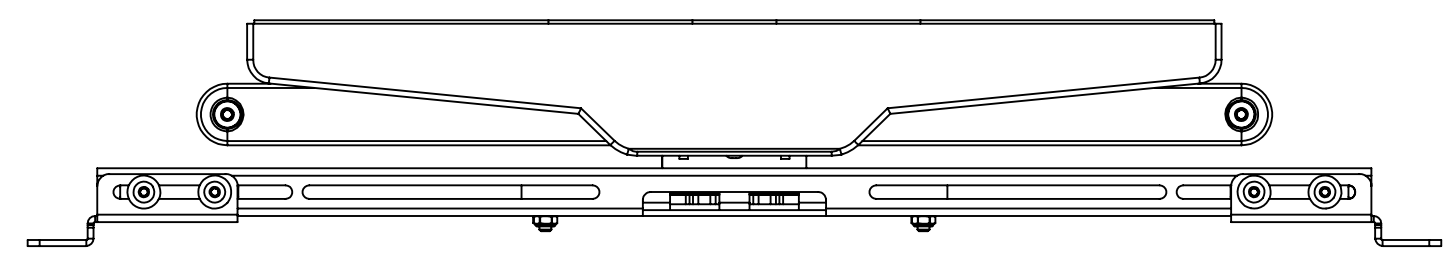

THE INFORMATION AND DESIGNS CONTAINED IN THIS DRAWING ARE CONFIDENTIAL AND THE PROPRIETARY PROPERTY OF MILESTONE AV TECHNOLOGIES NEITHER THIS DESIGN NOR ANY INFORMATION CONTAINED IN THIS DRAWING MAY BE REPRODUCED OR DISCLOSED TO OTHERS WITHOUT THE EXPRESS WRITTEN CONSENT OF MILESTONE AV TECHNOLOGIES.

CAD GENERATED DRAWING, DO NOT MANUALLY UPDATE.			 6436 CITY WEST PKWY EDEN PRAIRIE MN, 55344 PHONE: 866-977-3901 FAX: 877-894-6918
DRAWN BY	MM	10/23/2015	
ENG APPROVAL			DESCRIPTION
MFG APPROVAL			ODM LFP UNIV SWING ARM MNT
QA APPROVAL			MODEL NO.
SHEET 4 OF 4			ODMLA25
SCALE	1:4	SIZE	DWG. NO.
		B	TECH-000782
			REV.
			02