

# BLACK DIAMOND®

Project Name: \_\_\_\_\_

Location: \_\_\_\_\_

Item #: \_\_\_\_\_

Qty: \_\_\_\_\_

## Black Diamond 30 Qt Planetary Mixer, Floor Model, 2.4 HP, Stainless Steel Bowl, in Gray

### BDPM-30



The Black Diamond 30 Quart Planetary Mixer is a versatile piece of equipment ideal for commercial kitchens, bakeries, restaurants, and cafes. Use it for blending batters, whipping cream, making mashed potatoes, preparing dough, creating large batches of sauces, and more. The unit's heavy-duty construction makes it robust enough to handle the rigors of a busy commercial kitchen. Features a stainless steel wire safety guard around the 30-quart bowl and stainless steel bowl clamps.

### FEATURES AND CONSTRUCTION

- Heavy-duty construction withstands demands of commercial kitchens
- 30 qt stainless steel mixing bowl with wire safety guard
- Stainless steel bowl clamps hold mixing bowl securely
- Floor model with rubber foot inserts for stability
- Direct drive, 100% gear-driven transmission for consistent speed
- Three fixed mixing speeds with easy shift
- Push button on/off switch
- Manual 60-minute timer
- Includes wire whisk, dough hook, and flat beater attachments
- #12 attachment hub for meat grinding

### ELECTRIC

120V / 60Hz / 1 ph  
Cord Length (Inches): 60"  
Plug Type: NEMA 5-15P  
Cord set included

NEMA 5-15P



### 3RD PARTY APPROVALS



Intertek



Intertek

### WARRANTY (USA / CANADA)

Protected by Admiral Craft Equipment Corporation's one-year limited warranty.

Contact Admiral Craft Equipment for details at 1-877-672-7740



### CAPACITY

- 30 qt

### INCLUDED COMPONENTS

- Hook, Flat Beater, Wire Whip

BDPM-30

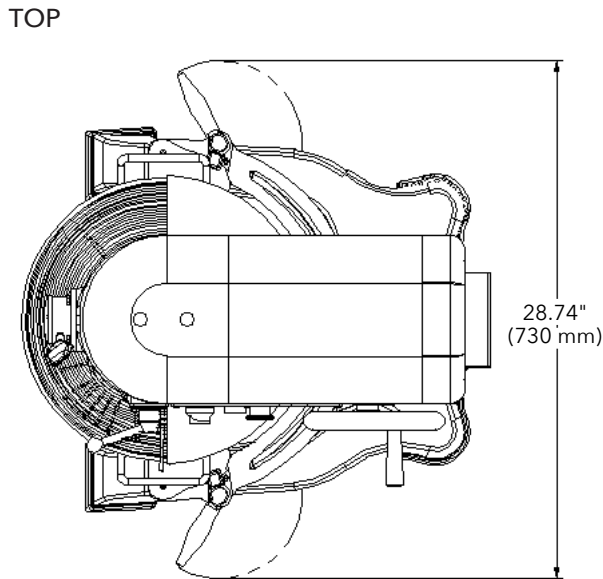
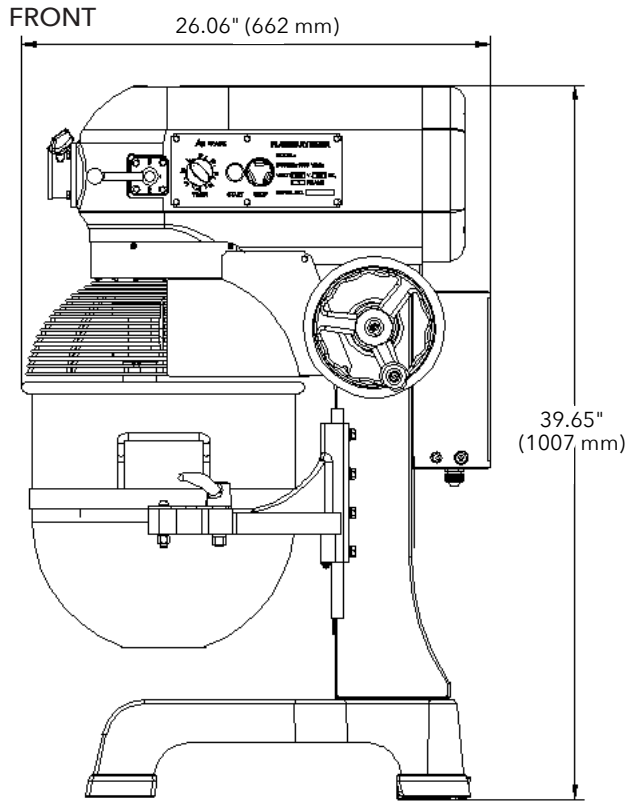

### MIXER CAPACITY CHART

Product	Agitator	Speed	Max Bowl Capacity
Bread and roll dough - 60% AR	Dough hook	1st only	45 lbs
Heavy bread dough - 55% AR	Dough hook	1st only	30 lbs
Pasta Basic Egg Noodle (Max, mix time = 5 min)	Dough hook	1st only	8 lbs
Pizza dough, thin - 40% AR (Max, mix time = 5 min)	Dough hook	1st only	14 lbs
Pizza dough, medium - 50% AR	Dough hook	1st only	20 lbs
Pizza dough, thick - 60% AR	Dough hook	1st only	40 lbs
Raised donut dough - 65% AR	Dough hook	1st and 2nd	15 lbs
Whole wheat dough - 70% AR	Dough hook	1st only	40 lbs
Mashed potatoes	Flat beater	2nd	23 lbs
Mayonnaise (Quarts of Oil)	Flat beater	2nd	12 qts
Waffle or pancake batter	Flat beater	2nd	12 qts
Egg whites	Wire whip	3rd	1.5 qt
Meringue (Qty. of water)	Wire whip	3rd	1 qt
Whipped cream	Wire whip	3rd	6 qts
Cake, Angel Food (8-10 oz. cake)	Wire whip	2nd	22 lbs
Cake, Box or Slab	Flat beater	2nd	30lbs
Cake, Cup	Flat beater	2nd	30lbs
Cake, Layer	Flat beater	2nd	30 lbs
Cake, Pound	Flat beater	2nd	30 lbs
Cake Short (Sponge)	Wire whip	3rd	23 lbs
Cake Sponge	Wire whip	3rd	18 lbs
Cookies, Sugar	Flat beater	2nd	23 lbs
Pie dough	Flat beater	2nd	27 lbs
Eggs & Sugar for Sponge Cake	Flat beater	2nd	12 lbs
Icing, Fondant	Flat beater	2nd	18 lbs
Icing, Marshmallow	Wire whip	2nd	3 lbs
Shorting & Sugar, Creamed	Flat beater	2nd	24 lbs

%AR (% Absorption Ratio) = Water weight divided by flour weight.  
The capacities listed in the chart above are based on flour at room temperature and 70°F water temperature.

30 QUART

### Planetary

Speeds	RPMs	Capacity	Amps	HP	Wattage	Assembled Dimensions (in)	Item Weight (lbs)	Shipping Weight (lbs)
3	84/151/270	30 qt / 28.39 L	16.8	2-2/5	1800W	26.10" x 28.70" x 39.60"	331.0	392.0

Due to periodic changes in designs, methods, procedures, policies and regulations, the specifications contained in this document are subject to change without notice. While we exercise good faith efforts to provide information that is accurate, we are not responsible for errors or omissions in information provided or conclusions reached as a result of using the specifications. By using the information provided, the user assumes all risks in connection with such use.