



Metal leg :
Finished: Matte black powder coated

Specification:

1. Finish: See Table
2. Hardware: See Table
3. Hinge: 700.0537.25 + 600.1234.05 (4 pcs)
4. Slide: USE58-300-18 + USCLIP2ND-4W (3 set)
5. leg levelers (4 pcs)
6. The tolerance is +/- 1/8"

Item number	Finish	Deco Hardware			
		Item number	Qty	Item number	Qty
VN2PAS-42-DW-NT	Dark Walnut	478-192MBBG	2	478-160MBBG	2
VN2PAS-42-GR-NT	Grey	478-192MB	2	478-160MB	2
VN2PAS-42-NO-NT	Natural Oak	478-192MB	2	478-160MB	2
VN2PAS-42-WH-NT	White	478-192MB	2	478-160MB	2

 PROPRIETARY AND CONFIDENTIAL THE INFORMATION CONTAINED IN THIS DRAWING IS THE SOLE PROPERTY OF HARDWARE RESOURCES INC. ANY REPRODUCTION IN PART OR AS A WHOLE WITHOUT THE WRITTEN PERMISSION OF HARDWARE RESOURCES INC. IS PROHIBITED.	ITEM#: VN2PAS-42	MATERIAL:
	FINISH:	WEIGHT: 9
	TOLERANCE UNLESS OTHERWISE SPECIFIED: X ±0.20 X.X ±0.10 X.XX ±0.05 ANGULAR: ±0.5°	PROJECTION  UNITS: DRAWN BY: <i>Hugo.cai</i> DATE: Dec-18-22
	DO NOT SCALE DRAWING	APPROVED BY: RELEASE LEVEL: REVISION:

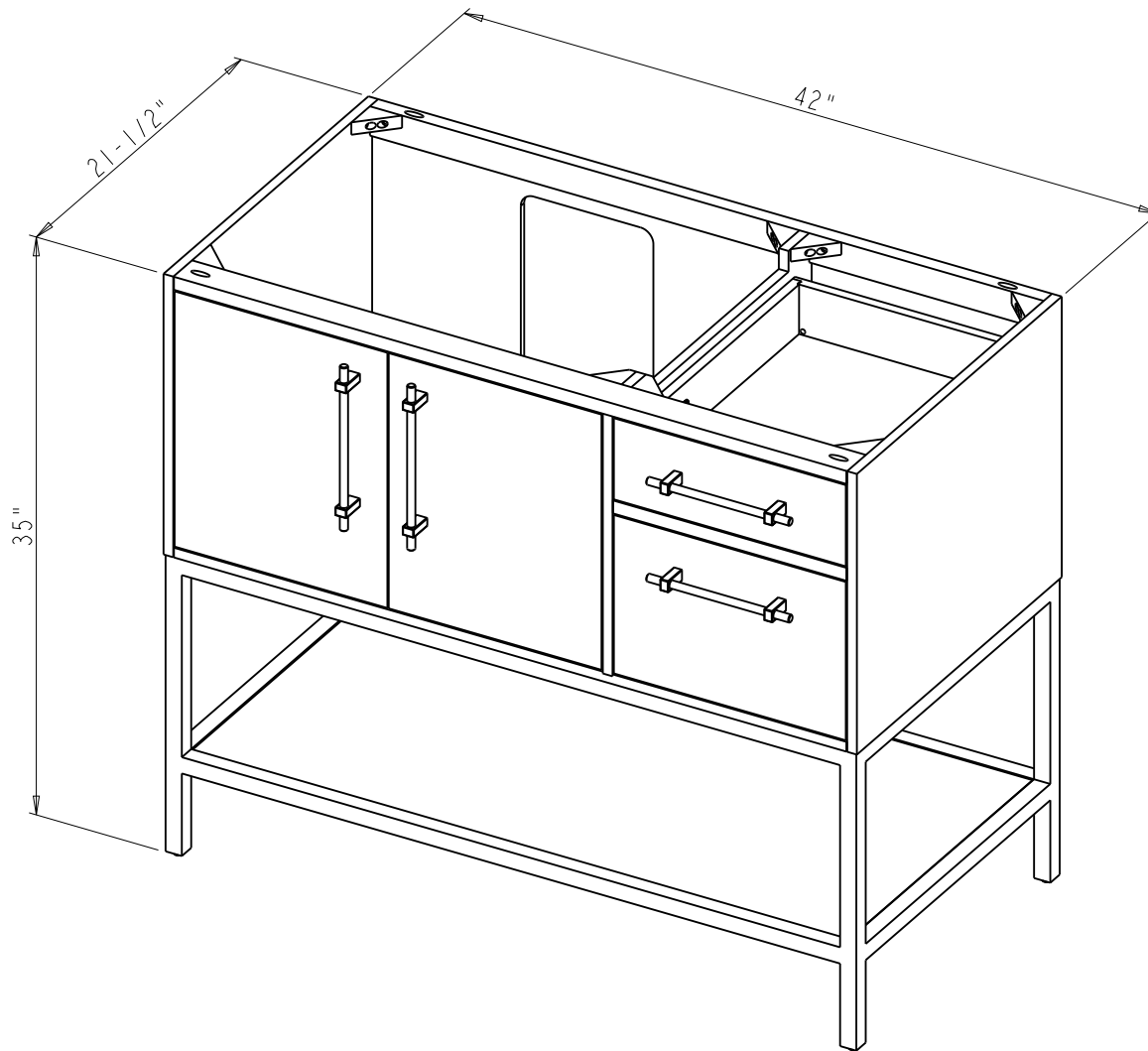

 <p>PROPRIETARY AND CONFIDENTIAL</p> <p>THE INFORMATION CONTAINED IN THIS DRAWING IS THE SOLE PROPERTY OF HARDWARE RESOURCES INC. ANY REPRODUCTION IN PART OR AS A WHOLE WITHOUT THE WRITTEN PERMISSION OF HARDWARE RESOURCES INC. IS PROHIBITED.</p>	ITEM#: VN2PAS - 42		MATERIAL:		
	FINISH:		WEIGHT: 9		
	TOLERANCE UNLESS OTHERWISE SPECIFIED: X ±0.20 X.X ±0.10 X.XX ±0.05 ANGULAR: ±0.5°		UNITS:	DRAWN BY: <i>Hugo.cai</i>	DATE: Dec - 18 - 22
	DO NOT SCALE DRAWING		SIZE:	APPROVED BY:	DATE:
		SHEET:	RELEASE LEVEL:	REVISION:	



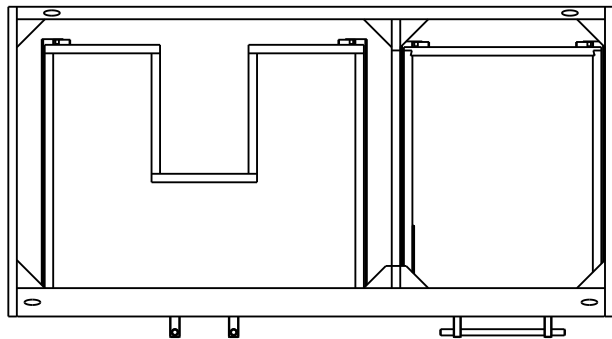
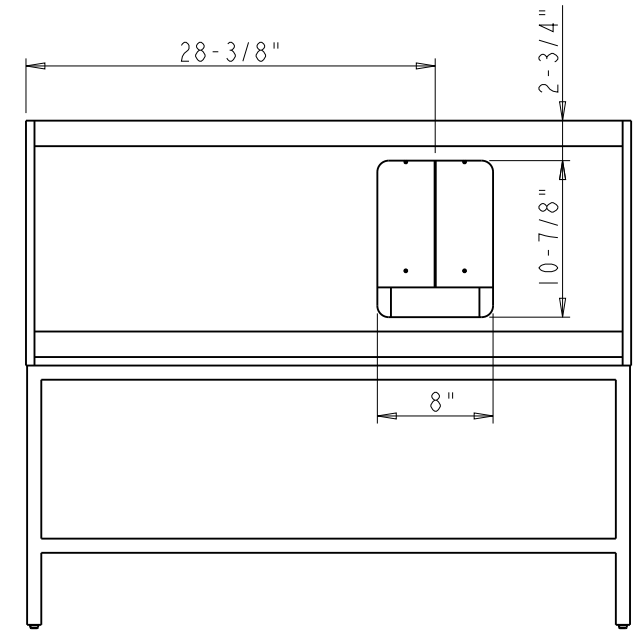
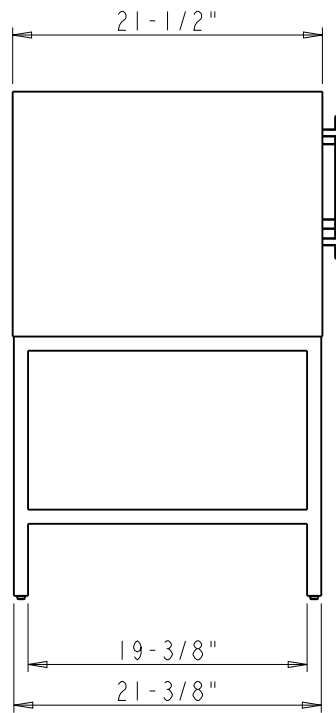
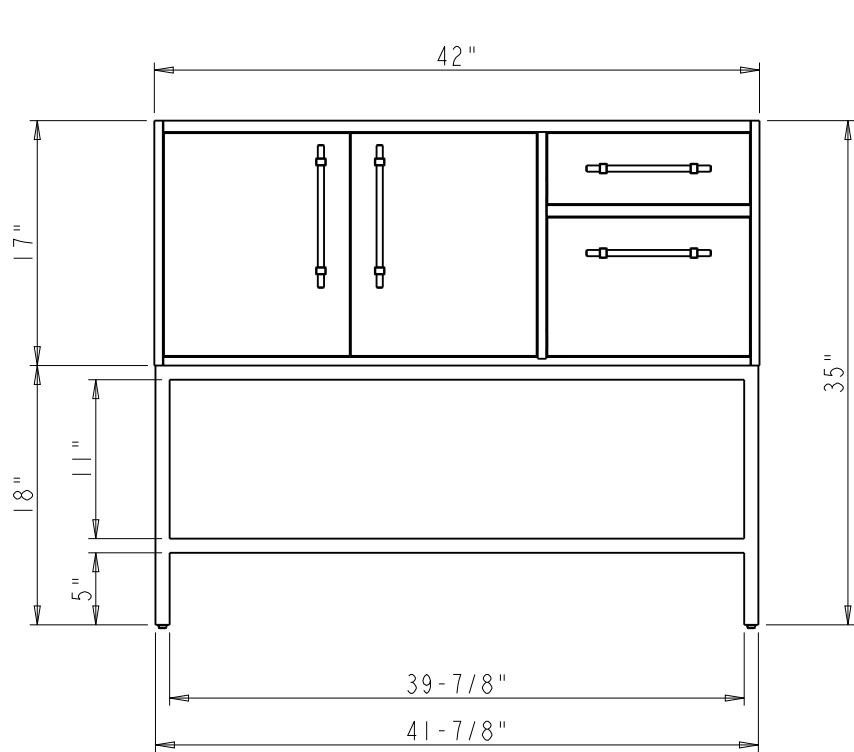

<p>hardware resources</p> <p>PROPRIETARY AND CONFIDENTIAL</p> <p>THE INFORMATION CONTAINED IN THIS DRAWING IS THE SOLE PROPERTY OF HARDWARE RESOURCES INC. ANY REPRODUCTION IN PART OR AS A WHOLE WITHOUT THE WRITTEN PERMISSION OF HARDWARE RESOURCES INC. IS PROHIBITED.</p> <p>DO NOT SCALE DRAWING</p>	ITEM#: VN2PAS-42	MATERIAL:	
	FINISH:	WEIGHT:	
	TOLERANCE UNLESS OTHERWISE SPECIFIED: X ±0.20 X.X ±0.10 X.XX ±0.05 ANGULAR: ±0.5°	UNITS:	DATE: Dec-18-22
	SIZE:	APPROVED BY: <i>Hugo.cai</i>	DATE:
	SHEET:	REVISION:	
	RELEASE LEVEL:		