

The CyberPower logo is displayed in white text on a dark rectangular background in the top left corner of the page.

USER'S MANUAL

Power Management Software

PowerPanel Business Management

Rev. 16

May 2026

SAVE THESE INSTRUCTIONS

Please read this manual and follow the instructions for installation and use.

ELECTRONIC END USER LICENSE AGREEMENT FOR CYBERPOWER POWERPANEL

Please visit <https://www.cyberpower.com/content/software/eula/> to see the complete EULA terms.

Table of Contents

1	Introduction.....	1
2	Getting Started	2
2.1	Prerequisites.....	2
2.1.1	Hardware Limitation.....	2
2.1.2	Operating System.....	2
2.1.3	Web Browser.....	2
2.2	Installation.....	3
2.2.1	Installation on Windows.....	3
2.2.2	Installation on macOS.....	6
2.2.3	Installation on Linux.....	9
2.3	Accessing PowerPanel Business Management.....	14
2.3.1	Login.....	15
3	Using PowerPanel Business Management.....	16
3.1	DASHBOARD	16
3.1.1	Toolbar	16
3.1.2	Node Components	17
3.1.3	Power Device Management.....	20
3.1.4	Power Device Details.....	21
3.1.5	Power Device Operations.....	24

3.1.6	VMware vCenter and ESXi Management.....	26
3.1.7	VMware vCenter and ESXi Details.....	28
3.1.8	Group Management.....	30
3.1.9	Group Details.....	31
3.1.10	Group Operations.....	32
3.2	SETTING.....	35
3.2.1	License Management.....	35
3.2.2	Connection Check.....	35
3.2.3	Network Configurations.....	37
3.2.4	Notifications.....	44
3.2.5	VMware vSphere Shutdown Settings.....	50
3.2.6	Advanced.....	52
3.2.7	Account Management.....	56
3.2.8	Import and Export Configurations.....	58
3.2.9	System Backup.....	58
3.3	REPORTING.....	59
3.3.1	System Logs.....	59
3.3.2	Event Logs.....	59
3.3.3	Energy Use.....	61
3.3.4	Management Card and Firmware Update.....	61
3.4	HELP.....	64
3.4.1	PowerPanel Business.....	64
3.4.2	Check for Updates.....	65
3.4.3	Content.....	65
3.4.4	Operation Log.....	656
3.5	Web Browser Info.....	666
3.5.1	PowerPanel Business Management Installation Location.....	66

3.5.2 Account Information.....	66
3.5.3 Language.....	677
4 Technical Support.....	688
4.1 Troubleshooting.....	688
4.2 FAQ.....	70
5 Glossary.....	777

1 Introduction

PowerPanel Business Management software simultaneously monitors and controls multiple UPS/PDU/ATS units and computers which have Local or Remote (modules from PowerPanel Business) installed via the local network. It also logs events and results about commands for power management.

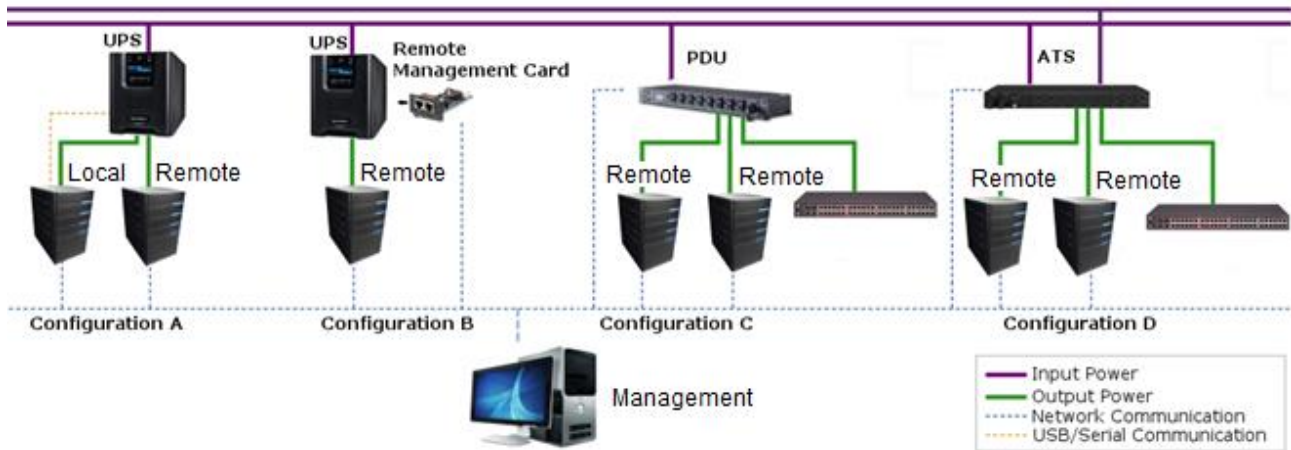

PowerPanel Business structure

PowerPanel Business Management provides users the following functions:

- Simultaneous monitoring of multiple UPS/PDU/ATS units, equipment and computers which have Local or Remote installed.
- Control access to all monitored UPS, PDU, computers and equipment.
- Detailed load management between UPS/PDU/ATS and all powered computers/equipment.
- Equipment groups for easy monitoring or individual access.
- Viewing additional information and status of monitored UPS, PDU, computers and equipment.
- Historical logs for events and results about demands to power management.

2 Getting Started

2.1 Prerequisites

2.1.1 Hardware Limitation

- Minimum Core 2 – Compatible CPU.
- 1 gigabytes (GB) of RAM recommended minimum; more memory generally improves responsiveness.
- Minimum of 1 GB of free space of hard disk.
- Serial port or USB port. (Required by the Local)
- Network interface.

2.1.2 Operating System

PowerPanel Business software can be installed and is supported on the following operating systems:

- **32-Bit Versions:**
 - Windows Server 2025
 - Windows 11
 - CentOS Stream 10
 - CentOS Stream 9
 - Debian 13
 - Ubuntu 24.04 LTS
- **64-Bit Versions:**
 - macOS 26
 - macOS 15
 - CentOS Stream 10
 - CentOS Stream 9
 - Debian 13
 - Ubuntu 24.04 LTS
 - Red Hat Enterprise 10
 - VMware ESXi 8.0 U2 (ESXi Free Edition is not supported)
 - VMware vCenter 8.0

Note: Because of the abundance of different Linux builds, not all builds are tested with PowerPanel Business but most builds will be able to run the program.

2.1.3 Web Browser

PowerPanel Business software is accessed using a web browser and is compatible with the following browsers:

- Microsoft Edge
- Firefox
- Google Chrome
- Safari

2.2 Installation

2.2.1 Installation on Windows

After you have downloaded PowerPanel Business from CyberPower Systems' website (www.cyberpower.com) follow the setup installation wizard as described below:

- Click the **Next** button to start an installation.

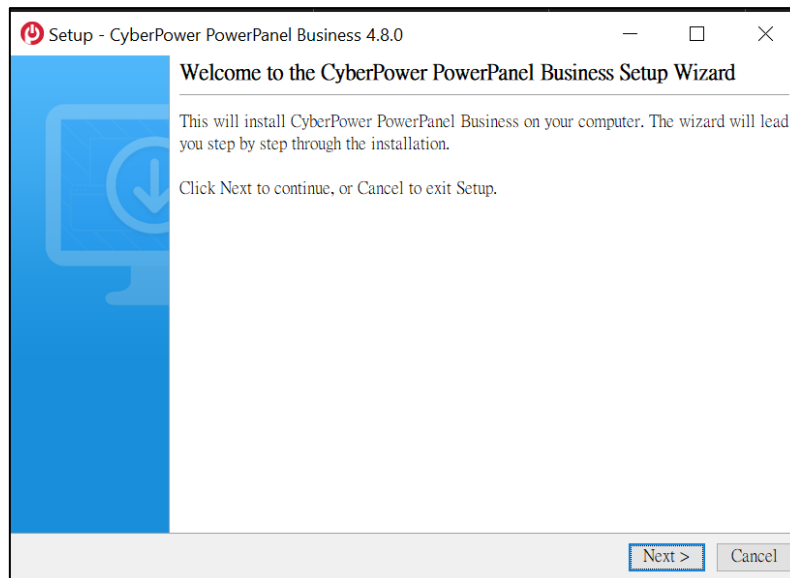

- Accept the license agreement.

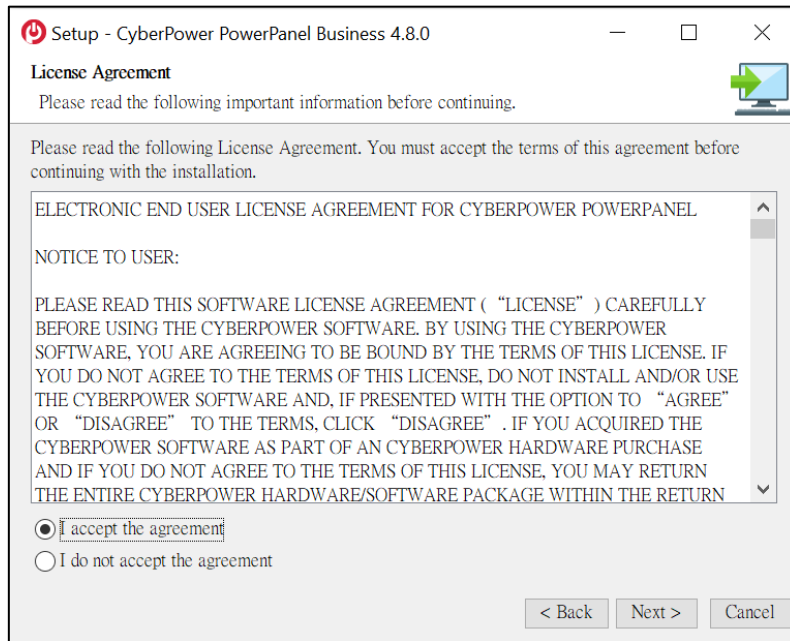

- Select the destination directory.

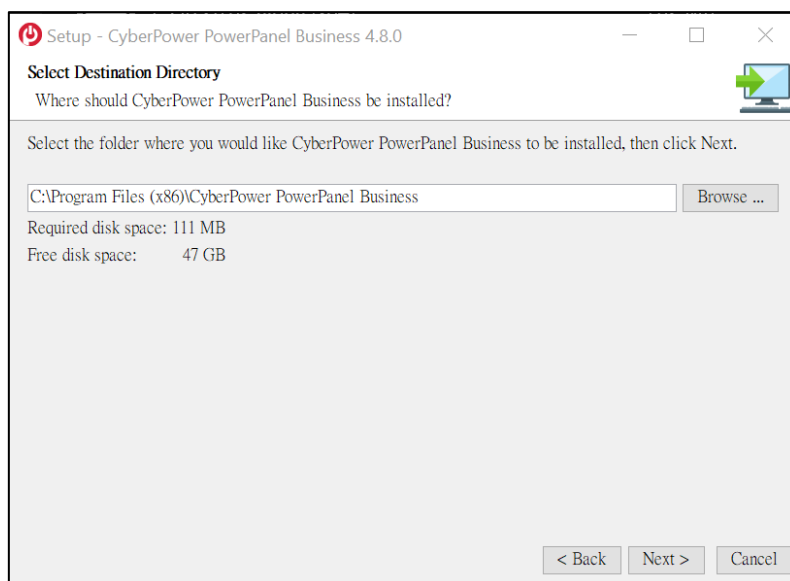

- Choose the component. PowerPanel Business Management only contains one module. In this step, only Management can be selected.

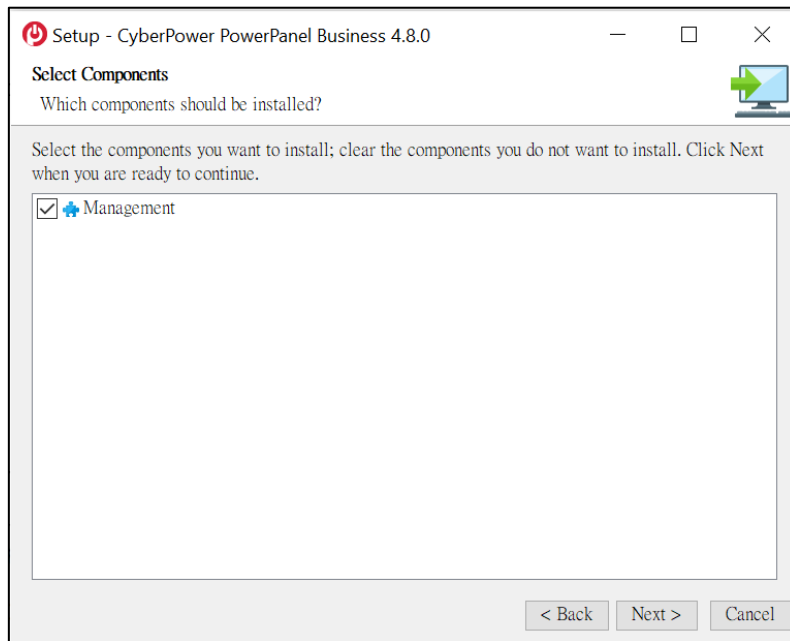

- Wait for PowerPanel Business Management to be installed.

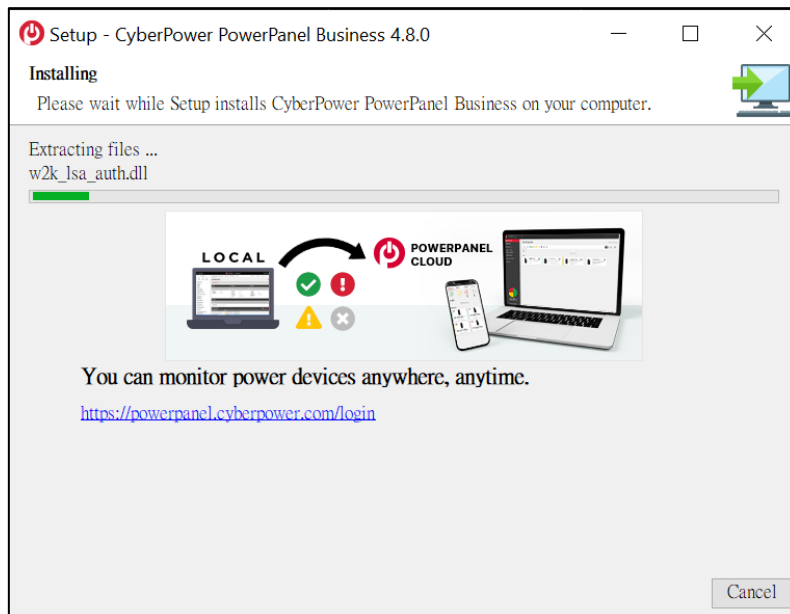

- Click the **Finish** button to complete the installation.

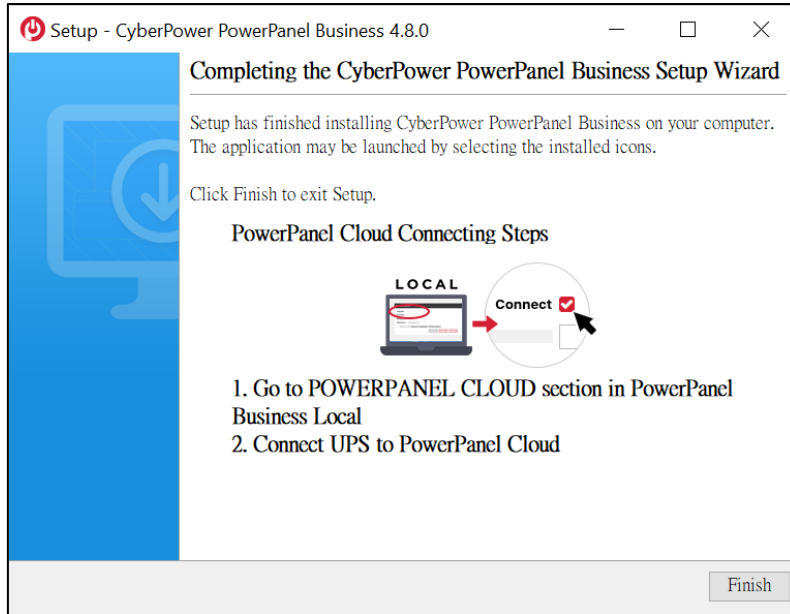

2.2.2 Installation on macOS

After you have downloaded PowerPanel Business from CyberPower Systems' website (www.cyberpower.com) follow the setup installation wizard as described below:

- Click the **Next** button to start an installation.

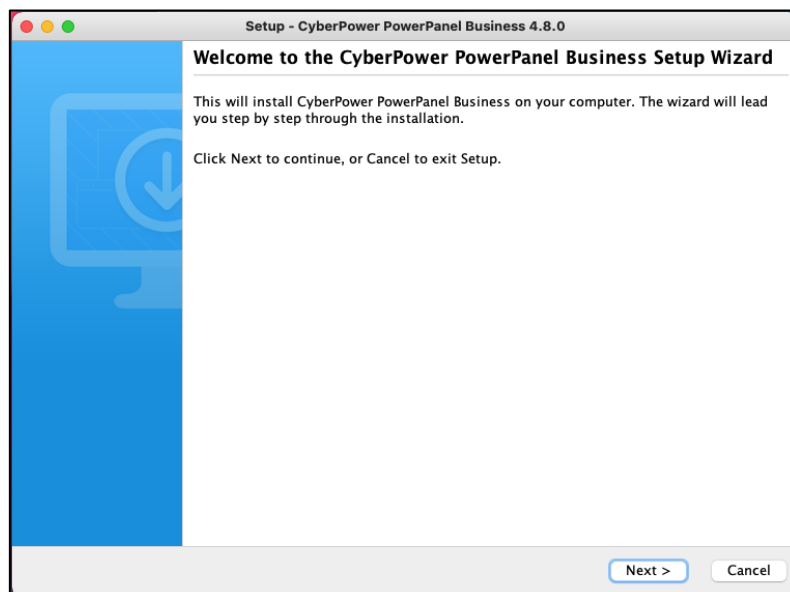

- Accept the license agreement.

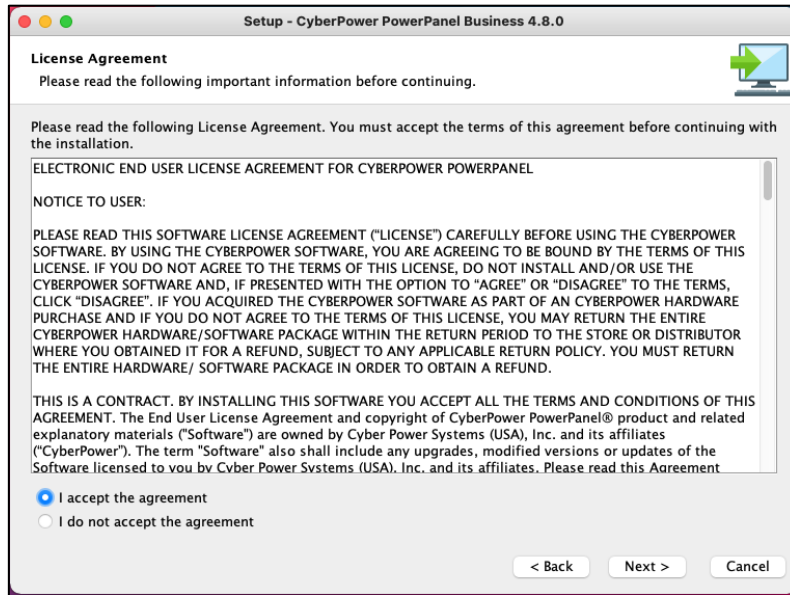

- Select the destination directory.

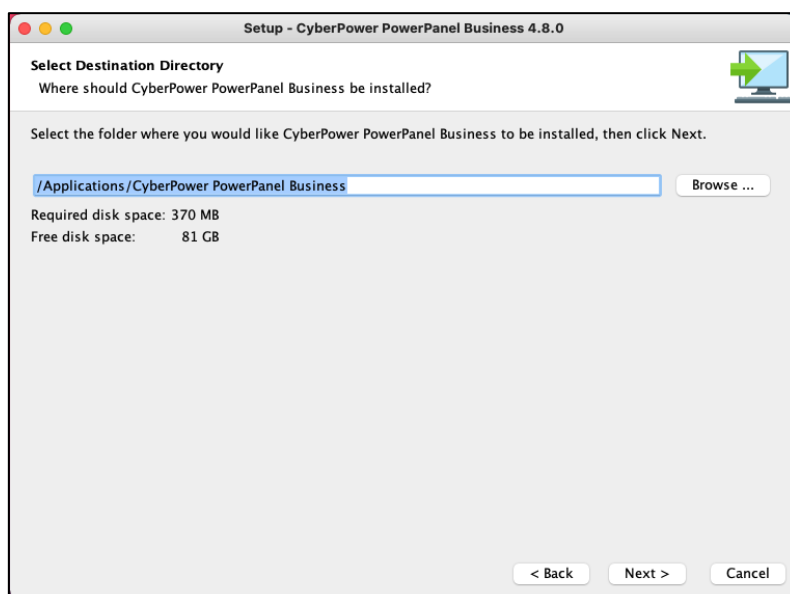

- Choose the component. PowerPanel Business Management only contains one module. In this step, only Management can be selected.



- Wait for PowerPanel Business Management to be installed.

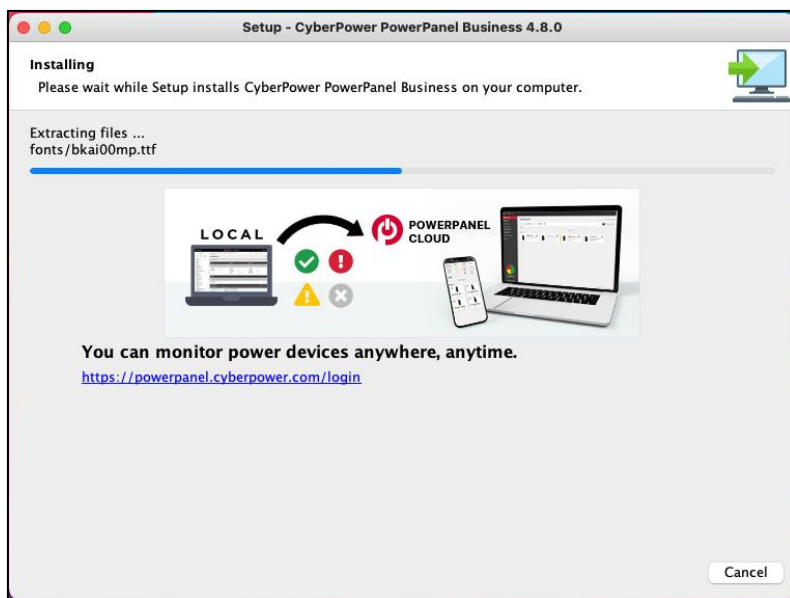

- Click the **Finish** button to complete the installation.

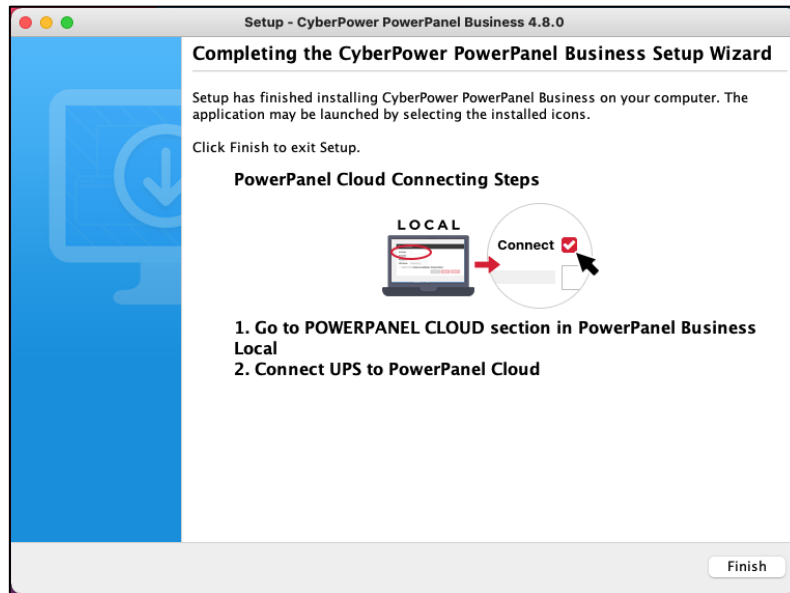

2.2.3 Installation on Linux

After you have downloaded Business from CyberPower Systems' website (www.cyberpower.com) follow the setup installation wizard as described below. The installer is used to install the software and requires root permission. The installation wizard will guide users in completing the installation. Initiate the wizard by running the `./ppb-linux-x86.sh` command or double clicking `ppb-linux-x86.sh` on 32-bit systems or by running the `./ppb-linux-x86_64.sh` command or double clicking `ppb-linux-x86_64.sh` on 64-bit systems.

To install, follow below steps:

- Click the **Next** button to start an installation.

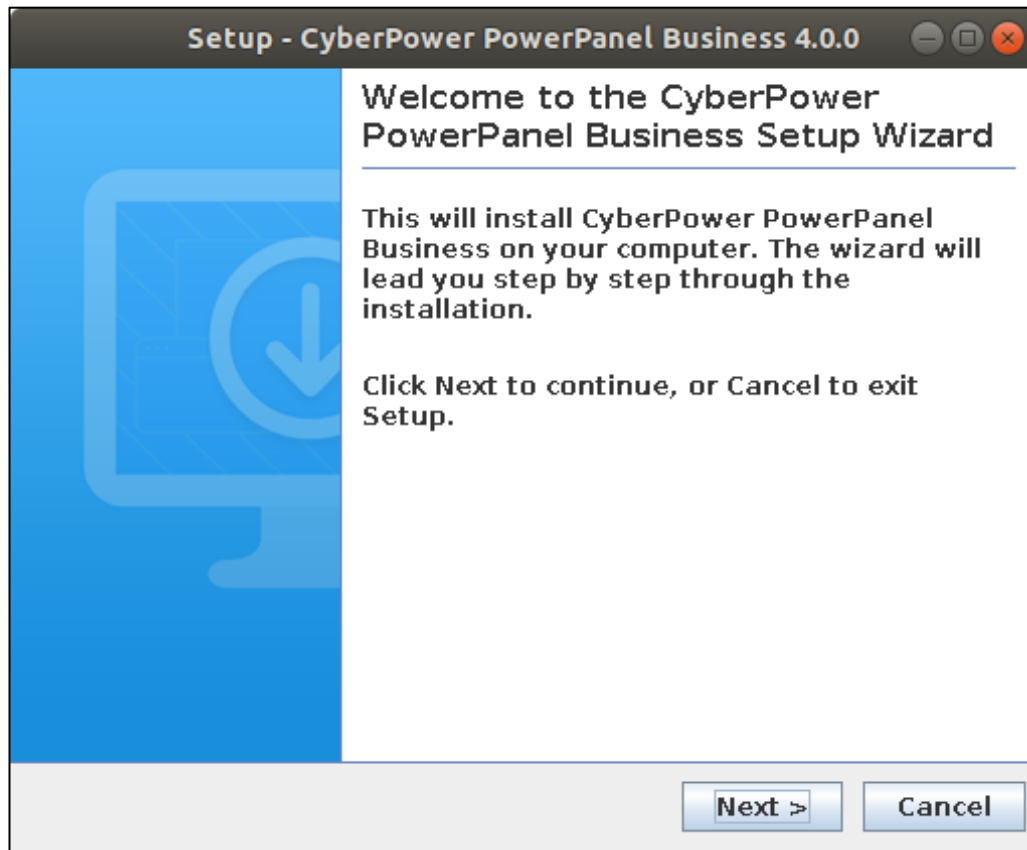

- Accept the license agreement.

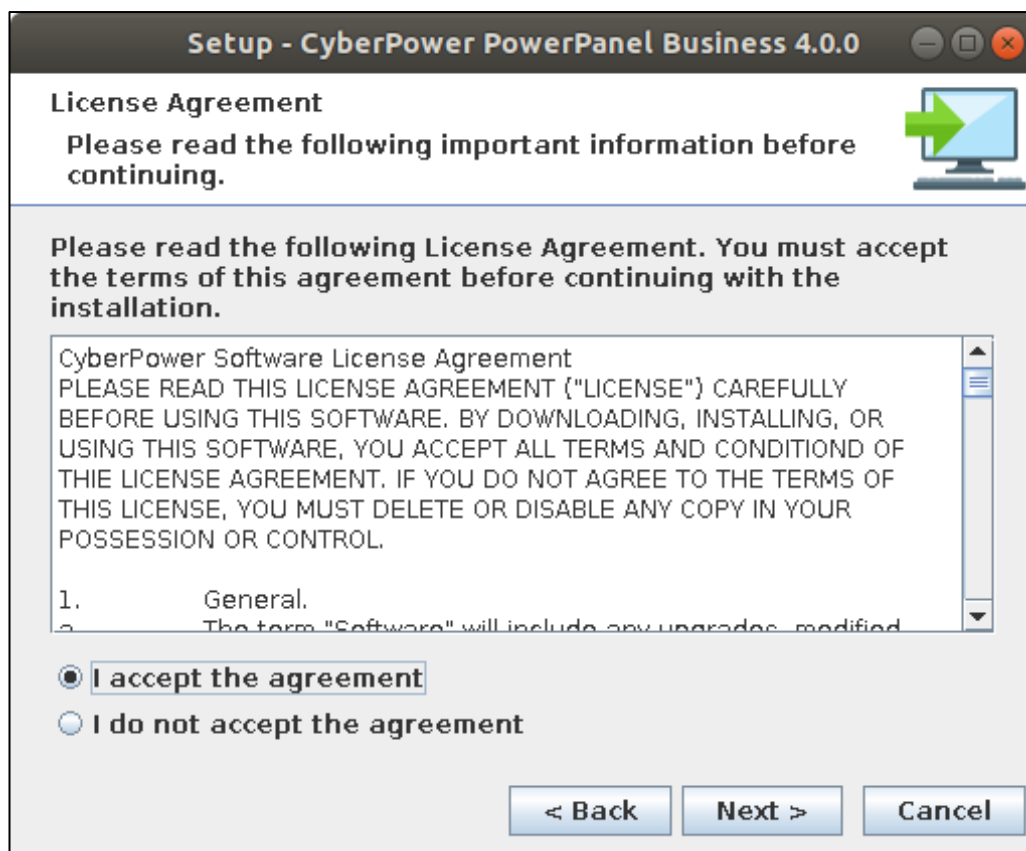

- Choose the destination directory.

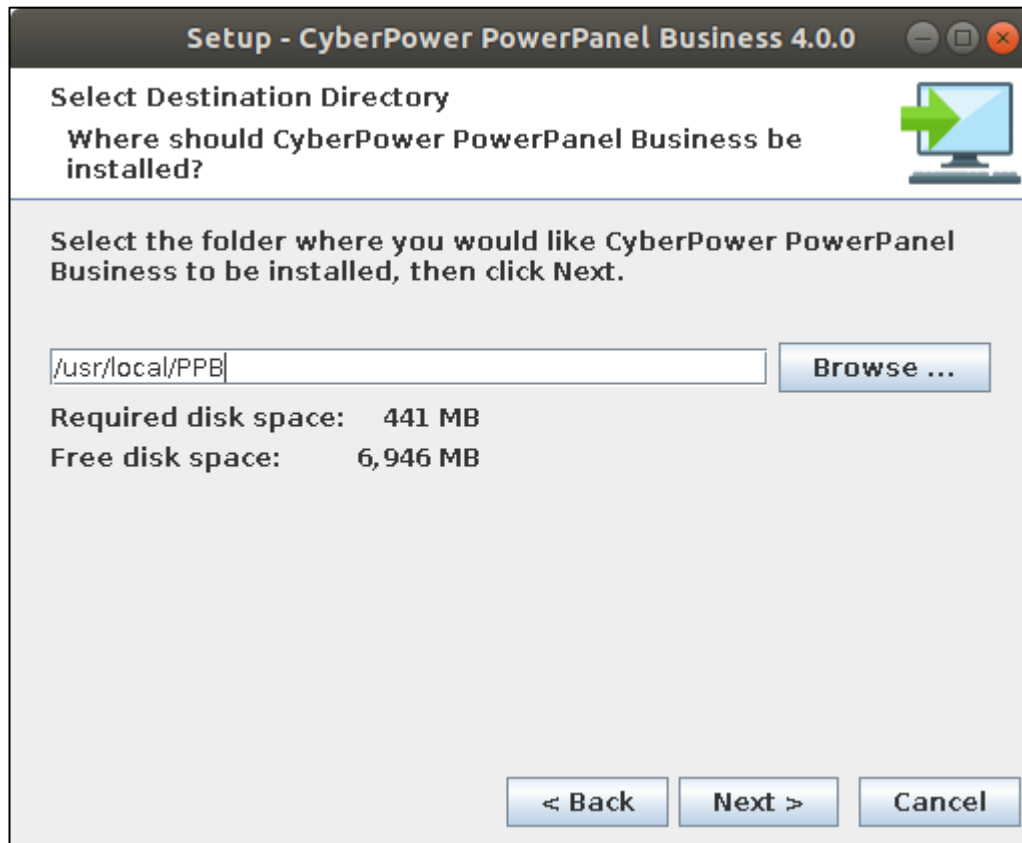

- Choose the component. PowerPanel Business Management only contains one module. In this step, only Management can be selected.

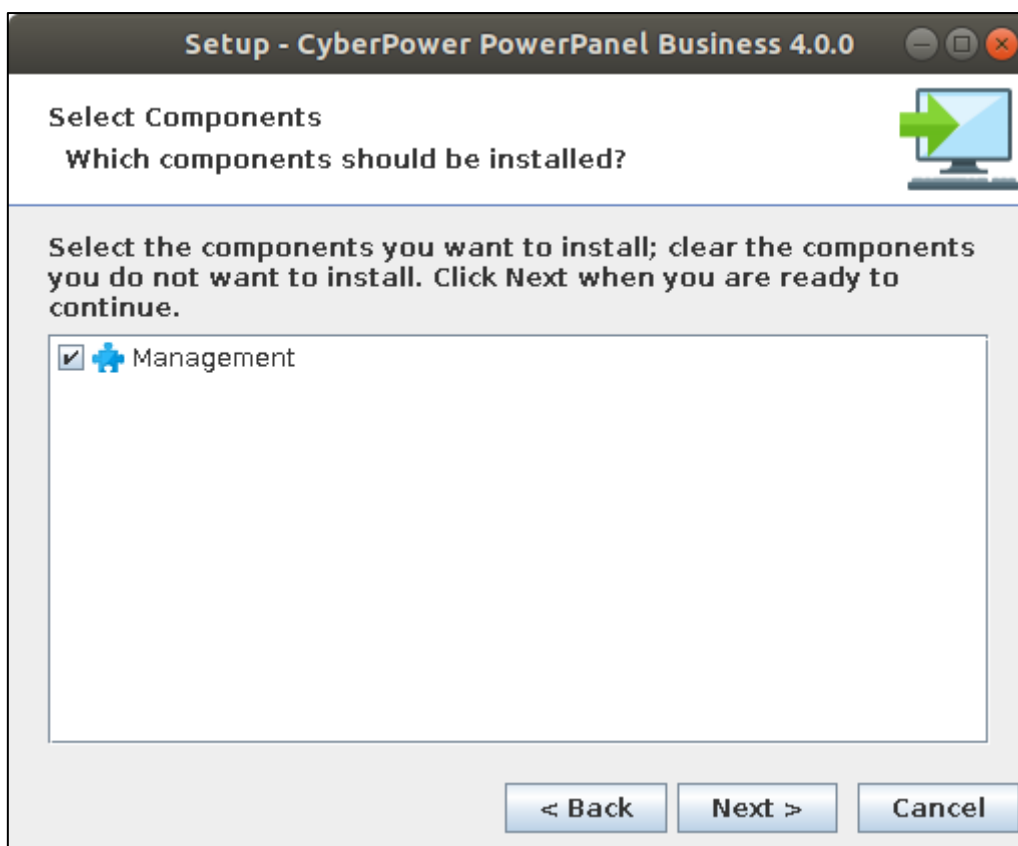

- Click the **Finish** button to complete the installation.

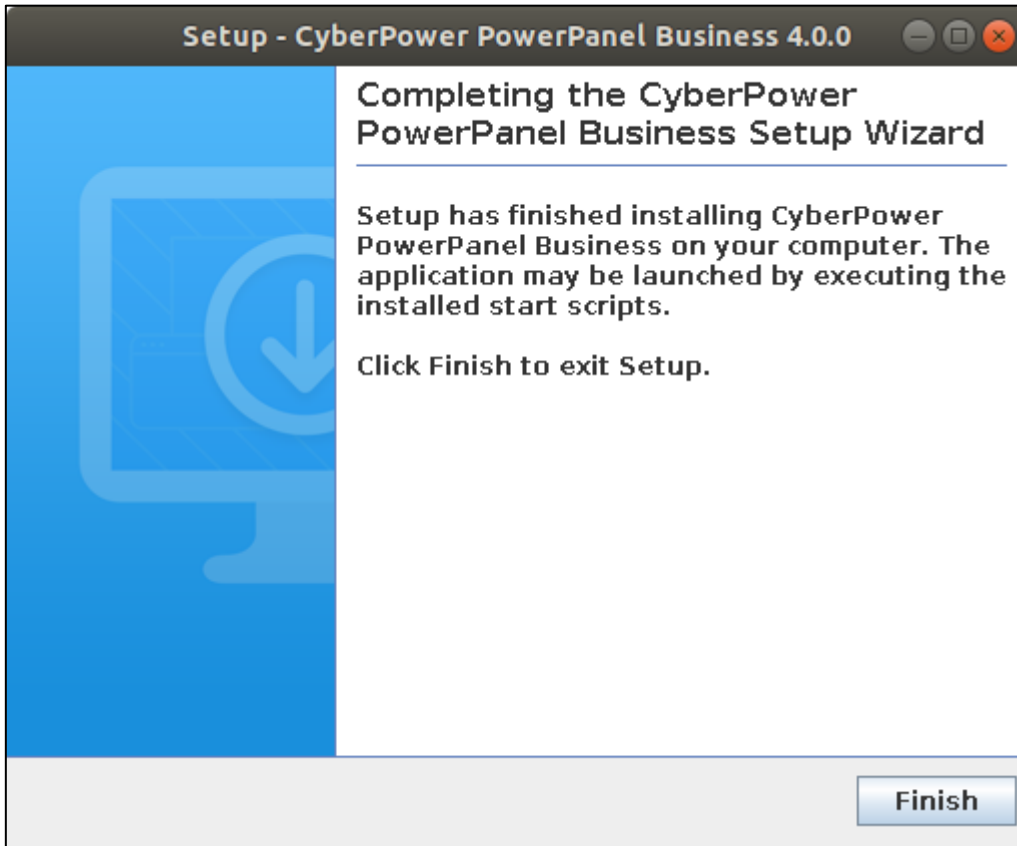

2.2.3.1 Installation in Text Mode

When the system does not support graphic mode, the Linux installation needs to be initiated in the terminal by using the `./ppb-linux-x86.sh -c` command on 32-bit systems or use `./ppb-linux-x86_64.sh -c` command on 64-bit systems.

The installation procedure will be initiated as following steps:

- Press **Enter** to start an installation.

```
Unpacking JRE ...
Starting Installer ...
This will install CyberPower PowerPanel Business on your computer.
OK [o, Enter], Cancel [c]
```

- Accept the license agreement.

```
of law rules. You irrevocably agree to the exclusive jurisdiction and venue
of the courts in Paris, France for any disputes arising out of or in
connection with this License. If applicable law prevents jurisdiction and
venue in Paris, then to the maximum extent permitted by applicable law you
irrevocably agree that for any disputes arising out of or relating to this
License exclusive jurisdiction and venue will be in the courts in the
largest city in your country within 200 miles of where you live.
```

```
c. Outside the United States and Europe. If you acquired the Software in any
country other than in North America, South America or Europe, this License
will be governed by the laws of Taiwan and the court of first instance will
be Taiwan Shilin District Court, excluding the application of its conflicts
of law rules. If applicable law prevents the designation of the Taiwan
Shilin District Court as the court of first instance, then to the maximum
extent permitted by applicable law you irrevocably agree that for any
disputes arising out of or relating to this License exclusive jurisdiction
and venue will be in the courts in the largest city in your country within
200 miles of where you live.
```

```
13. Others.
[Enter]
```

```
a. If any part of this License is found void and unenforceable under
applicable laws, it will not affect the validity of the rest of the License,
which shall remain valid and enforceable according to its terms. This
License shall automatically terminate upon failure by you to comply with its
terms. This License may only be modified in writing signed by an authorized
officer of Cyber Power Systems, Inc.
```

```
b. These terms expressly supersede prior agreements or arrangements with
you. We may amend the Terms from time to time. Amendments will be effective
upon Cyber Power Systems, Inc. posting of such updated terms at this
location or in the amended policies or supplemental terms on the applicable
Software(s). Your continued access or use of the Software after such posting
confirms your consent to be bound by the Terms, as amended.
```

```
I accept the agreement
Yes [1], No [2]
```

- Choose the destination location.

```
Select the folder where you would like CyberPower PowerPanel Business to be
installed, then click Next.
Where should CyberPower PowerPanel Business be installed?
[/usr/local/PPB]
```

- Choose the component. If one single computer is connected to the UPS directly via a USB or serial connection, Local should be installed. If the computer is powered by a UPS already connected to a Local, has a remote management card installed or is connected to a PDU, Remote should be installed.

Note: Local and Remote cannot be installed on the same computer.

```
Which components should be installed?
1: Local
2: Remote
Please enter a comma-separated list of the selected values or [Enter] for the default selection:
1
```

- Installation procedure starts to process until the installation is complete.

```
Extracting files ...
ling CyberPower PowerPanel Business on your
computer.
Finishing installation ...
Setup has finished instal
```

2.3 Accessing PowerPanel Business Management

The PowerPanel Business Management web interface can be accessed following the directions below. To access the web interface on a local computer, select **Start > All Programs > CyberPower PowerPanel Business > PowerPanel Business Management** in the Windows Desktop or enter the **http://localhost:3052/management** as the URL in the browser.

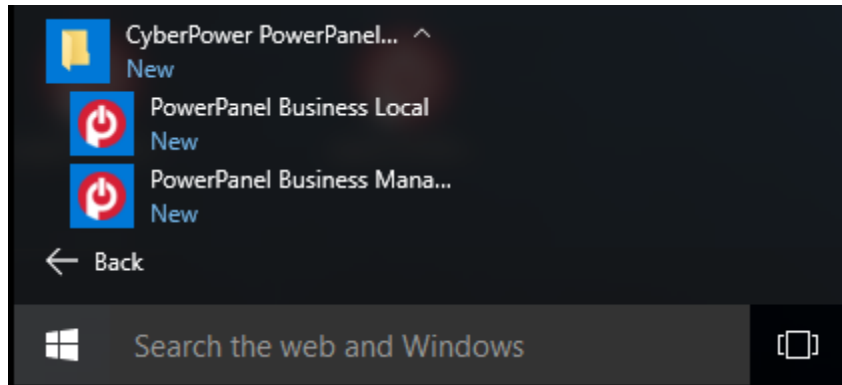

Launching PowerPanel Business software

On Linux, users can enter **http://localhost:3052/management** in the address of the web browser to access the interface. Users can also enter the URL, **http://localhost:3052/management** in the local computer or **http://hosted_computer_ip_address:3052/management** in the remote computer, to the address field of the web browser to access the PowerPanel Business software web interface. **hosted_computer_ip_address** is the IP address of the computer which has the PowerPanel Business software installed. For vMA on the ESX or ESXi, **hosted_computer_ip_address** is the IP address of the vMA (**Note: hosted_computer_ip_address** is the IP address of the host computer on ESX).

2.3.1 Login

The default username is **admin** and the password is **admin**. For security, it is recommended to change the username and password on the **SETTING/Account Management** page after the initial login.

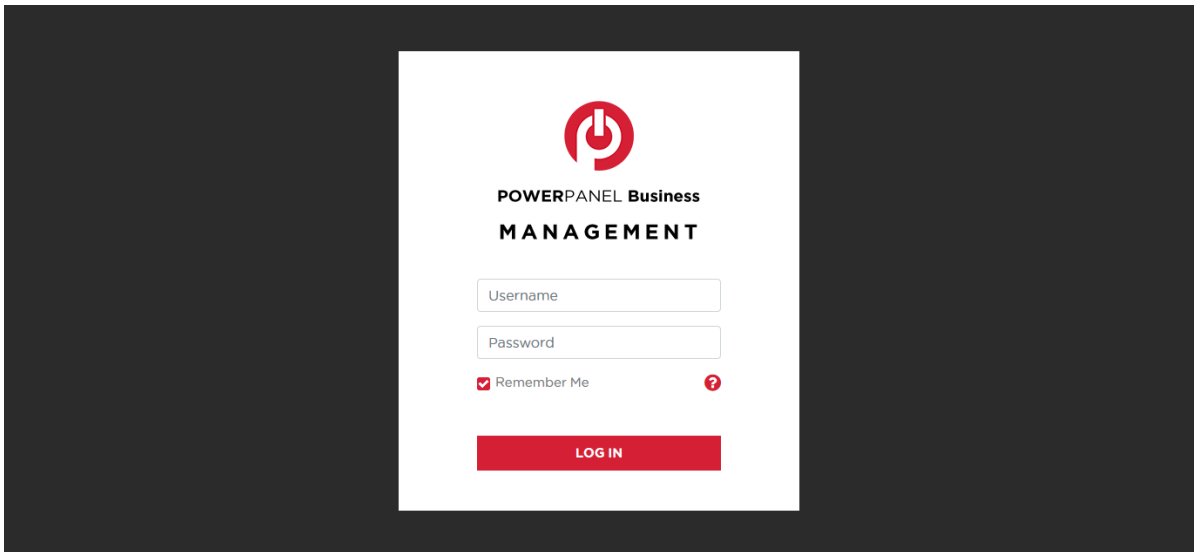

The login page

Selecting the **Remember Me** option on the login page allows the credentials to be remembered for automatic logon at the next session. To terminate the session, click the **Logout** button on the page. The session will timeout and you will be logged out if no activity takes place during the time of **Session Timeout**. The **Session Timeout** can be configured on the **SETTING/Account Management** page.

3 Using PowerPanel Business Management

3.1 DASHBOARD

DASHBOARD page provides the management of power equipment and VMware nodes. Below are the capabilities user can find in **DASHBOARD** page.

- Monitor status and events from a connected UPS/PDU/ATS.
- Issue commands to the UPS/PDU/ATSs such as a power off, power cycle or power restore.
- Request that the UPS perform a battery test, sound its alarm or mute the audible alarms.
- Manage equipment and computers which are powered by UPS units and PDUs, and order connected computers to shut down or a reboot.
- Manage grouped UPS/PDU/ATSs.
- Monitor the operating status from the VMware vCenter and ESXi.
- Define detailed action setting for each event of the ESXi's power source.
- Manage the VMware vCenter and ESXi services.

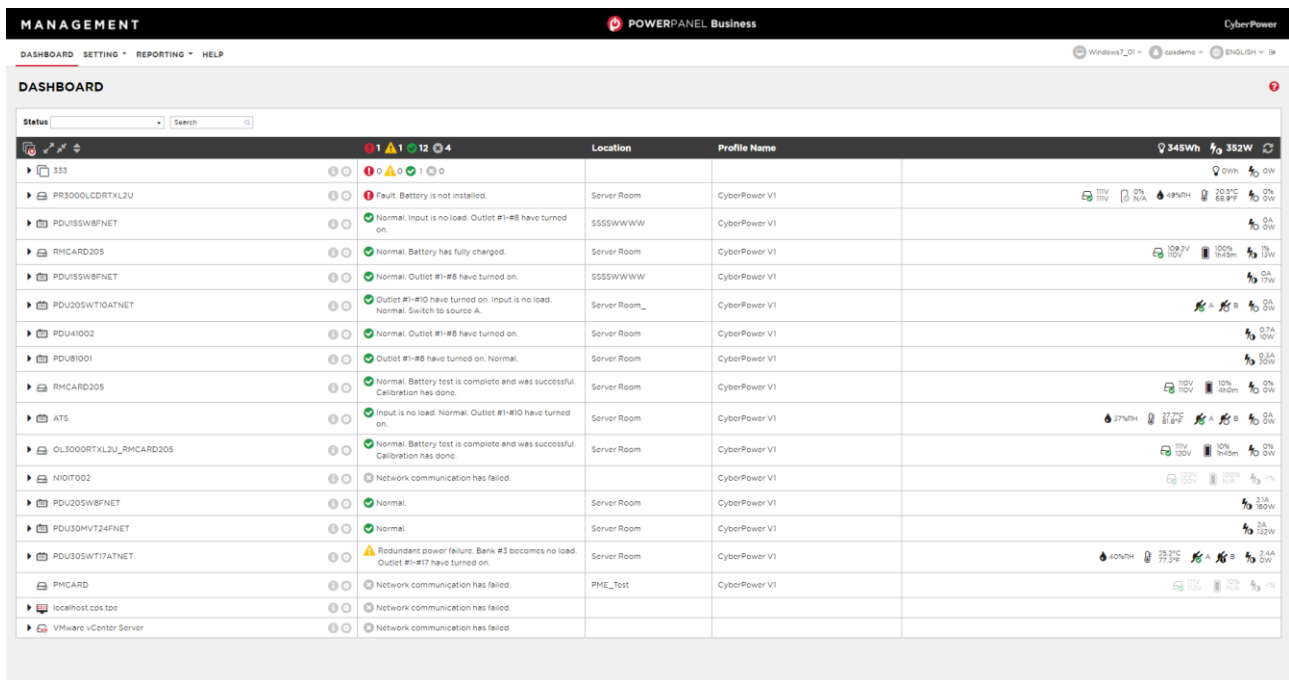

DASHBOARD page





3.1.1 Toolbar

The Toolbar provides information about the status of monitored devices and options to expand, add group or device.



Toolbar of DASHBOARD





These four buttons will allow users to add devices, expand or collapse all groups and device outlets, and sort the devices by name.

	Add Device. Click this button then the <i>Add Device</i> dialogue box will appear. (The function is only applicable to the administrator and super administrator.)
	Expand All. This button will expand all groups and device outlets.
	Collapse All. This button will collapse all groups and device outlets.
	Sort Device by Name. This button will sort devices by ascending or descending order.



The refresh button on the right side of the tool bar allows user to refresh DASHBOARD page.

	Refresh. Click this button to refresh DASHBOARD page.
---	--



The other four icons indicate the amount of monitored devices that have had severe-level or warning-level events occur, the numbers of devices that have lost communication with Management and the number of devices that are normal.

	Indicates severe-level power events such as <i>Runtime is insufficient</i> .
	Indicates warning-level power events such as <i>Utility power failure</i> .
	Indicates the devices which have lost communication with Management. Management cannot monitor or control computers and equipment when communication is lost.
	Indicates that there are no problems with these devices.

System will change the state according to the current power consumption of the entire system in past hour.



	Indicates the total power consumption of the entire system falls in a normal range.
	Indicates the total power consumption of the entire system exceeds the high threshold.
	Indicates the total power consumption of the entire system violates the low threshold.

System will change the state according to the current load of the entire system in past hour.

	Indicates the total load of the entire system is zero.
	Indicates the total load of the entire system falls in a normal range.
	Indicates the total load of the entire system is overload.

3.1.2 Node Components





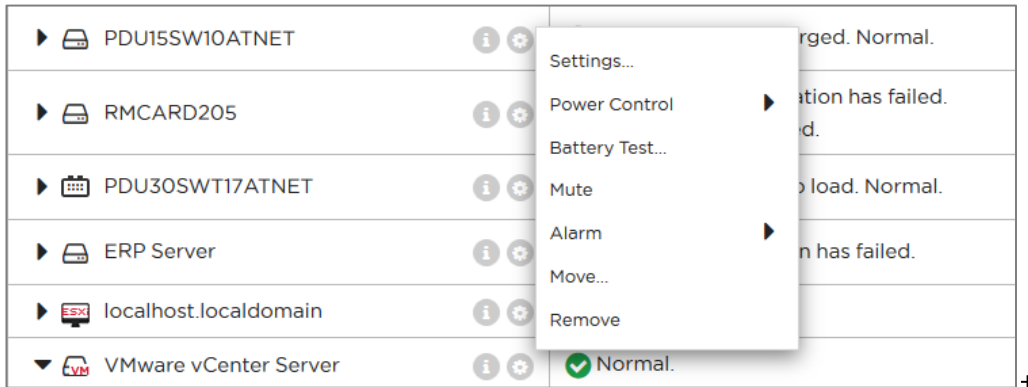







Each node has a name and an icon indicating what type it is. A UPS/PDU/ATS node provides detailed information about what power events have occurred and what the current status is.

The detail information for each node is available by clicking information icon , and a context menu for each node is available by clicking setting icon . (The function is only applicable to the administrator and super administrator.) This allows users to view detailed information such as *Summary* or *Status*, or request operations such as *Shutdown* or *Restart*. A menu item becomes disabled when this operation is in progress or is not supported.



A context menu appears by accessing a device node.



Each node can be one of the following types:

	A Group.
	A UPS. This UPS may have an RMCARD or is connected to a computer which is controlled by Local.
	A UPS. A VMware vCenter server or VMware ESXi host is connected with this UPS.
	A PDU. This PDU may be set to connect to a monitored UPS.
	An ATS. This ATS may be set to connect with the UPS which could be monitored by Management.
	Indicates the computer connected with the UPS is a VMware ESXi host.
	Indicates that is a VMware vCenter server.
	Indicates that is a storage in a vCenter.
	Indicates that is a Cluster. The Cluster is included in a vCenter.
	Indicates that is a VMware ESXi host. The ESXi host may be included by a vCenter server.
	Indicates that is a vApp. A vApp is a group of virtual machines.
	Indicates that is a virtual machine running on the VMware ESXi server.



Each node also has a column that indicates what the current state is and what power events have occurred. The column in a UPS node displays power events such as *Utility power failure* or *Runtime is insufficient* event while the column in a PDU node displays power events such as *Input is low load* or *Input is overload*.

The UPS/PDU/ATS nodes display a brief operating status consisting of schedules, utility power, batteries, support load and outlets. The brief status column displays in gray when local or network communication has failed.



A UPS can have the following states:

	Normal. The UPS is working normally.
	Power Failure. There is no utility power supplied to UPS.
	Bypass. The UPS has switched to bypass mode and is supplying direct utility power.
	Boost. The utility voltage is below the regular voltage and UPS is increasing the utility voltage.
	Buck. The utility voltage is beyond the regular voltage and UPS is decreasing the utility voltage.
	Test. A battery test is processing.



Batteries can have the following states when UPS is operating:

	Not Present. Batteries are absent and there is no battery power.
	Normal. Batteries are not being using.
	Charging. Batteries stops discharging due to a power event and are being charged.
	Discharging. The UPS is supplying battery power to its load.
	Fully Charged. Batteries are at 100% capacity.

UPS/PDU/ATSs have the following states according to their current load:

	No Load. There is no output load.
	Low Load. The PDU is in a low load condition.
	Normal. The output power is normal.
	Near Overload. The PDU is near the overload condition.
	Overload. Output consumption of equipment exceeds the rating load on UPS or the PDU is in an overload condition.

ATS have the following states on functioning:

	ATS uses this input source as current source, and this source is normal.
	ATS uses this input source as redundant source, but this source is normal.
	This power source of ATS is power failure.

The sensor on the UPS/PDU/ATS has the following states according to the environment temperature:

	Normal. Indicates the temperature measured by the sensor is in a predefined normal range.
---	--

	Overheated. Indicates the current temperature exceeds the high temperature threshold.
	Undercooled. Indicates the current temperature violates the low temperature threshold.

The sensor on the UPS/PDU/ATS has the following states according to the relative humidity:

	Normal. Indicates the humidity as a percentage measured by the sensor is in a predefined normal range.
	Over wet. Indicates the current humidity exceeds the high humidity threshold.
	Dry. Indicates the current humidity violates the low humidity threshold.

A group has the following states according to the total power consumption:

	Indicates the total power consumption of the group falls in the normal range.
	Indicates the total power consumption of the group exceeds the high threshold.
	Indicates the total power consumption of the group violates the low threshold.

3.1.3 Power Device Management

(The contents in this section are only applicable to the administrator and super administrator.)

3.1.3.1 Add Device

In order to monitor and control power device UPS/PDU/ATS, these devices must be added to PowerPanel Business Management by clicking **Add Device** button on the toolbar.



Add Device button on the toolbar

The Add Device dialog will show up.

Add Device ✕

Group Name: ✕ +

Add Device IP: +

Select Device ↻

<input type="checkbox"/>	Vendor MIB	Device Name	Type	Location	IP Address	MAC Address	Uptime
<input checked="" type="checkbox"/>	CyberPower	PR3000LCDRTXL2U	UPS	Server Room	192.168.208.211	00-0C-15-00-FC...	55 days 12 hours 16 m.
<input checked="" type="checkbox"/>	CyberPower	PDU15SW8FNET	PDU	SSSSWWWW	192.168.208.222	00-0C-15-40-2C...	163 days 4 hours 5 mi.
<input checked="" type="checkbox"/>	CyberPower	RMCARD205	UPS	Server Room	192.168.208.236	00-0C-15-01-CB...	39 days 19 hours 27 ...
<input type="checkbox"/>	CyberPower	PDU15SW8FNET	PDU	SSSSWWWW	192.168.208.221	00-0C-15-40-2C...	55 days 12 hours 19 m.
<input type="checkbox"/>	CyberPower	PDU20SWT10ATNET	ATS	Server Room_	192.168.208.223	00-0C-15-00-00...	55 days 12 hours 18 m.

VMware vCenter and ESXi +

	Name	IP Address	Type
	localhost.cps.tpe	192.168.208.33	VMware ESXi
	VMware vCenter Ser...	192.168.208.253	VMware vCenter Server

CANCEL **SAVE**

Add Device dialog

All the devices already in Management will be shown on the list, choose the devices you want to add from the list then click **SAVE** button to complete. Click the refresh button  to refresh the device list. If the device you want to add is not on the list, go to **SETTING/Network Configurations/Auto-Discover Range** page to edit the scan range. Please refer to **SETTING/Auto-Discover Range** for more details.

3.1.3.2 Move Device

Click the setting icon of the device you want to move and select **Move** in the context menu. A **Move** window will display and select the target group from the list. After selecting the target group, click **SAVE** to move the group.

3.1.3.3 Remove Device

Click the setting icon of the device you want to remove and click **Remove** in the context menu. Click **SAVE** to remove the device. When a device is removed, its powered computers and equipment will also be removed.

3.1.3.4 Change Settings

Click the setting icon of the device you want to change setting and click **Settings** in the context menu, a **Setting** window will appear. User can change the Name of this device or configure the proper thresholds to aware of violating consumption thresholds. Once the power consumption violates thresholds, Management will warn administrators of the violation. When the thresholds are set blank, Management will use the thresholds of the **Default Energy** in **REPORTING/Energy Use/Settings** page instead of the thresholds in **Settings** of each power device.

3.1.4 Power Device Details

UPS/PDU/ATS provides further information; this information will show up by clicking info icon of each device. This includes summary, status, information, UPS, and Energy.

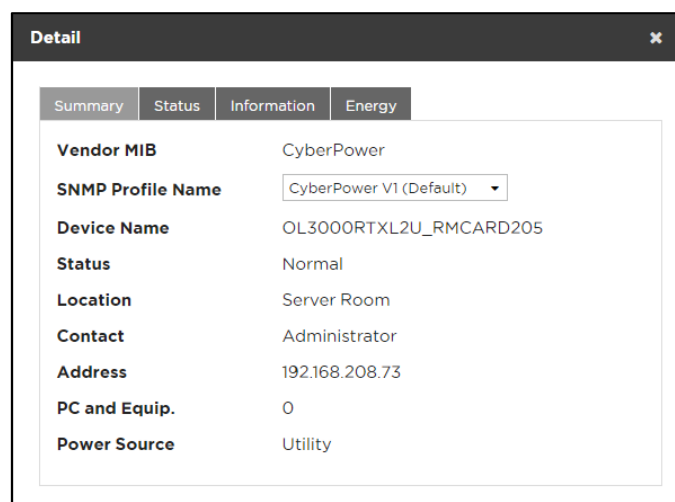

Details of a UPS monitored by Local

3.1.4.1 Summary

The **Summary** tab provides an overview of the system information:

- **Vendor MIB:** The vendor MIB the device uses.
- **SNMP Profile Name:** The name of the SNMP profile the device uses.
- **Device Name:** The name of the selected device.
- **Status:** Displays the present status of the selected UPS/PDU/ATS.
- **Location:** Where the UPS/PDU/ATS is located.
- **Contact:** Who to contact about the UPS/PDU/ATS.
- **Address:** The IP address of the UPS RMCARD, PDU or Local computer's network interface.
- **PC and Equip.:** The number of the powered computers and equipment.
- **Power Source:** The power source of the UPS, e.g. *Utility* or *Battery*.
- **Outlets:** The number of outlets on the UPS/PDU/ATS.
- **Outlet On:** The outlets which are supplying power.
- **Outlet Off:** The outlets which are not supplying power.
- **Current Source:** Indicates which input source is being using and will be also annotated preferred or redundant source.

3.1.4.2 Status

The **Status** tab displays details about the UPS/PDU/ATS.

- **Current:** The output current in Amps.
- **Load:** The power draw of PDU/ATS supplying power to connected equipment.
- **Source A Voltage:** The voltage of the input power supplied to the source A of ATS.
- **Source B Voltage:** The voltage of the input power supplied to the source B of ATS.
- **Envir. Temperature:** Indicates the measured temperature from the environment sensor.
- **Envir. Humidity:** Indicates the measured humidity from the environment sensor.
- **Contact:** Indicates generic equipment connects to this sensor. Users can define the name and state in RMCARD web for each contact and monitor the state is normal.
- **Outlets:** The status of each outlet on the UPS/PDU/ATS and the name of the connected computer or equipment.
- **Input:** Displays the status of the utility power supplied to the UPS.
- **Voltage:** The voltage of the utility power supplied to the UPS.
- **Frequency:** The frequency of the utility power supplied to the UPS in Hertz.
- **Output:** Displays the status of the output power that is being supplied to connected equipment.
- **Load Consumption:** The power draw of the connected equipment expressed as a percentage of the total load capacity. This displays as watts on some UPS models.
- **Battery:** Displays the status of the battery packs.
- **Capacity:** The capacity of the batteries, expressed as a percentage of full charge.

- **Remaining Runtime:** The estimated amount of time that the UPS can supply power to its load.
- **System:** Displays the operating status of the UPS.
- **Environment Sensor:** Indicates whether the environment sensor has been installed on the UPS/PDU/ATS. Note: When the sensor cannot be detected anymore, it will be annotated *No Response*. Users can click the **Uninstall** to reflect it if it had been removed physically from the UPS/PDU/ATS.
- **Bank # Load:** The power of the PDU/ATS bank supplied power to the connected equipment.
- **Bank # Current:** The current of the PDU/ATS bank supplied power to the connected equipment.
- **Phase:** The phase information, including Name, Input Voltage and Current, of a 3-phase PDU.

3.1.4.3 Information

Information tab shows information about the UPS/PDU/ATS.

- **Type:** The type of the device, such as On-Line, Line Interactive or Sinewave Line Interactive for UPS; or Monitored or Switched for PDU/ATS.
- **Model Name:** The model of the UPS/PDU/ATS.
- **Firmware Version:** The firmware version of the UPS/PDU/ATS.
- **MAC address:** The MAC address of the UPS RMCARD, PDU or Local computer's network interface.
- **Serial Number:** The serial number of the UPS.
Note: This will give the internal serial number on some models.
- **Power Rating:** The Volt-Amp rating (VA) and power rating (Watts) of the UPS.
- **Voltage Rating:** The output voltage rating (Volts) of the UPS.
- **Frequency Rating:** The output frequency rating (Hz) of the UPS.
- **Battery Replacement Date:** The date that the batteries were last replaced. This should be set at the time of battery replacement. If this date has not been set, it is recommended that this date should be set immediately.
- **External Battery Pack:** The amount of external battery packs connected to the UPS.
- **Outlets:** The number of outlets on the PDU/ATS.

3.1.4.4 UPS

The **UPS** tab shows the connected power sources of PDU/ATS, the IP address and Outlet of UPS.

3.1.4.5 Energy

The **Energy** tab shows the chart how to spend the energy in a specified period and also shows the energy statistics of the current target node and entire system.

Each UPS, PDU, ATS and outlet of Metered by Outlet PDU whose consumption will be logged per hour and each group which contains these UPS/PDU/ATS will work accumulating the consumption of data. These data which logged the consumption in the past can be gathered to render a chart in a past day, a past month, a past year and a past decade accordingly. Administrators will realize how much energy has been spent in a past period. Energy can be spent more efficiently and reduce the waste.

For PDU and outlets of Metered by Outlet PDU, the Peak Load value will also be recorded. Management will show the Peak Load value, the time when this value happens and the time when the Peak Value is reset.

3.1.5 Power Device Operations

(The contents in this section are only applicable to the administrator and super administrator.)

Management provides control functions for a UPS/PDU/ATS. Click the setting icon of each device or the outlet of this device, the context menu will show up.

3.1.5.1 Power Control

- **Power Off:** Click **Power Off** and a confirmation window will appear. Decide whether to perform an immediate or a sequenced power off then click **OK** to begin. When a UPS or a PDU initiates a sequenced power off, computers connected to the UPS/PDU/ATS that have Local or Remote installed will initiate shutdown prior to the sequenced power off.

Note: A force power off will likely result in connected computers losing power.

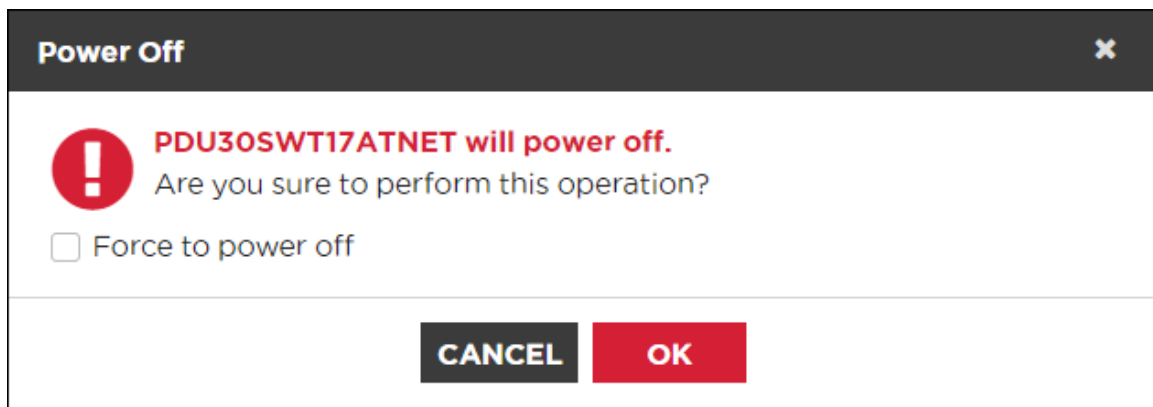

A confirmation window of a UPS power off operation

- **Power On:** Click **Power On** to have the UPS/PDU/ATS turn on output power. Decide whether to turn on output power immediately or after a delay in the confirmation window. Click **OK** to begin.

Note: Some computers require manual booting when a UPS or a PDU powers on. To change this, set the computers BIOS to boot when power is restored.

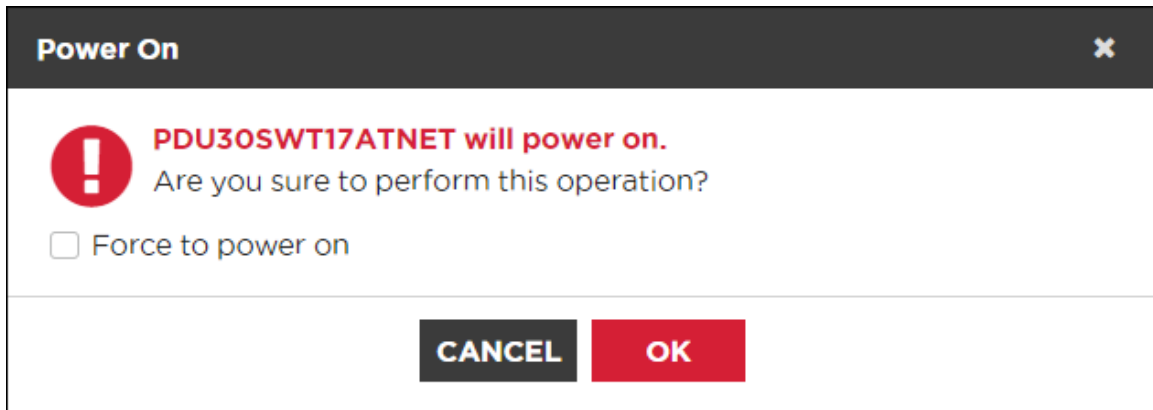

A confirmation window of a UPS power on operation

- **Power Cycle:** Initiates a **Power Cycle** on the UPS/PDU/ATS. This will turn the UPS/PDU/ATS off then back on or vice versa. Decide whether to initiate an immediate or a sequenced power cycle and click **OK** to begin. A sequenced power cycle will cause computers connected to the UPS/PDU/ATS that have Local or Remote installed to shut down prior to the power cycle.

Note: A force power cycle off will likely result in connected computers losing power.

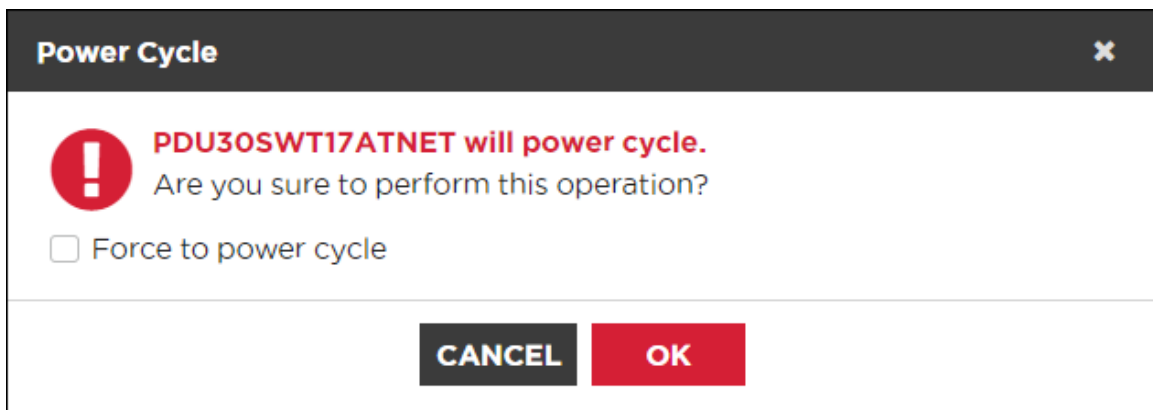

A confirmation window of a UPS power cycle operation

Note: If a PDU is connected to a UPS, a power off or a power cycle to the UPS may also cause all computers on this PDU to shut down.

3.1.5.2 Outlet Control

Click Outlet Control and then a Device Outlet Control window will appear, a table of current outlet status will be shown on the windows. Choose the Action and Outlets you want to control and then click CONTROL OUTLET(S) button.

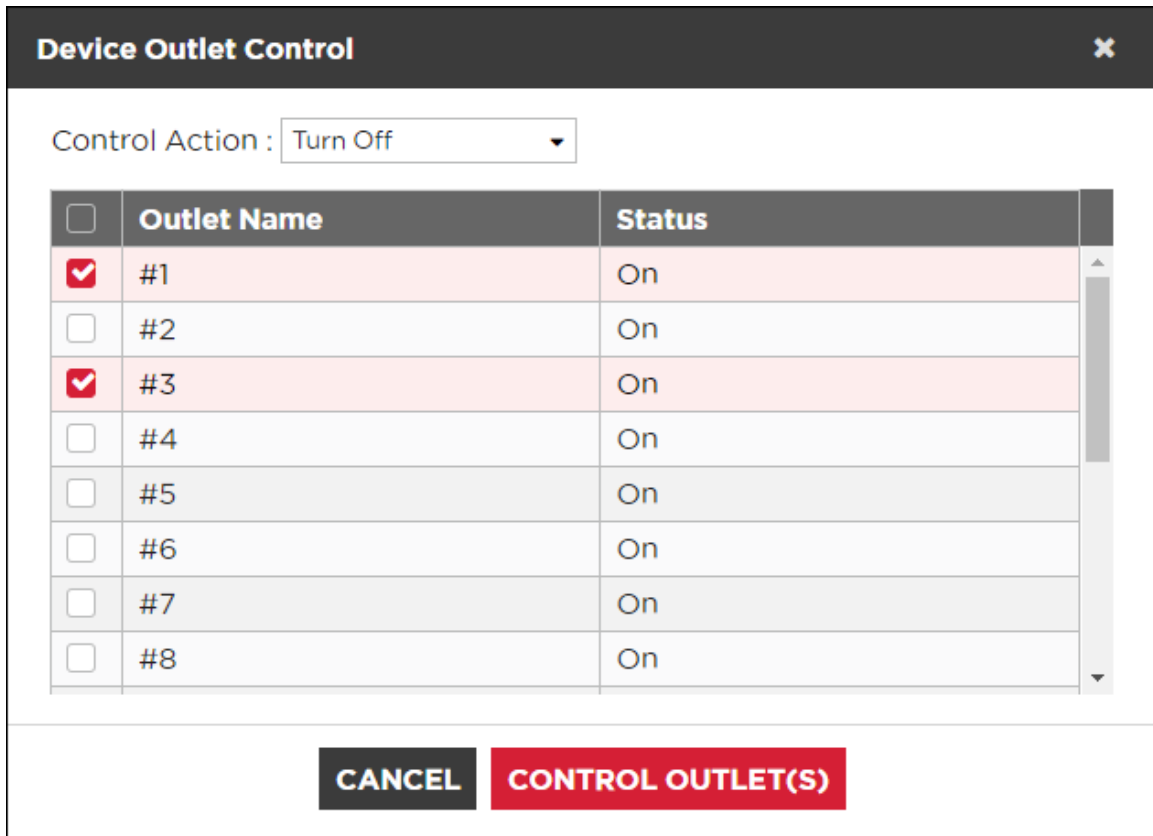

Outlet Control Window

Note: Not all PDUs support this function.

3.1.5.3 Battery Test

Click **Battery Test** from the context menu and the UPS will initiate a battery test.

3.1.5.4 Mute

Click **Mute** from the context menu to mute the alarm.

3.1.5.5 Alarm

Click **Alarm** from the context menu to enable or disable the UPS alarm.

3.1.5.6 Preferred Source

Click **Preferred Source** from the context menu to select which input source to be the primary one.

3.1.6 VMware vCenter and ESXi Management

(The contents in this section are only applicable to the administrator and super administrator.)

3.1.6.1 Add VMware vCenter and ESXi

In order to monitor and control the VMware nodes, users can click the **Add Device** button on the toolbar. An **Add Device** dialog will appear for users to add VMware vCenter and ESXi.



Add Device button on the toolbar

The Add Device dialog will show up. Users can add VMware vCenter and ESXi in the section of **VMware vCenter and ESXi**. A dialog will show up by clicking the **Add** button **+**. Note: VMWare feature is not support ESXi free edition.

Add Device

Group Name x v +

Add Device IP v +

Select Device ↻

<input type="checkbox"/>	Vendor MIB ↑↓	Device Name ↑↓	Type ↑↓	Location ↑↓	IP Ad
<input checked="" type="checkbox"/>	CyberPower	RMCARD205	UPS	Server Room	192.168.208.238
<input checked="" type="checkbox"/>	CyberPower	PDU81001	PDU	Server Room	192.168.208.238
<input checked="" type="checkbox"/>	CyberPower	RMCARD400	UPS	Server Room	192.168.208.238
<input checked="" type="checkbox"/>	CyberPower	OL3000RTXL2U	UPS	test	192.168.208.238
<input checked="" type="checkbox"/>	CyberPower	ATS	ATS	Server Room	192.168.208.238

VMware vCenter and ESXi +

	Name	IP Address	Type
<input type="checkbox"/>	localhost.localdomain	192.168.208.238	VMware ESXi
<input type="checkbox"/>	VMware vCenter Server	192.168.20.249	VMware vCenter Server

CANCEL **SAVE**

Add Device dialog

VMware vCenter and ESXi x

Notice:VMWare feature does not support the free edition of ESXi

Product

IP Address/Name

User Name

Password

CANCEL **SAVE**

Add VMware vCenter and ESXi dialog

The detailed data is described below:

- **Product:** Specify whether to add a vCenter server or an ESXi host.
- **IP Address/Name:** Configure the IP address or hostname for the vCenter server or the ESXi host.
- **Port:** Set the port number for Management to access the vCenter host.

- **Username:** Set the username to access the vCenter server or ESXi host.
- **Password:** Set the password for the username.
- **Attach plugin to vCenter Server:** Decide whether to attach a vCenter server plug-in. If this option is enabled, Management will install a plugin which expands the capability of vCenter server to present the Management web interface during establishing connection. After the plugin is installed, the vSphere Client interface will attach a new tab which displays Management web page.

Specify the product type and enter the necessary data. Press the **SAVE** button to add the VMware vCenter and ESXi.

3.1.6.2 Update VMware vCenter and ESXi

Click the setting icon of the vCenter server or ESXi host you wish to remove and select **Update** in the context menu, then the **Update** window will appear and allow you to configure the connection settings.

- **Port:** Set the port number for Management to access the vCenter server.
- **Username:** Set the username to access the vCenter server or ESXi host.
- **Password:** Sets the password for the username.
- **Attach plugin to vCenter Server:** Decides whether to attach a vCenter server plug-in.

Note: Changing the port, user name or password may cause communication loss with Management.

3.1.6.3 Remove VMware vCenter and ESXi

Click the setting icon of the vCenter server or ESXi host you wish to remove and select **Remove** in the context menu. The **Remove Infrastructure** window will display. Click **REMOVE** to apply the removal.

If the plugin has been installed in vCenter server, the plugin will also be uninstalled during removal. If the ESXi has been connected with the power device, the power source will also detach the ESXi.

3.1.7 VMware vCenter and ESXi Details

The detail information of VMware vCenter and ESXi will show up by clicking info icon of each node.

3.1.7.1 Summary

The **Summary** tab provides an overview of the VMware node information:

- **Virtual Machine:** Indicates the selected VMware node is virtual machine.

- **Name:** The name of the selected virtual machine.
 - **Status:** Displays the present status of the selected virtual machine.
 - **Address:** The IP address of the virtual machine when the virtual machine is running.
- **VMware vApp:** Indicates the selected VMware node is a VMware vApp.
 - **Name:** The name of the selected vApp.
 - **Status:** Displays the present status of the vApp.
 - **VM Amount:** The number of virtual machines on the target vApp.
- **VMware ESXi Host:** Indicates the selected VMware node is an ESXi host. It may be the ESXi host to which the selected virtual machine belongs.
 - **Name:** The name of the selected ESXi host.
 - **Address:** The IP address of the ESXi host.
 - **Status:** Displays the present status of the ESXi host.
 - **Type:** Specifies the node is ESX or ESXi host.
 - **VM Amount:** The number of virtual machines on the target ESXi host.
- **VMware Cluster:** Indicates the selected VMware node is a Cluster.
 - **Name:** The name of the selected Cluster.
 - **Status:** Displays the present status of the Cluster.
 - **DRS Status:** Displays the present DRS (Distributed Resource Scheduler) status on the target Cluster.
 - **HA Status:** Displays the present HA (High Availability) status on the target Cluster.
 - **ESXi Host Amount:** The amount of ESXi hosts on the target Cluster.
 - **vApp Amount:** The amount of vApps on the target Cluster.
 - **VM Amount:** The number of virtual machines on the target Cluster.
- **VMware vCenter Server:** Indicates the selected VMware node is a vCenter server. It may be the vCenter server to which the selected ESXi host or selected virtual machine belongs.
 - **Name:** The name of the selected vCenter server.
 - **Address:** The IP address of the vCenter server.
 - **Status:** Displays the present status of the vCenter server.
 - **ESXi Host Amount:** The amount of the ESXi hosts of the target vCenter server.
- **Storage:** Indicates the selected VMware node is a Storage.
 - **Name:** The name of the selected Storage.
 - **Type:** Specifies it is local or shared Storage.
 - **Status:** Displays the present status of the Storage.
- **UPS:** Displays detailed information of the UPS which is supplying power to the selected VMware node.

- **Name:** The name of the UPS.
- **Address:** The IP address of the UPS.
- **Outlet:** Indicates the outlet number and what the bank type of connected outlet.
- **Status:** Displays the present status of the UPS.

Note: Not each VMware node provides the same information. The information will vary depending on VMware node.

3.1.8 Group Management

(The contents in this section are only applicable to the administrator and super administrator.)

UPS/PDU/ATs and ESXi nodes can be grouped for easy management. Orders can then be issued to multiple devices in a group.

3.1.8.1 Add Group

Click **Add Group** button “+” on the Add Device dialog to create a new group after clicking **Add Device** button on the toolbar.

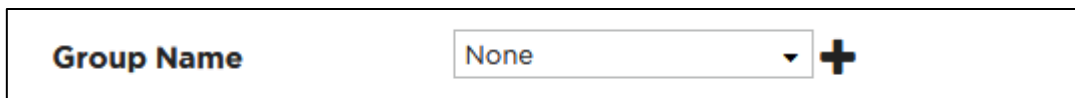

Add Group button on the toolbar

You can also choose parents-group in the New Group dialog. Enter the new group name and choose the group under which the new group is, and then click **SAVE** button to add a new group.

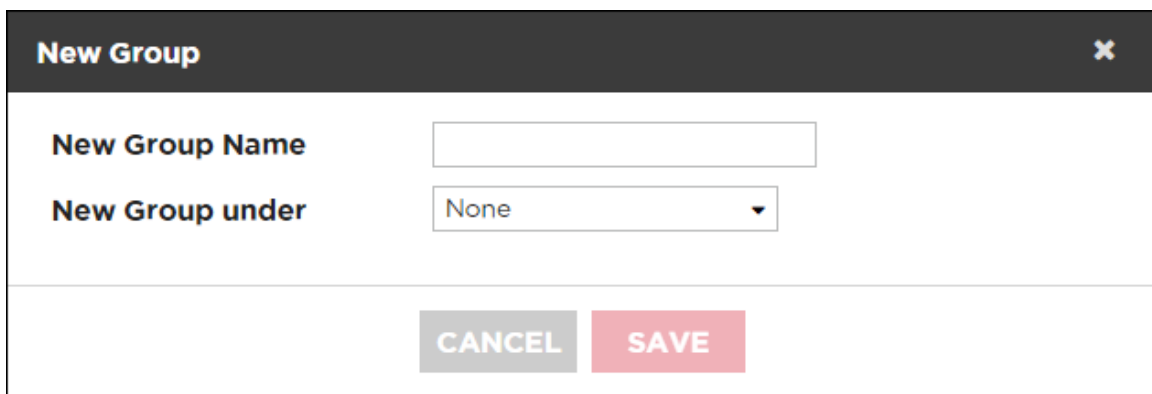

New Group dialog

3.1.8.2 Edit Group

Select **Edit** from the context menu, an **Edit Group** window will appear. User can edit group name, edit devices and ESXi nodes in the group, and set Energy Consumption Threshold of this group in the edit windows.

Edit Group [Close]

Group Name: 333 +

Energy Consumption Alert Threshold

High Threshold: High KWh

Low Threshold: Low KWh

[CANCEL] [SAVE]

Edit Group dialog

3.1.8.3 Move Group

Click the Setting icon of the group you wish to move and select **Move** in the context menu. Select the target group from the list in the **Device Move** dialog. After selecting the target group, click **SAVE** to move the group.

3.1.8.4 Remove Group

Click the Setting icon of the group you wish to remove and select **Remove** from the context menu. The **Group Remove** window will open; click **REMOVE** to remove this group. Removing a group will not remove the sub-groups or the UPS/PDU/ATSs belonging to this group. These items will be moved to the main group.

3.1.9 Group Details

Click the information icon of the group, a detail windows will show up. User can find Summary and Energy details in that window.

Summary	Energy
Group Name	Group 1
Statistics	
Normal	2
Sereve	0
warning	0
Communication lost	0
Types	
UPS	1
PDU	0

Summary tab of Details

3.1.9.1 Summary

Each group provides the statistics of all UPS/PDU/ATS from the **Summary** tab of **Details** and includes the following summary information:

- **Group Name:** A name of the selected group.
- **Statistics:** Indicates statistics about the operating conditions of the UPS/PDU/ATS:
 - **Normal:** Indicates a UPS/PDU/ATS which is normal.
 - **Severe:** Indicates a UPS/PDU/ATS with severe-level power events such as *Runtime is insufficient*.
 - **Warning:** Indicates a UPS/PDU/ATS with warning-level power events such as *Utility power failure*.
 - **Communication Lost:** Indicates a UPS/PDU/ATS which has lost communication with Management.
- **Types:** Indicates the statistics of UPS/PDU/ATS.

3.1.9.2 Energy

The **Energy** tab shows the chart how to spend the energy in a specified period and also shows the energy statistics of the current target group.

3.1.10 Group Operations

(The contents in this section are only applicable to the administrator and super administrator.)

Some or all devices in a group can have the following commands issued to them:

3.1.10.1 Power Control

- **Power Off:** Click **Power Off** and a confirmation window will appear. Pick the UPS/PDU/ATS from the list and decide whether to perform an immediate or a sequenced power off. Click **OK** to begin. When the UPS/PDU/ATS initiates a sequenced power off, computers with Local or Remote installed will initiate a shutdown prior to the sequenced power off. An immediate power off will likely cause those lose power.

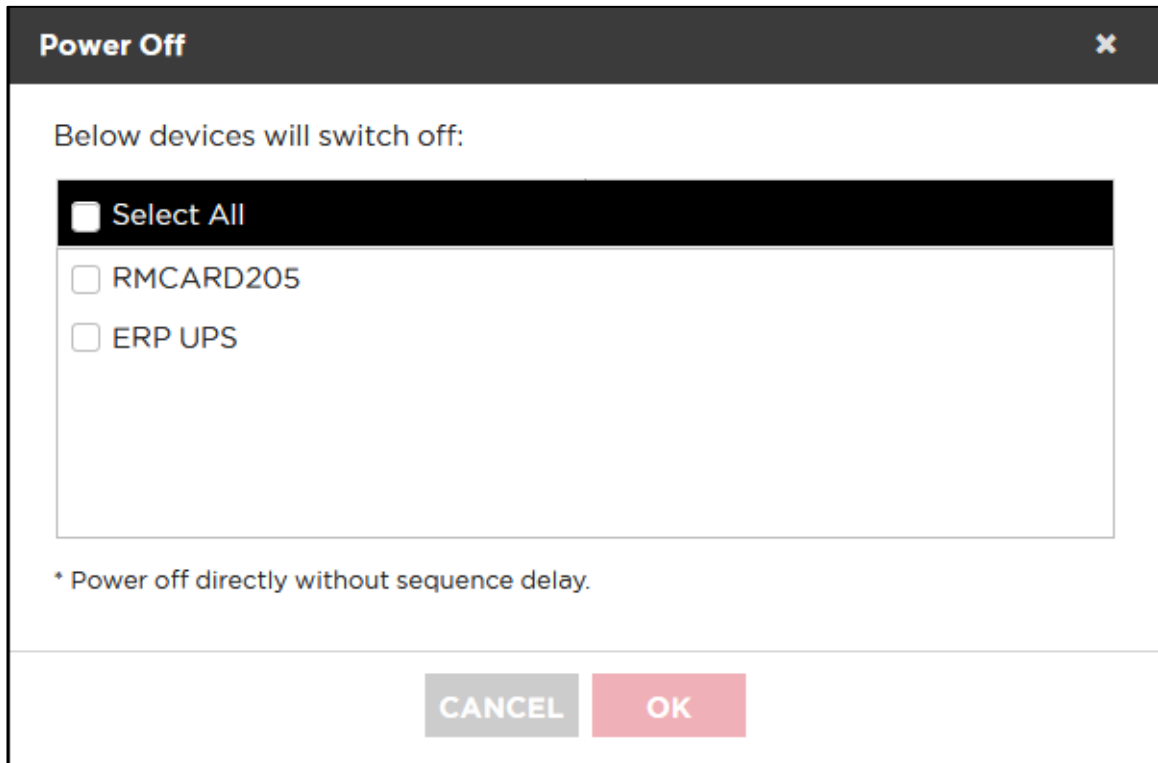

A confirmation window of a bulk power off operation

- **Power On:** Click **Power On** and a popup window appear. Pick the UPS/PDU/ATS from the list and determine whether to perform an immediate or a sequenced power on. Click **OK** to begin.
Note: Some computers require manual booting when a UPS or a PDU powers on. To change this, set the computers BIOS to boot when power is restored.

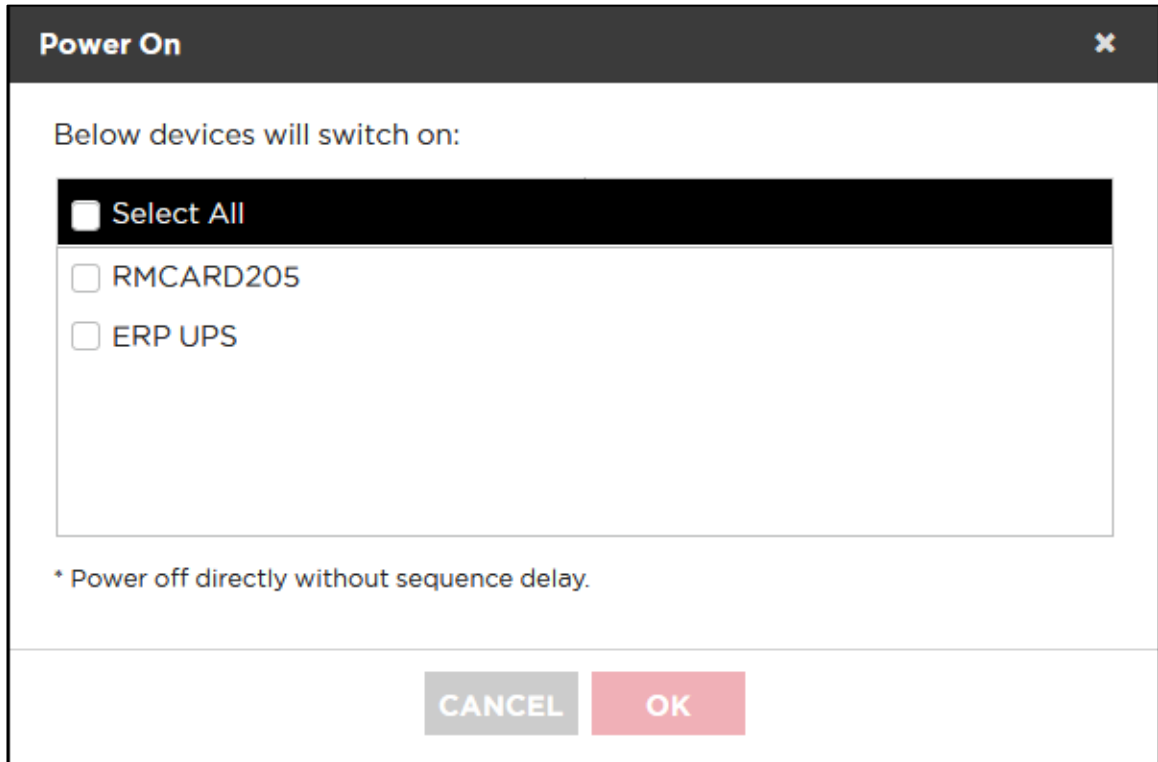

A confirmation window of a bulk power on operation

- **Power Cycle:** Click **Power Cycle** and a popup window appear. Pick the UPS/PDU/ATS from the list and determine whether to perform an immediate or a sequenced power cycle. Click **OK** to begin.

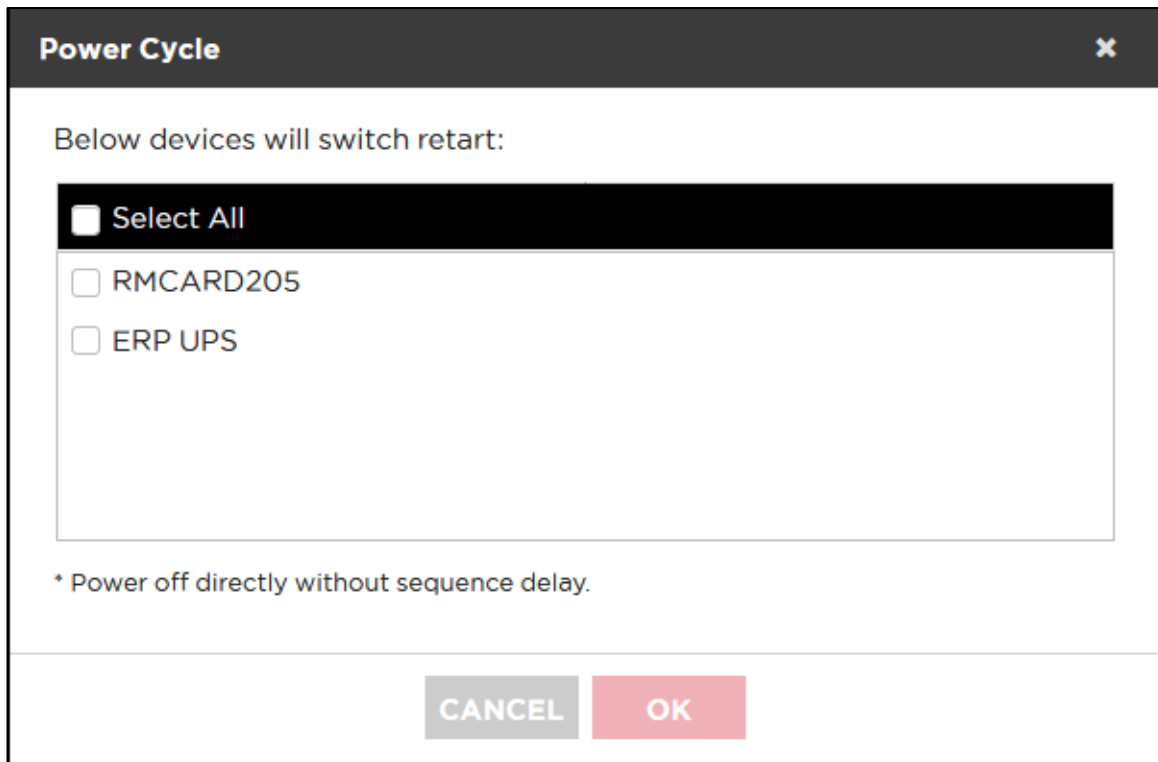

A confirmation window of a bulk power cycle operation

Note: If a group contains the UPS systems which has connected with PDU units, a power cycle or a power off to the selected group will result in computers shutdown on the PDU units.

3.1.10.2 Battery Test

Only UPS units can perform a battery test. Click **Battery Test** from the context menu of the selected group. All UPS units in that group will be listed in the confirmation window. Click **OK** to initiate the battery test on all selected UPS units.

3.1.10.3 Mute

Click **Mute** from the context menu to mute the alarm.

3.1.10.4 Alarm

Click **Alarm** from the context menu to enable or disable the UPS alarm.

3.2 SETTING

(The contents in this section are only applicable to the administrator and super administrator.)

3.2.1 License Management

Fill in the **License Key** and click the **SUBMIT** button to activate PowerPanel Business Management license.

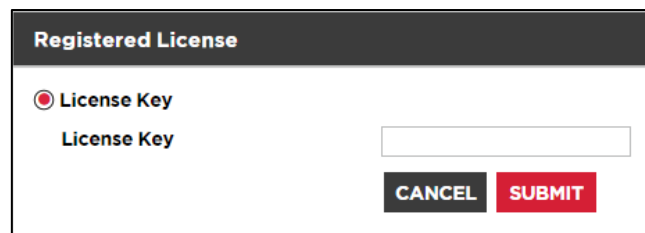
A dialog box titled "Registered License" with a dark header. Below the header, there is a red radio button next to the text "License Key". Underneath, the text "License Key" is followed by a white text input field. At the bottom right of the dialog, there are two buttons: a black "CANCEL" button and a red "SUBMIT" button.

Registered license dialog

3.2.2 Connection Check

3.2.2.1 Connection Check with RMCARD / PPB LOCAL

The connection check allows users to check the connection between PPB Management and RMCARD / PPB LOCAL.

Before doing this check, we suggest you do the following environment check first:

1. Check your computer and network environment: make sure the TCP/UDP port 3052 and 53566 are open.
2. Check your firewall and Anti-virus setting: make sure it doesn't block TCP/UDP port 3052 and 53566.
3. Check your network devices such as router/gateway and so on: make sure the policy allows TCP/UDP port 3052 and 53566.

4. Check your PPB and connecting target: make sure the PowerPanel Secret Phrase are the same.

Connection Check with RMCARD / PPB LOCAL

NOTICE: Few check points we would suggest you do before doing the check.

1. Check your computer and network environment: make sure the TCP/UDP port 3052 and 53566 are open.
2. Check your firewall and Anti-virus setting: make sure it doesn't block TCP/UDP port 3052 and 53566.
3. Check your network devices such as router/gateway and so on: make sure the policy allows TCP/UDP port 3052 and 53566.
4. Check your PPB and connecting target: make sure the PowerPanel Secret Phrase are the same.

Connecting Target: PPB LOCAL

IP Address: 192.168.208.237

CANCEL CHECK

Check Result

100% Complete

PPB REMOTE Firewall Check : Pass
PPB REMOTE Anti-virus Check : Unknown
Network Port Check(TCP 3052) : Fault
Network Port Check(UDP 3052) : Unknown
PowerPanel Secret Phrase Check : Unknown
Receiving Data from the target : Fault
Check Date : 2023-03-16 09:54:56 AM

Connection Check with RMCARD / PPB LOCAL in PPB Management

- **Connecting Target:** There are two options:
 1. PPB Local
 2. RMCARD
- **IP Address:** This is the connection target IP. Click “CHECK” to start connection check, and click “CANCEL” if you want to stop the progress.
- **Check Result:** Shows the result after the connection check. There are three types of status:
 1. **Pass:** PPB can successfully connect with the target in this environment.
 2. **Fault:** PPB cannot connect with the target in this environment.
 3. **Unknown:** PPB may not connect with the target in certain situations. Therefore, please check the environment settings.

The connection check result includes six checks:

1. **PPB Management Firewall Check:** Check the firewall status of the computer installing the PPB Management.
2. **PPB Management Anti-virus Check:** Check the Anti-virus software status of the computer installing the PPB Management.
3. **Network Port Check (TCP 3052):** Check whether PPB Management can connect with the target through TCP Port 3052.
4. **Network Port Check (UDP 3052):** Check whether PPB Management can connect with the target through UDP Port 3052.
5. **PowerPanel Secret Phrase Check:** Check the Secret Phrase which is set in the target is the same as the RMCARD / PPB LOCAL.
6. **Receiving Data from the target:** Check whether PPB Management can receive the data from the target which represents the system can connect with the target successfully.

3.2.2.2 Check Result Records

Check Result Records			
Date & Time	Connecting Target	IP Address	Check Result
2023-03-16 10:08:33 AM	PPB LOCAL	192.168.208.1	PPB REMOTE Firewall Check : Pass PPB REMOTE Anti-virus Check : Unknown Network Port Check(TCP 3052) : Fault Network Port Check(UDP 3052) : Unknown PowerPanel Secret Phrase Check : Unknown Receiving Data from the target : Fault
2023-03-16 09:54:56 AM	PPB LOCAL	192.168.208.237	PPB REMOTE Firewall Check : Pass PPB REMOTE Anti-virus Check : Unknown Network Port Check(TCP 3052) : Fault Network Port Check(UDP 3052) : Unknown PowerPanel Secret Phrase Check : Unknown Receiving Data from the target : Fault

Check Result Records

PPB records each check result. The columns are described below:

- **Date & Time:** The completed time of this connection check.
- **Connecting Target:** PPB LOCAL or RMCARD.
- **IP Address:** This is connecting target IP.
- **Check Result:** The result records of the connection check.

3.2.2.3 PPB Transaction Detail Records

This section is the detailed information of the check results. If the connection check still failed after you adjust the network environment settings, please provide this information for us.

PPB Transaction Detail Records					
Date & Time	IP Address	Target	Send/Receive	Port	Information
2023-03-16 10:08:33 AM	192.168.208.1	PPB LOCAL	Receive	3052	Connection check failed
2023-03-16 10:08:33 AM	192.168.208.1	PPB LOCAL	Send	3052	Failed to register 192.168.208.67 with the target, please check TCP 3052 or Connecting Target
2023-03-16 10:08:23 AM	192.168.208.1	PPB LOCAL	Send	3052	Start connection check
2023-03-16 09:54:56 AM	192.168.208.237	PPB LOCAL	Receive	3052	Connection check failed
2023-03-16 09:54:56 AM	192.168.208.237	PPB LOCAL	Send	3052	Failed to register 192.168.208.67 with the target, please check TCP 3052 or Connecting Target
2023-03-16 09:54:55 AM	192.168.208.237	PPB LOCAL	Send	3052	Start connection check

PPB Transaction Detail Records

3.2.3 Network Configurations

3.2.3.1 Network Configurations

3.2.3.1.1 Host IP Configuration

According to chapter 2.3, users can access PowerPanel Business Management through the default URL and can assign an IP to PowerPanel Business Management web browser in Host IP Configuration.

- **Host IP:** when the computer installed with PowerPanel Business Management has multiple IPs, users can choose one of the IPs for the web browser.

3.2.3.1.2 HTTPS

PowerPanel Business Management allows users to change the secure level and port explained below:

- **HTTPS Secure:** Enable this option for web access to be over the HTTPS connections.
- **HTTPS Port:** Determines which port to be used over the HTTPS connections. The default port is 53568.

Once the secure level is changed, the new secure level will be taken effect. All pages can't be displayed during the duration to restart server.

When HTTPS secure is enabled, the browser warning will be presented after the new level is taken effect. This indicates that the user's browser considers the connection is risky. Users can ignore the warning page and continue the web access, or provide a SSL certificate which is produced by the commercial certificate providers or any trusted certificate authority.

If the user has his own SSL certificate, refer to **Import SSL Certificates** section for further details how to import the new certificate.

3.2.3.2 SNMP Configurations

PowerPanel Business Management can interact with and access device information via SNMPv1 and SNMPv3. Early UPS and PDU models which only accept SNMPv1 commands and newer models which support SNMPv3 can be controlled by Management.

Protocol Version: Users can choose which SNMP protocol to use over network communication between Management and devices. There is one CyberPower V1 and one CyberPower V3 vendor MIB available by default because PowerPanel Business Remote attempts on the correct SNMP protocol for device to interact.

The screenshot shows the 'SNMP CONFIGURATIONS' page in the PowerPanel Business Management interface. The page is divided into two sections: 'SNMPv1' and 'SNMPv3'.

SNMPv1 Configurations:

Vendor MIB	Profile Name	SNMP Community	SNMP Trap Community
✓ CyberPower	CyberPower V1	private	public
✓ APC	apc v1	private	public
✓ EATON	eaton v1	private	public

SNMPv3 Configurations:

Vendor MIB	Profile Name	User Name	Authentication Protocol	Authentication Key	Privacy Protocol	Privacy Key
✓ CyberPower	CyberPower V3	cyber snmpv3 user1	None		None	
✓ APC	apc v3	apc snmp profile1	MDS	*****	DES	*****
✓ EATON	eaton v3	readwrite	SHA	*****	AES	*****

SNMPv1 and SNMPv3 settings on SNMP Configurations page

3.2.3.2.1 CyberPower

SNMPv1

SNMP Community. PowerPanel Business Management uses this community to authenticate communication between the PDU and UPS in order to access their information. The default community is **private**. By default, the UPS/PDU/ATS uses **private** as the community with write permission, and **public** with read only permission. The community used by PowerPanel Business Management to access the UPS/PDU/ATS must have write permission for an administrative power control.

SNMP Trap Community. PowerPanel Business Management uses this community to authenticate SNMP traps from the monitored PDU and UPS RMCARD. The community default is **public**. The IP address of the Management computer must be added to the Trap Receiver list on the **Network/Trap Notification** page of the UPS RMCARD and the PDU to ensure that the communities match.

Note: The community can be configured on the **Network/Access Control (or Network Service/SNMPv1 Service)** page in the UPS remote management card (RMCARD) web or on the **Network/SNMP Settings (or Network Service/SNMPv1 Service)** page in the PDU web.

Note: The SNMP community is limited to 15 characters in the PDU and UPS RMCARD.

Note: If you have firewall software installed, configure the settings to allow access through port 3052 (UDP/TCP), port 53568 (TCP), port 162 (UDP) and port 53566(UDP). These ports must open because PowerPanel Business Management uses them to establish the communication with PDU and UPS RMCARD.

SNMPv3

PowerPanel Business Management will use the below SNMPv3 settings to interact with a secure device. These settings can be configured on the **SETTING/Network Configurations/SNMP Configurations** page of PowerPanel Business Management and on the **Network Service/SNMPv3 Service** page of the UPS RMCARD/PDU/ATS. These settings must match.

- **User Name:** Specifies a username match for protocol.
- **Authentication Protocol:** Sets the protocol to be used for authenticating the network communication between PowerPanel Business Management and devices.
- **Authentication Key:** Sets the authentication key which is used for the authentication protocol.
- **Privacy Protocol:** Sets the privacy protocol to be used for encrypting data during transmission between PowerPanel Business Management and devices.
- **Privacy Key:** Sets the privacy key to encrypt data for the authentication privacy protocol.

3.2.3.2.2 Other MIBs

SNMPv1

SNMP Community: PowerPanel Business Management uses this community to authenticate communication with a UPS that supports APC's and Eaton's SNMP MIB profiles in order to access their information. By default, the UPS uses **private** as the community with write

permission, and **public** with read only permission. The community used by PowerPanel Business Management to access the UPS must have write permission for administrative power control.

SNMP Trap Community: PowerPanel Business Management uses the community to authenticate the SNMP trap from the monitored UPS that supports APC's and Eaton's SNMP MIB profiles. The community default is **public**. The IP address of the Management computer must be added to the Trap Receiver list on the **SNMPv1** setting page of APC's and Eaton's UPS network card to ensure that the community match.

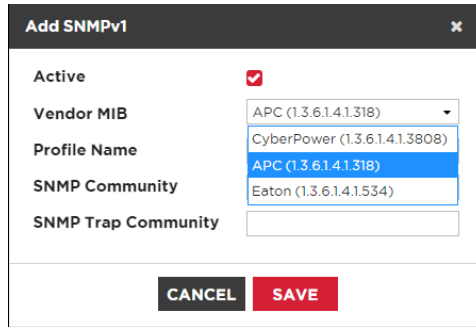

Add Other SNMPv1 MIB File

SNMPv3

PowerPanel Business Management will use the below SNMPv3 settings to interact with a secure device. These settings can be configured on the **SETTING/Network Configurations/SNMP Configurations** page of PowerPanel Business Management and on the **SNMPv3** setting page of the APC's and Eaton's UPS network card. These settings must be matched.

- **User Name:** Specifies a username match for protocol.
- **Authentication Protocol:** Sets the protocol to be used for authenticating the network communication between PowerPanel Business and devices.
- **Authentication Key:** Sets the authentication key which is used for the authentication protocol.
- **Privacy Protocol:** Sets the privacy protocol to be used for encrypting data during transmission between PowerPanel Business and devices.
- **Privacy Key:** Sets the privacy key to encrypt data for the authentication privacy protocol.

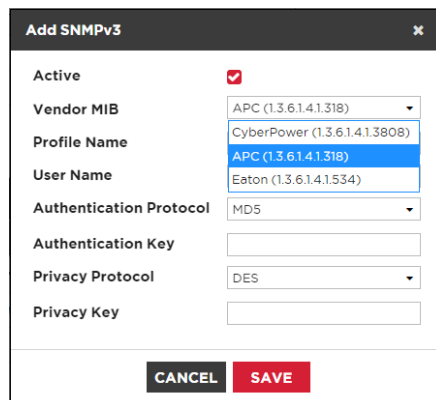

Add Other SNMPv3 MIB File

3.2.3.3 Auto-Discover Range

In order to search devices and computers in different segments or a specific range, users can set IP range on this page.

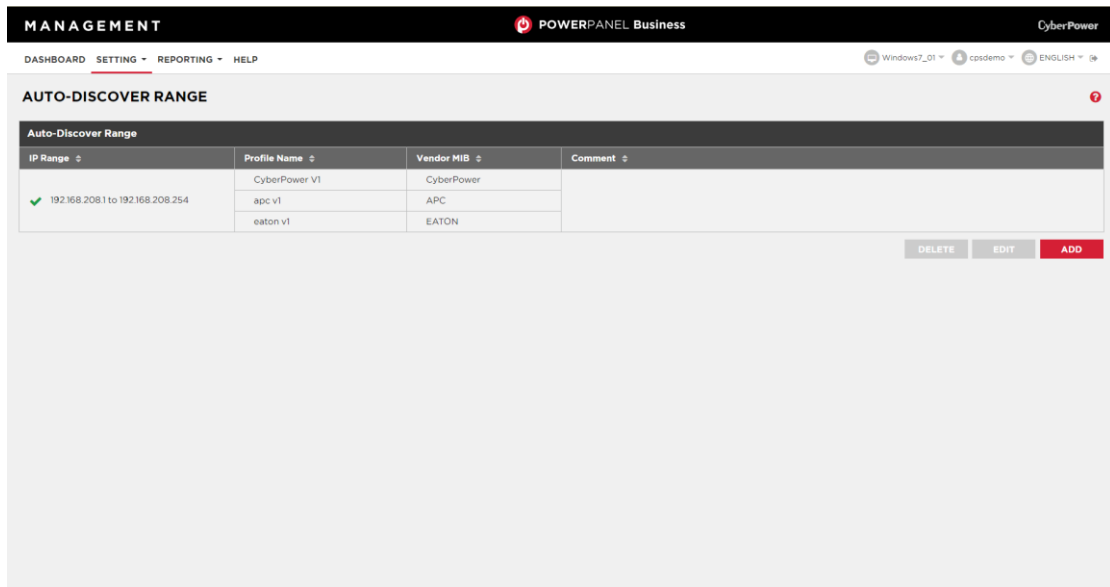

SETTING/Auto-Discover Range page

IP ranges can be managed as follows:

- **Add a new IP range:** Click the **ADD** button and an **Add IP Range** dialog will appear. Select the **Profile Name**, enter all required data, and click the **SAVE** button to add a new IP range to the list.

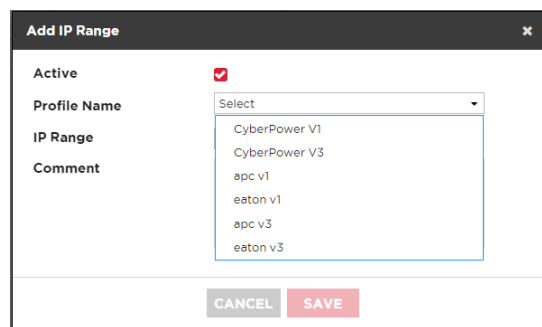

Add a new IP range

- **Modify the IP range:** Select the IP range you wish to modify and click the **EDIT** button. After entering in the new data, click the **SAVE** button to complete.
- **Remove the IP range:** Select the IP range to remove from the IP range list, and then click **DELETE** to complete the IP range deletion.

The IP range detail settings and descriptions are explained below:

- **Active:** States if the IP range is active.
- **IP Range:** Set the range used in scanning for devices and computers.

- **Comment:** Sets the user-defined comments for this IP range.

3.2.3.4 Security

3.2.3.4.1 PowerPanel Secret Phrase

The Secret Phrase is used to create secure network communications between PowerPanel Applications such as Remote and Local, Remote and UPS RMCARD, or Remote and PDU. The default phrase is **powerpanel.encryption.key**. The Secret Phrase can be configured on the **SETTING/Security** page in the Local and Remote, or on the **System/Authentication** page in the PDU and UPS RMCARD web interface. The Secret Phrase which is used in the Remote and devices must match.

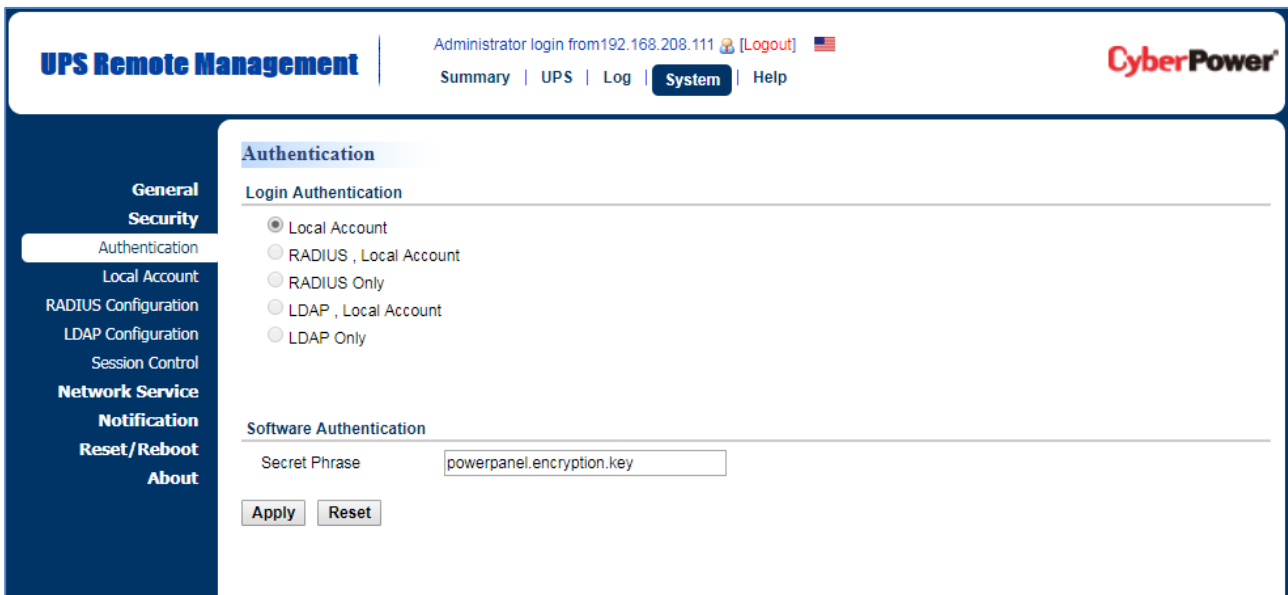

Secret Phrase on the System/Security page in the UPS RMCARD205 web

3.2.3.4.2 SSL Certificates

Import SSL Certificates

The user's browser that connects with the PowerPanel Business web interface will serve the SSL certificate. The certificate proves to the browser that the provider believes that it has issued a certificate to the owner of the PowerPanel Business. The **SSL Certificates** section allows users to import your own SSL certificate and *SSL Certificate* displays the date and result for the last time to import SSL certificates. Users can import the certificates as following steps:

- Prepare a **.key** file and a **.crt** file.
- Open Command Prompt in Windows. Move to the folder which contains **.key** and **.crt** files.
`cd D:\.....`
- Enter command:

```
openssl pkcs12 -inkey yourfilename.key -in yourfilename.crt -export -out yourfilename.pkcs12
```

Note: Make sure the user has OpenSSL in the computer.

Note: Enter the actual file names to replace `yourfilename`.

- Set *Key Passphrase* and *Keystore Password*.

Note: It is recommended to set *key passphrase* and *keystore password* as the same one.

- `yourfilename.pkcs12` file is generated in the folder.
- Go to **Setting/Network Configurations/Network Configurations/HTTPs** page, tick **HTTPs Secure**, and click the **APPLY** button.
- Go to **Setting/Network Configurations/Security** page. Click the **IMPORT** button to start the *SSL Certificates Wizard*.



Import SSL certificate

- Upload the SSL certificate file `yourfilename.pkcs12`.
- Enter the *Key Passphrase* field and the *Keystore Password* field. Click the **IMPORT** button to import the SSL certificates

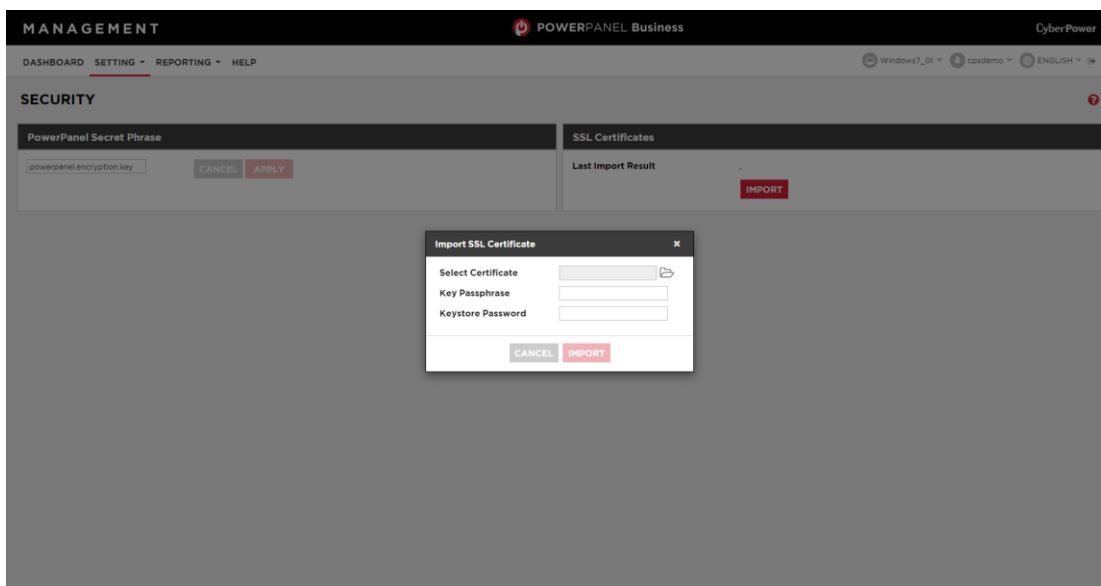

Select SSL certificate

Note: Applying for a certificate from the commercial certificate provider will be subject to the provider fee.

Add SSL Certificate into Trust List

A certificate trust list is a pre-defined list of SSL certificates that have been signed by a trusted entity. A certificate trust list of PowerPanel Business is used to identify the certificate authority of another one with whom interacts. When importing a new SSL certificate, this will result in communication loss between the Local, Remote and Management.

As an example, when the Remote that has been connected with the Local imports a new SSL certificate, the Client cannot interact with the Local. Users must to add the certificate of Remote into the trust list of the Local manually and thus the Local considers the Remote's SSL certificate valid.

Users can follow the steps to add the certificate into the trust list - Remote and Local, for example:

- Place the SSL certificate of the Remote as file extension of **.crt** in the `<Local_installation_directory>/jre/lib/security`.
- Switch to the `<Local_installation_directory>/jre/lib/security` directory in the command prompt.
`cd <Local_installation_directory>/jre/lib/security`
- Run the below command to add the certificate to the trust list.
`<Local_installation_directory>/jre/bin/keytool.exe -import -trustcacerts -file <cert_name>.crt -alias <alias_name> -keystore cacerts.`
- Enter “*changeit*” as the password for the certificate addition.
- Enter “y” to apply the certificate addition.
- Restart the Local service to reload the trust list and take effect. Refer to **How to restart PowerPanel Business service** of **FAQ** chapter for further details about how to restart PowerPanel Business service.

Note: **Local_installation_directory** is the directory where the PowerPanel Business Local installation locates; **cert_name** is the filename of the certificate file and **alias_name** is the alias for the certificate available in the trust list.

Note: The above mentioned steps are applicable to the interactions between PowerPanel Business software.

Note: Due to security reasons, user may have to change the password to access the trust list. Refer to **How to change the password to access the trust list**.

3.2.4 Notifications

3.2.4.1 Notifications

An event is generated when the UPS/PDU/ATS encounters specific power conditions. The Management can monitor multiple power devices and computers and can be configured to notify users based on the event. The **SETTING/Notifications** page lists events and divides these events into several categories. Each event is allowed to configure the individual notification settings. The severity of each event is marked by a symbol.

The administrator can be notified when an event occurs. See **SETTING/Notification Channels** page for more details about the notification methods and recipient assignment. Use these parameters bellow to configure actions for individual events.

- **Send:** Determines whether to send a notification or not and sets the notification delay. If the event is cleared within the notification delay, the notification of the occurrence and the event cleared notification will not be sent.
- **Repeat:** Determines whether to send one additional notification after the initial notification. Only events which are of severe-level and warning-level type support a repeat notification.

3.2.4.2 Notification Channels

The administrator can be notified when an event occurs. In **SETTING/Notification Channels** page, users can configure several notification methods.

3.2.4.2.1 E-mail

Users will receive event notification instantly when the required fields are filled in.

The screenshot shows a configuration window titled "E-mail". It contains the following fields and options:

- Enabled:** A checked checkbox.
- SMTP server address:** A text input field containing "smtp.gmail.com".
- Connection Security:** Radio button options for "TLS", "SSL", "None", "1.0", "1.1", "1.2", and "Auto". "Auto" is selected.
- Service port:** A text input field containing "587" and a label "Default port: 587".
- Sender name:** A text input field containing "PowerPanel Business".
- Sender E-mail:** A text input field containing "ppbtest@cyberpower.co".
- Authentication:** A checked checkbox.
- User Name:** A text input field containing "ppbtest@cyberpower.co".
- Password:** A text input field with masked characters ".....".

At the bottom of the form are two buttons: "TEST" and "APPLY".

Email service

- **Enabled:** Click to enable PowerPanel Business to send email notifications.
- **SMTP server address:** Fill in the SMTP server used to send email notifications to the recipient.
- **Connection Security:** Select the secure connection for the SMTP service to send email notifications.
- **Service port:** Fill in the port number used by the SMTP service.
- **Sender name & Sender E-mail address:** Fill in the sender' s name and e-mail address shown in email notifications.
- **Authentication:** Click to authorize the SMTP server to verify the User Name and Password listed below.
- **Username:** Fill in the account to access the SMTP server.
- **Password:** Fill in the password to access the SMTP server.

3.2.4.2.2 Short Message Service (SMS)

Short Message Service (SMS) is a communication service used by mobile communication systems, using standardized communications protocols allowing the interchange of short text messages between mobile devices.

The Local/Remote sends mobile text messages to a receiver's mobile phone using an online SMS service. Users can choose **Clickatell** as a platform to send SMS or choose any SMS provider which sends a message via E-mail or HTTP. All account information and E-mail/HTTP specification must be acquired from the service provider before using SMS. The different SMS providers are described below:

- **Provider is Clickatell:**

Select the **Clickatell** option at the *Service Provider* field.

One-Way Message: Complete the **HTTP API ID** field if users are from the area other than North America.

Two-Way Message: Complete both the **HTTP API ID** and **Sender Phone Number** fields if users are from North America.

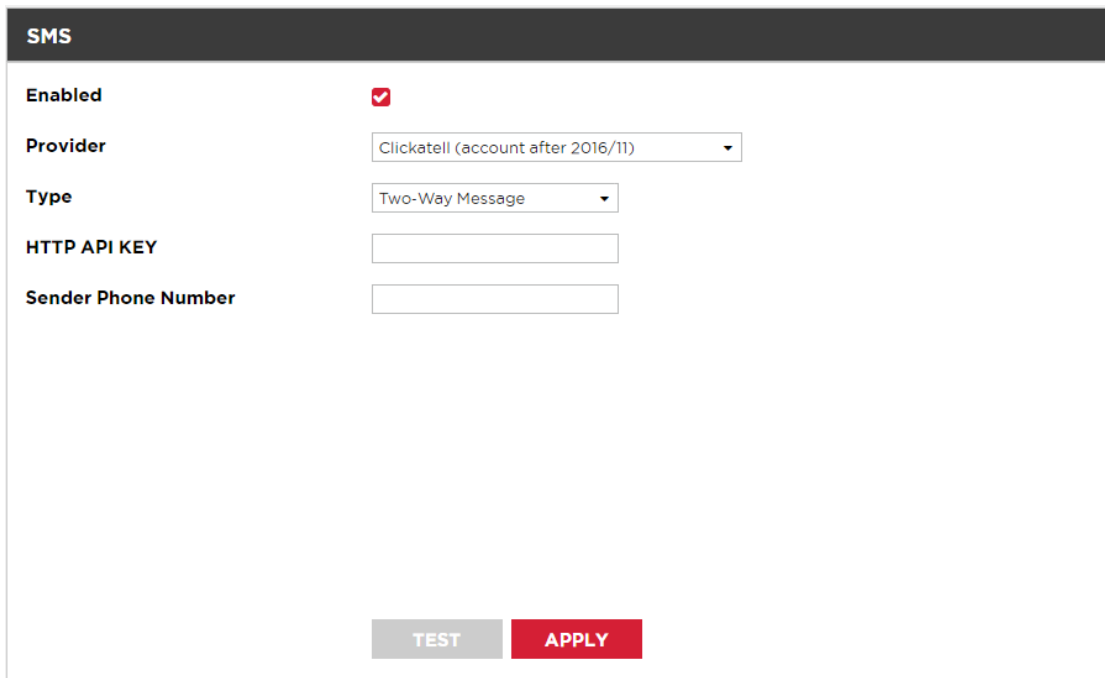

The screenshot shows a configuration form for SMS. The form has a dark header with the text 'SMS'. Below the header, there are several fields: 'Enabled' with a checked checkbox, 'Provider' with a dropdown menu showing 'Clickatell (account after 2016/11)', 'Type' with a dropdown menu showing 'Two-Way Message', 'HTTP API KEY' with an empty text input field, and 'Sender Phone Number' with an empty text input field. At the bottom of the form, there are two buttons: 'TEST' (grey) and 'APPLY' (red).

SMS (Short Message Service) service

- **Provider accepts HTTP POST to send messages:**

This specification from an SMS provider is required before using the HTTP POST method to deliver messages to SMS providers. Select the Using HTTP POST option at the *Service Provider* field. Insert **EVENT_ACTION_PHONE_NUMBER** as recipient's mobile phone number and **EVENT_ACTION_MESSAGE** as the event message content described in the specification, and fill in the *URL* and *POST BODY* fields. The expressions will be replaced by the relevant content before the Local/Remote sends a notification to the SMS provider.

e.g.

URL: `http://send-sms-company.com/sms`

POST Body: `user=xxxxxx&password=xxxxxx &to=EVENT_ACTION_PHONE_NUMBER
&text=EVENT_ACTION_MESSAGE`

- **Provider accepts *HTTP GET* to sends messages:**

This specification from the SMS provider is required before using the HTTP GET method. Select the **Using HTTP GET** option at the Service Provider field. Insert the **EVENT_ACTION_PHONE_NUMBER** as recipient's mobile phone number and the **EVENT_ACTION_MESSAGE** as event message's content described in the specification, and fill in the *URL* field. The expressions will be replaced by relevant content before the Local/Remote sends a notification to SMS provider.

e.g.

URL: `http://send-sms-company.com/sms?user=xxxxxx&password=xxxxxx`

`&to=EVENT_ACTION_PHONE_NUMBER&text=EVENT_ACTION_MESSAGE`

- **Provider accepts *E-mail* to send messages:**

This specification from an SMS provider is required before using the E-mail to deliver the messages to SMS providers. Select the **Using E-mail** option at the *Service Provider* field. Insert **EVENT_ACTION_PHONE_NUMBER** as recipient's mobile phone number and the **EVENT_ACTION_MESSAGE** as event message content described in the specification. Fill in the *Address*, *Subject* and *Content* fields. The expressions will be replaced with relevant content before the Local/Remote sends a notification to the SMS provider.

e.g.

Address: `sms@send-sms-company.com`

Subject: `xxxxxx`

Content: `user:xxxxxx`

`password:xxxxxx`

`to:EVENT_ACTION_PHONE_NUMBER`

`text:EVENT_ACTION_MESSAGE`

Note: Each message sent by the SMS system through the SMS provider will be subject to the SMS provider fee.

3.2.4.2.3 XMPP Instant Messaging

The XMPP (Extensible Messaging and Presence Protocol) is an open protocol for instant messaging. Users can setup the configuration to receive instant messages when an event has occurred. Users may contact a network administrator to verify if there is a XMPP Instant Messaging server in the network. A local network XMPP Instant Messenger server can be setup by downloading open source XMPP Instant Messenger server software, such as **Openfire**. More server software information can be found on [XMPP server software list](#).

XMPP Instant Messenger service

To use XMPP Instant Messaging, users must provide a unique XMPP Instant Messaging Service account as a sender and assign different account as a receiver on **Event Action/Notification Recipient** page.

- **Enabled:** Specifies whether the Local/Remote XMPP Instant Messaging service to notification is active or inactive.
- **Service address:** Sets the XMPP server address according to your XMPP Server configuration.
- **Service name:** Sets the service name on an XMPP Instant Messaging server. This option is usually not required. Contact the systems administrator of the server for the service name if required.
- **Service port:** The port number which the XMPP Instant Messaging server will use.
- **Username:** Sets the account to access the XMPP Instant Messaging server.
- **Password:** Sets the password for the account.

Note: In order to make sure that the sender can send the XMPP notification to recipients, recipients should accept the invitation from sender.

3.2.4.2.4 Remote Desktop Services

Remote Desktop Services

Remote Desktop Service only works on Windows platforms. Options are explained below:

- **Enabled:** Specify whether to use this service to send a notification to recipients.

3.2.4.3 Recipients

PowerPanel Business Management can send notifications to multiple recipients in various ways, including Windows Alert Messages, Instant Messages and mobile phone text messages (SMS). The **Notification Recipient** page lists all recipients in the recipient list and displays all defined notifications and whether the notification is active.

RECIPIENTS						
All Recipients						
Name	E-mail	XMPP	RDS Alert	SMS	Active Days	Active Times
✓ Default Receiver	✗	✗	✗	✗	Su,M,Tu,W,Th,F,Sa	00:00 - 00:00
✓ Tony	✓	✓	✗	✓	Su,M,Tu,W,Th,F,Sa	00:00 - 00:00
✗ Doris	✓	✗	✓	✗	Su,M,Tu,W,Th,F,Sa	00:00 - 00:00
✓ Tim	✓	✓	✓	✓	Su,M,Tu,W,Th,F,Sa	00:00 - 00:00

Notification/Recipient page

Recipients can be managed as follows:

- **Add a new recipient:** Click the **ADD** button to open the Add Receiver dialog. Enter all required data and click the **SAVE** button to add a new recipient to the list.
- **Modify the recipient:** Select the recipient you wish to modify and click **EDIT** button. After entering in the new data, click the **SAVE** button to complete.
- **Remove the recipient:** Select the recipient to remove from the recipient list, and then click **DELETE** button to complete the recipient deletion.

The recipient detail settings and descriptions are explained below:

- **Active:** States if the recipient is active.
- **Language:** The language to which the recipient prefers. The notification sent to this recipient uses this language to display content.
- **Recipient Name:** The name of the recipient. The recipient’s name must be unique.
- **E-mail Address:** The E-mail address of the recipient.
- **XMPP Account:** The XMPP Instant Messaging account of the recipient. See **SETTING/Notification Channels** for more details about XMPP.
- **Computer Username:** The computer user account name which is used to receive the windows alert messages. Due differences in the Messenger Service of different versions of Windows, please refer to the descriptions below:
 - If PowerPanel Business and the recipients are on **Windows 7, Windows Server 2012** or **Windows 8**, and then the alert messages will only be sent to a local user account on the computer running PowerPanel Business.

Note: Computer Name field and Alert column are only available on the PowerPanel Business which installed on Windows.

- **Mobile Phone Number:** The mobile number of the recipient to receive the mobile text message. It must contain the country code.
- **Active Days:** Configures the days on which recipients can receive the notification. Users can define the specific ways to notify the assigned administrators on different days.
- **Active Time:** Configures the time which recipients will receive the notification. Users can define the specific ways to notify the assigned administrators during different times.
- **Enabled:** Displays which notification(s) are active for the recipient.
- **Test:** Sends the notification in accordance with current settings in order to verify the function. The service can be tested only when the corresponding service on the Event Action/Settings page is configured as activated.

3.2.5 VMware vSphere Shutdown Settings

3.2.5.1 Shutdown Events

An event is generated when the UPS/PDU/ATS encounters specific power conditions. The **SETTING/VMware vSphere Shutdown Settings/Shutdown Events** page lists events that can be configured to shut down ESXis. A shutdown sequence is only initiated by events specific for the target ESXi host.

- **Shutdown:** Determines whether to request the target ESXi host to be shut down and the delay before initiating the shutdown sequence. The shutdown will be canceled if the event is cleared during this delay time. The minimum delay time to initiate shut down is based on the time set for the execution of the notification to complete. This includes the notify delay time.
- **Multiple Configurations:** The configuration of shutdown events will be applied to all devices selected under PPB Management. If user wants multiple setups of configuration, paid license will be needed. Click **Add** icon on upper right.



3.2.5.2 Power Source

To assign the power source to the vCenter server/VM, select it from the drop-down list and assign the correct UPS outlet used by the vCenter server/VM and click **SAVE** to continue.

The screenshot shows the 'Power Supply Configuration' page. At the top, there is a 'Redundant Power Supply Policy' dropdown menu set to '2(1+1)'. Below this, there are two columns for 'Power Supply #1' and 'Power Supply #2'. Each column contains three dropdown menus: 'Device Type' (set to 'UPS'), 'UPS Address' (set to 'RMCARD205 (192.168...'), and 'UPS Outlet' (set to '1'). Below each column is a green status bar that says 'Communication established.'. At the bottom right of the page, there is a red 'SAVE' button.

3.2.5.3 Shutdown Trigger Event

Next, select **Shutdown Trigger Event** from UPS/PDU/ATS. Shutdown will be conducted according to the configuration of *Shutdown Trigger Event* and **VMware Shutdown Command Configuration**. Click **SAVE** to continue.

Shutdown Trigger Event		
UPS	ATS	PDU
Trigger	Urgency	Event
<input type="checkbox"/>	!	Battery capacity is critically low
<input type="checkbox"/>	!	Remaining runtime will be exhausted
<input type="checkbox"/>	!	The output power is going to stop soon
<input type="checkbox"/>	!	Network communication lost with UPS in a power event
<input type="checkbox"/>	!	System is overheated
<input type="checkbox"/>	!	Network communication lost
<input type="checkbox"/>	!	UPS is faulty
<input type="checkbox"/>	!	Utility power failure
<input type="checkbox"/>	!	Batteries are not present
<input type="checkbox"/>	!	Available runtime is insufficient
<input type="checkbox"/>	!	Output is off
<input type="checkbox"/>	!	UPS fatal internal abnormality
<input type="checkbox"/>	!	Power consumption is too high
<input type="checkbox"/>	!	Power consumption is too low

SAVE

Shutdown Trigger Event

The next step is to assign the shutdown behavior. Check Shutdown and Command accordingly; enter corresponding required time to execute the shutdown and command. Click **SAVE** when the settings are done

VMware Shutdown Command Configuration						
Name	IP	Shutdown	Shutdown Delay	Active Command	Command	Command Delay
▶ localhost.localdomain	192.168.208.238	<input type="checkbox"/>	<input type="text"/> sec.	<input type="checkbox"/>	<input type="text"/>	<input type="text"/> sec.
▼ VMware vCenter Server	192.168.20.249	<input type="checkbox"/>	<input type="text"/> sec.	<input type="checkbox"/>	<input type="text"/>	<input type="text"/> sec.
▼ not_vSan_Cluster						
192.168.20.247	192.168.20.247	<input type="checkbox"/>	<input type="text"/> sec.	<input type="checkbox"/>	<input type="text"/>	<input type="text"/> sec.
192.168.20.248	192.168.20.248	<input type="checkbox"/>	<input type="text"/> sec.	<input type="checkbox"/>	<input type="text"/>	<input type="text"/> sec.
New Virtual Machine6		<input type="checkbox"/>	<input type="text"/> sec.	<input type="checkbox"/>	<input type="text"/>	<input type="text"/> sec.
P08-VC1		<input checked="" type="checkbox"/>	500 sec.	<input checked="" type="checkbox"/>	default	200 sec.
192.168.20.55	192.168.20.55	<input type="checkbox"/>	<input type="text"/> sec.	<input type="checkbox"/>	<input type="text"/>	<input type="text"/> sec.
P08-VC	192.168.20.249	<input type="checkbox"/>	<input type="text"/> sec.	<input type="checkbox"/>	<input type="text"/>	<input type="text"/> sec.
vSphere_Replication		<input type="checkbox"/>	<input type="text"/> sec.	<input type="checkbox"/>	<input type="text"/>	<input type="text"/> sec.
P08-Esxi-A		<input type="checkbox"/>	<input type="text"/> sec.	<input type="checkbox"/>	<input type="text"/>	<input type="text"/> sec.
P08-Esxi-B		<input type="checkbox"/>	<input type="text"/> sec.	<input type="checkbox"/>	<input type="text"/>	<input type="text"/> sec.

SAVE

VMware Shutdown Command Configuration

3.2.5.4 Account Management

After all setting details are checked and confirmed correct, go to **Settings - Account Management** to make sure the action log is correct.

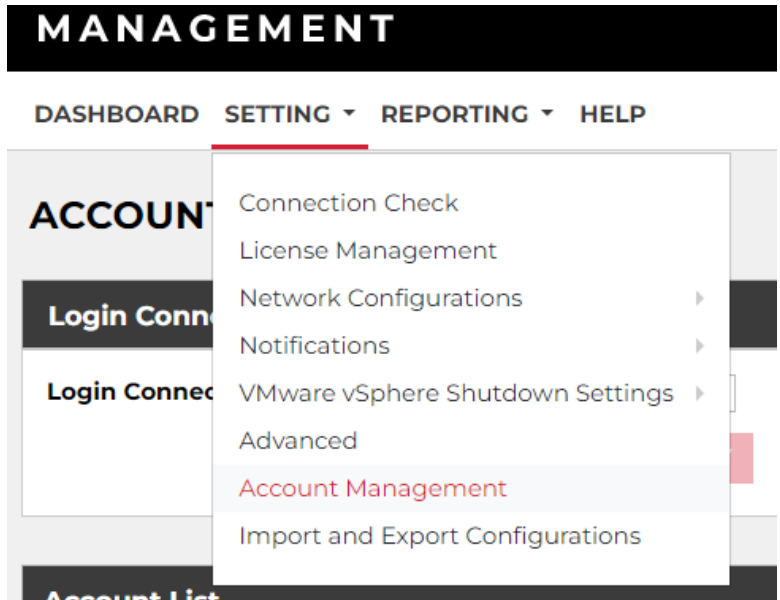

Path of Account Management

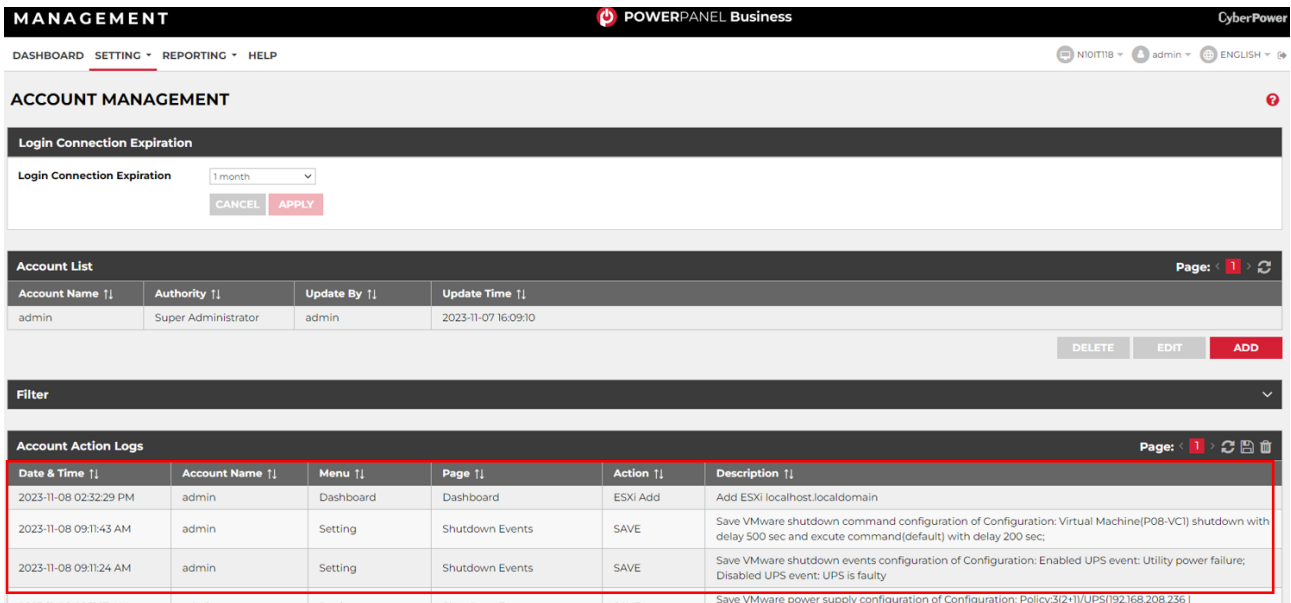

Confirm the actions are successful from Account Action Logs

3.2.6 Advanced

3.2.6.1 Command Scripts

The PowerPanel Business Management software can be configured to respond to specific events and perform command execution. The **SETTING/Advanced** page lists events that can be set to perform command execution. For details of each event, please refer to **Event Details** section.

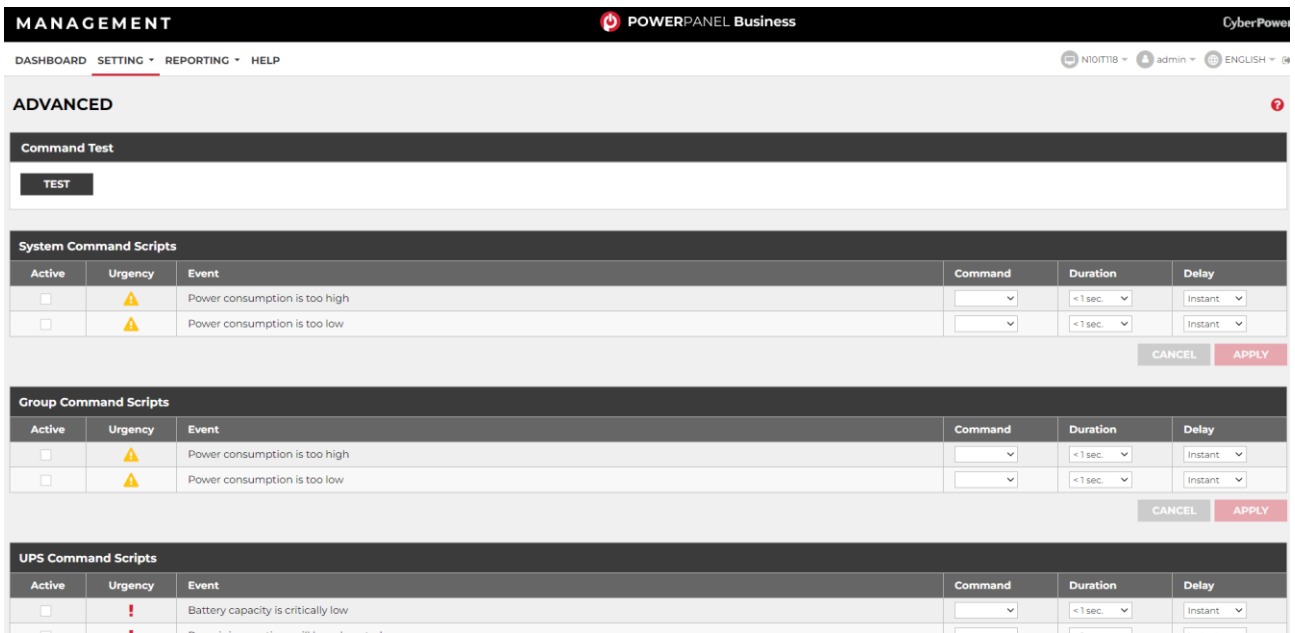

SETTING/Advanced page

The severity of each event is marked by a symbol. Severe level (!) indicates users must be alerted and the computer shut down to avoid an improper shutdown. Warning level (⚠) indicates a warning and users should be notified when it occurs. If a warning condition persists, a system shutdown may be imminent. Information level (i) indicates the state of the UPS or that the utility power condition has changed.

A command will be executed when an event occurs.

- **Active:** Determines whether to execute a command. If the check box is unchecked, the command for this event and the corresponding event will not be executed.
- **Command:** Sets a command file to be executed when an event occurs. Shell scripts for the command file uses "cmd" as the filename extension. For more information about shell scripts read the detailed description in the "default.cmd" file in the "extcmd" folder in the PowerPanel Business installation directory. Customized shell scripts must be saved in the "extcmd" folder in the PowerPanel Business installation directory. The command file will be listed on the *Command/File* list and can be executed when the power event occurs.
Note: The command file name will be displayed in italics if the command file which had used cannot be found in the "extcmd" folder.
- **Duration:** Sets the estimated time for the command to complete. If the event requires the computer to shut down, this delay provides time for commands and scripted actions to complete before the shutdown is initiated.
- **Delay:** Determines whether to execute a command and sets the delay for the command execution. If the event is cleared within the command execution delay, the command for this event and the corresponding event will not be executed.

The following environment variables can be placed in external commands to identify which event and which stage to be executed.

- **%EVENT_STAGE%:** Indicates what stage of firing event to execute the commands. When an event first happens, it enters the **OCCUR** stage and the assigned commands will be executed. When an event is ended, the variable will be **FINISH** and the assigned commands will be executed.
- **%EVENT%:** Indicates which event is fired to execute the commands.
- **%EVENT_CONDITION%:** Indicates which the detailed event condition of a firing event.
- **%MODULE_NO%:** Indicates which UPS module on a firing event. This variable is used on Modular UPS models.

The following table lists all details of **%EVENT%** and **%EVENT_CONDITION%** variables.

%EVENT%	%EVENT_CONDITION%	Event Name
BATTERY_CRITICAL_LOW		Battery capacity is critically low.
ENTER_BYPASS		Enters bypass mode.
BATTERY_EXHAUSTED		Battery has been depleted.
EMERGENCY_OFF		EPO is active.
BATTERY_FULL		Battery is fully charged.
SHUTDOWN		Shutdown initiated.
BYPASS_FAILURE		Bypass power source has failed.
CAPACITY_INSUFFICIENT		Insufficient inverter capacity.
LOSS_REDUNDANT		Not enough power redundancy modules.
ABNORMAL		UPS input abnormality.
	NO_NEUTRAL	No neutral input.
	WIRING_FAULT	Site wiring fault.
FATAL_ABNORMAL⁴		UPS fatal internal abnormality.
	OUTPUT_OVERLOAD	Output is overloaded.
	BYPASS_OVERLOAD	Bypass is overloaded.
	MODULE_OVERLOAD	Module is overloaded.
	SHORT_CIRCUIT	Output circuit-short.
	MODULE_RECTIFIER_OVERHEAT ¹	Module rectifier is overheated.
	MODULE_INVERTER_OVERHEAT ¹	Module inverter is overheated.
	MODULE_INVERTER_PROTECTED ¹	Module inverter is protected.
	BATTERY_REVERSED	The polarity of battery is reversed.
	BYPASS_SEQUENCE_ERROR	The phase sequence of bypass is wrong.

COMMUNICATION_FAILURE⁴	LOST_IN_LOCAL	Local communication lost.
	LOST_IN_NETWORK ³	Network communication lost.
FAULT⁴	GENERIC_FAULT	UPS is faulty.
	BYPASS_FAN_FAULT	Bypass fan is faulty.
	BYPASS_FAULT	Bypass is faulty.
	MODULE_RECTIFIER_FAULT ⁷	Module rectifier is faulty.
	MODULE_INVERTER_FAULT ⁷	Module inverter is faulty.
MODULE_FAN_FAULT ⁷	Module fan is faulty.	
NO_BATTERY		Batteries are not present.
RUNTIME_INSUFFICIENT		Available runtime is insufficient.
UTILITY_FAILURE		Utility power failure.
URGENT_COMMUNICATION_FAILURE²	LOST_IN_LOCAL	Local communication lost in a power event.
	LOST_IN_NETWORK	Network communication lost in a power event.
RUNTIME_WILL_EXHAUST		Remaining runtime will be exhausted.
OUTPUT_WILL_STOP		The output power is going to stop soon.
INPUT_NEAR_OVERLOAD²		Input is near overload.
INPUT_OVERLOAD²		Input is overloaded.
SHUTDOWN_TIME_INSUFFICIENT²		Shutdown time is insufficient.
ATS_FAULT⁵		ATS is faulty.
ALL_SOURCE_FAILURE⁵		Both input sources have power loss, ATS will not change input source
CURRENT_SOURCE_FAILURE⁵		ATS has automatically switched to redundant power source.
REDUNDANT_SOURCE_FAILURE⁵		ATS redundant power source has experienced a power failure.
ENV_SENSOR_LOST⁶		Environmental sensor is not responsive.
ENV_SENSOR_OVERHEAT⁶		Temperature is over the high threshold.
ENV_SENSOR_UNDERCOOL⁶		Temperature is under the low threshold.
ENV_SENSOR_OVERWET⁶		Humidity is over the high threshold.
ENV_SENSOR_OVERDRY⁶		Humidity is under the low threshold.

POWER_LOST	Power supply redundancy has been lost.
MBO_OUTLET_OVERLOAD⁷	A PDU outlet is overloaded.
MBO_OUTLET_NEAR_OVERLOAD⁷	A PDU outlet is near overload.

¹: This event only occurs for the Modular UPS in Local.

²: This event only occurs for the PDU in Remote.

³: This event only occurs in Remote.

⁴: This **%EVENT%** variable must come with a **%EVENT_CONDITION%** variable.

⁵: This event only occurs for the ATS in Remote.

⁶: This event only occurs for the environmental sensor for UPS/PDU/ATS in Remote.

⁷: This event only occurs for the Metered by Outlet PDU in Remote.

3.2.7 Account Management

3.2.7.1 Session

The **Session Timeout** section is the option which determines the duration of the session after the login. If the page isn't accessed during this period and remains inactive, users will be logged out automatically. Users will need to login again.

3.2.7.2 Account List

- **Account Name:** Accounts of users in PowerPanel Business Management.
- **Authority:** The authority of this account. PowerPanel Business Management uses three levels of authority, including Super Administrator, Administrator, and User to perform management tasks. Each authority can access different system tasks. Three levels of authority are described in below table.

Menu	Page/Function	Authority		
		Super Administrator	Administrator	User
Dashboard	View	✓	✓	✓
Dashboard	Add & Control Device	✓	✓	
Setting	All pages	✓	✓	
Report	All pages	✓	✓	✓
Report	Setting & Delete	✓	✓	
Help	All pages	✓	✓	✓

Note: An authority can only add, modify authority level and delete an authority whose level is lower than itself.

- **Update By:** The account that built or edited this account.
- **Update Time:** The time this account was created or edited.

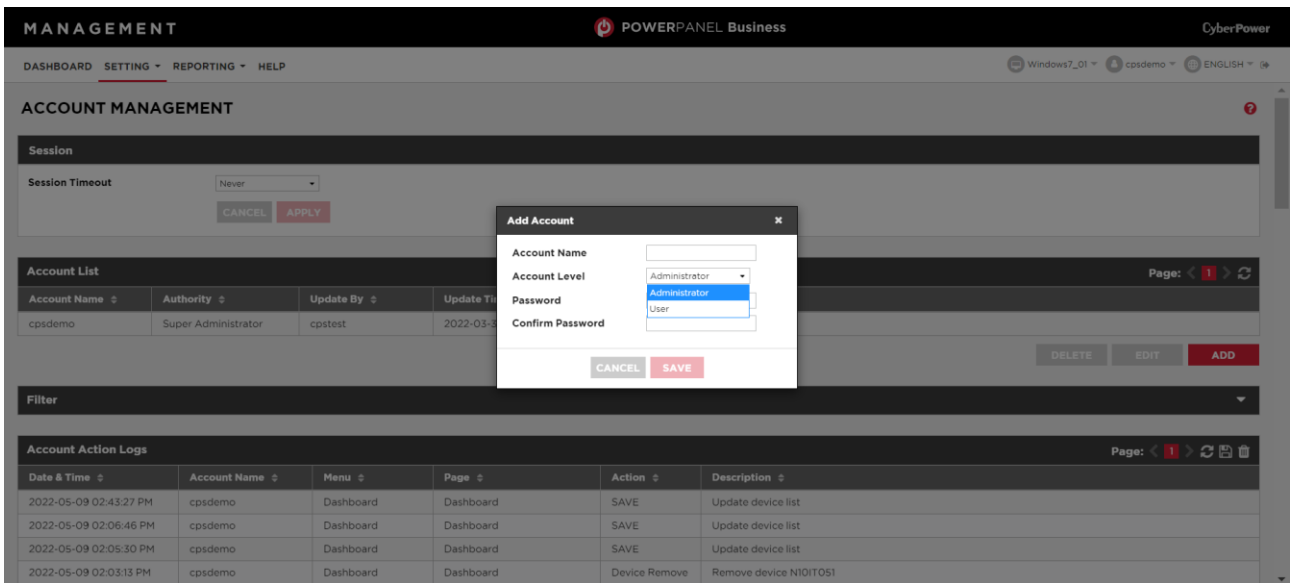

Set Authority Page

3.2.7.3 Filter

The **Filter** section allows filtering of the account action logs.



Filter pane on SETTING/Account Management page

- **Dates:** Select the Dates for the account action logs to be displayed.
- **Times (Hours):** Select the time range for the account action logs to be displayed.
- **Records Per Page:** Specify the number of records to show per page.

3.2.7.4 Account Action Logs

The **Account Action Logs** section records action logs of each account.

Date & Time	Account Name	Menu	Page	Action	Description
2020-02-15 11:36:33 AM	admin	Setting	Account Management	EDIT	Edit account aa
2020-02-15 09:43:39 AM	admin	Dashboard	Dashboard	Group Add	Add group aa
2020-02-15 09:28:44 AM	admin	Dashboard	Dashboard	SAVE	Update device list
2020-02-15 09:28:41 AM	admin	Dashboard	Dashboard	vCenter Add	Add vCenter VMware vCenter Server
2020-02-15 09:28:16 AM	admin	Dashboard	Dashboard	vCenter Remove	Remove vCenter VMware vCenter Server
2020-02-15 09:28:07 AM	admin	Dashboard	Dashboard	vCenter Add	Add vCenter VMware vCenter Server
2020-02-15 09:27:05 AM	admin	Dashboard	Dashboard	vCenter Add	Add vCenter VMware vCenter Server
2020-02-15 09:27:05 AM	admin	Dashboard	Dashboard	ESXi Add	Add ESXi localhost.localdomain
2020-02-14 04:31:57 PM	admin	Setting	Account Management	ADD	Add account aa
2020-02-14 09:13:02 AM	admin	Setting	Advanced	IMPORT	Import profile
2020-02-13 02:47:56 PM	admin	Setting	Advanced	IMPORT	Import profile
2020-02-12 02:13:56 PM	admin	Setting	Account Management	ADD	Add account user
2020-02-12 01:46:36 PM	admin	Dashboard	Dashboard	SAVE	Update device list

Account Action Logs page

Clicking the **Previous** and **Next** at the upper right corner of the account action log table allows users to view the other range of filtered log result backward or forward. Clicking **Refresh** will update the log result according to the current filter options and page settings.

Export

Click the **Save**  shortcut at the upper right corner of the account action log table and select **CSV** or **PDF** file as the export file format. The exported file will be saved in the default download directory of your web browser.

Clear All Logs

Click the **Delete**  shortcut at the upper right corner of the account action log table. A dialog box will show, saying all account action logs will be removed immediately after clicking **DELETE**. The log clearance is permanent and once applied the log files cannot be recovered.

3.2.8 Import and Export Configurations

Import and Export features allow users to back up profile of PowerPanel Business Management and quickly deploy PowerPanel Business Management to multiple PC/Servers. When PowerPanel Business Management has been set up completed, users can use Export feature to output the profile of PowerPanel Business Management. The next time, when a new PC/Server would be set up with PowerPanel Business Management, users can upload the profile with the Import feature to complete PowerPanel Business Management setting immediately.

Notice: The profile of PowerPanel Business Management only can be applied in PowerPanel Business Management.

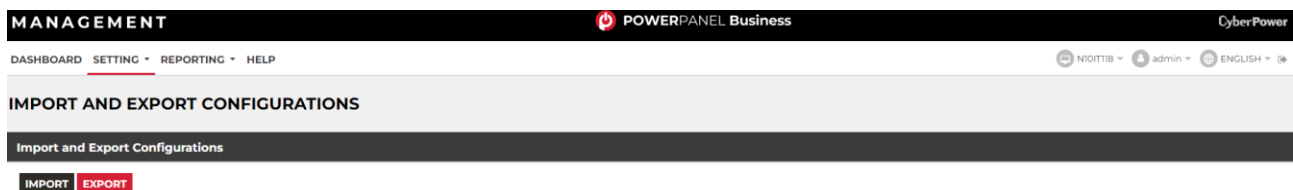

Import and export configurations

3.2.9 System Backup

Users are eligible to select **Scheduled Backup** or **Manual Backup**: backup frequency and path can be decided by user; those options are system-default in **Manual Backup**; data can only be restored to the same version of software. The function of system backup includes configuration, data and log; import/export only includes configuration. Other details of instructions will be provided in the software UI once license is activated.

Notice: This feature is license-needed. Free version of PowerPanel Management does not offer this feature.

3.3 REPORTING

3.3.1 System Logs

The **System Logs** page in Management provides users logs of recorded details from operations performed in Management. The logs can be used for analysis or to determine whether operations have been performed correctly.

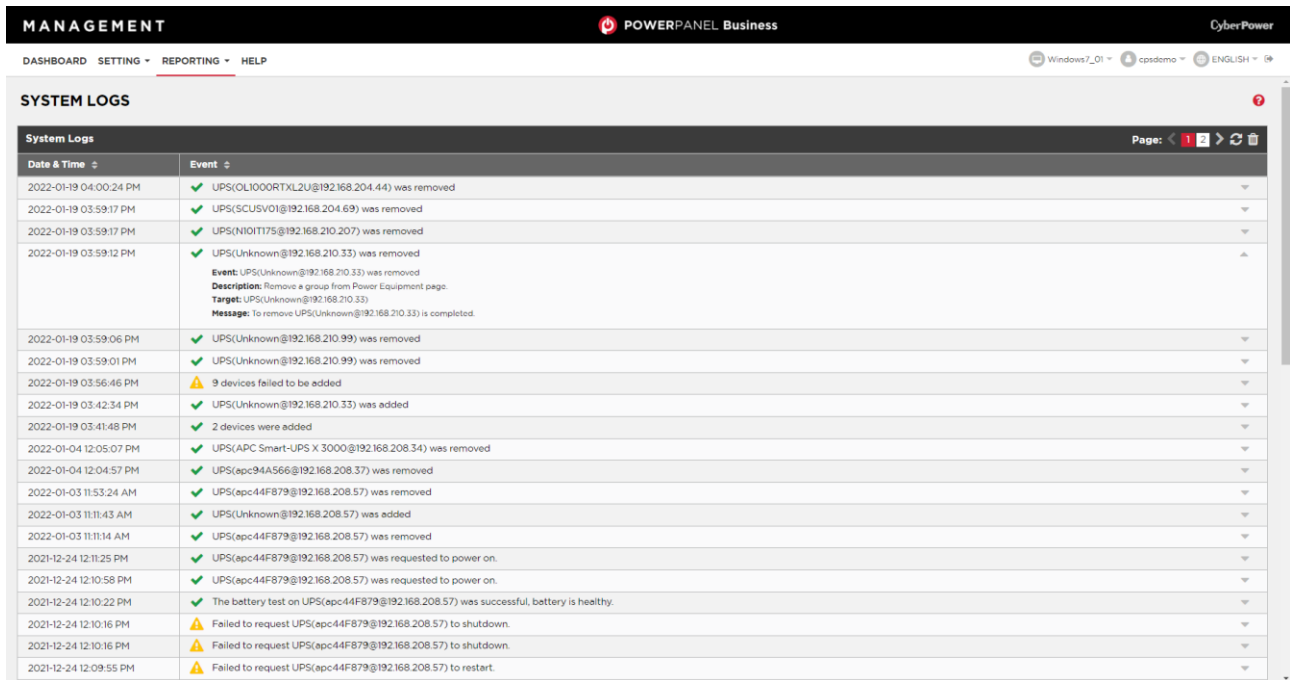

Date & Time	Event
2022-01-19 04:00:24 PM	UPS(OL1000RTXL2U@192.168.204.44) was removed
2022-01-19 03:59:17 PM	UPS(SCU5VD1@192.168.204.69) was removed
2022-01-19 03:59:17 PM	UPS(NIO1T175@192.168.210.207) was removed
2022-01-19 03:59:12 PM	UPS(Unknown@192.168.210.33) was removed Event: UPS(Unknown@192.168.210.33) was removed Description: Remove a group from Power Equipment page. Target: UPS(Unknown@192.168.210.33) Message: To remove UPS(Unknown@192.168.210.33) is completed.
2022-01-19 03:59:06 PM	UPS(Unknown@192.168.210.99) was removed
2022-01-19 03:59:01 PM	UPS(Unknown@192.168.210.99) was removed
2022-01-19 03:56:46 PM	9 devices failed to be added
2022-01-19 03:42:34 PM	UPS(Unknown@192.168.210.33) was added
2022-01-19 03:41:48 PM	2 devices were added
2022-01-04 12:05:07 PM	UPS(APC Smart-UPS X 3000@192.168.208.34) was removed
2022-01-04 12:04:57 PM	UPS(apc94A566@192.168.208.37) was removed
2022-01-03 11:53:24 AM	UPS(apc44F879@192.168.208.57) was removed
2022-01-03 11:11:43 AM	UPS(Unknown@192.168.208.57) was added
2022-01-03 11:11:14 AM	UPS(apc44F879@192.168.208.57) was removed
2021-12-24 12:11:25 PM	UPS(apc44F879@192.168.208.57) was requested to power on.
2021-12-24 12:10:58 PM	UPS(apc44F879@192.168.208.57) was requested to power on.
2021-12-24 12:10:22 PM	The battery test on UPS(apc44F879@192.168.208.57) was successful, battery is healthy.
2021-12-24 12:10:16 PM	Failed to request UPS(apc44F879@192.168.208.57) to shutdown.
2021-12-24 12:10:16 PM	Failed to request UPS(apc44F879@192.168.208.57) to shutdown.
2021-12-24 12:09:55 PM	Failed to request UPS(apc44F879@192.168.208.57) to restart.

System Logs page

Each log has details which can be viewed by clicking the icon next each log. Using the paging toolbar at the top of the log list allows users to view older logs by changing the page displayed; clicking the refresh icon updates the logs displayed in the list.

3.3.2 Event Logs

The **Event Logs** page records the event logs that can be analyzed whether the devices and the system are functioning well. Each log records what event occurred of the device.

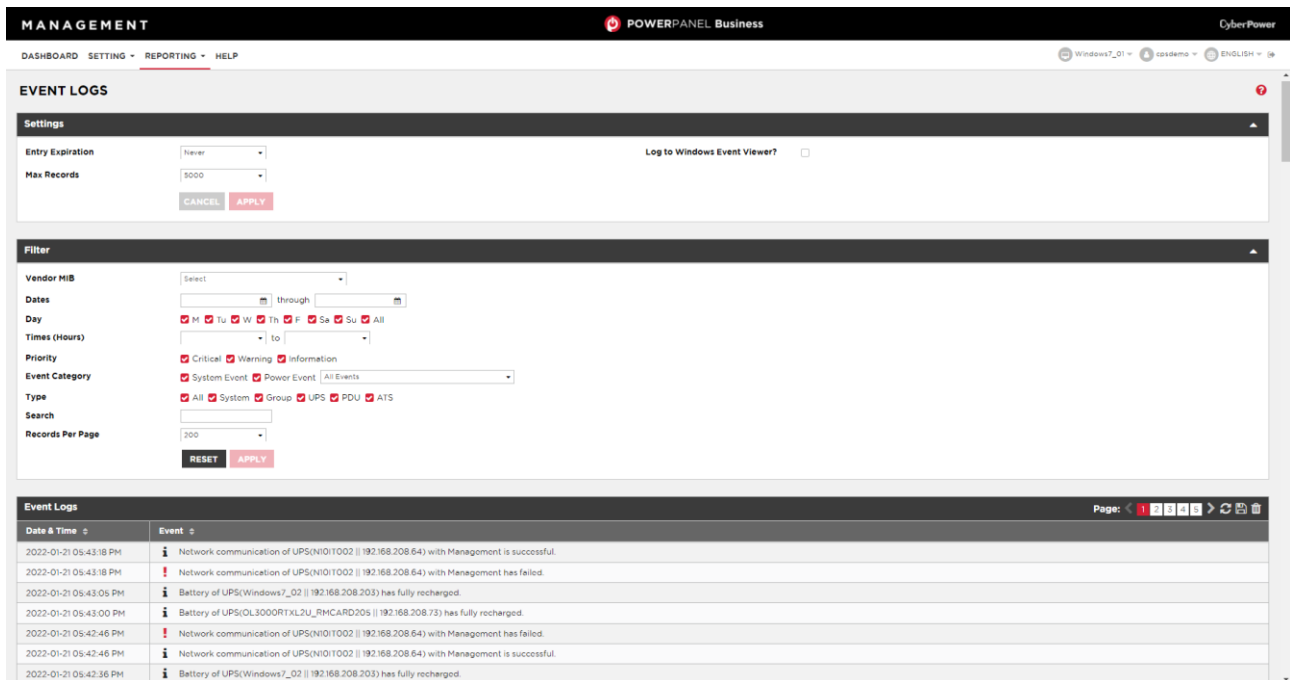

Event Logs page

3.3.2.1 Settings

(The contents in this section are only applicable to the administrator and super administrator.)

- **Entry Expiration:** This option specifies how long the log files will be retained.
- **Log to Windows Event Viewer:** Determines to log events to Event Viewer additionally. Users can launch the **Control Panel > Administration Tools > Event Viewer** to review all events in the **Application** category of the **Windows Logs** directory.

Note: Event Viewer is only function on the Windows platforms. If this option is not activated, you can activate this option by installing the PowerShell through Windows Update.

- **Max Records:** Indicates the maximum number of events that will be displayed.

3.3.2.2 Filter

After the configuration of the filter section is configured, click **APPLY** button to filter the logs.

- **Vendor MIB:** Select the Vendor MIB for the events to be displayed.
- **Dates:** Selects the Date for the events to be displayed.
- **Day:** Selects the Day(s) for the events to be displayed.
- **Times (Hours):** Selects the time range for the events.
- **Priority:** The events can be filtered by Priority.
- **Event Category:** The events can be filtered by category. The events can be further divided by **Power Event** and **System Event** categories, and choosing the specific event.
- **Type:** Select the Type of system, group, or devices to be displayed.
- **Search:** Enter the key words for the events to be displayed.

- **Records Per Page:** Specify the number of records to show per page.

3.3.2.3 Event Logs

Using the **Previous** and **Next** at the upper right corner of the event log list helps users to view the other range of filtered log result backward or forward. Clicking **Refresh**  will update the log result to display in the list according to the current filter options and paging settings.

Export

Click the **Save**  shortcut at the upper right corner of the event log table and select **CSV** or **PDF** file as the export file format. The exported file will be saved in the default download directory of your web browser.

Clear All Logs

(The function is only applicable to the administrator and super administrator.)

Click the **Delete**  shortcut at the upper right corner of the event log table, a confirm dialog will show up, all event logs will be removed immediately after clicking **DELETE**. The log clearing is permanent and once applied the log files cannot be recovered.

3.3.3 Energy Use

The **Energy Use** page shows a chart of how energy is spent in a specified period and also shows the energy statistics of the current target node and entire system.

3.3.3.1 Settings

(The contents in this section are only applicable to the administrator and super administrator.)

In this section, users can assign the rate of power consumption and carbon emission and set energy use alerts. When the rates are updated, the information presented in the Statistics page will also be updated.

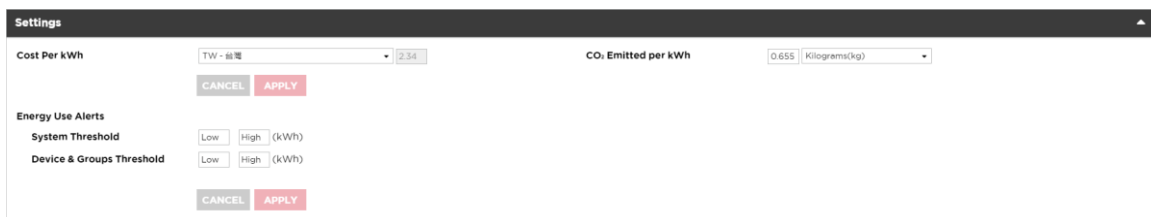

Energy Use/Settings

Management has the capability of reminding users of power consumption violations. The **Setting/Notifications/Notifications** page allows users to configure thresholds. When power consumption thresholds are violated, Management will notify the user.

- **Cost Per kWh:** Select the country the UPS is located in.

- **CO2 Emitted per kWh:** The weight of equivalent emitted carbon when one kWh power is consumed and the unit of measurement.
- **Energy Use Alerts**

Set the notifications thresholds for PowerPanel Business Management.

- **System Threshold.** When the power consumption of the entire system exceeds the high threshold or violates the low threshold, the event “**Power consumption is too high.**” or “**Power consumption is too high.**” of system will occur, respectively.
- **Device & Groups Threshold.** When the power consumption of the group or power equipment exceeds the high threshold or violates the low threshold, the event “**Power consumption is too high.**” or “**Power consumption is too high.**” of group or device will occur, respectively.

3.3.3.2 kWh Cost History

Because the rate of power consumption can vary over time, users can assign rates for different periods of time. Associated costs of historical periods will show in the table and user can edit or delete selected data. When rates are updated, the information displayed in the Metric section will also be updated.

kWh Cost History	
Date Range	Cost per kWh
2019-02-11 through 2019-02-13	\$0.13
2019-02-14 through Today	\$0.12

DELETE EDIT

Energy Use/kWh Cost History

3.3.3.3 Metrics

The **Statistics** page shows a chart of how energy is spent in a specified period of time and also shows the energy statistics of the current target node and entire system.

Also, for licensed users, updating firmware of Remote Management Card via PowerPanel Business Management is available from v4.12.

- Click **Connection** and finish account/password verification
- Choose **Type** if it is not automatically detected. Please refer to 
- Select device(s) and click **Firmware Update**
- Click **Apply** whenever you modify Type or switch to automatically update, or the configuration will not be valid

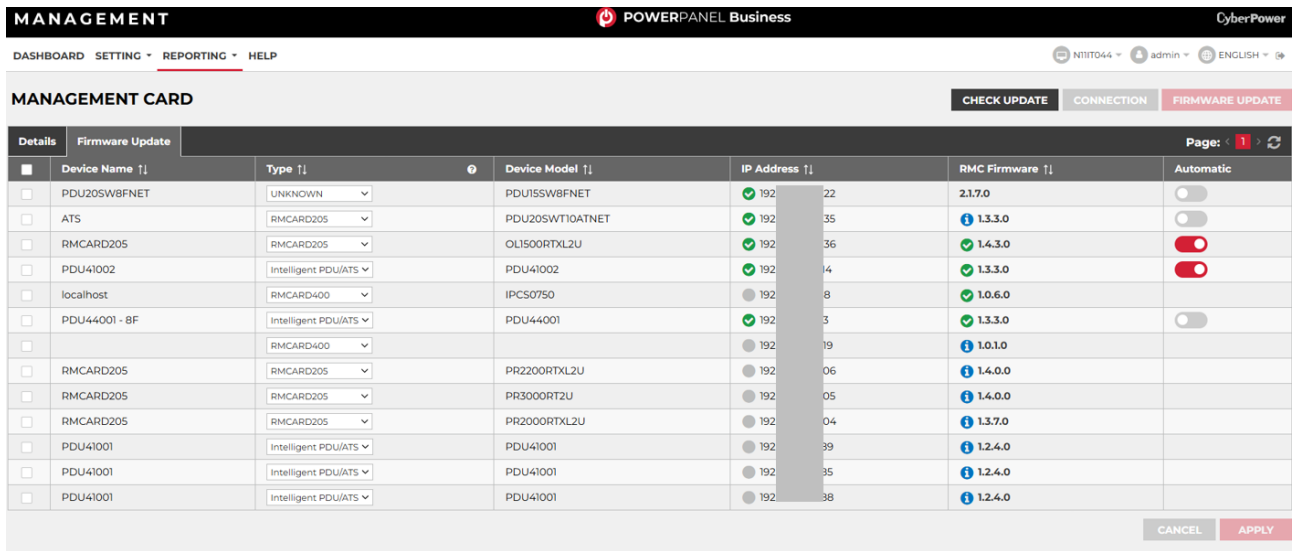

The screenshot shows the 'MANAGEMENT CARD' section of the PowerPanel Business interface. It features a table with columns for Device Name, Type, Device Model, IP Address, RMC Firmware, and Automatic. The table lists several devices, including PDU205W8FNET, ATS, RMCARD205, PDU41002, localhost, PDU44001 - 8F, and multiple instances of RMCARD205 and PDU41001. The RMC Firmware column shows various versions like 21.7.0, 1.3.3.0, 1.4.3.0, 1.3.3.0, 1.0.6.0, 1.3.3.0, 1.0.1.0, 1.4.0.0, 1.4.0.0, 1.3.7.0, 1.2.4.0, 1.2.4.0, and 1.2.4.0. The Automatic column has toggle switches for each device.

Details of updating history can be found in RMC Firmware:



The screenshot shows a 'Detail' window with a table of firmware update history for version 1.3.3.0. The table has columns for Last Action, Timestamp, and Result. Below the table is a 'Firmware Release Note' section for Version 1.3.3, which contains the text '0505 Stephen test 132->133'.

1.3.3.0		
Last Action ↑↓	Timestamp ↑↓	Result ↑↓
Firmware Update:1.3.3.0	2025-05-21 17:05:57	Success
Firmware Update:1.3.3.0	2025-05-12 10:45:27	Success
Firmware Update:1.3.3.0	2025-05-09 14:38:59	Success
Firmware Update:1.3.3.0	2025-05-05 14:41:04	Success

Firmware Release Note

Version 1.3.3

0505 Stephen test 132->133

3.4 HELP

3.4.1 PowerPanel Business

This section is an overview which includes the PowerPanel Business and host operating system. It also provides resources about contact website for assistances.

3.4.2 Check for Updates

The **Check for Updates** button is for users to check if there is a newer software version. There are three possible outcomes after clicking check for updates:



Check for updates button

- **New Software Version Detected:** A new software version is detected. Click **APPLY** button to upgrade the software version.

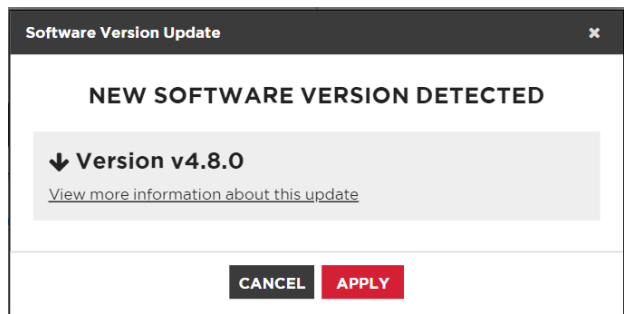

New software version detected

- **Software Is Up to Date:** Users' software is up to date.
- **Restoration:** Click **Restore to the previous software version** and then click **APPLY** if users want to restore the software to the previous software installed in the users' computer.

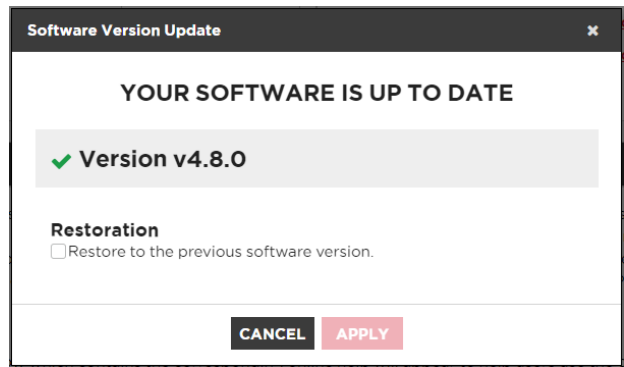

Users' software is up to date

3.4.3 Content

The **Content** page provides an overview which introduces the brief functions of what Local, Remote or Management do and indicates how to get related online-help content for current function page. It indicates a button to access to online-help directly.

3.4.4 Operation Log

The **Operation Log** button is for users to gather debug page for further confirmation.

- **Start:** Click **Start** to gather log.



- **Stop:** Click **Stop** to end the action of gathering log.



- **Export:** Click **Export** to get the log file for CyberPower service's further confirmation. The designated file will be automatically opened.



3.5 Web Browser Info

The top-right corner of PowerPanel Business Management user interface shows the installation location, account information and provides language selection.



Web browser info

3.5.1 PowerPanel Business Management Installation Location

The name and IP of the computer that is installed with the PowerPanel Business Management is displayed.

3.5.2 Account Information

The **Account Information** section is used to change the PowerPanel Business Management login account information, including account name and password.

Change Password	
Account Name	<input type="text" value="admin"/>
Current Password	<input type="password"/>
New Password	<input type="password"/>
Confirm New Password	<input type="password"/>
<input type="button" value="CANCEL"/> <input type="button" value="SAVE"/>	

Account Information

Change Account Name or Password

- Enter the password in the **Current Password** field.
- Enter a new account name in the **Account Name** field if you want to change account name. Account name must be alphanumeric (0-9, A-Z and a-z).
- If you want to change password, enter a new password in the **New Password** field and enter the new password again in the **Confirm Password** field to confirm.
- Click **SAVE** to complete the change.

3.5.3 Language

Choose the language in which PowerPanel Business Management is displayed.

4 Technical Support

4.1 Troubleshooting

1. I cannot access the PowerPanel Business web interface after complete installation.

Please follow the below steps resolve the problem:

- Make sure that there is no other application utilizing port 3052 (UDP/TCP) and port 53568 (TCP). Use a command prompt with the command “netstat -o” to obtain information about which ports are used by which programs.
- Ensure the **PowerPanel Business** service is running on the hosted computer. If the service is stopped, restart the service and then try again in the same way.
- Make sure the port 3052 (UDP/TCP) and port 53568 (TCP) on the hosted computer are not blocked by a firewall.
- Make sure the URL in the address filed of the browser for a remote computer is correct.

2. The PowerPanel Business installation failed.

If the installation file is from CyberPower web site, it may have downloaded incompletely or become corrupt. Download the installation file again.

3. I failed to extend the off-delay time of Necessary shutdown time option.

- The communities on the **SETTING/Security** page in the Remote and on the **Network/Access of Control** page in the PDU may be not matched. Confirm that the communities with the write permission are matched.
- The Remote may use the community without write permission to access the PDU. Please promote the permission of the community which is used by the Remote to access the PDU.

4. The shutdown occurs earlier than expected time.

It may be caused by the following conditions:

- When batteries have been used for a long time, they are unable to reach a full charge. Check to see if the output load is too high. A high load on the UPS will cause the batteries to discharge faster and the remaining runtime quickly decrease. Disconnect some load from the UPS to reduce the load in order to extend the runtime.
- Verify that the batteries are fully-charged. If the capacity is too low, please charge the batteries to full capacity.

5. Pages cannot be displayed after I set up another port number in the Security/Network page.

The port that was set up in the **SETTING/Security** page may be occupied by other applications or services. This indicates that the pages can't be accessed through the assigned port.

6. The host name and IP address at the Local's banner on the vSphere Management Assistant (vMA) of the VMware ESXi host displays Unknown.

Follow below steps to correct this condition:

- Run the command `'sudo vi /etc/hosts'` with root permission.
- Add the below snippet with the IP address and hostname.
`192.168.1.1 hostname`
Note: IP address and host name can be inquired using the commands `'ifconfig'` and `'hostname'`.
- Restart the service using the commands `'sudo service ppbed stop'` and `'sudo ppbed service start'`
- Login the page again. The host name and IP address will be correct.

7. I have downloaded the Linux installer from the website. The installer cannot be launched.

Before launching the PowerPanel Business installer, you must change its access permission on the installer. You must have executable permission on the PowerPanel Business installer; otherwise, the message **"Permission Denied"** will be displayed.

Run the below example command to change its permission of the 32-bit installer on 32-bit Linux platform.

```
sudo chmod u+x ppb-XXX-linux-x86.sh (XXX is the version number of PowerPanel Business.)
```

Run the below example command to change its permission of the 64-bit installer on 64-bit Linux platform.

```
sudo chmod u+x ppb-XXX-linux-x86_64.sh (XXX is the version number of PowerPanel Business.)
```

After the permission of the PowerPanel Business installer is changed, the installation procedure will be allowed to launch.

8. Inability to Shutdown NAS during Power Failure.

When using sshpass tool cannot shut the NAS down during power failure, the version of the sshpass tool may be 1.04.

The sshpass tool whose version is 1.04 will result in inability to shutdown NAS. You must check whether the version of the sshpass tool is 1.04. If the version is 1.04, you must change another version.

9. The PowerPanel Business installation file's digital signature is not valid.

It is caused because the operating system does not support the SHA-256 signature the installation file uses. Please follow the solutions below to resolve the problem for different versions of Windows:

- On Windows 8.1, Windows 8, Windows 7, Windows Server 2012 or Windows Server 2008 R2, please update the Windows via **Windows Update** to support SHA-256 signatures.
- On the version earlier than Windows 7 or Windows Server 2008 R2, please click **Allow** or **Run** when security warning dialog appeared after the installation file is opened.

4.2 FAQ

1. **If multiple computers are connected to a single UPS, how do I determine which computer to install the Local or the Remote on to ensure each computer can be shut down gracefully in event of power outage?**

The computer that is connected to the UPS with a serial or USB cable should install the Local, and the remaining ones should install the Remote.

2. **After the PowerPanel Business installation is complete, how do I access the web interface?**

On Windows, you can select the **Start > All programs > PowerPanel Business > PowerPanel Business Local** (or **PowerPanel Business Remote/ PowerPanel Business Management**) for local use. You can also enter the URL, **http://hosted_computer_IP_address:3052/management**, in the address field of the web browser from a remote computer.

On Linux, you only enter the URL, **http://localhost:3052/management**, the address field of the web browser from a remote computer for a local access. You can also enter the URL, **http://hosted_computer_IP_address:3052/management**, in the address field of the web browser from a remote computer.

3. **Which operation systems are supported by PowerPanel Business software? And which browser supports them?**

Refer to the [**Getting Started/Prerequisites**](#) for more details.

4. **How can I make PowerPanel Business run a program when a particular event has occurred?**

Create a .cmd file and save it into the **extcmd** folder of PowerPanel Business installation folder. Then write a command to run your own programs into this script file. Please refer to the **default.cmd** in the **extcmd** folder to write your own script.

5. **I am not sure what the IP address of the UPS/PDU/ATS is. How can I obtain the correct IP address?**

Use the **Power Device Network Utility 2** tool to help you to find the correct IP address of UPS/PDU/ATS. This device list will list the all CyberPower device's IP address on the local network.

6. How do I uninstall PowerPanel Business?

On Windows, go to **Start > Control Panel > Add or Remove Programs**. Click the **Change/Remove** button of **PowerPanel Business** to uninstall the program.

On Linux and VMware ESXi, only PowerPanel Business Remote can be installed. The default installation directory is **/usr/local/PPB** on the Linux platforms and **/opt/PPB** on VMware ESXi. Execute the **uninstall.sh** command in the installation directory to uninstall the program.

7. How can I get a notice when a power condition has cleared?

When a power condition is clear, it will broadcast a notification and also run the command file. A custom script can be created for events. The script can utilize the environment variable **EVENT_STAGE** to compare the key **OCCUR** to identify an event that has occurred or **FINISH** to identify an event that has cleared.

8. What network protocol is used in PowerPanel Business?

SNMP is used on communications between Remote, Management, PDU or UPS with remote management card. **HTTP** and **HTTPS** are used between the Local and the Remote.

9. What the network ports are used by PowerPanel Business?

Port 3052 (UDP/TCP), port 53568 (TCP), port 161(UDP), port 162 (UDP) and port 53566(UDP), so it is necessary to make sure above ports are open.

10. How do I ensure that the SNMP settings between the Remote and UPS/PDU/ATS are properly setup?

To receive the trap notification from the UPS/PDU/ATS all the time, follow steps to verify the SNMP settings:

- Open the **Network/Trap Notification** page on the UPS/PDU/ATS web and the **SETTING/Security** page on the Remote.
- Confirm that the IP address of the Remote can be found on the **Network/Trap Notification** page of the UPS/PDU/ATS web. If the IP address can be searched, skip the step 3.
- If the IP address of the Remote could not be found, click the **Trap Receiver** shortcut of the **Network/Trap Notification** page to enter the **Trap Configuration** page. Enter the required data to add a new trap receiver.
- If the IP address of the Remote could be found, verify the SNMP settings are matched.

11. How do I determine that if my computer is using hibernation or not?

If the operating system is Windows 7, Windows Server 2008, Windows 8, Windows 10, Windows Server 2012 or Windows Server 2016 please follow the below steps to enable the hibernation.

- Open the **Command Prompt** dialog box.
- Use the command **powercfg.exe -hibernate on** to enable the hibernation.

12. Which series does my UPS model belong to?

Check the UPS model and determine to which series your UPS belongs:

- If the model name conforms to the format of “OLxxxxRMXL”, “OLxxxx”, it belongs to *Smart App Online* series.
- If the model name conforms to the format of “PRxxxxLCDRM”, “PRxxxxLCDRT”, “PPxxxxSWRM” or “PPxxxxSW”, it belongs to *Smart App Sinewave* series.
- If the model name conforms to the format of “ORxxxxLCDRM” or “ORxxxxLCDRT”, it belongs to *Smart App Intelligent LCD* series.
- If the model name conforms to the format of “OPxxxx” or “CPSxxxxAVR”, it belongs to *Smart App AVR* series.
- If the model name conforms to the format of “OLxxxxTEXL” or “OLxxxxEXL-M”, it belongs to *Paragon Tower* series.
- If the model name conforms to the format of “PRxxxxELCDRT” or “PRxxxxELCDRTL”, it belongs to *Professional Rack Mount LCD* series.
- If the model name conforms to the format of “PRxxxxE”, it belongs to *Professional Rack Mount* series.
- If the model name conforms to the format of “PPxxxxE”, it belongs to *Professional Tower* series.
- If the model name conforms to the format of “ORxxxxELCD”, it belongs to *Office Rack Mount* series.
- If the model name conforms to the format of “OPxxxxE”, “OPxxxxTE”, “OPxxxxUE” and “OPxxxxUTE”, it belongs to *Office Tower* series.

13. How do I upload the installer to vMA?

- Login the **vSphere Client**.
- Select the VMware host.
- Click **Configuration**.
- Select the target datastore from the right-hand side.
- Right click the target datastore and click **Browse Datastore**.
- Click **Upload** button on the toolbar and select the file you want to upload.
- Click **OK** button to continue with the upload files into the target datastore.

14. How do I upgrade the virtual hardware version of vMA?

For vMA running on ESXi 5.x, it is recommended to upgrade the virtual hardware to version 8. To upgrade the virtual hardware version of VMA as below steps:

- Start the vSphere Remote and power off the target vMA.
- Right-click the virtual machine and select the **Upgrade Virtual Hardware** menu option to upgrade virtual hardware.

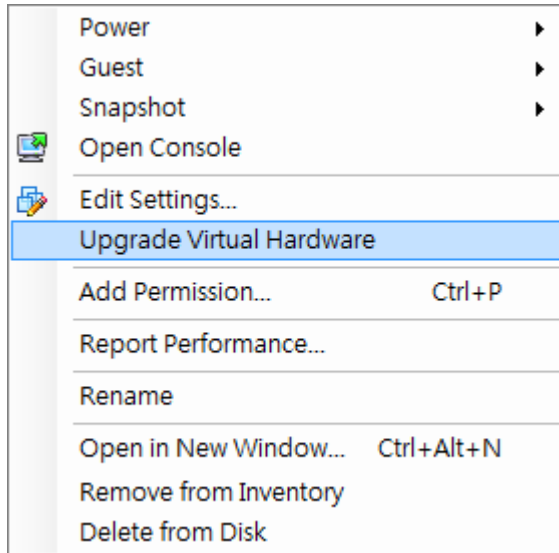

- Click **Yes** to continue with the vMA upgrade.

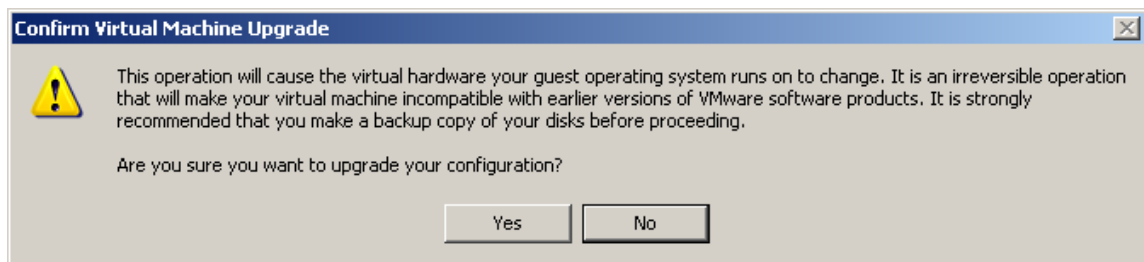

- Power on the vMA to make the changes take effect.

15. How do I restart the PowerPanel Business service?

For windows, restart the service from the **PowerPanel Business Service > Services > Administrative Tools > Control Panel**.

For Linux, run the commands in order to restart the service: `sudo service ppbed stop` and `sudo service ppbed start`.

16. I cannot add the new SSL certificate into the trust list.

Due the duplicate alias name is available in the trust list, the certificate cannot be added. In order to add the new certificate into the list, the certificate which has the duplicate alias name should be removed from the list. Follow the steps to remove the certificate:

- Switch to the `<Local_installation_directory>/jre/lib/security` directory in the command prompt.

```
cd <Local_installation_directory>/jre/lib/security
```

- Run the below command to remove the certificate from the trust list.
`<Local_installation_directory>/jre/bin/keytool.exe -delete -alias <alias_name> -keystore cacerts`
- Enter “changeit” as the password for the certificate removal.
- Enter “y” to apply the certificate removal.
- Restart the Local service to reload the trust list and take effect. Refer to **How to restart PowerPanel Business service** of **FAQ** chapter for more details.

17. I cannot successfully upload the profiles of PowerPanel Business Edition Center to PowerPanel Business Management.

Please compress the etc and extcmd folders in the PowerPanel Business Edition installation directory into a zip file as the file to be imported to the PowerPanel Business Management. PowerPanel Business Edition Center corresponds to PowerPanel Business Management.

18. How do I restore PowerPanel Business Local/Remote/Management to default setting?

- Right-click the tool bar and select Task Manager.

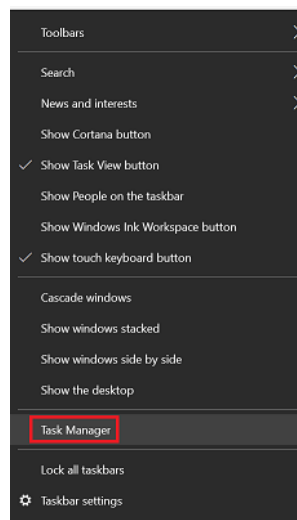

- Go to Services and find the programs “PowerPanel Business Services” and “ppbwd.”

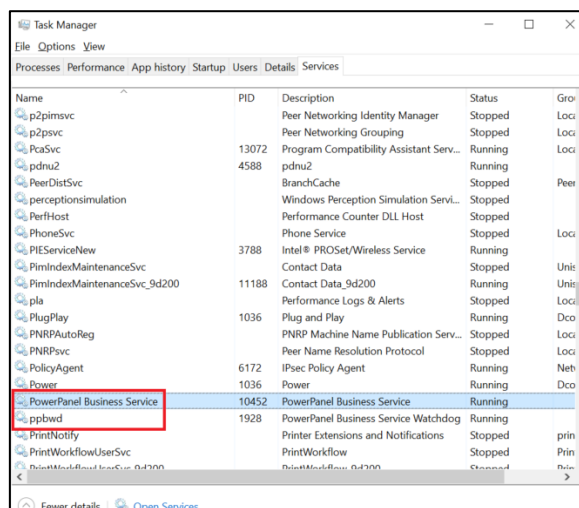

- Right-click “PowerPanel Business Services” and select Stop. Repeat the same procedure to stop the service of “ppbwd.”

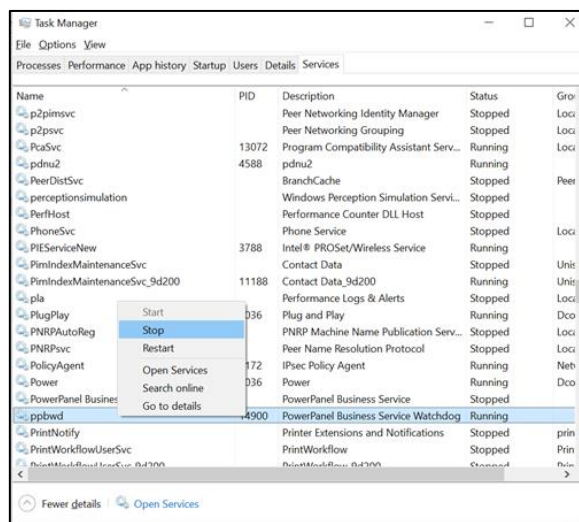
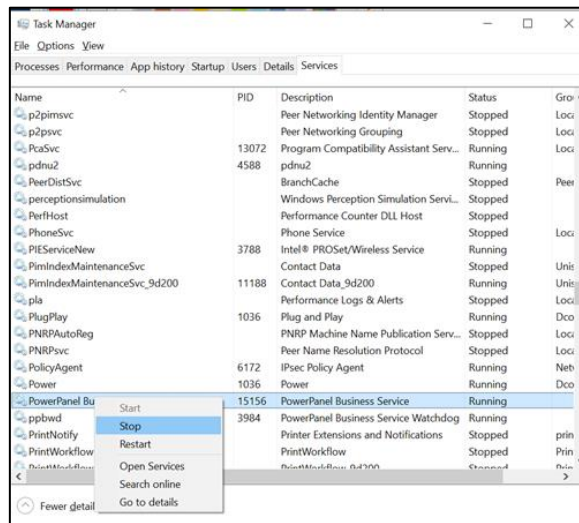

- Go to **C:\Program Files (x86)\CyberPower PowerPanel Business**, and delete **db_local** (or **db_remote** / **db_management**).

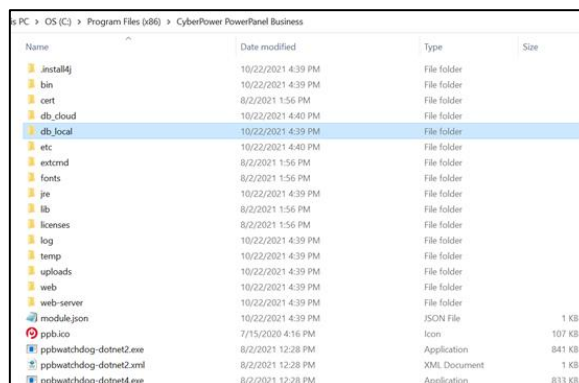

- Go back to Task Manager, right-click “PowerPanel Business Services” and select Start. Repeat the same procedure to start the service of “ppbwd.”

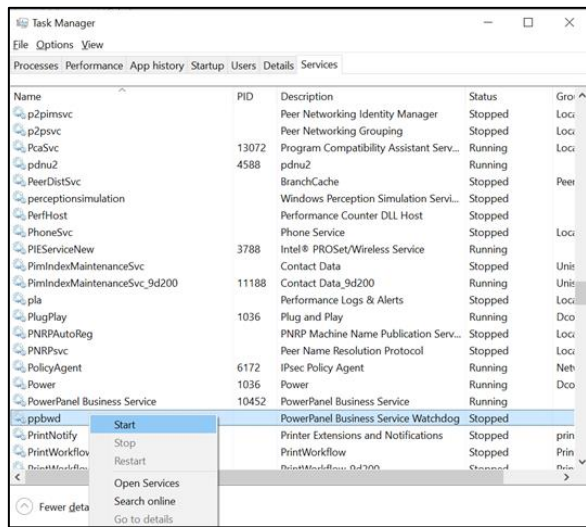
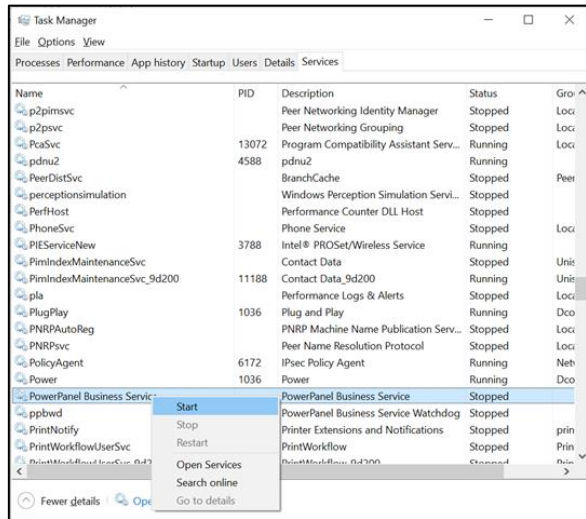

5 Glossary

- **Citrix XenServer:** A virtual-machine monitor allows several guest operating systems to execute on the same computer hardware concurrently. XenServer is supported by Citrix systems, Inc.
- **IP address:** An IP address is a series of numbers that identifies a particular computer or NIC on a network. IP is an abbreviation for Internet Protocol.
- **HTTPS:** Abbreviation for HTTP Secure. It provides encryption and secure identification of servers by using HTTP with SSL/TLS protocol. HTTPS connection is usually used for the sensitive transaction.
- **Power Device Network Utility:** Is an easy-to-use tool to setup network configurations of the UPS RMCARD/PDU/ATS. This includes setting the IP address, subnet mask, or gateway of UPS RMCARD/PDU/ATS.
- **PDU:** A PDU is a device which provides power output controls for individual outlets and connected equipment. PDU is an abbreviation for Power Distribution Unit.
- **SNMP:** The simple network management protocol. It is used by network management systems for monitoring network-attached devices for conditions that warrant administrative attention.
- **SSL:** Abbreviation for Secure Sockets Layer. SSL is a transaction security standard that provides data encryption, server authentication, and message integrity.
- **TCP/UDP:** Family of protocols for the transport and network layers.
- **TLS:** Abbreviation for Transport Layer Security. TLS is a cryptographic protocol which provides communication security over the internet. TLS and SSL provide data encryption and server authentication for message reliability.
- **vMA:** Abbreviation for vSphere Management Assistant. A virtual machine that includes prepackaged software and supported by the VMware, Inc. allows administrators to run scripts and Locals to manage ESXi hosts.
- **VMware ESXi:** An enterprise-level computer virtualization product offered by VMware, Inc. It is a component of VMware's larger offering, and adds management and reliability services to the core server products.
- **Virtual Appliance:** A virtual machine image is designed to run on a virtualization platform developed by VMware, Inc. It is intended to eliminate the installation, configuration and maintenance costs associated with running complex stacks of software.
- **VMware vCenter:** A vSphere's centralized tool that allows for the management of multiple ESXi servers and virtual machines from different ESXi servers through a single console application.
- **Microsoft Hyper-V Server:** A native hypervisor-based server virtualization product being offered by Microsoft Corporation.
- **ATS:** ATS is an electrical switch that switches a load between two sources. It can switch power automatically to a generator or other standby power source after a power outage. ATS is an abbreviation for Automatic Transfer Switch.

- **Environment Sensor:** A sensor accessory that can be installed on UPS/PDU/ATS for monitoring environment condition and obtaining information about the temperature and humidity.

CyberPower

Cyber Power Systems, Inc.

www.cyberpower.com

For USA and Canada:

4241 12th Ave East, Suite 400

Shakopee, MN 55379

Toll-free: (877) 297-6937

For all other regions:

Please visit our website for local contact information.

CyberPower and the CyberPower logo are trademarks of Cyber Power Systems, Inc., and/or affiliates, which are registered in many countries and regions. All other trademarks are the property of their respective owners.