

Adventure Starts Here.

37" SQUARE BAR TABLE

**SEAHAWK
DESIGNS**

EST. 2005

! NOTICE

- Do not overtighten hardware.
- Do not exceed the weight capacity of this item.
- Only use this item for what it is intended for, improper use will void any warranty.
- Firmly secure all bolts, screws and nuts before use.
- Reconfirm that all bolts, screws, and nuts are firmly secured every 90 days.
- Keep this furniture clear of all uncontrolled open flames or flammable/combustible materials. Exposure to fire, high heat, or embers will permanently damage the material.
- To avoid stripping and cracking of the material, DO NOT use power tools for assembly.
- Always prioritize caution and safety throughout the assembly process.

TOOLS REQUIRED



ALLEN WRENCH
(PROVIDED)

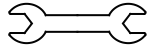

WRENCH
(PROVIDED)



220 LBS
WEIGHT
CAPACITY



SUGGESTED
2 PERSONS
ASSEMBLY



ESTIMATED
ASSEMBLY
TIME: 30 MIN

HARDWARE

REF#: OP7041

1

SCREW
M6 x 70mm



8 PCS

2

SCREW
M6 x 80mm



20 PCS

3

BOLT
M6 x 55mm

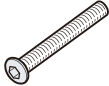

8 PCS

4

M6-NUT



8 PCS

5

M6-WASHER



8 PCS

6

SCREW HOLE PLUG



20 PCS

7

**UMBRELLA
EXTENSION POLE**

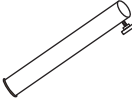

1 PC

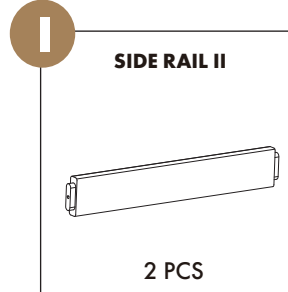
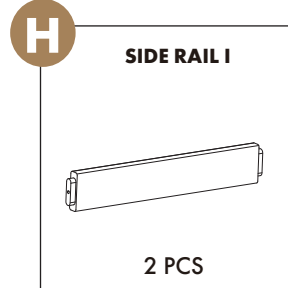
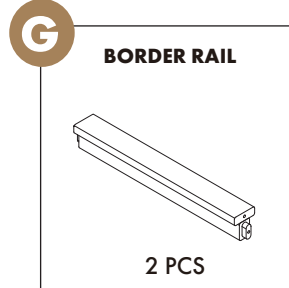
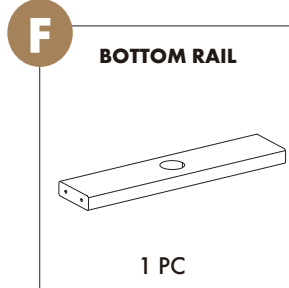
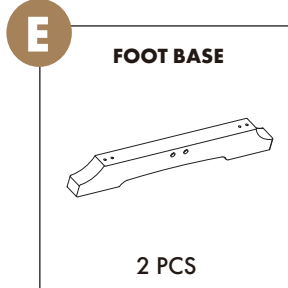
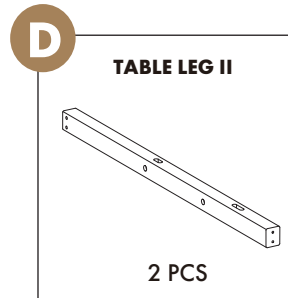
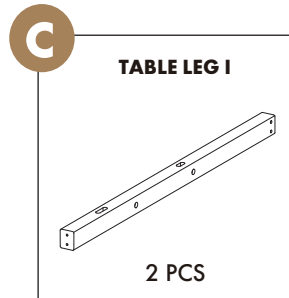
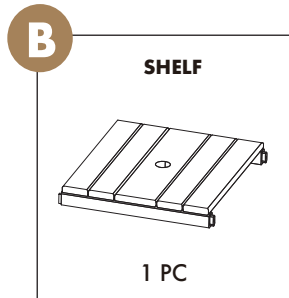
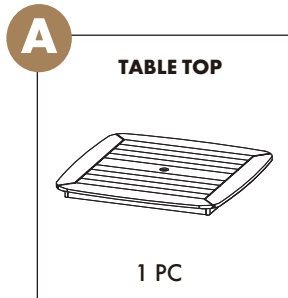

PRODUCT ASSEMBLY - OVERALL VIEW

REF#: OP7041

Please refer back to this image during the assembly process for part placement.

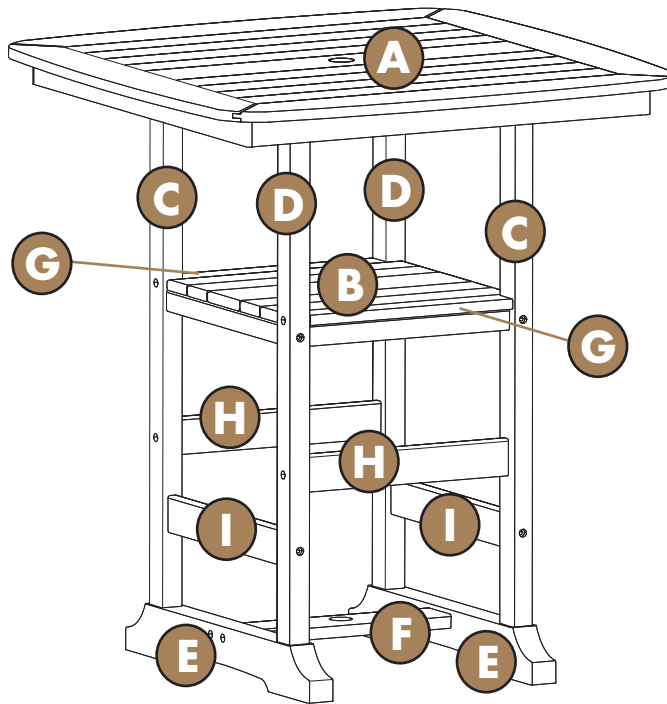

1

Step 1: Assemble the Rails and Table Legs

- Place **Table Legs (Part C and Part D)** on a flat, stable surface with the slots facing upward.
- Attach **Part G (Border Rail)** and **Part H (Side Rail I)** to **Table Legs (Part C and Part D)** using **4 - M6 Screw (#1)** (see image below).
- Do the same to attach another **Part G (Border Rail)** and **Part H (Side Rail I)** to **Table Legs (Part C and Part D)** (see image below).
- Do not fully tighten the bolts yet. Tighten them to approximately 70% to allow for adjustments during final assembly.

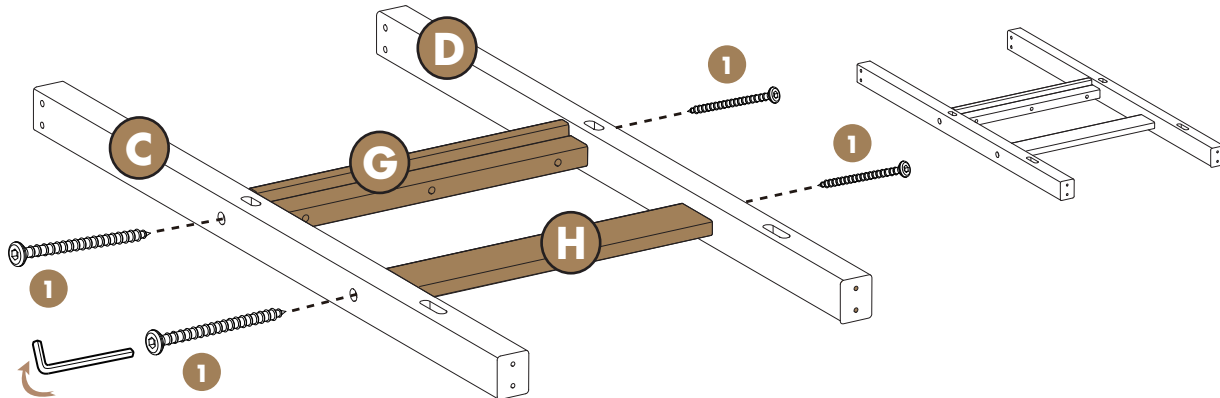

2

Step 2: Attach the Shelf and Side Rails

- Insert the ends on **Part B (Shelf)** and **2 - Part I (Side Rail II)** to the slots in **Part C** and **Part D (Table Legs)** (see image below).

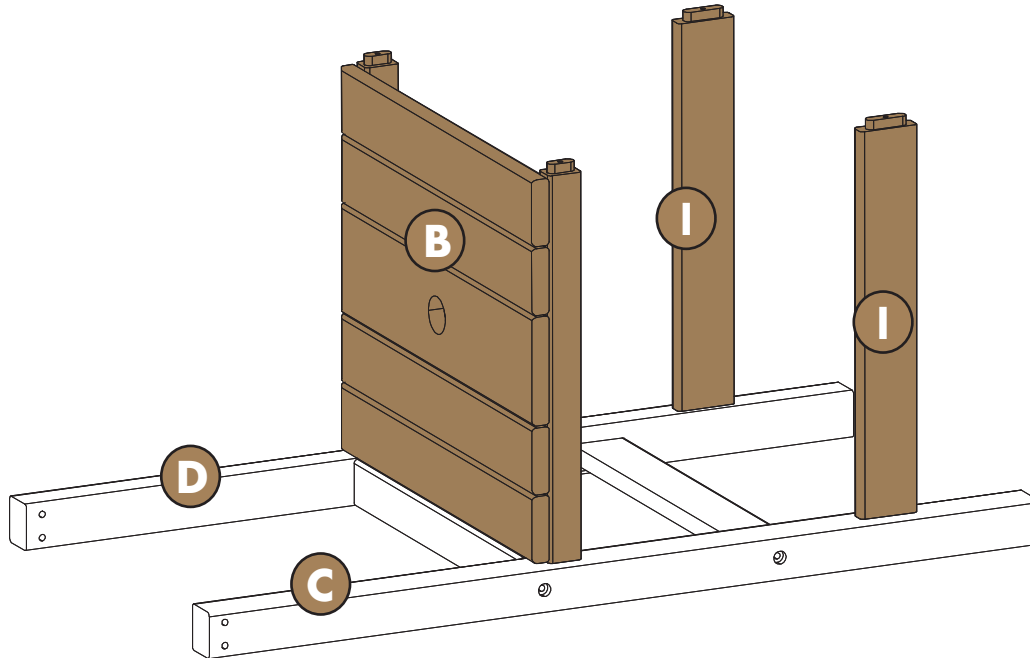

3

Step 3: Secure the Legs and Rails

- Attach **Assembled Legs (Part C, Part D, Part G and Part H)** to **Part B (Shelf)** and **2 - Part I (Side Rail II)** using **4 - M6 Screw (#2)** (see image below).
- Do the same to attach the pre-installed **Legs (Part C, Part D, Part G and Part H)** (Step 2).

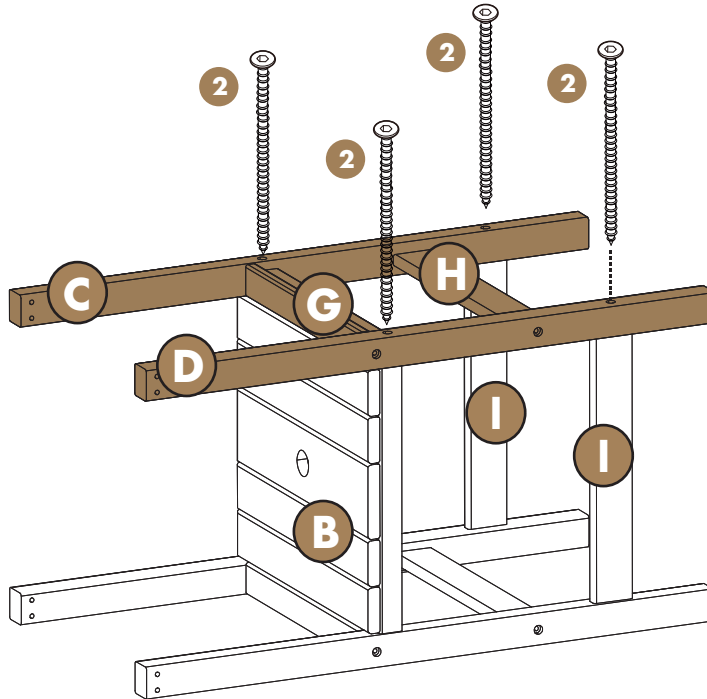

4

Step 4: Attach the Bottom Rail to the Foot Base

- Attach **Part F (Bottom Rail)** to **2 - Part E (Foot Base)** using **4 - M6 Screw (#2)** (see image below).

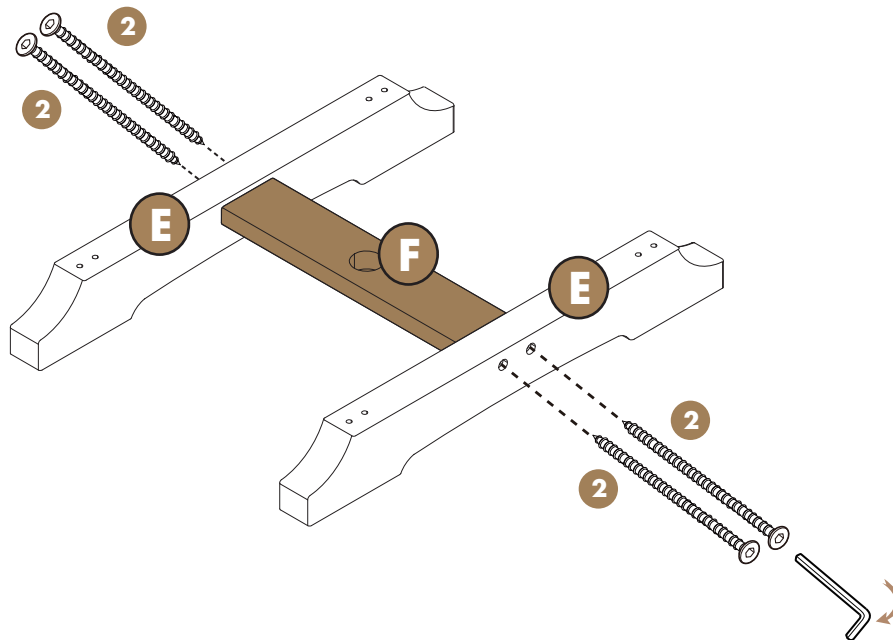

5

Step 5: Attach the Assembled Foot Base to the Assembled Frame

- Place the assembled frame upside down on flat surface and attach the **Foot Base (Part E, Part F and Part E)** to the **Assembled Legs (Part C and Part D)** using **8 - M6 Screw (#2)** (see image below).

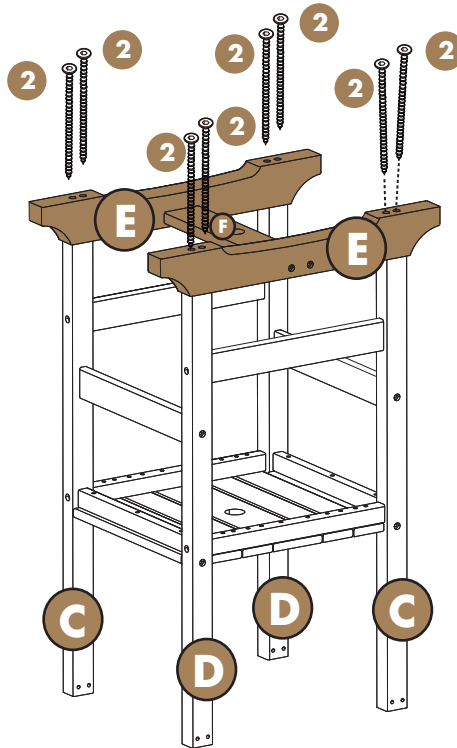

6

Step 6: Attach the Table Top to the Assembled Frame

- Place **Part A (Table Top)** upside down on flat surface and attach it to the assembled frame. This requires **8 - sets** of the **M6 Bolt (#3)**, **M6 Washer (#8)**, and **M6 Nut (#7)** (see image below).

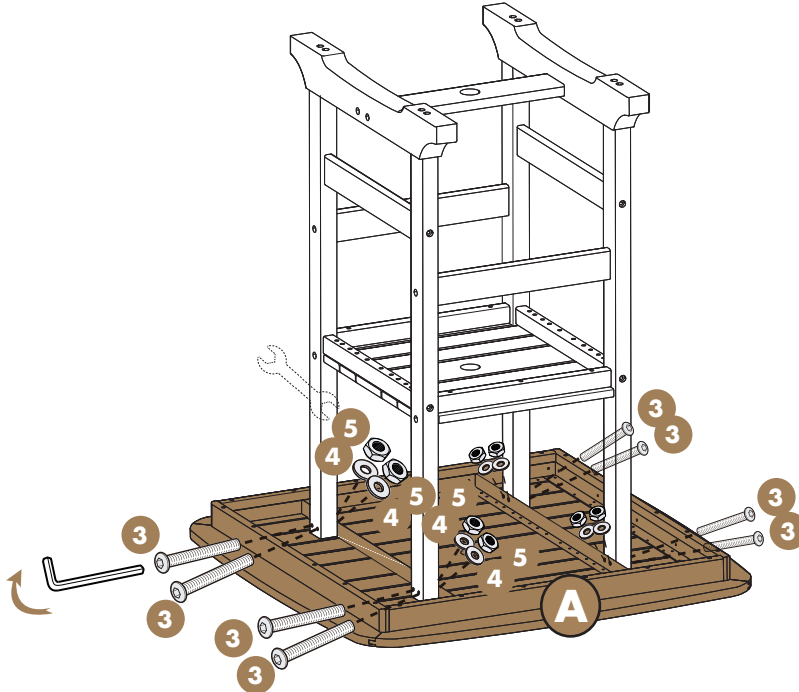

7

Step 7: Final Tightening and Stability Check

- Tighten all previously installed screws, bolts, and nuts. Check every connection to ensure the chair is steady and stable.



8

Tips: Extending the Height of your Umbrella

- Insert the **Umbrella Extension Pole (#7)** into the opening on the **Part F (Bottom Rail)** to increase your umbrella's height.

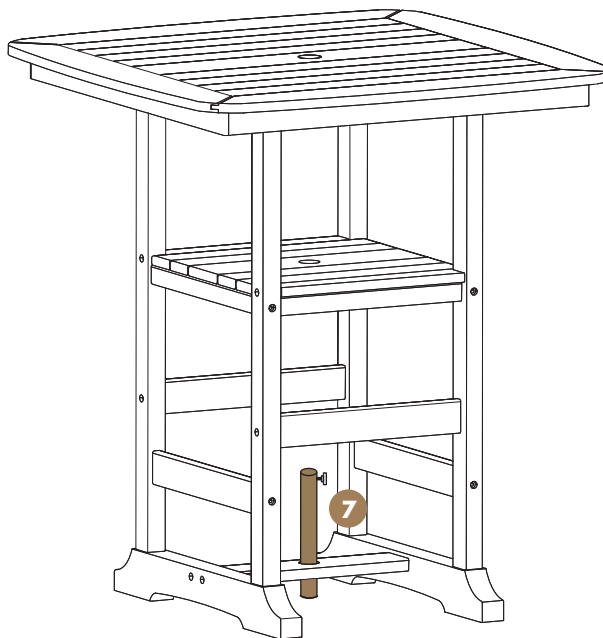

9

Step 8: Apply the Screw Hole Plugs

- Cover all exposed screw holes using **20 - Screw Hole Plug (#6)**. Insert all plugs into the exposed screw holes. Gently tap each plug into place using a rubber mallet to prevent damage. Ensure each plug is fully seated and flush with the table surface (see image below).

ATTENTION: Do not use a metal hammer as it will damage the poly lumber.

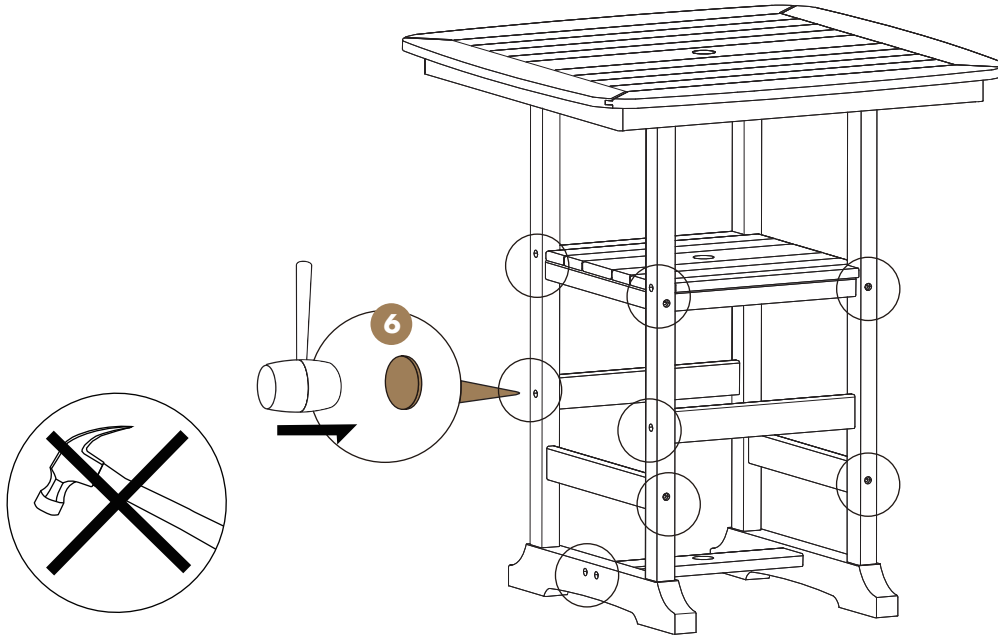

- **REGULAR CLEAN:** Mix **warm water** and **mild soap**. Use **a soft bristle brush** to gently scrub the surface and remove any dirt or stains.
- **QUICK CLEAN:** Simply wipe the furniture down using a damp cloth.

Tip: Cleaning your furniture regularly helps maintain its aesthetic appeal and extends its lifespan.

Enjoy!

Join our community and be the first to see what's new!

Follow us on socials:



Quickly register your outdoor furniture purchase to activate your warranty and enjoy peace of mind with guaranteed product protection:



Have questions or need assistance? Reach out to our dedicated team at **(909) 284-1052** or email us at **cs@seahawkdesigns.com**.