

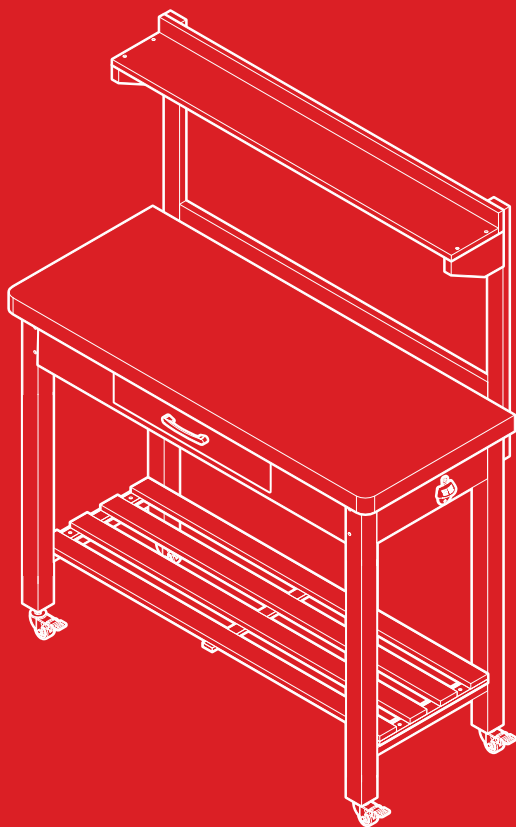

BEST CHOICE  
PRODUCTS



# INSTRUCTION MANUAL

---

Multipurpose Table  
/ Potting Bench

## ! NOTICE

Please retain these instructions for future reference.



2 PERSON  
ASSEMBLY



UP TO 60 MIN.  
ASSEMBLY

- Please do not exceed the weight limitations of this item.
- Do not stand on or use any part of this item as a step ladder.
- Firmly secure all bolts, screws and knobs before use.
- Reconfirm that all bolts, screws, and knobs are secure every 90 days.
- Fasten screws loosely during initial assembly. Do not firmly tighten the screws until the item is completely assembled.
- Do not use or store this item in the proximity of open flame or flammable/combustible chemicals.
- Be aware that some parts are heavy and have sharp edges.
- If any parts are missing, broken, damaged, or worn, stop using this product until repairs are made and/or factory replacement parts are installed.
- Do not use this item in a way inconsistent with the manufacturer's instructions as this could void the product warranty.

## TOOLS REQUIRED



PHILLIPS  
SCREWDRIVER



DRILL  
(OPTIONAL)



WRENCH  
(OPTIONAL)



RUBBER Mallet  
(RECOMMENDED)



200 LBS  
TABLETOP  
CAPACITY



15 LBS  
TOP SHELF  
CAPACITY



125 LBS  
BOTTOM SHELF  
CAPACITY

## HARDWARE

1

WHEEL



4 PCS

2

FOOT CAP



4 PCS

3

DRAWER  
HANDLE



1 PC

4

S-HOOK



6 PCS

5

J-HOOK



3 PCS

6

BOTTLE  
OPENER



1 PC

7

M3 x 30mm  
SCREW



2 PCS

8

M4 x 35mm  
SCREW



32 PCS

9

M4 x 30mm  
SCREW



4 PC

10

M4 x 25mm  
SCREW



10 PCS

11

M3 x 16mm  
SCREW



4 PCS

## PARTS

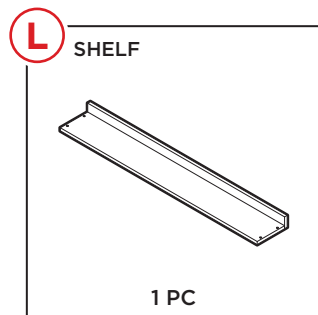
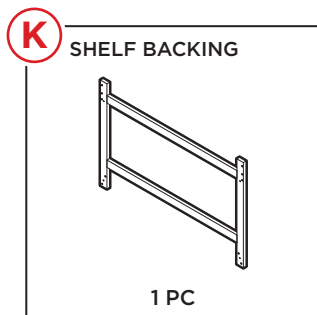
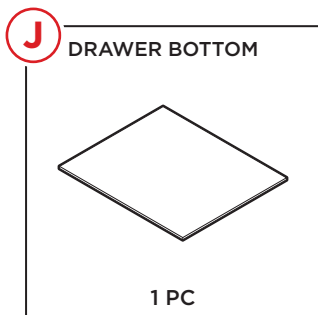
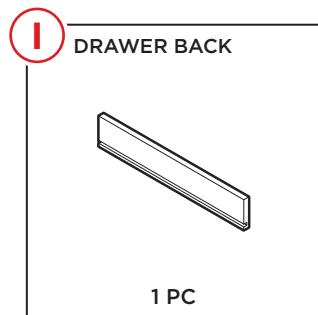
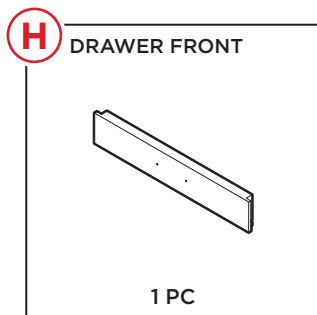
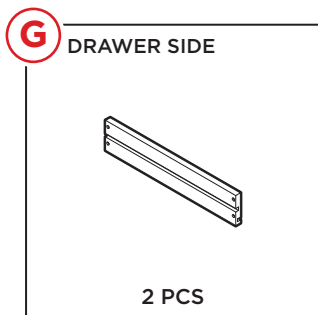
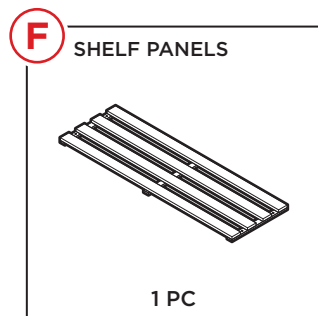
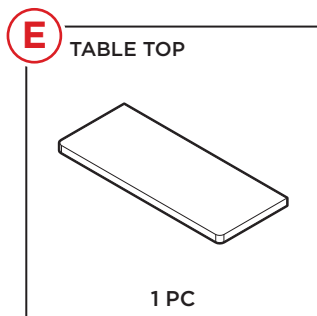
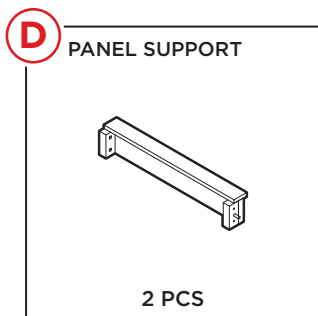
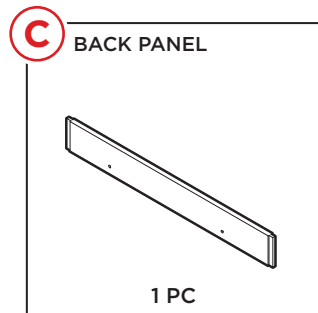
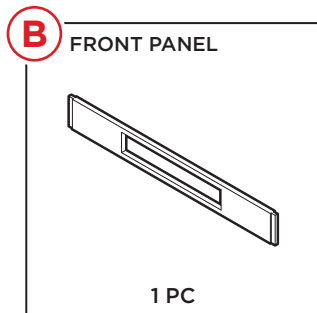
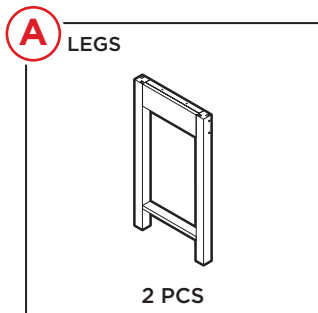

## PARTS

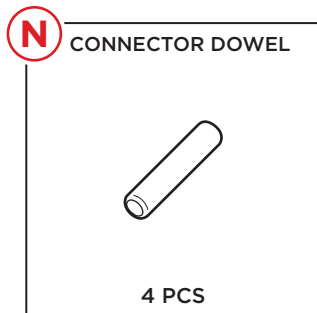
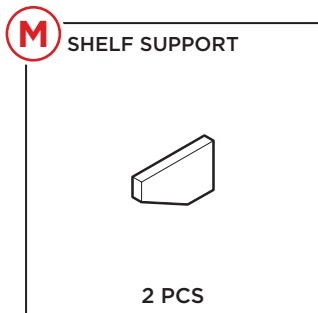

**NOTE:** This product contains multiple functional assemblies. The following steps are arranged to provide a successive assembly for each option.

## PRODUCT ASSEMBLY - TABLE/ISLAND

**1**

Attach two **part D** panel supports to the **part B** front panel and **part C** back panel with eight **part 8** screws.

**NOTE:** **Part B** has a set of large holes on its back face, these holes are intended for the above mentioned dowels. Make sure these holes face the drawer assembly.

Flip the assembly so the bottom and the horizontal planes of the panel supports face upward.

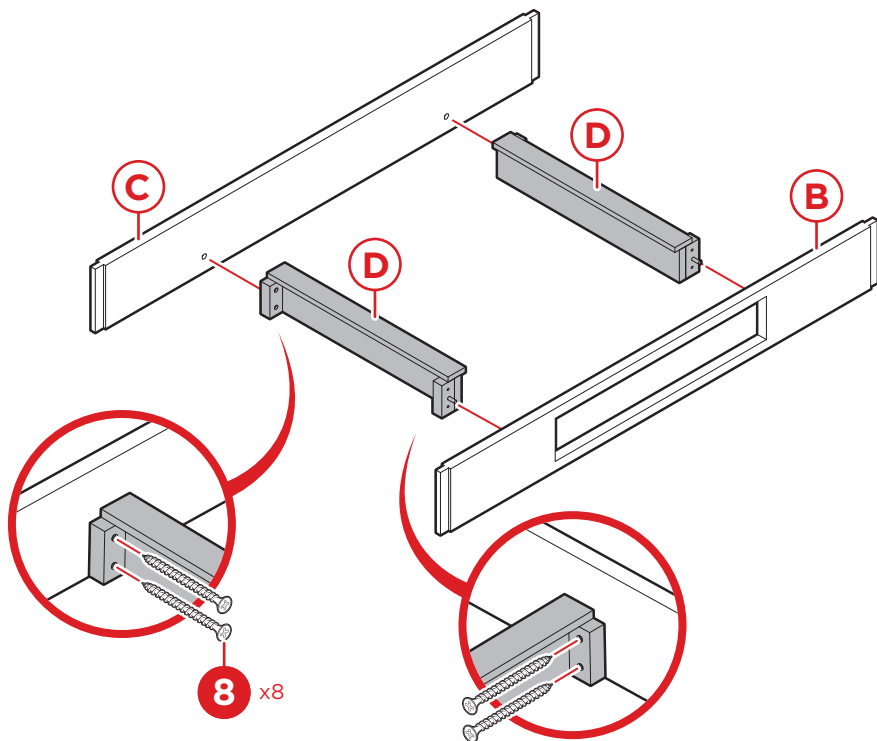

## PRODUCT ASSEMBLY - TABLE/ISLAND

2

Insert the panel assembly into the two **part A legs**, use a rubber mallet for proper alignment.

Secure the legs to the **part B & C panels** with eight **part 8 screws**, four screws per leg set.

**NOTE:** Complete this step as shown to prevent misalignment of parts and hardware.

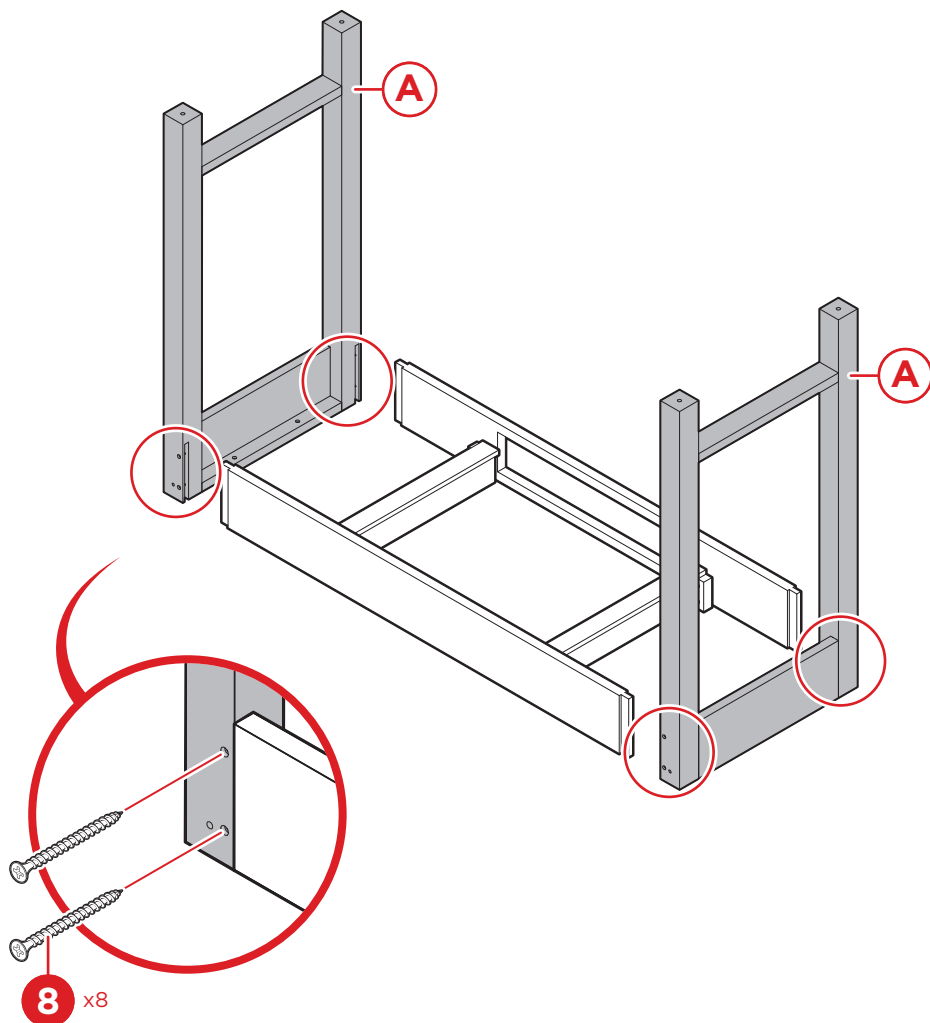

## PRODUCT ASSEMBLY - TABLE/ISLAND

3

Locate the **part J drawer bottom** and arrange the **part G, H, & I drawer panels** around the bottom panel as shown below to achieve proper alignment.

Use eight **part 10 screws** to connect the **part G side panels** to the **part I drawer back**, and **part H drawer front**.

Attach the **part 3 drawer handle** with two **part 7 screws**.

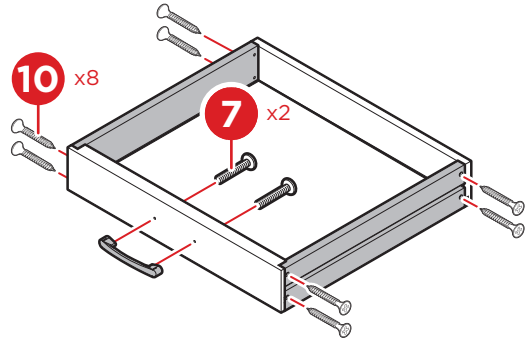
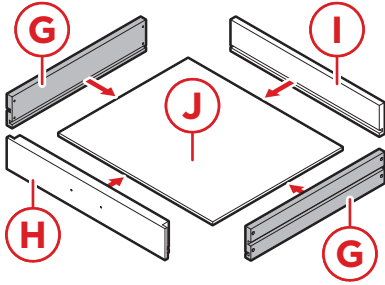

4

Insert the drawer assembly into the **part B front panel**.

Insert the **part 1 wheels** or the **part 2 leg caps** into the **part A legs**.

**NOTE:** Insert the drawer upside down so the **part J drawer bottom** faces upward.

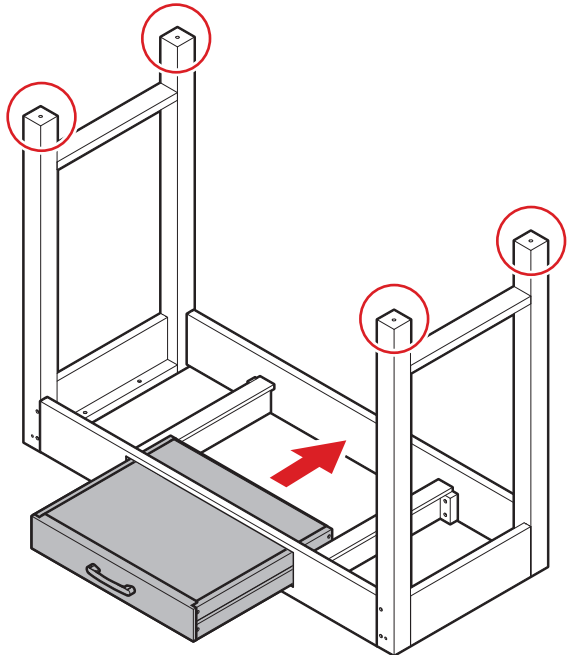
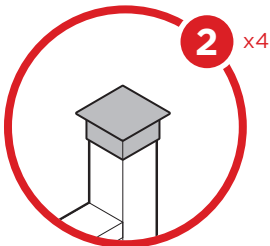
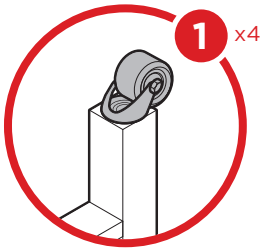

## PRODUCT ASSEMBLY - ISLAND

5

With the metal top facing down, place the **part E table top** onto a flat, protected surface to prevent damage. With a second person, flip the product assembly, center it on the table bottom, and place it onto the tabletop. Attach the **part E table top** with four **part 8 screws**.

**NOTE:** Make sure the back of the legs are square with the tabletop and the beveled edge is at the front.

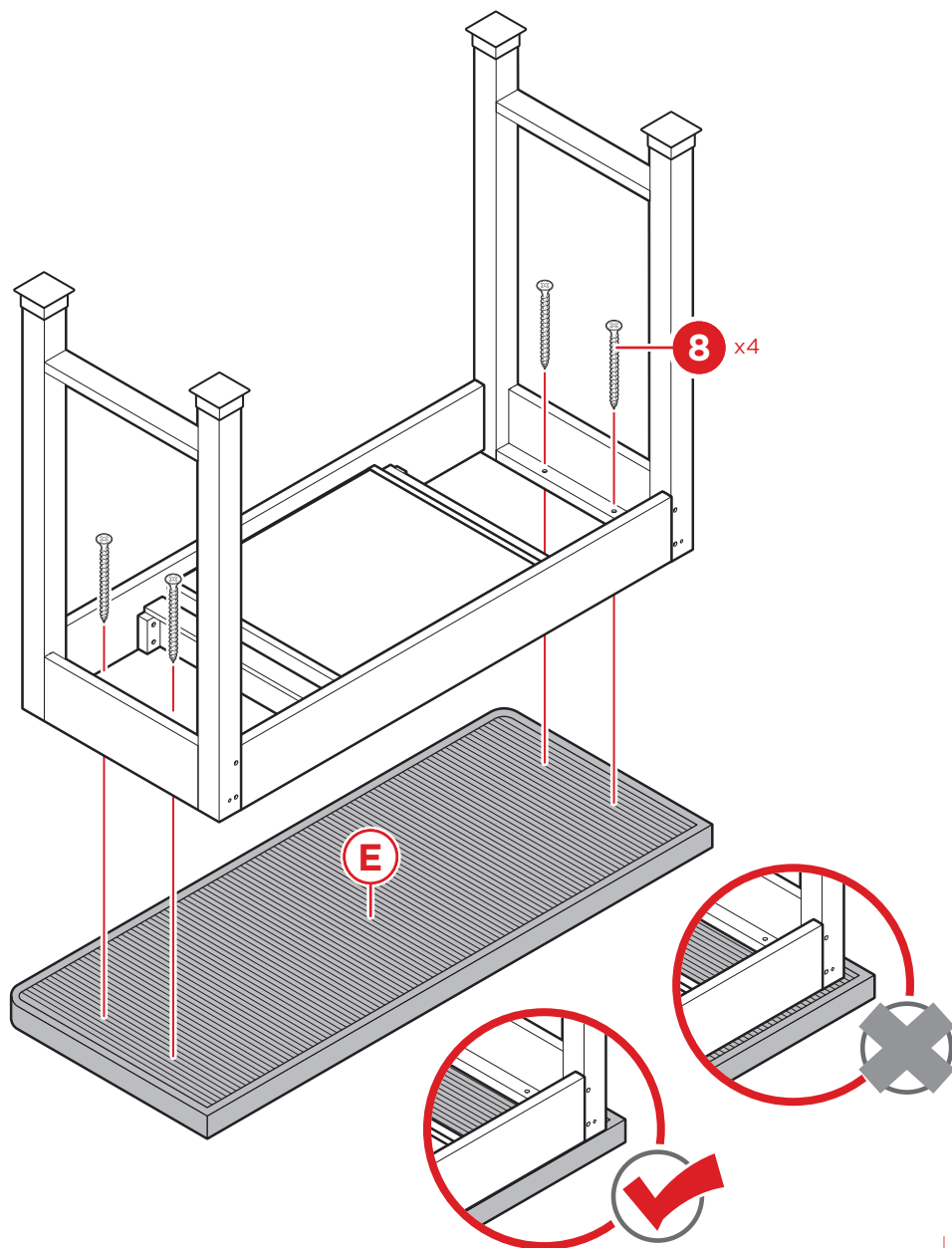

## PRODUCT ASSEMBLY - ISLAND

6

With a second person, flip the assembly upright, then attach the **part F shelf panels** to the **part A legs** with four **part 8 screws**.

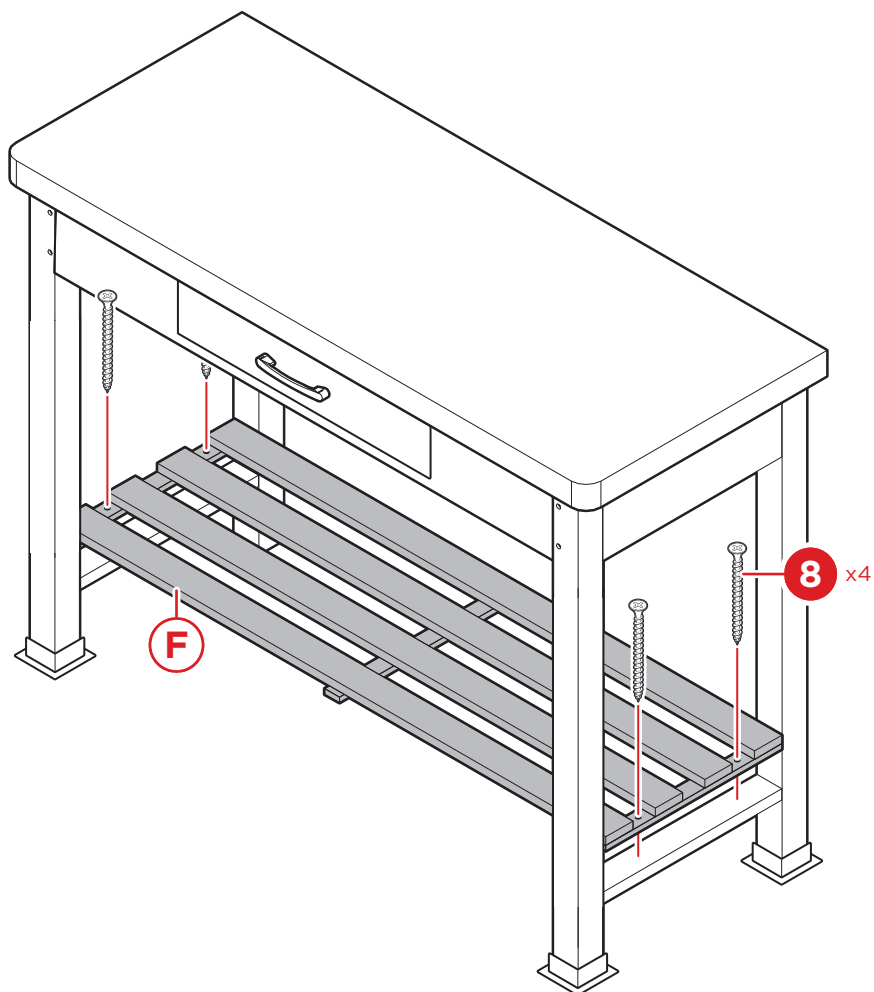

Table/Island is now assembled. To assemble **Potting Bench**, proceed to: **Product Assembly - Potting Bench**



## PRODUCT ASSEMBLY - POTTING BENCH

1

Follow steps 1-6 of **Product Assembly - Table/Island**.

Insert two **part N connector dowels** into the back of the **part A legs**.

Attach the **part K shelf backing** with four **part 8 screws**.

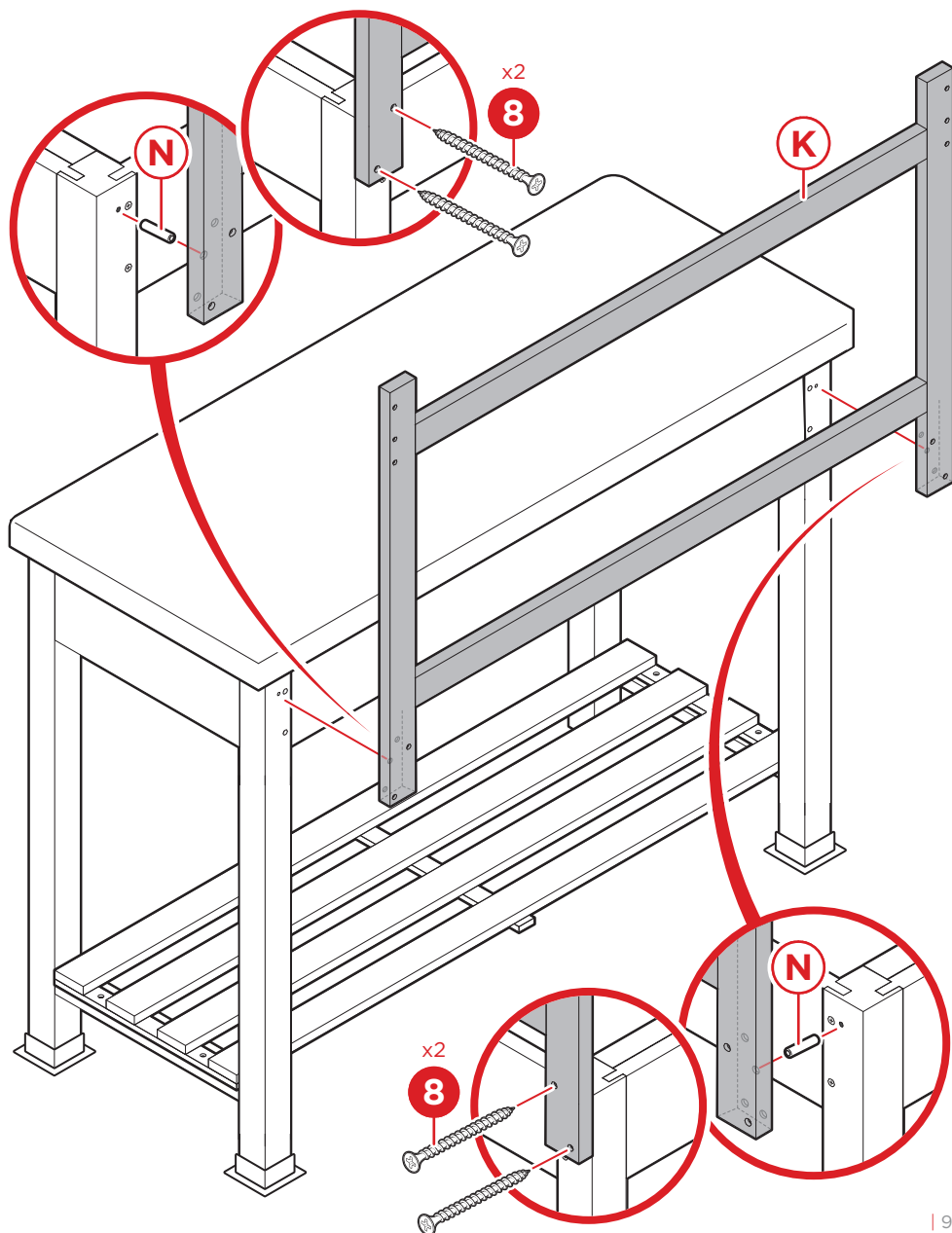

## PRODUCT ASSEMBLY - POTTING BENCH

2

Insert two **part N** connector dowels into the **part K** shelf backing, then attach the **part M** shelf supports with four **part 8** screws.

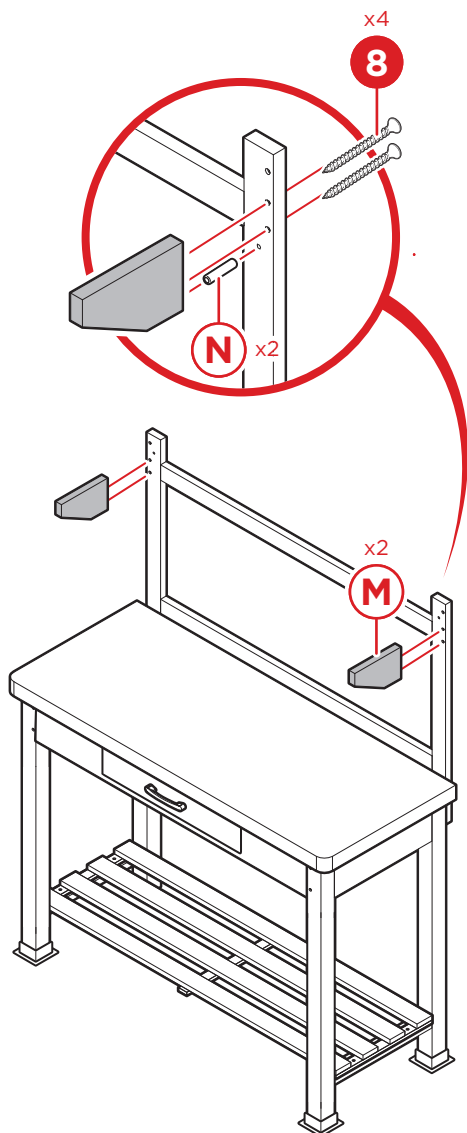

3

Attach the **part L** shelf to the **part M** shelf supports with four **part 9** screws, then attach the shelf to the **part K** shelf backing with two **part 10** screws.

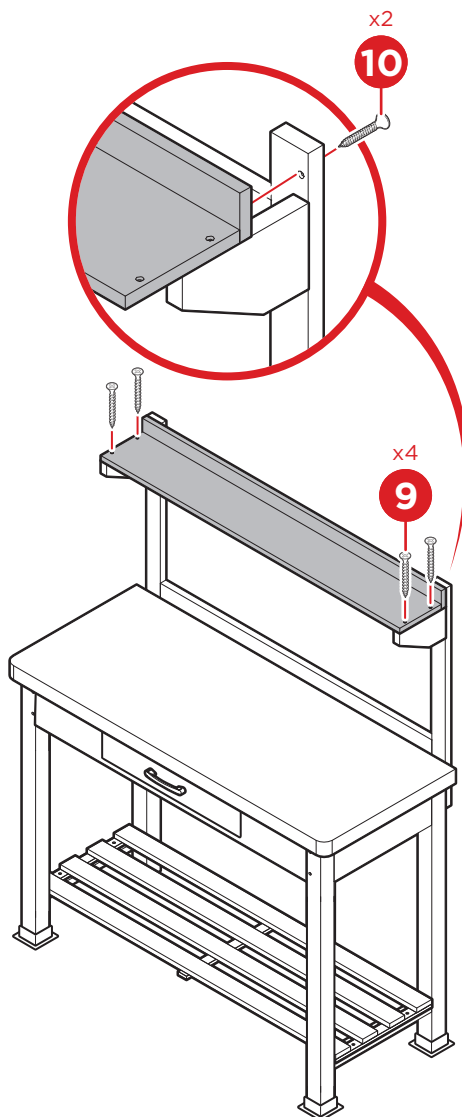

## PRODUCT ASSEMBLY - POTTING BENCH

4

**NOTE:** The following assembly steps are optional

Hang six **part 4 s-hooks** on the **part K shelf backing**.

Attach three **part 5 j-hooks** with three **part 11 screws**, then attach one **part 6 bottle opener**.

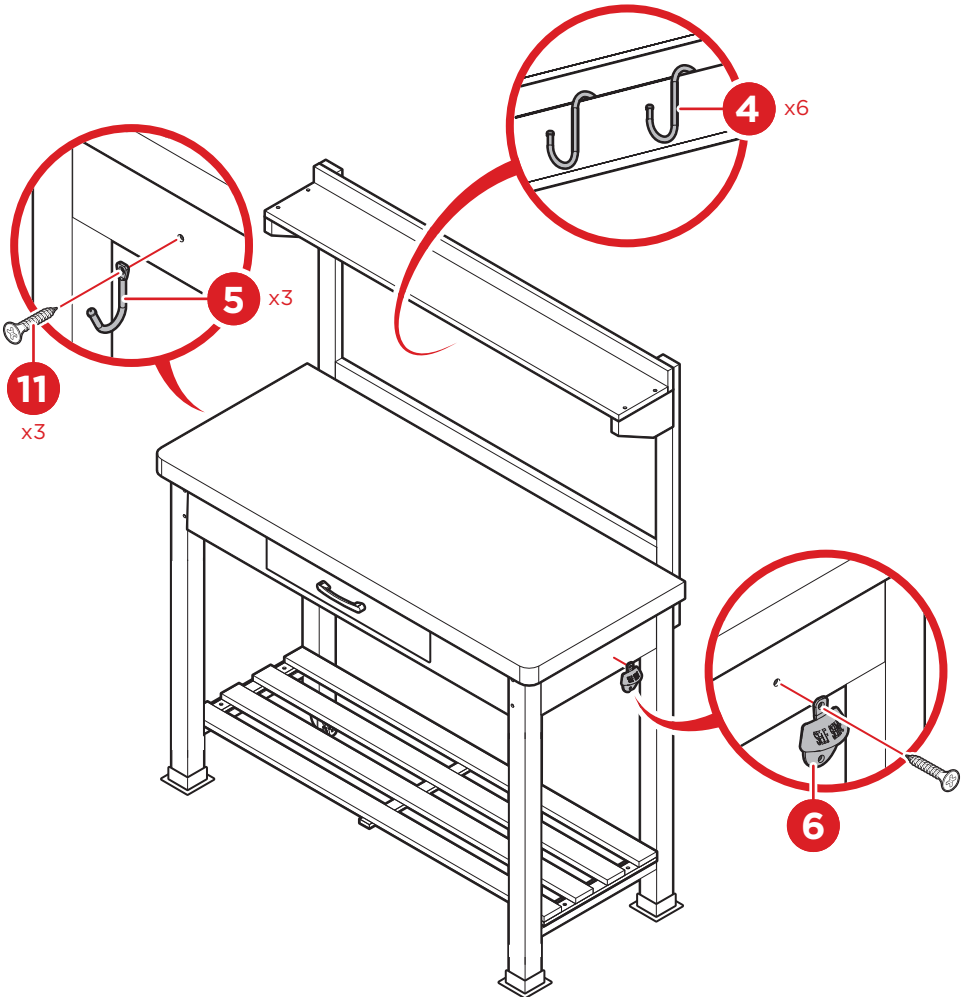

**NOTE:** To switch between the island and potting bench assembly, remove the **part K shelf backing** by unscrewing the **four part 8 screws** and **part N connector dowels**. To switch between the island and the table, remove the **part F shelf panels** by unscrewing the four **part 8 screws**.



# HELP CENTER



Question about your product? We're here to help. Visit us at:

[help.bestchoiceproducts.com](http://help.bestchoiceproducts.com)



Chat Support



Product Inquiry



Orders FAQ



Product Assembly



Returns & Refunds

## PRODUCT WARRANTY INFORMATION

All items can be returned for any reason within 60 days of the receipt and will receive a full refund as long as the item is returned in its original product packaging and all accessories from its original shipment are included. All returned items will receive a full refund back to the original payment method. All returned items will not be charged a re-stocking fee.

All returned items require an RA (Return Authorization) number, which can only be provided by a Best Choice Products Customer Service Representative when the return request is submitted. Items received without an RA may not be accepted or may increase your return processing time. Once an item has been received by Best Choice Products, refunds or replacements will be processed within 5 business days.

All returns must be shipped back to the Best Choice Products Return Center at the customer's expense. If the reason for return is a result of an error by Best Choice Products then Best Choice Products will provide a pre-paid shipping label via email. Boxes for return shipping will not be provided by Best Choice Products, and is the customer's responsibility to either use the original shipping boxes or purchase new boxes.

Pictures may be required for some returns to ensure an item is not damaged prior to its return. Items returned are not considered undamaged until they are received by Best Choice Products and verified as such. All damages to items are the customer's responsibility until the item has been received by and acknowledge by Best Choice Products as undamaged.



## WARNING

Manufacturer and seller expressly disclaim any and all liability for personal injury, property damage or loss, whether direct, indirect, or incidental, resulting from the incorrect attachment, improper use, inadequate maintenance, unapproved modification, or neglect of this product.