

Minicom has gained extensive experience in developing connectivity products to meet its customers' specific needs. This is the result of our constant commitment to R & D and the excellent quality of our products:

- A pure hardware solution
- Plug and play
- Highest video transmission standards
- Manufactured according to the latest quality standards

MINICOM
Advanced Systems Ltd.

WWW: <http://www.minicom.co.uk>

Supervisor MU

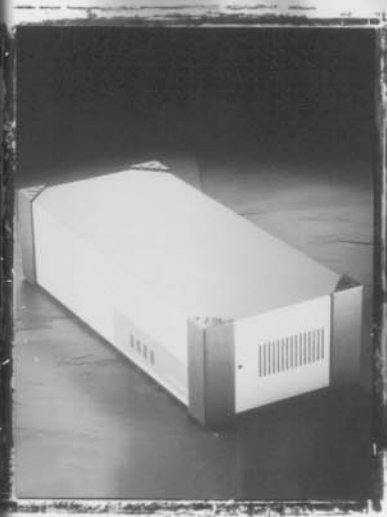

U
S
E
R
'
S
G
U
I
D
E



Despite 32 *different CPU Names*, there are only eight CPUs and the data is identical for a CPU. The only difference is in its *Name*. So, for example, the CPU that the User of KVM Workstation 1 describes as *Computer 4*, the User of KVM Workstation 2 describes as *Computer D*, the User of KVM Workstation 3 describes as *Info 4*, and the User of KVM Workstation 4 describes as *Telephones*.

The Supervisor MU supports:

- IBM PC/AT or PS/2 compatible machines
- 286, 386, 486, Pentium, Pentium II, or Silicon Graphics CPUs
- VGA, SVGA, or XGA video standards
- A mixed PC/AT and PS/2 environment, whose design requires no external adapter
- A Hot-Swap function letting you disconnect and reconnect CPUs without switching off the Supervisor MU

The Supervisor MU includes:

- A Programmable scan-mode operation with variable time interval
- An Autoskip function that automatically recognizes and indicates inactive CPUs
- Internal Switching Power Supply
- Reset Button
- Rack Mountable for standard 19" racks

How to use this Manual

This manual is divided into five sections:

Introduction and Overview (Chapters 1 and 2)

This section outlines the System.

Installation (Chapter 3)

This section focuses on connecting the hardware.

The Unit and OSD Set Up (Chapters 4 and 5)

This section describes the Supervisor MU Unit and summarizes OSD Set Up.

Operations (Chapter 6)

This section outlines the commands necessary for operating the OSD.

Appendixes and Index

This section contains reference material on technical specifications, and the System Product Line.

Table of Contents

<u>CHAPTER 1: INTRODUCTION</u>	1-1
<u>CHAPTER 2: OVERVIEW</u>	2-1
About OSD Technology	2-2
<u>CHAPTER 3: INSTALLATION</u>	3-1
Connecting the Supervisor MU	3-1
Connecting a CPU	3-2
To connect a PC/AT compatible CPU	3-2
To connect a PS/2 compatible CPU	3-4
Connecting a Remote KVM Workstation	3-6
To connect the PC/AT KVM Adapter Cable	3-6
To connect the PS/2 KVM Adapter Cable	3-8
Connecting the Power Supply	3-10
<u>CHAPTER 4: THE UNIT</u>	4-1
Supervisor MU Unit Front Panel	4-1
The Rear Panel Connections	4-2
<u>CHAPTER 5: OSD SET UP</u>	5-1
To invoke the OSD Window	5-1
Entering data in the OSD Window	5-1
To set up the OSD Window	5-2
To enter data in the OSD Window's upper part	5-2
To enter the data in the OSD Window's middle part	5-2
Entering data in the Timeout and Scan Window	5-5
To set up the Timeout and Scan	5-5
To replace data in the Timeout and Scan Window	5-7

<u>CHAPTER 6: OPERATIONS</u>	6-1
Using the OSD	6-1
To select a CPU	6-3
To control a CPU	6-3
To Close the OSD Window	6-4
To Reset the Mouse	6-4
To Scan the CPUs	6-4
To change the Hotkey from Shift to Control	6-5
To change the Keyboard Language	6-6
<u>APPENDIX A: TECHNICAL SPECIFICATIONS</u>	A-1
<u>APPENDIX B: PRODUCT LINE</u>	B-1
INDEX	I

The Supervisor MU is produced by Minicom Advanced Systems Limited and includes new features that are described later in this User's Guide, Version 898A.

Technical
precautions

This equipment generates radio frequency energy and if not installed in accordance with the manufacturer's instructions, may cause radio frequency interference.

This equipment complies with Part 15, Subpart J of the FCC rules for a Class A computing device. This equipment also complies with the Class A limits for radio noise emission from digital apparatus set out in the Radio Interference Regulation of the Canadian Department of Communications. These above rules are designed to provide reasonable protection against such interference when operating the equipment in a commercial environment. If operation of this equipment in a residential area causes radio frequency interference, the user, and not Minicom Advanced Systems Limited, will be responsible.

Changes or modifications made to this equipment not expressly approved by Minicom Advanced Systems Limited could void the user's authority to operate the equipment.

Minicom Advanced Systems Limited assumes no responsibility for any errors that appear in this document. Information in this document is subject to change without notice.

No part of this document may be reproduced or transmitted in any form or by any means, electronic or mechanical, for any purpose, without the express written permission of Minicom Advanced Systems Limited.

© 1998 Minicom Advanced Systems Limited. All rights reserved.

Trademarks

AT and PS/2 are registered trademarks of International Business Machines Corporation. All other trademarks and registered trademarks are the property of their respective owners.

Chapter 1: Introduction

The *Supervisor MU's OSD (On Screen Display)* technology superimposes a menu on the screen - the *OSD Window*, from which up to four Users can identify and select one of your eight CPUs.

However, only one User can work on a particular CPU at the same time - the other Users can view that CPU's screen but not work on it until it is free.

Each of the four Users sets his *OSD Window* independently of the other Users. Each of the four Users of KVM Workstations 1, 2, 3, and 4, respectively, can attribute separate *Names* to each of the eight CPUs, and specify different parameters for the *Timeout and Scan* of the eight CPUs.

A single *Supervisor MU* System can access up to eight *different* CPUs, where each of the four Users attribute different *Names* to the same eight CPUs, resulting in 32 *different CPU Names* as the following example illustrates:

1. The User of KVM Workstation 1 describes the eight CPUs as *Computer 1* to *Computer 8*.
2. The User of KVM Workstation 2 describes the eight CPUs as *Computer A* to *Computer H*.
3. The User of KVM Workstation 3 describes the eight CPUs as *Info 1* to *Info 8*.
4. The User of KVM Workstation 4 describes the eight CPUs as *Banking*, *Bills*, *Travel*, *Telephones*, *Purchasing*, *Printing*, *Personal*, and *Entertainment*.

Chapter 2: Overview

This chapter summarizes configuration of the Supervisor MU System. Each Supervisor MU System consists of one:

- KVM Cable for each of the four Users
- CPU Adapter Cable for each of the eight CPUs
- Supervisor MU Unit
- Power Cord

Figures 2-1 and 2-2, respectively, illustrate the front and rear panels of the Supervisor MU Unit.

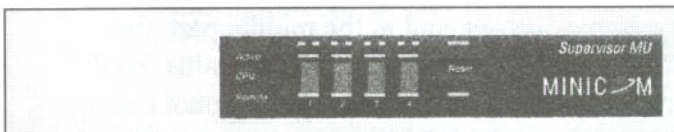

Figure 2-1: The Supervisor MU Unit Front Panel

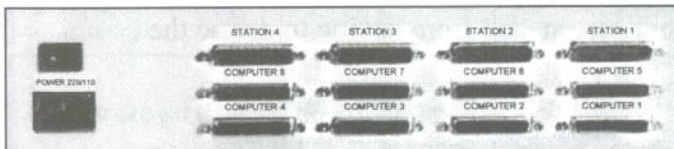

Figure 2-2: The Supervisor MU Unit Rear Panel

You operate the Supervisor MU System using the OSD. Each User can access and/or control one CPU at a time. The Supervisor MU System is easy to install and allows you to locate each KVM Workstation at up to 10m/33ft from the Supervisor MU Unit. You can place each CPU up to 6m/20ft from the Supervisor MU Unit.

Switch on the Supervisor MU Unit, and then the CPU. It is important to switch on the Supervisor MU Unit *before* switching on the CPU. For detailed operating instructions, refer to Chapter 6.

About OSD Technology

The OSD superimposes a menu on the screen from which you select one of the eight CPUs. After switching off the computer, the whole screen including the OSD Window becomes dark.

The OSD Window consists of three parts as Figure 2-3 illustrates - the upper, the middle, and the lower. You can change the information in the upper part, the *Name Section*, and in the middle part, the *Stations Section*. The lower part contains fixed preset operating instructions. You cannot change them. Automatic default settings save you wasting time choosing where to place the OSD Window on your screen, and from having to define the colors.

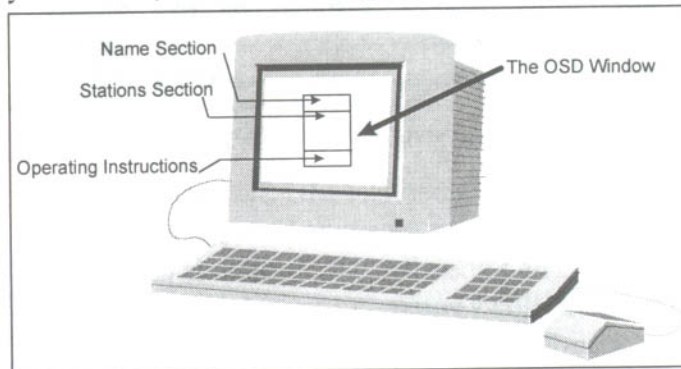

Figure 2-3: OSD Window

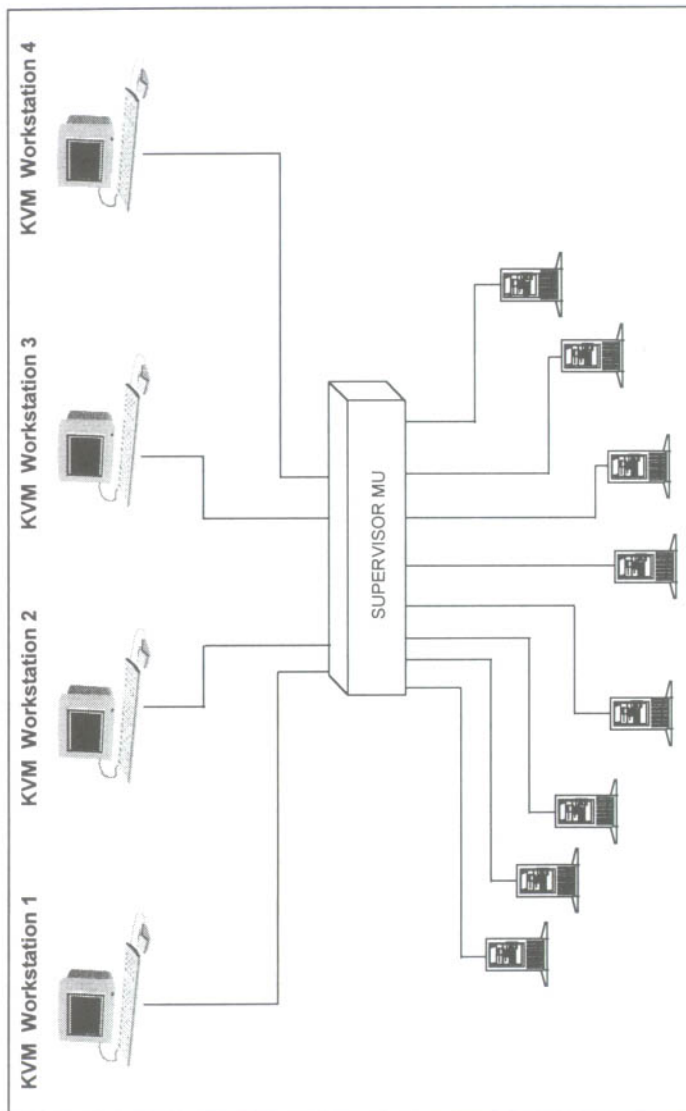

Figure 2-4: Block Diagram of the Supervisor MU

Chapter 3: Installation

Prior to installation observe these recommendations:

- *Place cables away from fluorescent lights, air conditioners, and machines that are likely to generate electrical noise.*
- *Switch off all CPUs and the Supervisor MU Unit.*

After installation you should observe the following recommendations:

- *Switch on the Supervisor MU Unit **before** switching on the CPU.*
- *Always switch on CPU # 1 otherwise your screen will appear dark and you will not see the OSD.*

Connecting the Supervisor MU

You may connect up to four Remote KVM Workstations and up to eight CPUs to the Supervisor MU Unit. The Supervisor MU Unit is compatible with PC/AT, PS/2, or a mixed environment - as Figure 3-11 on page 3-16 illustrates. Installing Supervisor MU involves connecting:

- Each CPU to the Supervisor MU Unit via a CPU Adapter Cable for PC/AT or PS/2.
- Each Remote KVM Workstation to the Supervisor MU Unit via a KVM Adapter Cable for PC/AT or PS/2.
- The System to the Power.

Connecting a CPU

You connect up to eight CPUs to the Supervisor MU Unit. You can mix one or more PC/AT and PS/2 type CPUs as part of the same Supervisor MU System - as Figure 3-11 on page 3-16 illustrates.

To connect a PC/AT compatible CPU

To connect each CPU to the Supervisor MU Unit, as Figure 3-1 illustrates, use a CPU Adapter Cable PC/AT as follows:

1. Connect the Adapter Cable's DB25M computer connector to the Computer # port on the Supervisor MU Unit's rear panel.
2. Connect the DIN5M keyboard connector to the keyboard port on the CPU's rear panel.
3. Connect the HDD15M screen connector to the screen port on the CPU's rear panel.
4. Connect the DB9F mouse connector to the serial mouse port on the CPU's rear panel.

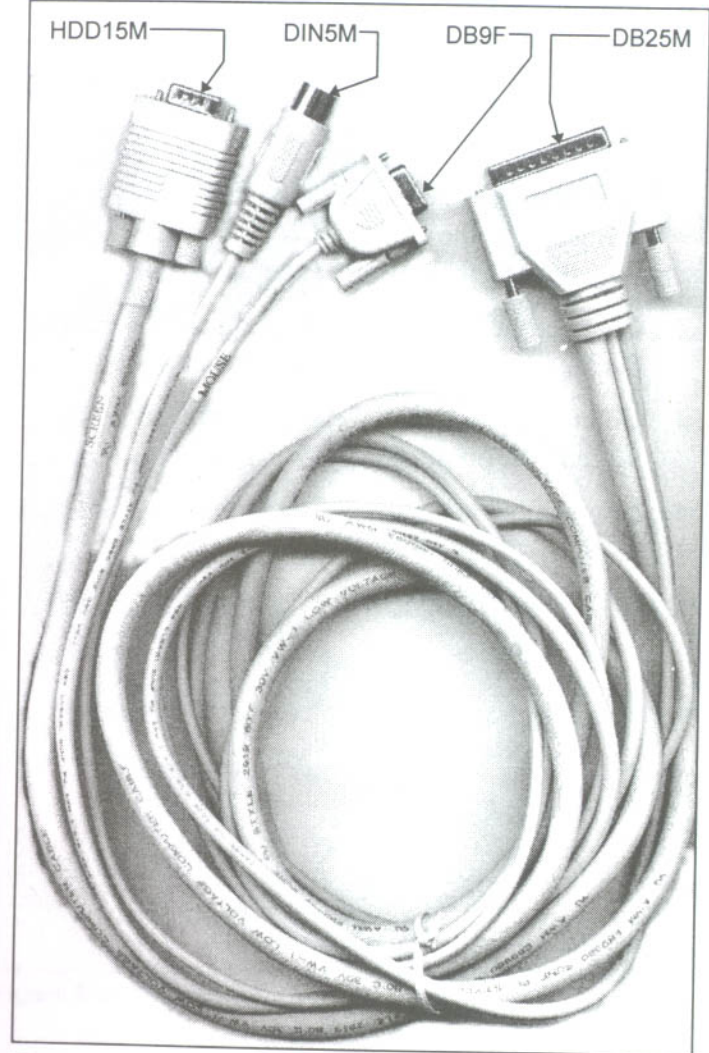

Figure 3-1: CPU Adapter Cable for PC/AT

To connect a PS/2 compatible CPU

To connect each CPU to the Supervisor MU Unit, as Figure 3-2 illustrates, use a CPU Adapter Cable PS/2 as follows:

1. Connect the Adapter Cable's DB25M computer connector to the Computer # port on the Supervisor MU Unit's rear panel.
2. Connect the MiniDIN6M keyboard connector to the keyboard port on the CPU's rear panel.
3. Connect the HDD15M screen connector to the screen port on the CPU's rear panel.
4. Connect the MiniDIN6M mouse connector to the mouse port on the CPU's rear panel.

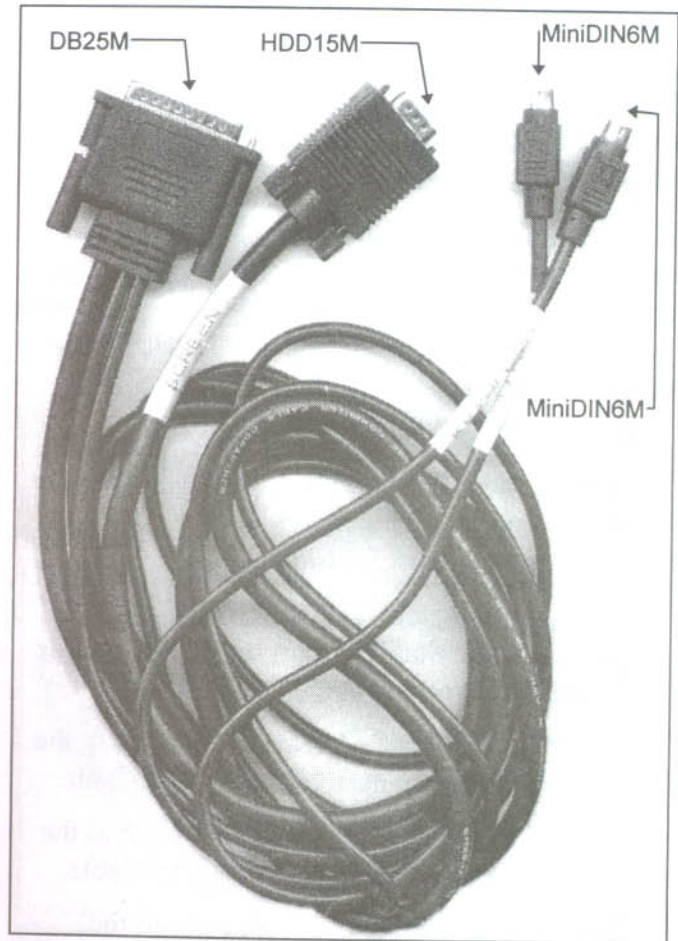

Figure 3-2: CPU Adapter Cable for PS/2

Connecting a Remote KVM Workstation

You can connect up to four KVM Adapter Cables to the Supervisor MU Unit. You use one KVM Adapter Cable to connect the Supervisor MU Unit to each KVM Workstation.

The KVM Adapter Cable consists of a DB25F connector attached to three other connectors, for the keyboard, the video and the mouse. There are different KVM Adapter Cables for PC/AT or PS/2, as Figures 3-3 and 3-4 illustrate.

To connect the PC/AT KVM Adapter Cable

To connect each KVM Workstation to the Supervisor MU Unit, as Figure 3-3 illustrates, use a KVM Adapter Cable PC/AT as follows:

1. Connect the Adapter Cable's DB25F Station connector to the Station # port on the Supervisor MU Unit's rear panel.
2. Connect the keyboard's DIN5M connector to the DIN5F keyboard connector of the KVM Cable.
3. Connect the screen's HDD15M connector to the HDD15F screen connector of the KVM Cable.
4. Connect the mouse's DB9F connector to the DB9M mouse connector of the KVM Cable.

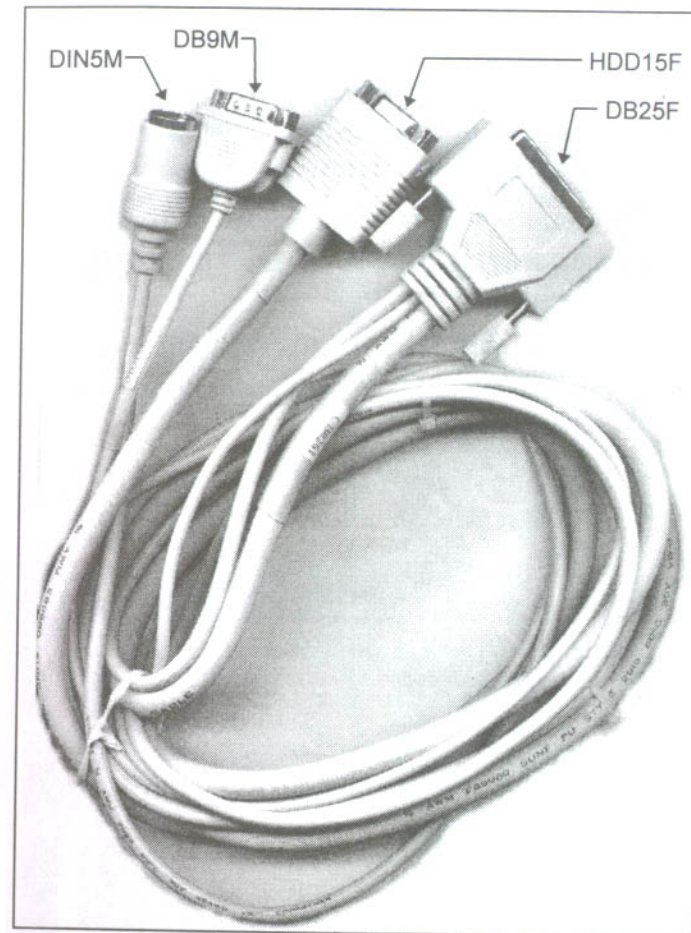

Figure 3-3: The PC/AT KVM Adapter Cable

To connect the PS/2 KVM Adapter Cable

To connect each KVM Workstation to the Supervisor MU Unit, as Figure 3-4 illustrates, use a KVM Adapter Cable PS/2 as follows:

1. Connect the Adapter Cable's DB25F Station connector to the Station # port on the Supervisor MU Unit's rear panel.
2. Connect the keyboard's MiniDIN6M connector to the MiniDIN6F keyboard connector of the KVM Cable.
3. Connect the screen's HDD15M connector to the HDD15F screen connector of the KVM Cable.
4. Connect the mouse's MiniDIN6M connector to the MiniDIN6F mouse connector of the KVM Cable.

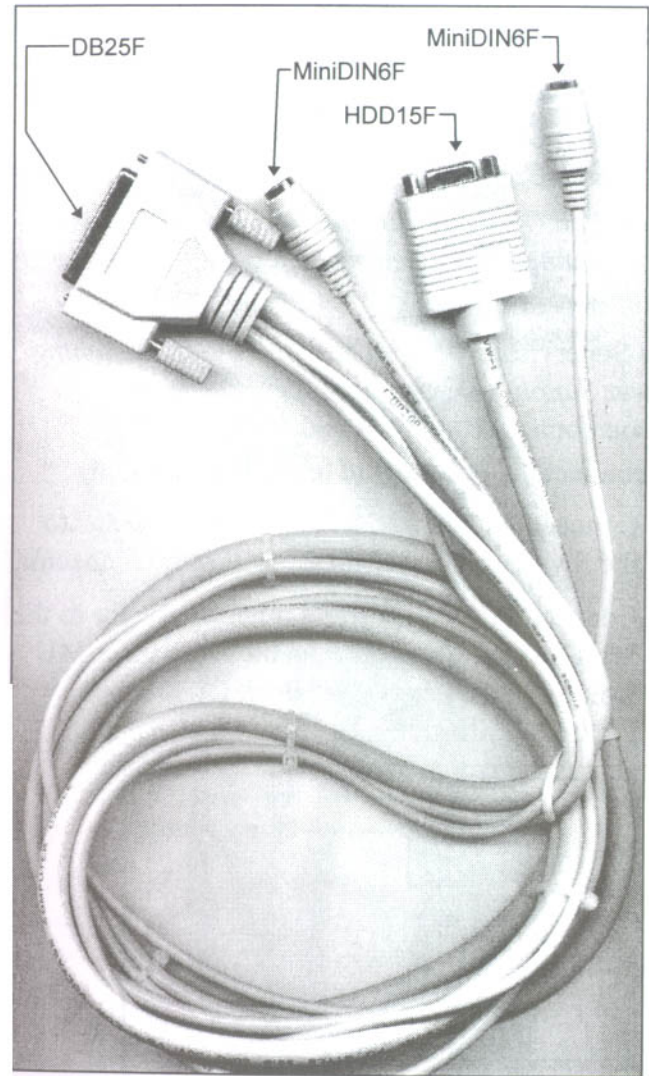

Figure 3-4: The PS/2 KVM Adapter Cable

Supervisor MU Cable Diagrams for PC/AT and PS/2 appear on pages 3-14 and 3-15, respectively.

Connecting the Power Supply

Prior to connecting the power observe the following:

- *Switch On the Supervisor MU Unit **before** you Switch On the CPUs.*
- *Switch Off the Supervisor MU Unit before you disconnect, and then reconnect, a keyboard or a mouse.*

The Supervisor MU Unit has an *Internal Switching Power Supply* adjusting automatically to meet international line voltages and frequencies.

To connect the Power Cord to the Power Supply

1. Connect the Power Cord's Power connector to the Switching Power Supply's Power Connector.
2. Connect the Power Cord's other connector to the Wall Socket. This connects the Supervisor MU Unit to the Power, as the Block Diagram in Figure 3-5 illustrates.

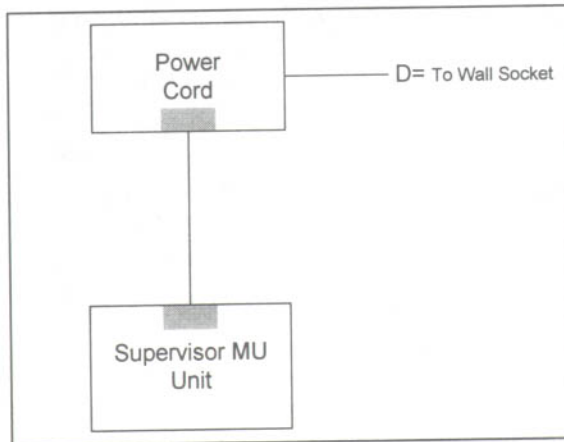

Figure 3-5: The Power Supply Block Diagram

Figures 3-6 to 3-9 illustrate Power Cords suitable for the USA, Europe, and Israel, respectively.

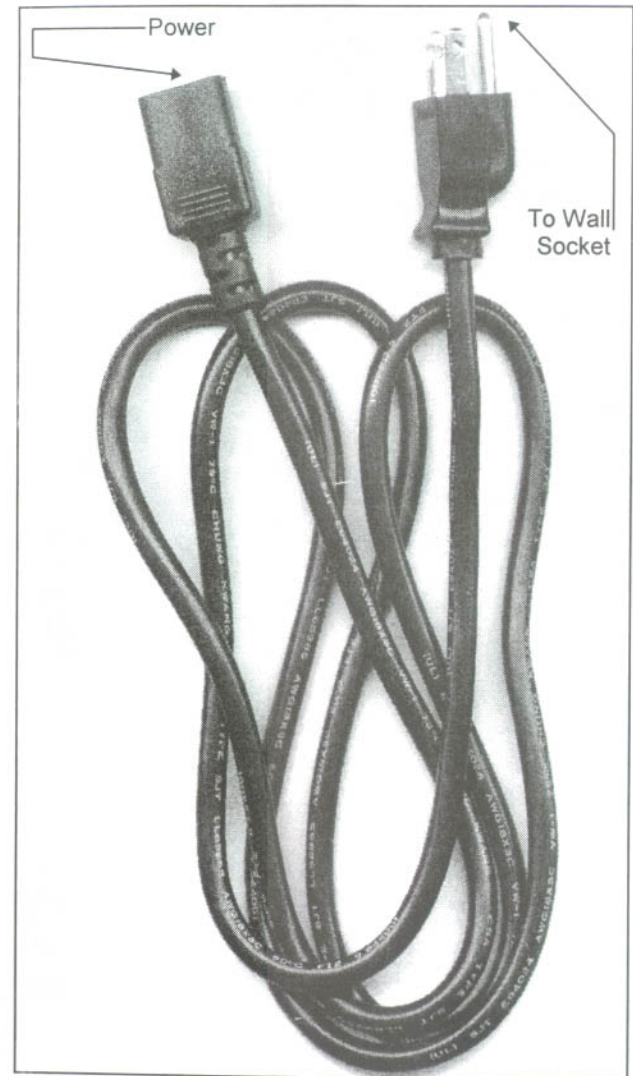

Figure 3-6: Power Cord suitable for USA

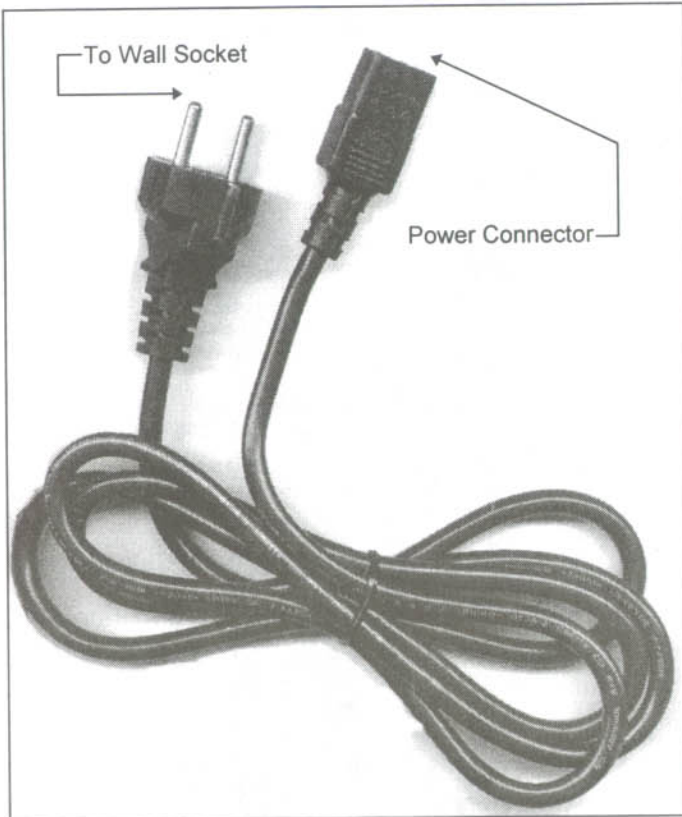

Figure 3-7: Power Cord suitable for Europe

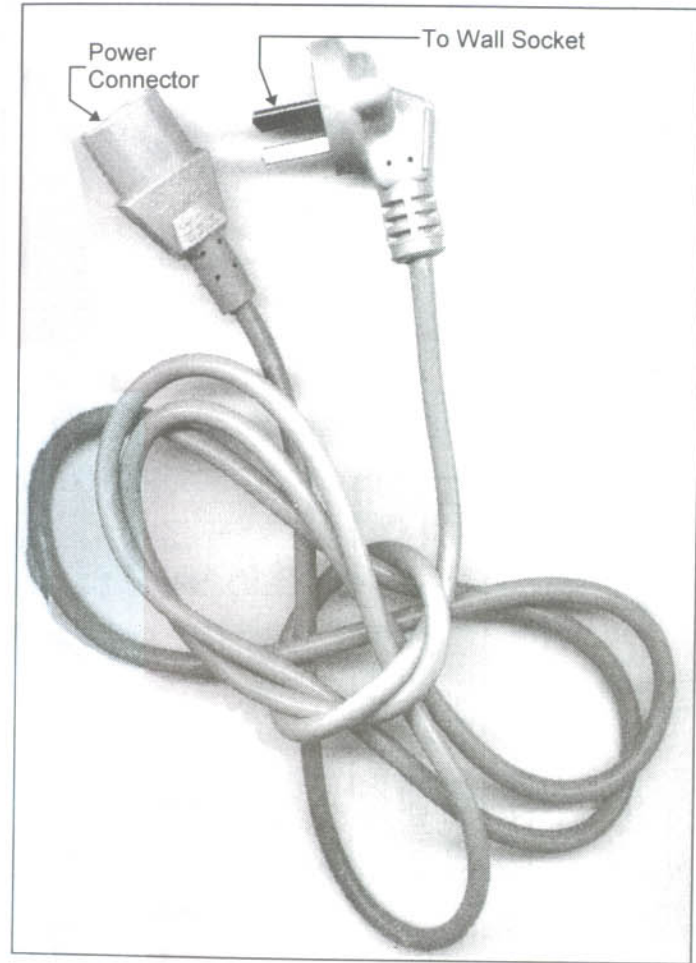

Figure 3-8: Power Cord suitable for Israel

Supervisor MU Cable Diagrams for PC/AT and PS/2 appear in Figures 3-9 and 3-10, respectively.

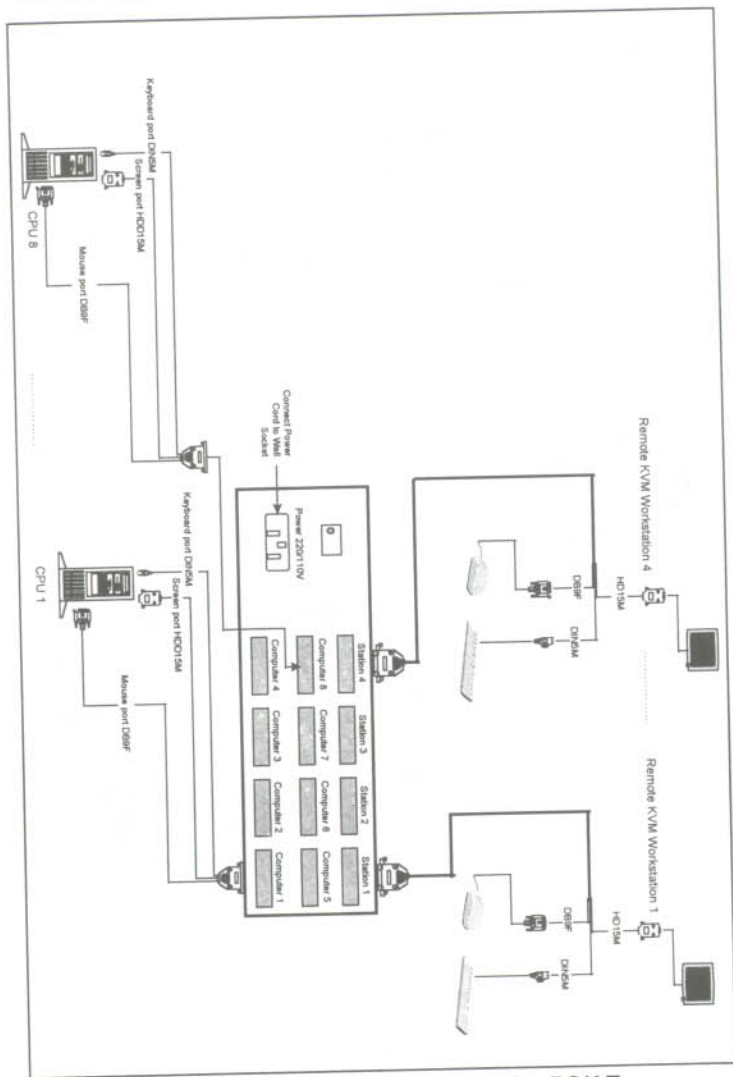

Figure 3-9: Supervisor MU Cable Diagram for PC/AT

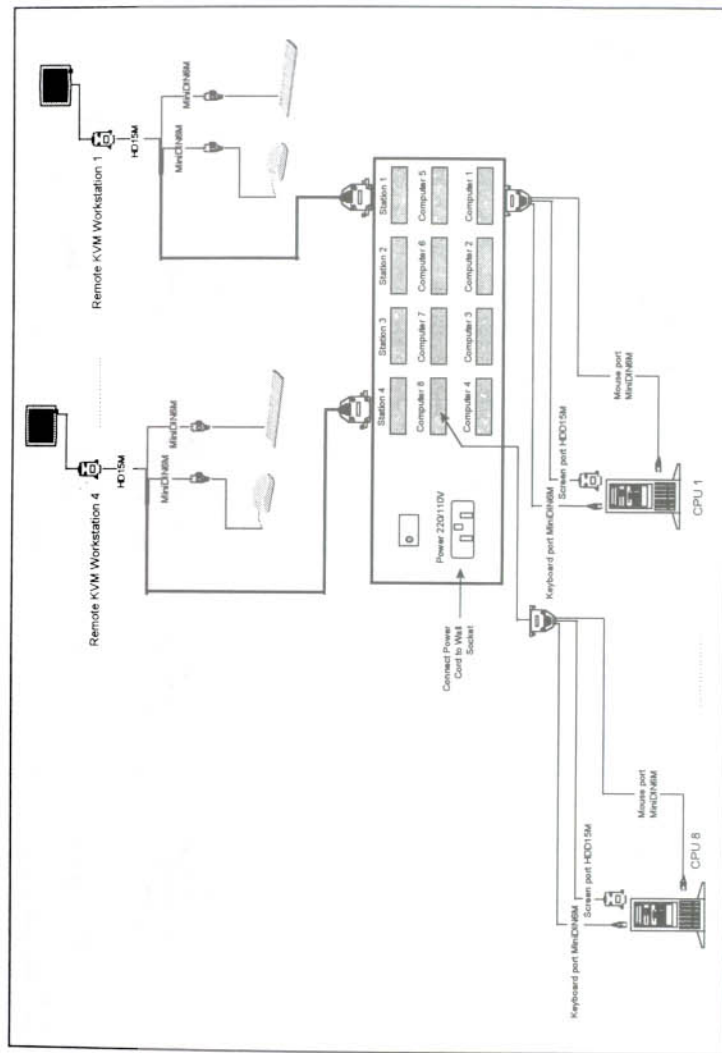

Figure 3-10: Supervisor MU Cable Diagram for PS/2

Chapter 4: The Unit

This Chapter describes the front and the rear panels of the Supervisor MU Unit.

Supervisor MU Unit Front Panel

Figure 4-1 illustrates the front panel. Table 4-1 describes the indicators and operations.

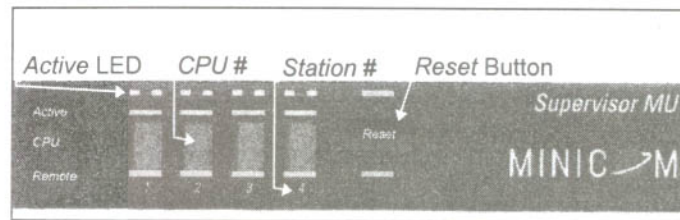

Figure 4-1: Supervisor MU Unit Front Panel

Table 4-1: Supervisor MU Unit Front Panel

Title	Picture	Function
Active LED		Indicates the active Station #
CPU #		Indicates the selected CPU #
Station #		Indicates the Station #
Reset Button		Push to reset

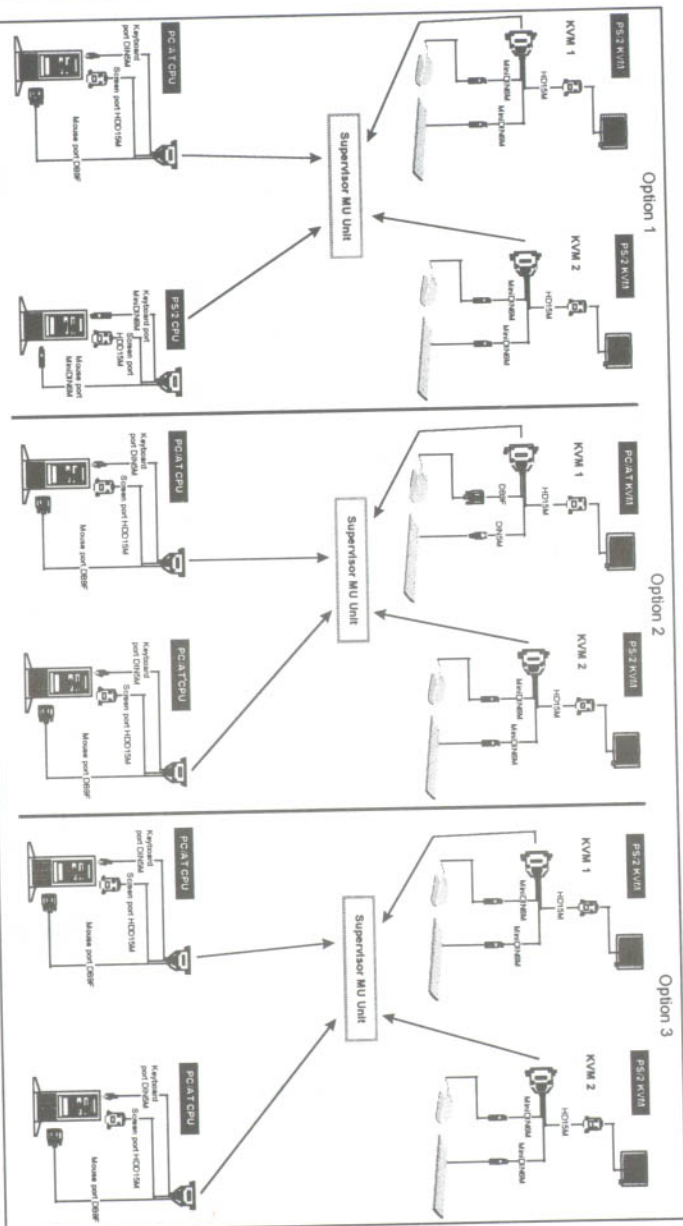

Figure 3-11: Supervisor MU Mixed Options

The Rear Panel Connections

Figure 4-2 illustrates the rear panel. Table 4-2 describes the basic hardware connections.

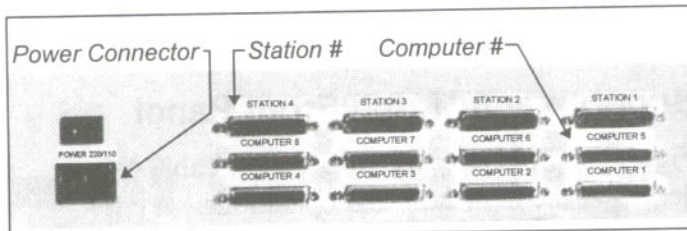

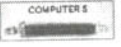



Figure 4-2: Supervisor MU Unit Rear Panel

Table 4-2: Supervisor MU Unit Rear Panel Connections

Title	Picture	Function
Power Switch		Push to turn the Unit On/Off
Computer #		Connect the CPU Adapter Cable's DB25M connector to this port
Station #		Connect the KVM Adapter Cable's DB25F connector to this port
Power Connector		Connect the Power Cord to this connector

Chapter 5: OSD Set Up

This chapter explains setting up the OSD Window.

Firstly, you invoke the OSD Window, so it appears superimposed on your screen.

To invoke the OSD Window

1. Switch On the Supervisor MU Unit and then the computer. The *On* LED illuminates and the *Computer #* LED displays 01.
2. Press the *Shift* key twice on your keyboard. The OSD Window appears superimposed on your screen.
3. Press the *F3* key on your keyboard to setup the OSD Window. You can enter the relevant data, as Figure 5-1 summarizes.

Entering data in the OSD Window

There are 3 parts to the OSD Window, as page 2-2 explains: the upper, the middle, and the lower. This chapter deals with the entering of data in the OSD Window in the:

- Upper part referred to as the *Name Section*
- Middle part referred to as the *Stations Section*

The following chapter, Chapter 6, deals exclusively with operating the middle part of the OSD Window, the *Stations Section*. *Entering data* in the middle part and *operating* the middle part are different actions, but the former is a prerequisite to the latter.

To enter data you need to set up the OSD Window as follows:

To set up the OSD Window

- Press the *F3* key on your keyboard, whilst the OSD Window is superimposed on your screen. The Set up OSD Window appears.

To enter data in the OSD Window's upper part

In the *Name Section*, the Unit comes with the following data entered:

```
Minicom Advanced Systems
Supervisor MU
```

Each visible character is colored blue on a white background. A space constitutes a character. You can substitute this data up to a maximum of 58 characters in 2 lines.

To enter the data in the OSD Window's middle part

In the *Stations Section*, you may insert as follows:

- Up to 28 characters in 1 line before the 1st line.
- Up to 29 characters in 1 line after the 8th line.
- Up to 26 characters in each of the lines 1 to 8.

Each visible character is colored blue on a white background. The Unit is preset with fixed numbering, at the start of each line. You cannot alter this fixed numbering which appears as follows: 1.

The Unit includes data after the fixed number which appears as follows: COMPUTER 1

You can substitute this data with up to 26 characters per line.

Note:

To delete this data, press either the:

- Space* key, if you are at the beginning of the line, keeping it depressed until the whole line is deleted; or
- Backspace* key, if you are at the end of the line, until you reach the 1st character. To delete the 1st character, select it and press the *space* key to delete it.

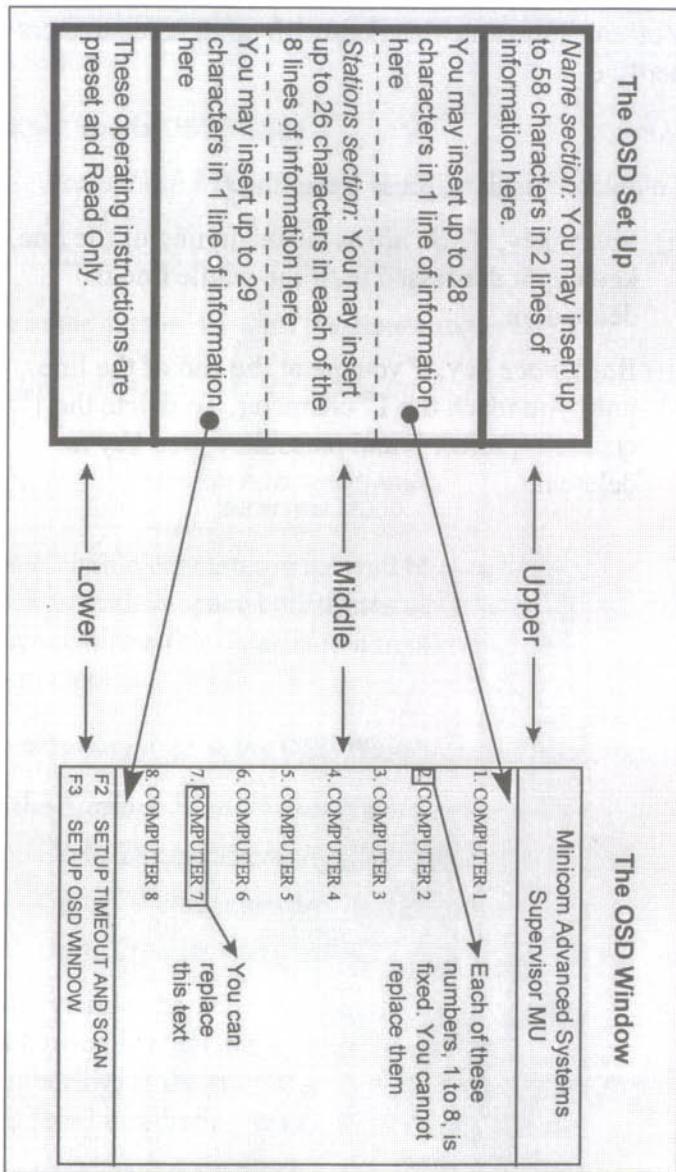

Figure 5-1: Entering Data in the OSD Window

Entering data in the Timeout and Scan Window

To set up the Timeout and Scan

- Press the *F2* key on your keyboard, whilst the OSD Window is superimposed on your screen. The Timeout and Scan Window appears.

Note:

- The Timeout and Scan Window consists of 5 columns, as follows:

Column 1, lists the CPUs, numbered 1 to 8.

Column 2, Timeout, is the period of time after which another User can take control of a CPU once a previous User ceases working on that CPU.

Column 3, Scan, sets the amount of time you view each CPU's screen during the scan.

Column 4, Display, sets the period of time for which you view the CPU's title at the top of the screen.

Column 5, sets the unit of time as seconds.

- Data in columns 2, 3, and 4, is preset at 030 seconds but not fixed. You can alter this data.

- Enter a leading zero where necessary. For example, type 030 for thirty seconds.

- Data in columns 1 and 5, is fixed. You cannot alter this data.

Figure 5-2 illustrates the Timeout and Scan Window.

SETUP SUPERVISOR ON SCREEN DISPLAY				
	TIMEOUT	SCAN	DISPLAY	
1.	030	030	030	SEC
2.	030	030	030	SEC
3.	030	030	030	SEC
4.	030	030	030	SEC
5.	030	030	030	SEC
6.	030	030	030	SEC
7.	030	030	030	SEC
8.	030	030	030	SEC
F1 RETURN TO MAIN MENU				
F3 SETUP OSD WINDOW				

Figure 5-2: The Timeout and Scan Window

By altering the *Timeout and Scan* data, each of the four Users independently determines his OSD Window's *Timeout and Scan* parameters.

To replace data in the Timeout and Scan Window

Each of the four Users can replace data in columns 2, 3, and 4, as follows:

1. Place the cursor on 1 of the 3 digits and type the new number.
2. Press the *Esc* key on your keyboard to exit this Window.

Note:

- (i). You maneuver within the Timeout and Scan Window, vertically, using the *Up* or *Down Arrow* keys on your keyboard.
- (ii). Press the *Tab* key on your keyboard to maneuver horizontally, moving sideways between the *Timeout*, *Scan*, and *Display* columns.
- (iii). You can only type digits and not letters.

This sheet contains 2 additions and 2 changes that update the User's Guide Version 0898A

- [I]. On page 6-4 - before the heading, **To Reset the Mouse**, add the heading: **Changing the Mouse Default Speed**, followed by this text:

To change the Mouse Speed (when mouse response is too slow):

1. Press the *Shift* key twice. The OSD window appears on the screen.
2. Press the *Home* key.
3. Press the *Enter* key. This changes the default mouse speed.

- [II]. On page 6-4 - before the heading, **To Scan the CPUs**, add the heading: **Hotswapping the Mouse**, followed by this text:

To Hotswap the Mouse (when you want to replace the mouse device):

1. Press the Shift key twice. The OSD window appears on the screen.
2. Disconnect and then reconnect the mouse.
3. Press the *Home* key.
4. Press the *Enter* key. This resets the mouse.

- [III]. On page 6-4 - **To Scan the CPUs**:

- Replace the two words, *F4* key, by:

... *Alt* and *F4* keys simultaneously ...

- [IV]. On page 6-5 - **To change the Hotkey from Shift to Ctrl**

- In para. 2 replace the two words , *F9* key, by:

... *Alt* and *F9* keys simultaneously ...

Update: May, 1999

Chapter 6: Operations

This chapter explains how to operate the Supervisor MU System, and in particular, using the OSD. You observe the status of the different CPUs using the OSD Window and on the front panel LED indicators, as page 4-1 explains.

Using the OSD

The first stage in using the OSD is to make the OSD Window appear on your screen. To invoke the OSD Window, do the following:

1. Switch On the Supervisor MU Unit and then the computer. The *On* LED illuminates and the *Computer #* LED displays 01.
2. Press the *Shift* key twice on your keyboard. The OSD Window appears superimposed on your screen.

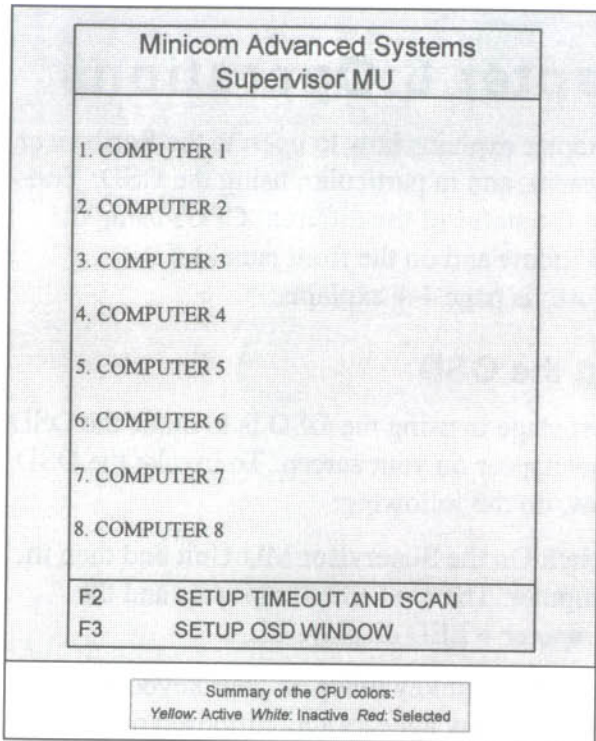

Figure 6-1: Operating the Supervisor MU's OSD

Once the OSD Window appears superimposed on your screen, the next stage is to operate the OSD using the middle part of the OSD Window.

These operating functions include: selecting a CPU, controlling a CPU, closing the OSD Window and resetting the mouse.

To select a CPU

- Press the *Up* or *Down Arrow* keys on your keyboard, to navigate between the list of 8 CPUs until you reach the CPU you want. The selected CPU appears in red letters.

Note:

- You can only navigate amongst the active CPUs, those appearing in yellow letters, as the autoskip function automatically ignores inactive CPUs, which appear in white letters.
- When selecting a CPU, the OSD Window does not indicate if another User is already using that CPU.

The next stage is to gain control of that CPU.

To control a CPU

- Press the *Enter* key once on your keyboard to gain control of the selected CPU's screen. The OSD Window disappears. You see your selected screen, and in addition, for 30 seconds (or the period of time set for *display*), you view the OSD title superimposed at the top of the screen.

Note:

- You can change the preset 30 second default period.
- After pressing the *Enter* key, if the keyboard's *Num Lock*, *Caps Lock*, and *Scroll Lock* lights flash, this indicates that another User is already working on that CPU. You can view that CPU's screen but not operate your keyboard and mouse.

To Close the OSD Window

- Press either the *Enter* or the *Esc* key once on your keyboard. You exit the OSD Window.

Note:

- (i). Once you select a computer that is subsequently switched off, the whole screen including the OSD Window, will be dark.

To Reset the Mouse

To reset the mouse when mouse control is lost, do one of the following. Either:

- Press and release the *Shift* key on your keyboard followed by typing the *R* character within three seconds. This resets the mouse. **Or,**
- Press the *Home* key on your keyboard whilst the OSD Window is superimposed. This resets the mouse.

To Scan the CPUs

After setting up the Timeout and Scan, as page 5-5 explains, you are ready to scan the CPUs.

- While the OSD Window is superimposed on your screen, press the *F4* key on your keyboard. Your screen displays each active CPU one after the other.

Note:

- (i). To exit from the Scan Mode, press the *Shift* key twice on your keyboard. You return to the OSD Window.

To change the Hotkey from *Shift* to *Control*

Instead of invoking the OSD Window by using the *Shift* key on your keyboard, you can use the *Control* key. To change the hotkey, do the following:

1. Press the *Shift* key on your keyboard twice. The OSD Window appears superimposed on your screen.
2. Press the *F9* key on your keyboard.
3. Press the *Esc* or *Enter* key on your keyboard. The OSD Window disappears from your screen. The hotkey is now *Control* and no longer *Shift*.
4. Press the *Control* key on your keyboard twice to test that the hotkey change functions correctly. The OSD Window should appear superimposed on your screen.

Note:

- (i). To revert to *Shift* key operation, repeat the above scenario, substituting the word *Shift* by the word *Control*, and the word *Control* by the word *Shift*.
- (ii). After changing the hotkey from *Shift* to *Control*, to reset the mouse press *Control R*, and not *Shift R* (see page 6-4).

To change the Keyboard Language

The keyboard is preset to US English, but you can change it by pressing the following keys on your keyboard:

1. *F10* key for US English.
2. *F11* key for French.
3. *F12* key for German.

Appendix A: Technical Specifications

Video Monitor Specifications

Video Interface	Video Signal: Analog Signal: Red, Green, Blue 0.7Vp-p/75 Ω positive
	Impedance: 75 Ω
	Horizontal: Sync. positive/negative
	Vertical: Sync. positive/negative
Resolution	Monitor: Up to 1280 x 1024 pixels

Transmission Distances

From MU to CPU: Up to 33ft/10m
From MU to KVM: Up to 20ft/6m

System Requirements

CPUs	IBM AT, PS/2, and their 100% compatibles
Video	SVGA, VGA, or XGA
Keyboard	5-pin din or minidin 6-pin
Mouse	Serial, PS/2

Supervisor MU Unit Specifications

Front LEDs	Active, CPU #
Buttons	Reset
Power	Switching Power Supply 220/110V (70mA)
Dimensions	430mm x 180mm x 88.5mm 16.9" x 7.1" x 3.5"

System Cable Specification

DB25M/ DB25F Connector

CPU Adapter Cable Connectors

	PC/AT	PS/2
To Supervisor MU DB25M	To CPU Ports	
Keyboard	DIN5M	MiniDIN6M
Monitor	HDD15M	HDD15M
Mouse	DB9F	MiniDIN6M

KVM Adapter Cable Connectors

	PC/AT	PS/2
To Supervisor MU DB25F	To CPU Ports	
Keyboard	DIN5F	MiniDIN6F
Monitor	HDD15F	HDD15F
Mouse	DB9M	MiniDIN6F

Appendix B: Supervisor MU Product Line

Order Code	Details & Description
SVMU-2x4	Supervisor MU 2 Users to 4 CPUs
SVMU-4x4	Supervisor MU 4 Users to 4 CPUs
SVMU-2x8	Supervisor MU 2 Users to 8 CPUs
SVMU-4x8	Supervisor MU 4 Users to 8 CPUs
Accessories	
Platform Converter to have a fully mixed configuration for SUN and MAC	
KVM Adapter Cable for the connection of KVM Workstation to Supervisor MU	
CPU Adapter Cable for the connection of CPU to Supervisor MU	
System Cable to extend Adapter Cable length	
Rack mounting sets to install Supervisor in standard 19" rack	