

NOTES

1. WEIGHT - 13 ± 1.5 gms
2. OVERFLOW CAPACITY - 51 ± 3 ml

<p>DISCLAIMER</p> <p>THIS INFORMATION IS PROVIDED AS A GENERAL GUIDE, INCLUDING DIMENSIONS. IT IS THE CUSTOMER'S RESPONSIBILITIES TO SELECT THE PROPER CONTAINER FOR PRODUCT AND APPLICATION COMPATIBILITY.</p>	<p>DISTRIBUTED BY:</p> 	<p>REF NO.:</p> <p>DWG10248</p>
	<p>DESCRIPTION:</p> <p>30 ml PET Foam Bottle</p>	

NO.	PRODUCT CODE	PRODUCT NAME	MATERIALS
1	501-B00000	OVERCAP	PP
2	501-00B000	ACTUATOR	PP
3	601-021112	NET	PP
4	501-000010	PISTON-1	PE
5	501-130000	GASKET	PE
6	501-001000	VALVE	PE
7	501-00000B	CLOSURE	PP
8	501-000020	PISTON-2	PE
9	501-000100	STEM	PP
10	501-400000	HOUSING	PP
11	501-140000	SPRING	SUS-304
12	501-000001	SUB-STEM	PP
13	601-150000	GLASS BALL	GLASS
14	601-160000	DIP TUBE	LDPE

Tube length: From gasket to the bottom 70 ± 1

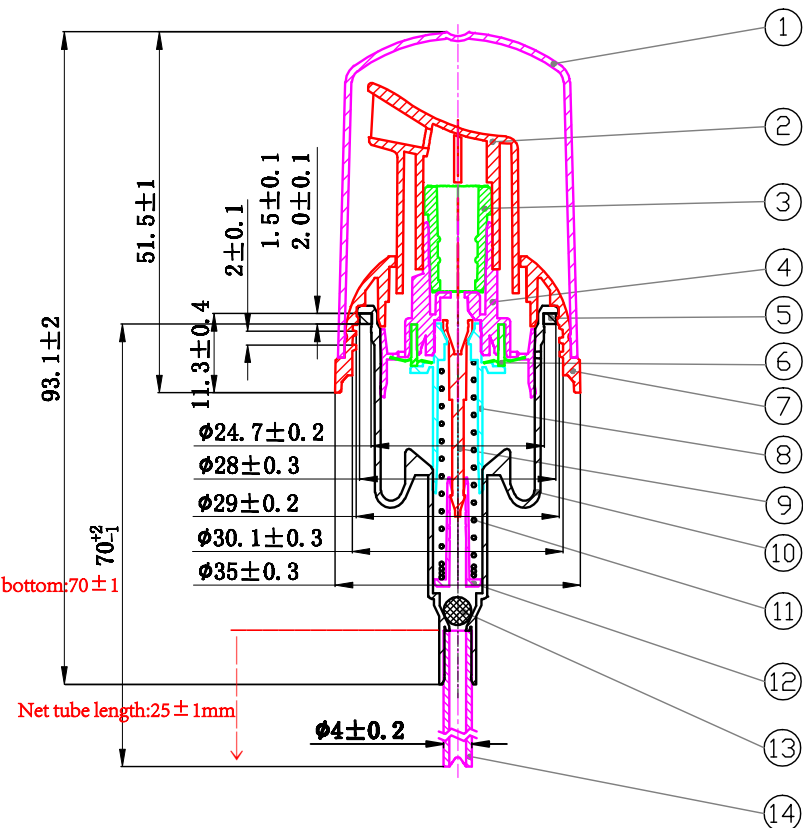

Pump Output: $.4 \pm 0.1$ g

DISCLAIMER

THIS INFORMATION IS PROVIDED AS A GENERAL GUIDE, INCLUDING DIMENSIONS. IT IS THE CUSTOMER'S RESPONSIBILITIES TO SELECT THE PROPER CONTAINER FOR PRODUCT AND APPLICATION COMPATIBILITY.

DISTRIBUTED BY:



REF NO.:

DWG10248

DESCRIPTION:

30 ml PET Foam Bottle