



Assembly Instructions







B1754-090 Maximus Vanity Table
 B1754-091 Maximus Vanity Table Mirror

Thank you for purchasing this quality product. Be sure to check all packing material carefully for small parts, which may have come loose inside the carton during shipment. Identify, count all parts and compare with the **HARDWARE LIST** below.





Caution: Please read the instructions thoroughly before assembly.

1. We recommend that you assemble this product with the assistance of another person: this will make the assembly easier, and will help eliminate damage to the product or injury to persons during assembly.
2. Please do not over tighten screws or bolts until the assembly is completed.
3. Please put all parts on a non-abrasive floor before assembly, and follow the assembly steps to assemble your newly purchased product correctly and efficiently

PART LISTS

NO:	COMPONENT	DRAWING	Q'TY
A	TABLE- L		1PC
B	TABLE-R		1PC
C	FEET		8PCS
D	TABLE MIRROR		1PC
E	SUPPORT		2PCS
F	GLASS		1PC

HARDWARE LISTS

NO:	COMPONENT	DRAWING	Q'TY
1	Bolt Ø1/4"x38mmL		12pcs
2	Lock Washer Ø1/4"		12pcs
3	Flat Washer Ø1/4"x19mm		12pcs
4	Allen key 4mm		1pc
5	Glass clamp		4pcs

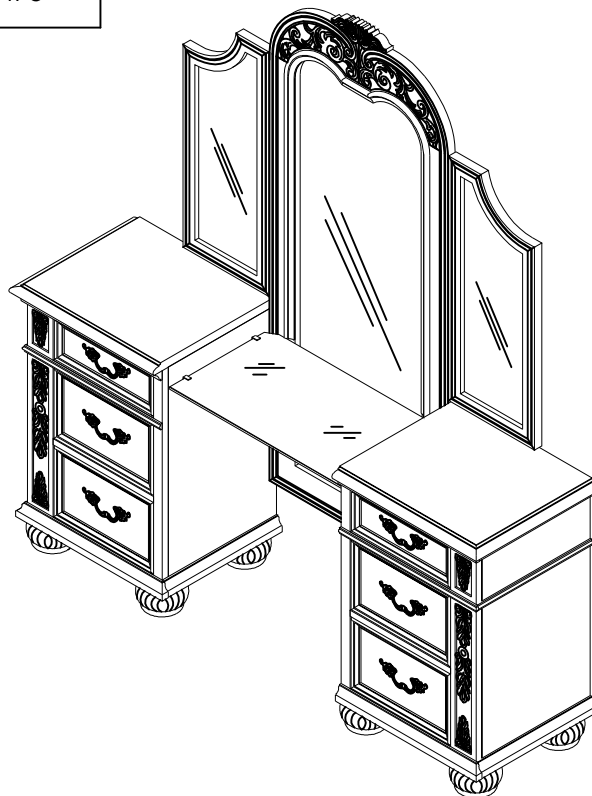

Assembly Instructions

B1754-090 Maximus Vanity Table
B1754-091 Maximus Vanity Table Mirror

STEP 1

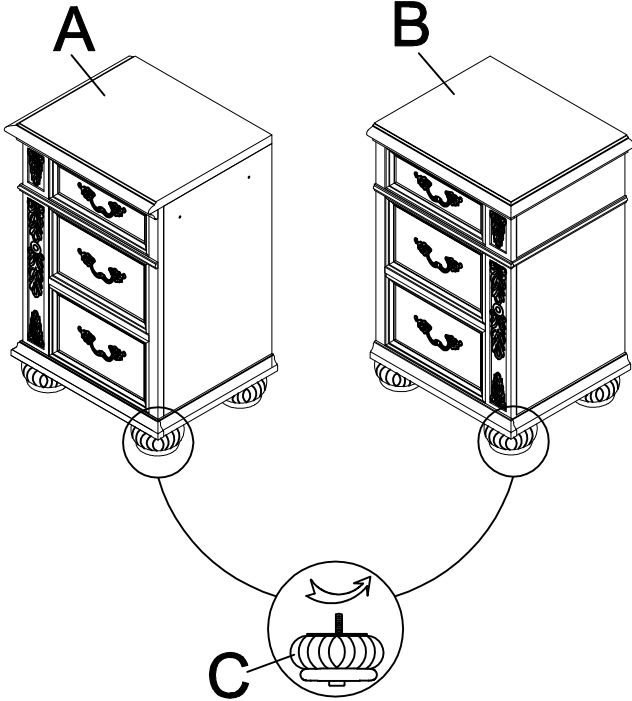

STEP 2

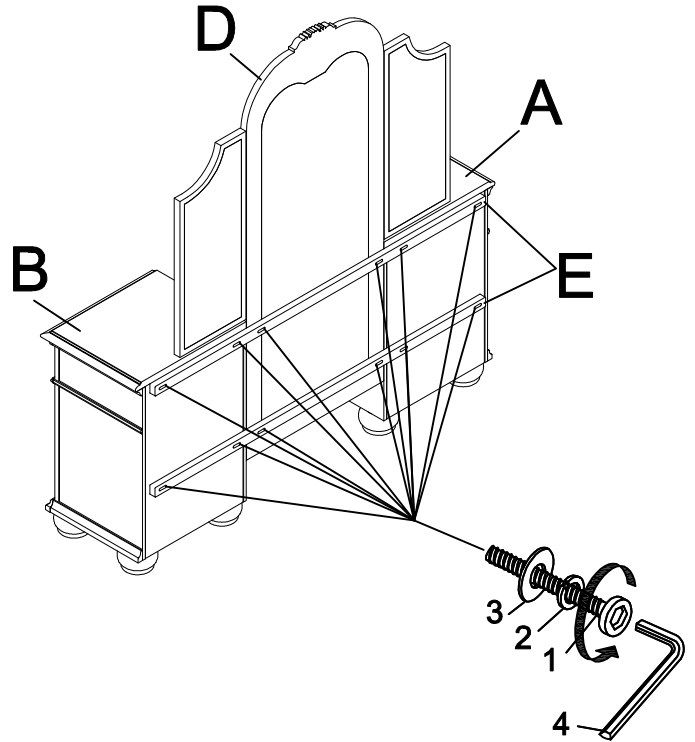

STEP 3

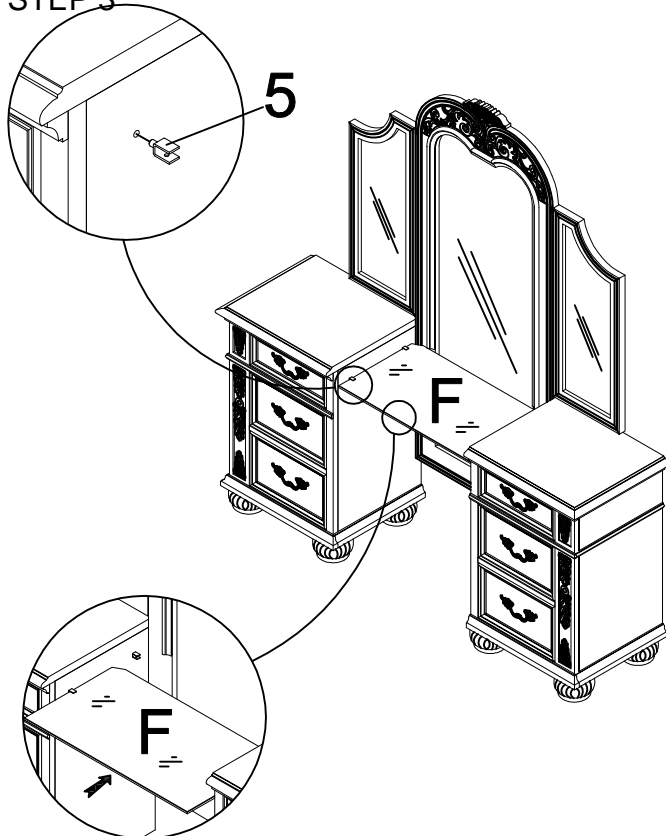

STEP 4

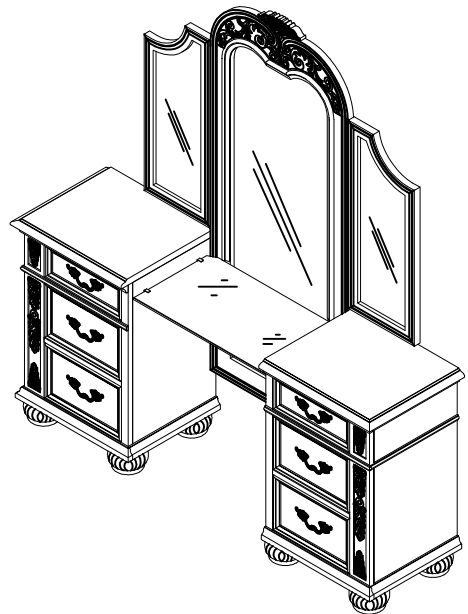



Assembly Instructions



B1754-092 Maximus Vanity Table Stool

Thank you for purchasing this quality product. Be sure to check all packing material carefully for small parts, which may have come loose inside the carton during shipment. Identify, count all parts and compare with the **HARDWARE LIST** below.

Caution: Please read the instructions thoroughly before assembly.

1. We recommend that you assemble this product with the assistance of another person: this will make the assembly easier, and will help eliminate damage to the product or injury to persons during assembly.
2. Please do not over tighten screws or bolts until the assembly is completed.
3. Please put all parts on a non-abrasive floor before assembly, and follow the assembly steps to assemble your newly purchased product correctly and efficiently

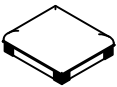
PART LISTS

NO:	COMPONENT	DRAWING	Q'TY
A	SEAT FRAMES		1PC
B	FEET		4PCS

