

TOP  
SCALE 1 : 1

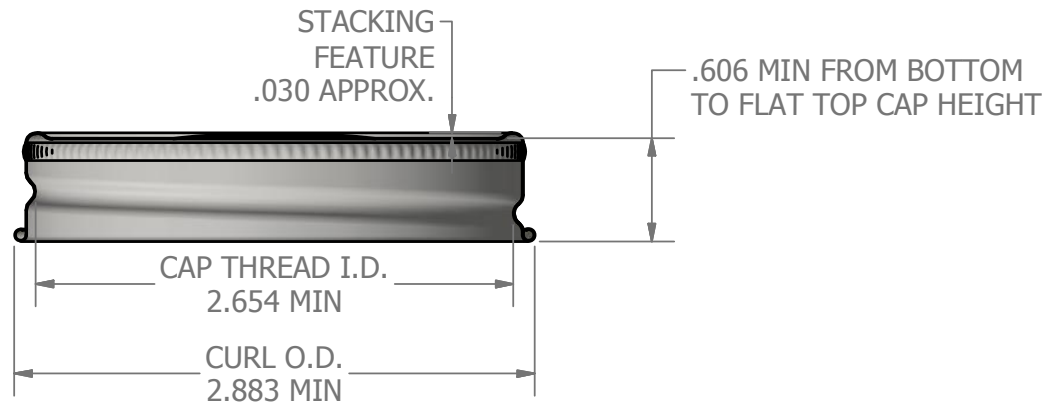

SECTION A-A  
SCALE 1 : 1

NOTES:

- 1) CAPS ARE PRODUCED ACCORDING TO CMA STANDARDS AND ARE SUITABLE FOR GLASS FINISH GPI 70G-450
- 2) DIMENSION OF THREAD INTERNAL DIAMETER TAKEN WITH A PLUG GAGE
- 3) MIN. PLASTISOL THICKNESS 0.025" IF APPLICABLE
- 4) GIVEN THE FLIP PANEL ITS FUNCTION OCCURS BY INNER VACUUM VALUE > 12 inHg. SPECIFICATION OUTSIDE THIS RANGE CAN BE CUSTOMIZED

DISCLAIMER

This specification does not relieve the customer of their ultimate responsibility for the determination of the appropriate container. It is the customer's responsibility to select the appropriate packaging based upon all information at their disposal including the specific application, regulatory compliance, product compatibility and shipping requirements. WE HEREBY DISCLAIM AND EXCLUDE ANY EXPRESS OR IMPLIED WARRANTIES, INCLUDING WITHOUT LIMITATION THE IMPLIED WARRANTIES OF MERCHANTABILITY AND FITNESS FOR A PARTICULAR PURPOSE.

DISTRIBUTED BY:



REF NO.:

DWG32031

DESCRIPTION:

70 mm Metal Screw Cap with Button, Plastisol Liner