

BLACK DIAMOND®

Project Name: _____

Location: _____

Item #: _____

Qty: _____

Black Diamond Warming Proofing and Hot Holding Cabinet, 15.18 Cu. Ft./36 Pan Capacity, in Silver

BDPW36IF



The Black Diamond Warming Proofing and Hot Holding Cabinet is designed for reliable dough proofing and hot food holding in commercial kitchens, featuring a spacious 15.18 Cu. Ft. capacity that accommodates up to 36 full-size sheet pans. Durable aluminum and plastic construction, a reversible clear polycarbonate door, and integrated corner bumpers ensure long-lasting performance and easy use. Nine power levels and two settings with ergonomic knob control provide precise adjustability, while the freestanding design and 5" casters enhance mobility. Covered by manufacturer warranty for peace of mind.

FEATURES AND CONSTRUCTION

- Cabinet features durable aluminum and impact-resistant plastic construction for reliable commercial performance
- Unit operates at 1440 watts and 120V, drawing 12 amps for efficient heating
- Features a single clear polycarbonate reversible door, designed for easy accessibility and visibility
- Offers ergonomic knob controls and up to nine power levels for operational precision
- Operates on standard 120V electric power with NEMA 5-15 plug type
- Freestanding installation offers flexible placement in commercial kitchens
- Temperature easily adjusted via front knob control across two main settings
- Temperature range of 86°F to 203°F supports proofing and hot holding requirements
- Measures 67.7"H x 23"W x 33"D and weighs 154.35 lb

ELECTRIC

120V / 60Hz / 1Ph

Cord Length (Inches): 78.70

Plug Type: NEMA 5-15

Cord set included

NEMA 5-15P



3RD PARTY APPROVALS



WARRANTY (USA / CANADA)

One (1) Year Limited Warranty on Parts and Labor

Contact us for details at 1.877.368.2797



TEMPERATURE

- Temperature Range (Fahrenheit): 86 - 203

INCLUDED COMPONENTS

- Corner bumpers, 5" casters

Black Diamond Warming Proofing and Hot Holding Cabinet

BDPW36IF

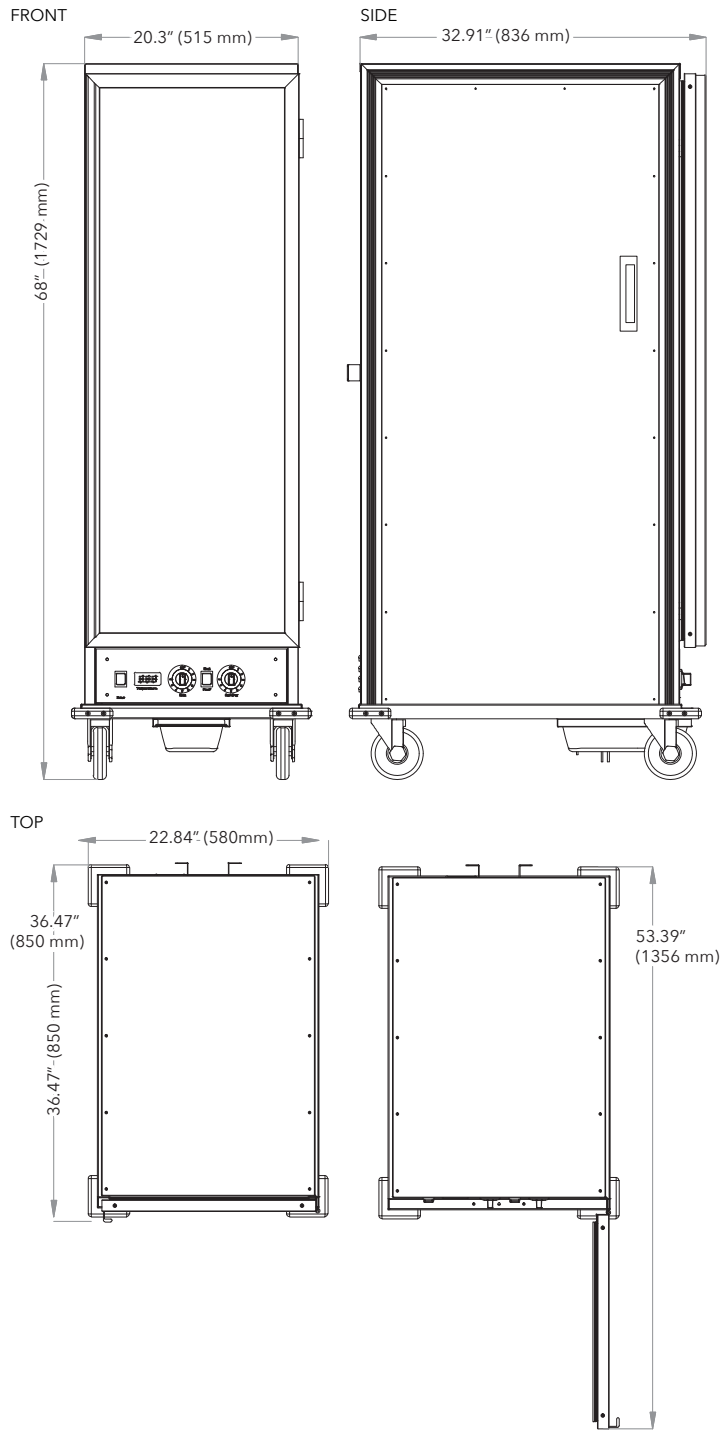

Proofing and Hot Holding Cabinet

Control Type	Amps	Wattage	Shelves	Capacity	Assembled Dimensions L x W x H (in)	Item Weight (lb)	Shipping Weight (lb)
Knob	12	1440	36	15.18 Cu. Ft. (36) Full Size, 18" x 26" Sheet Pans	33.00" x 23.00" x 67.70"	154.4	191.7

Due to periodic changes in designs, methods, procedures, policies and regulations, the specifications contained in this document are subject to change without notice. While we exercise good faith efforts to provide information that is accurate, we are not responsible for errors or omissions in information provided or conclusions reached as a result of using the specifications. By using the information provided, the user assumes all risks in connection with such use.