

► **Code Number**

70001401

► **Description**

Complete HEU system with Battery Powered, Sensor activated Sloan ECOS® urinal Flushometer and vitreous china urinal.

► **Flush Cycle**

0.125 gpf/ 0.5 Lpf

► **SPECIFICATIONS**

Quiet, exposed, diaphragm type, chrome plated urinal flushometer for either left or right hand supply and vitreous china urinal with the following features:

- ADA compliant Sloan Battery powered infrared Sensor for automatic "no Hands" operation
- infrared Sensor with Multiple-focused, Lobular Sensing fields for high and low target detection
- Four (4) Size AA Battery power source factory installed
- "Low Battery" flashing LED
- "User in View" flashing LED
- Infrared Sensor Range Adjustment Screw and Reset Button
- High copper, low zinc brass castings for dezincification resistance
- No external volume adjustment to ensure water conservation
- Adjustable Tailpiece
- PERMEX® Synthetic Rubber Diaphragm with Dual Filtered Fixed Bypass
- 3/4" IPS screwdriver Bak-Chek® angle stop with free spinning, vandal resistant stop cap
- High back pressure vacuum breaker flush connection w/one-piece bottom hex coupling nut
- Spud coupling and flange for 3/4" top spud
- Sweat solder adapter w/cover tube and cast wall flange w/set screw
- Stop seat and vacuum breaker to be molded from PERMEX rubber compound for chloramine resistance

Valve body, cover, tailpiece and control stop shall be in conformance with ASTM Alloy Classification for Semi-Red Brass. Valve shall be in compliance to the applicable sections of ASSE 1037 and ASME A112.19.2/CSA B45.1

**Fixture Specifications**

- Integral flushing rim
- Compliant with Buy American Act when purchased as a combination
- 100% factory flush tested
- Wall hung vitreous china
- Washdown flushing action
- 3/4" IPS top spud inlet
- 2" NPT outlet flange included
- All mounting hardware included
- Carrier not included
- Vandal resistant strainer assembly included
- Compliant to the applicable sections of ASME A112.19.2/CSA B45.1



► **FEATURES**

**Automatic**

Sloan® equipped Flushometers provide the ultimate in sanitary protection and automatic operation. There is no need for AC hookups or wall alterations. The Flushometer operates by means of a Solar powered infrared sensor. Once the user enters the sensor's effective range and then steps away, the Side Mount Operator initiates the flushing cycle to flush the fixture.

**Hygienic**

User makes no physical contact with the Flushometer surface. Helps control the spread of infectious diseases. 24-Hour Sentinel Flush keeps fixture fresh during periods of nonuse.

**Economical**

Automatic operation and a very low flush volume provides water savings over other flushing devices. Reduces maintenance and operation costs. Installation and battery replacement does not require turning off water to the valve.

► **NOTE**

Plumbing System Requirements

Minimum Flowing Pressure: 25 PSI / Minimum Flow Rate: 18 GPM / Maximum Fixture Static Pressure: 80 PSI

► **Compliance & Certifications**



ASME A112.1.3



This space for Architect/Engineer Approval

### ► ELECTRICAL SPECIFICATIONS

#### Control Circuit

Solid state, 6 VDC input

#### Sensor Type

Infrared Convergence Type Object Lock Detection

#### Sensor Range

Nominal 22" – 42" (559 mm – 1067 mm)

Adjustable ± 8" (203 mm)

#### Battery Type

(4) C Alkaline

#### Battery Life

6 Years @ 4,000 flushes/month

#### Indicator Lights

User in View

#### Valve Operating Pressure (Flowing)

15 - 100 psi (104 - 689 kPa)

### ► OPERATION

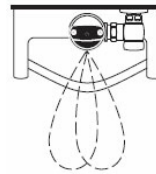

1. A continuous, invisible light beam is emitted from the Sloan ECOS sensor.

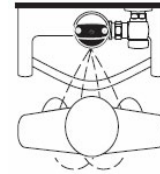

2. As the user enters the beam's effective range (15" to 30") the beam is reflected into the Sloan ECOS scanner window and transformed into a low voltage electrical circuit. Once activated, the output circuit continues in a "hold" mode for as long as the user remains within the effective range of the sensor.

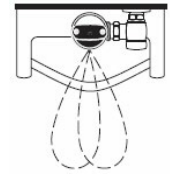

3. When the user steps away from the Sloan ECOS sensor the sensor initiates an electrical signal that operates the solenoid. This initiates the flushing cycle to flush the fixture. The circuit then automatically resets and is ready for the next user.

### DIMENSIONS/ROUGH-IN

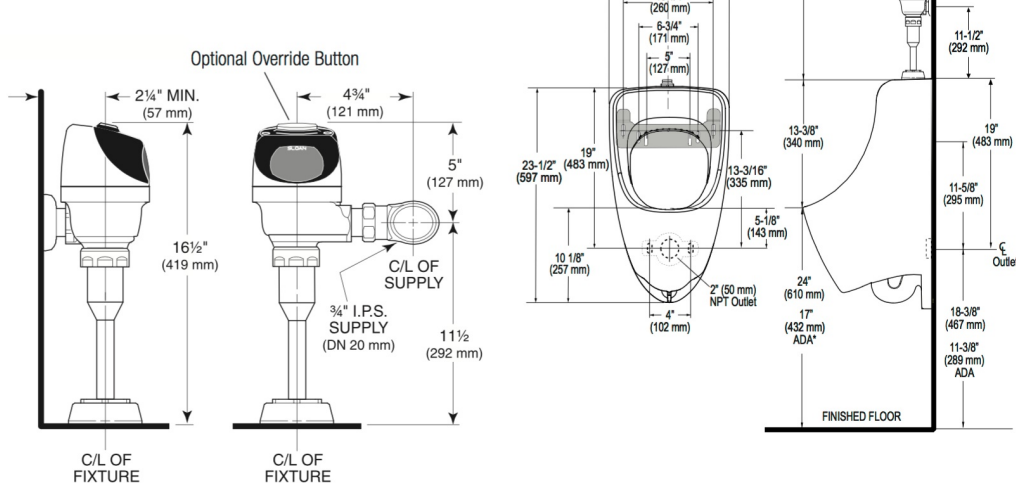

### ► Disclaimer

NOTE: All vitreous china dimensions shown in these drawings are nominal and not to scale. Dimensions can vary within the tolerances established in the governing ASME A112.19.2/CSA B45.1 standard. It is important to consider this when planning rough-in and plumbing layouts.

All information contained within this document subject to change without notice.