

**Bowie**

MODEL #: 260

69.625" x 35.25" x 21.625"



Features an integrated overflow.

**GENERAL SPECIFICATIONS**

**Material** - SculptureStone®

**Installation** - Freestanding

**Soaker Weight** - 320 lbs / 145 kg

**Air Bath Weight** - 350 lbs / 159 kg

**Maximum Fill** - 105 gal to overflow

Must specify on order.

Not recommended as a tub / shower combination.

*NOTE: Filling this tub to the maximum may require an above average size or dedicated water heater.*

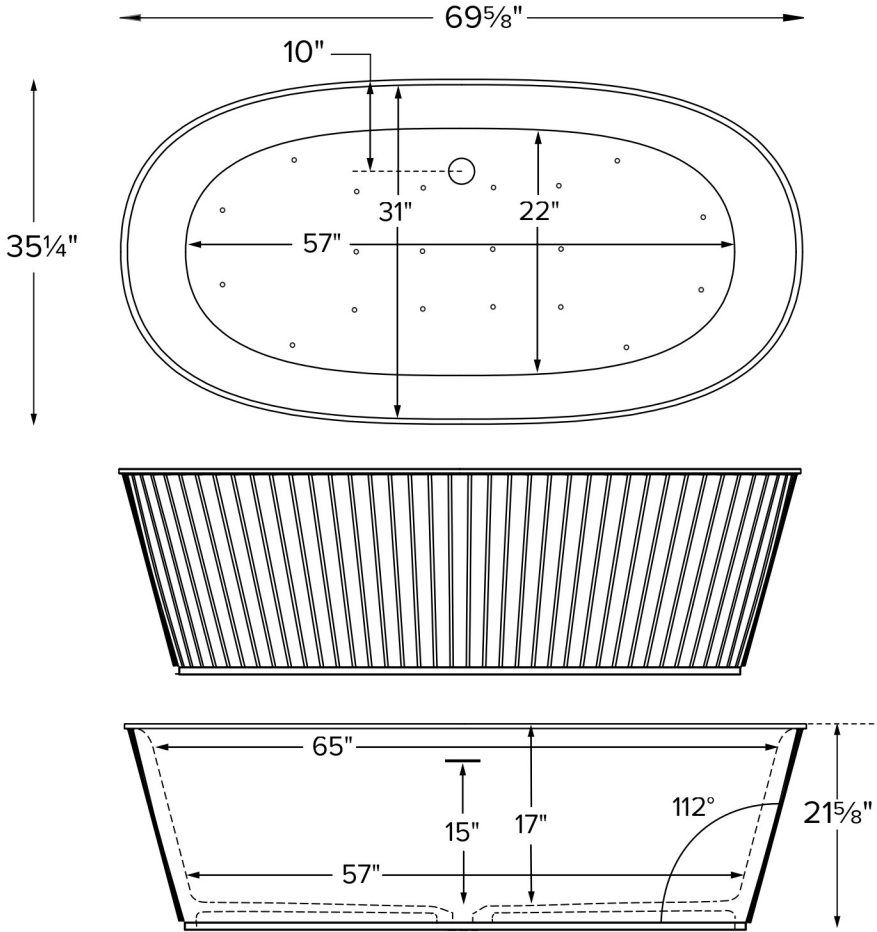

ELECTRICAL COMPONENTS & SPECIFICATIONS		
Required Electrical Service - 110 Volt		
Hydrotherapy Package	Components Included	GFCI
Air Massage	heated blower	1-15 amp
CSA Certified C/US; ANSI Z124.1 and ANSI 112.19.7		

See the Installation & Operation Manual for more details.  
 MTI's Customer Service: Monday-Friday 8am-6pm EST  
 800-783-8827 or service@mtibaths.com

**IMPORTANT ORDERING & INSTALLATION INFORMATION**

- Before ordering or installing, please consider future access to equipment.
- Includes an integrated overflow with toe tap drain in chrome finish. May be specified without an overflow (see local codes before ordering without an overflow).
- Air baths require job site preparation for remote installation of the blower and required check valve. Check valve must be installed higher than the rim of the tub.
- Waterproof remote control included with air bath. Keypad shipped loose may be remote mounted on nearby surface/wall.
- Faucet valves cannot be mounted on this tub model.

• Before discarding tub crate, check for accessories that may be packaged inside.  
 • All product measurements are ±1/2".  
 • Specifications and configurations are subject to change without notice.  
 • Measurements herein supersede all others published prior to publication date below.

