





# HEKMAN®

A HOWARD MILLER COMPANY

## ASSEMBLY INSTRUCTION FOR 23760 DRESSER

HARDWARE LIST			
NO.	ITEM	DESCRIPTIN	QTY.
1		JCB Bolt M6 X 20 MM	12
2		Flat washer M6X18 MM	12
3		Allen wrench	1
4		Bolt M8X13 MM	4
5		Wrench	1

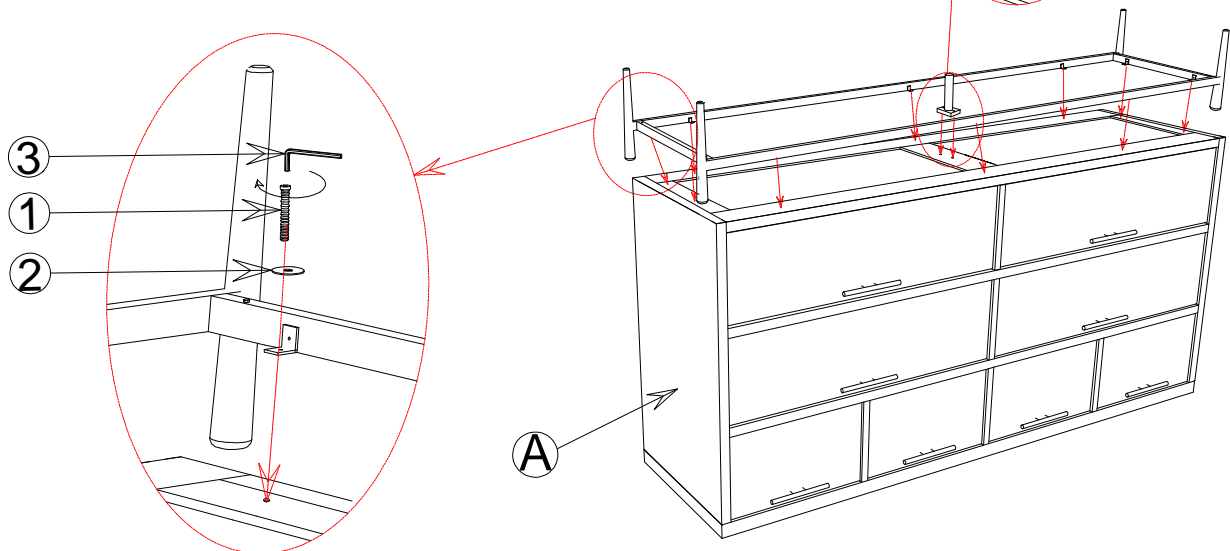
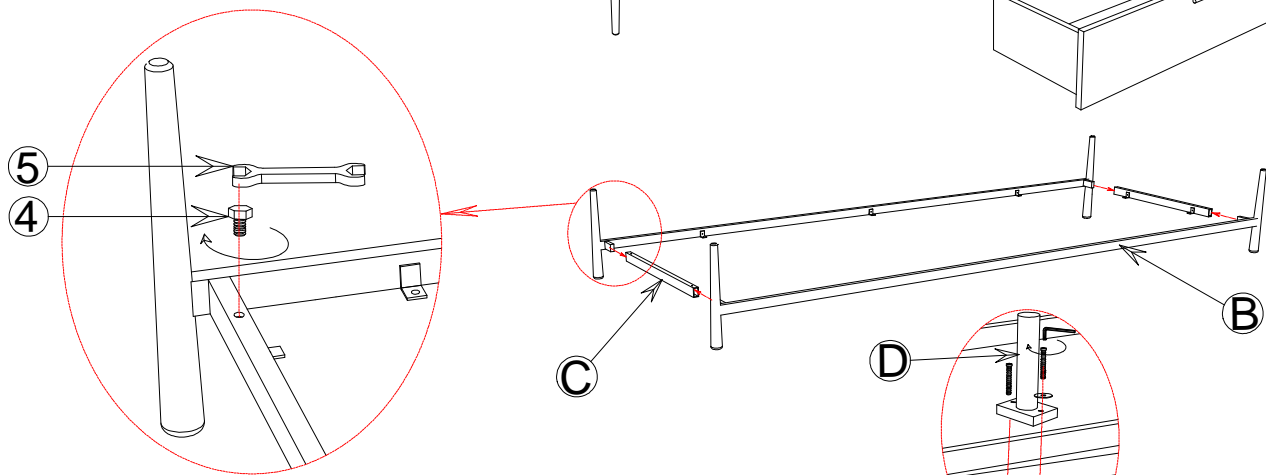
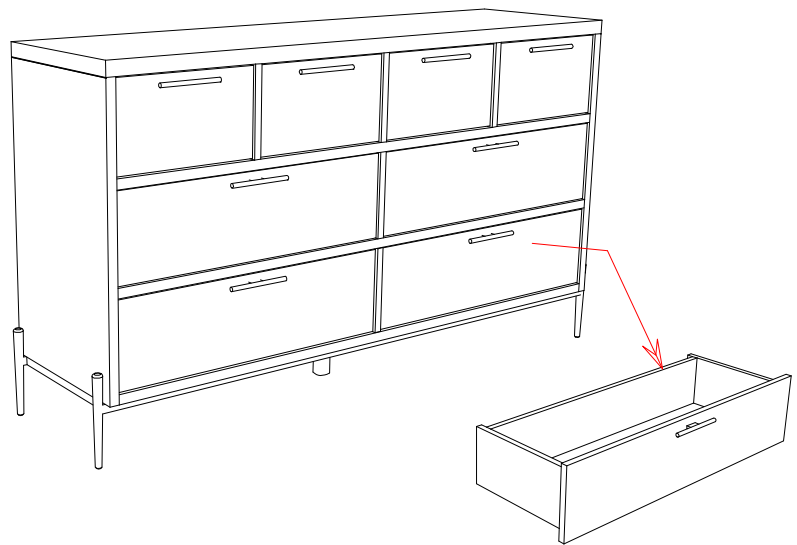

### TO ASSEMBLY :

STEP 1 : Unpack dresser and remove drawers.

STEP 2 : Roll dresser on its back, then its top on a clean, soft surface.

STEP 3 : Thread the JCB bolt(4) to iron leg(B) & iron cross bar(C). tighten end assemblies fully.

STEP 4 : Set base assembly on the upside down case and attach with bolt (1) and washer (2) using allen wrench (3).

STEP 5 : Tighten bolts in step 4 fully with allen wrench (3) & wrench (5).

STEP 6 : Align hole in center leg (D) with holes on bottom of dresser (A) and slide it into position.

STEP 7 : Thread the flat washer(2) , JCB bolt (1) to leg (B) .tighten bolts in step 6 fully with allen wrench (3) then carefully turn the table upright.

STEP 8 : Install drawers.