

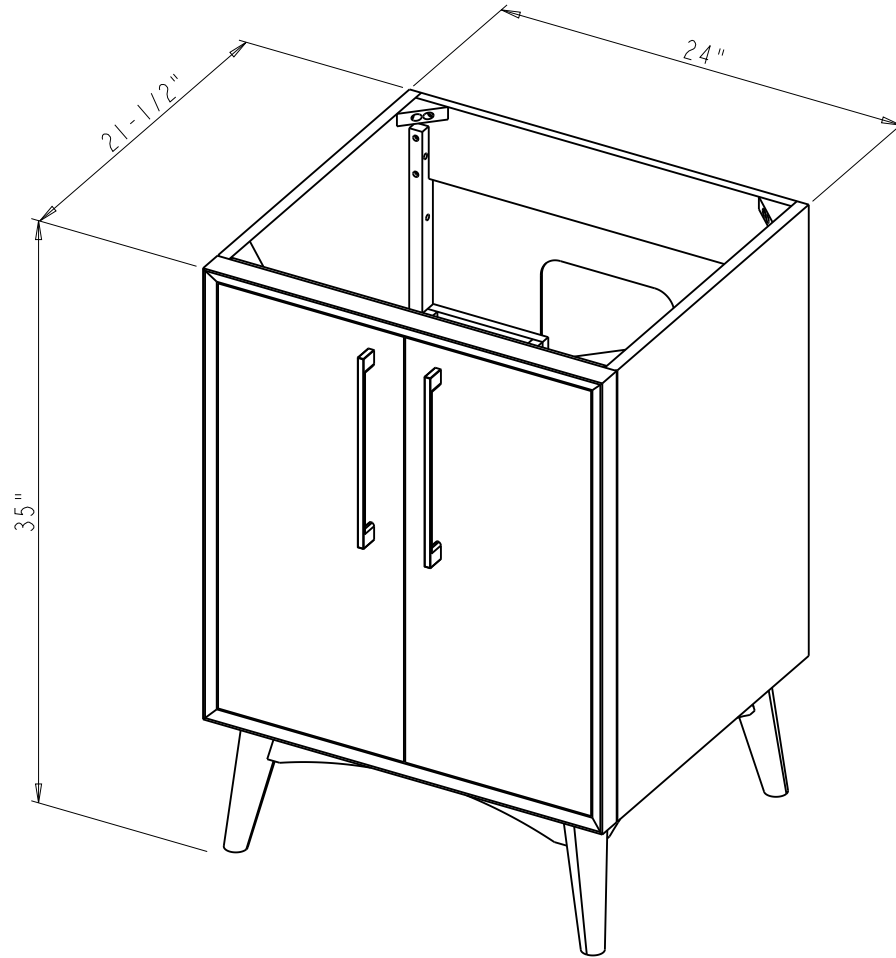

Specification:

1. Finish: See Table
2. Hardware: See Table
3. Hinge: 700.0537.25 + 600.1234.05 (4 pcs)
4. Slide: USE58-300-18 + USCLIP2ND-4W (2 set)
5. leg levelers (4 pcs)
6. The tolerance is +/- 1/8"

Item number	Finish	Deco Hardware	
		Item number	Qty
VN2DAS-24-DW-NT	Dark Walnut	635-256BG	2
VN2DAS-24-NO-NT	Natural Oak	635-256MB	2
VN2DAS-24-WH-NT	White	635-256BG	2

<p>hardware resources</p> <p><small>PROPRIETARY AND CONFIDENTIAL</small></p> <p><small>THE INFORMATION CONTAINED IN THIS DRAWING IS THE SOLE PROPERTY OF HARDWARE RESOURCES INC. ANY REPRODUCTION IN PART OR AS A WHOLE WITHOUT THE WRITTEN PERMISSION OF HARDWARE RESOURCES INC. IS PROHIBITED.</small></p> <p><small>DO NOT SCALE DRAWING</small></p>	ITEM#: VN2DAS-24	MATERIAL:
	FINISH:	WEIGHT: 9
	PROJECTION	
	TOLERANCE UNLESS OTHERWISE SPECIFIED: X ±0.20 X.X ±0.10 X.XX ±0.05 ANGULAR: ±0.5°	UNITS: DRAWN BY: Hugo.cai
SIZE:	APPROVED BY:	DATE:
SHEET:	RELEASE LEVEL:	REVISION:



	ITEM#: VN2DAS - 24		MATERIAL:		
	FINISH:		WEIGHT: 9		
<p>PROPRIETARY AND CONFIDENTIAL</p> <p>THE INFORMATION CONTAINED IN THIS DRAWING IS THE SOLE PROPERTY OF HARDWARE RESOURCES INC. ANY REPRODUCTION IN PART OR AS A WHOLE WITHOUT THE WRITTEN PERMISSION OF HARDWARE RESOURCES INC. IS PROHIBITED.</p>	TOLERANCE UNLESS OTHERWISE SPECIFIED:		UNITS:		
	X ±0.20		DRAWN BY: <i>Hugo.cai</i>		
	X.X ±0.10		DATE: Jan-09-23		
	X.XX ±0.05		APPROVED BY:		
ANGULAR: ±0.5°		SHEET:		RELEASE LEVEL:	
DO NOT SCALE DRAWING		SHEET:		REVISION:	

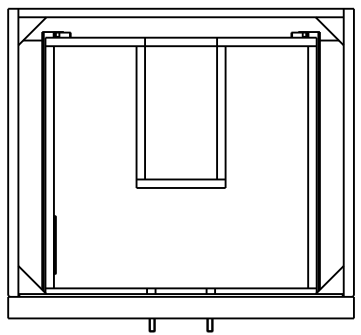
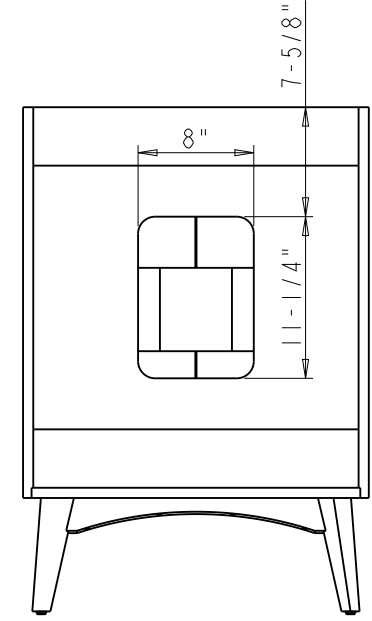
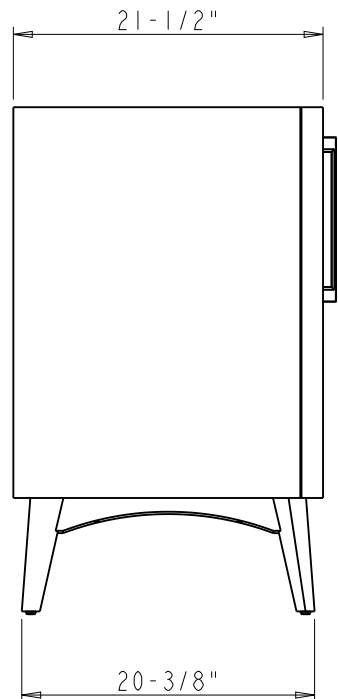
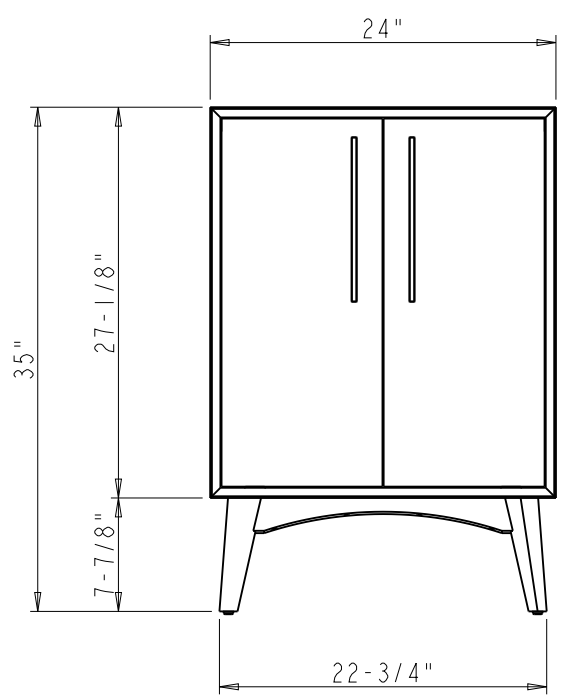

	ITEM#: VN2DAS-24		MATERIAL:	
	FINISH:		WEIGHT:	
<p>PROPRIETARY AND CONFIDENTIAL</p> <p>THE INFORMATION CONTAINED IN THIS DRAWING IS THE SOLE PROPERTY OF HARDWARE RESOURCES INC. ANY REPRODUCTION IN PART OR AS A WHOLE WITHOUT THE WRITTEN PERMISSION OF HARDWARE RESOURCES INC. IS PROHIBITED.</p>	UNITS:		DRAWN BY: <i>Hugo.cai</i>	
	TOLERANCE UNLESS OTHERWISE SPECIFIED: X ±0.20 X.X ±0.10 X.XX ±0.05 ANGULAR: ±0.5°		DATE: Jan-09-23	
	DO NOT SCALE DRAWING		APPROVED BY:	
			DATE:	
	SHEET:		RELEASE LEVEL:	
			REVISION:	

