

LINK

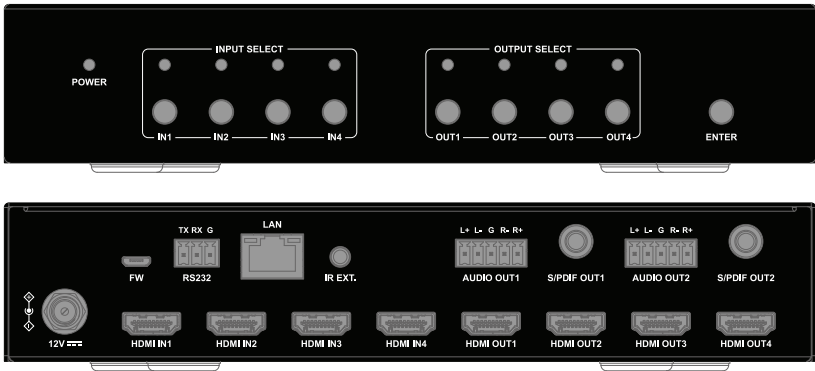

MV4X4-4KUHD 4x4 Matrix, Tiler, or 2x2 Video Wall Switcher

User Manual



Table of Contents

Introduction	3
Overview	3
Features.....	3
Package Contents	4
Specifications.....	5
Panel Description.....	6
Installation and Wiring.....	8
Installation.....	8
Wiring	9
Button Control	13
IR Control.....	13
Command Control.....	14
Obtain IP Address of the Device	15
Web UI.....	16
Matrix Control	18
Video Mode	18
HDMI A/V Mute.....	28
De-embedded Audio Mute	28
Video output resolution	28
Presets Matrix Control	30
General Setting.....	30
Source Naming.....	30
Zone Naming	31
Advanced Setting.....	31
Lower Power Mode.....	31
EDID Preset.....	31
EDID Read	32
CEC Control	33
HDCP	33

Change Login Password.....	34
Network	34
Custom Web UI Logo	35
System Version.....	35
FW Update	35
System.....	36
Log.....	36
Firmware Upgrade	37

Introduction

Overview

This product is a full 4K 4 x 4 HDMI seamless matrix switcher. It features compact enclosure, instant switching and free scaling up to 4K@60Hz SDR and HDR on all outputs. It also supports two additional working modes including multiview and videowall. In matrix switcher mode, it allows four sources to be switched to four HDMI outputs seamlessly. In multiview mode, it features 5 layout modes, including Original, Dual view, PIP, Master and Quad. In videowall mode, the matrix supports 2x2 videowall layout, which can select any input for videowall outputs, configure bezel correction and set image rotation.

Besides flexible video features, it also provides both analog and digital S/DPDIF audio de-embedding for outputs 1&2. The product can be easily managed and controlled, for example, through front panel buttons, IR, RS232, web UI and TCP protocols.

Features

- Seamless switching without seeing black screen between four HDMI inputs and outputs.
- Each HDMI input and output support video format up to 4K@60Hz SDR and HDR.
- HDCP 2.3 and backward compatible.
- EDID management including EDID presets, EDID copy and custom EDID.
- Advanced video processing capabilities:
 - ✓ Supports free scaling between 480p and 4K@60Hz.
 - ✓ Supports conversion between SDR and HDR formats.

- ✓ Supports conversion on color space, chroma and color bits.
- ✓ Supports instant switching between sources so black screen transition is avoided.
- ✓ Supports rich scaler processing modes, including auto scaler, manual scaler and video bypass.
- Supports three video working modes:
 - ✓ Supports matrix switcher mode, which can route any input to any output;
 - ✓ Supports multiview mode, including Original mode, Dual view mode, PIP mode, Master mode, and Quad mode;
 - ✓ Supports videowall mode (2x2 layout), and configuring its output distribution, bezel correction, input selection, and image 180° rotation (to facilitate 2x2 videowall setup using TV display) through API commands and web UI.
- Can be easily managed and controlled through front panel buttons, IR, RS232, web UI and TCP protocols.
- Supports firmware upgrade through web UI and Micro USB port.

Package Contents

- 1 x Matrix Switcher
- 1 x DC 12V 3A Power Adapter
- 1 x IR Remote Controller
- 1 x IR Receiver Cable
- 1 x AC Power Cord (with US Pins)
- 1 x 3.5mm 3-Pin Phoenix Male Connector
- 2 x 3.5mm 5-Pin Phoenix Male Connector
- 4 x Mounting Brackets (with Screws)

Specifications

Technical	
Input/Output Port	4 x HDMI IN, 4 x HDMI OUT, 1 x RS-232, 1 x LAN (RJ45), 2 x S/PDIF OUT, 2 x Analog AUDIO OUT, 1 x FW (Micro USB), 1 x DC 12V
Input/Output Signal Type	HDMI with 4K@60Hz 4:4:4
Input/Output Resolution Supported	<p>VESA: 800x600⁸, 1024x768⁸, 1280x768⁸, 1280x800⁸, 1280x960⁸, 1280x1024⁸, 1360x768⁸, 1366x768⁸, 1440x900⁸, 1600x900⁸, 1600x1200⁸, 1680x1050⁸, 1920x1200⁸</p> <p>SMPTE: 720x576P⁶, 1280x720P^{6,7,8}, 1920x1080P^{2,5,6,7,8}, 3840x2160^{2,3,5,6,8}, 4096x2160^{2,3,5,6,8}</p> <p>2 = at 24 Hz, 3 = at 25 Hz, 5 = at 30 Hz, 6 = at 50 Hz, 7 = at 59.94 Hz, 8 = 60 Hz</p>
Audio Format	<ul style="list-style-type: none"> • HDMI IN/OUT: Fully supports audio formats in HDMI 2.0 specification, including PCM 2.0/5.1/7.1, Dolby TrueHD, Dolby Atmos, DTSHD Master Audio and DTS:X • AUDIO OUT: Balance stereo audio • S/PDIF OUT: PCM 2.0/5.1, Dolby digital and DTS up to 5.1 Channel
Maximum Data Rate	18Gbps
Control Method	Front Panel Buttons, RS232, IR, LAN (Telnet & Web UI)

General	
Operating Temperature	0°C to 45°C (32°F to 113°F)
Storage Temperature	-20°C to 70°C (-4°F to 158°F)
Humidity	10% to 90%, non-condensing
ESD Protection	Human-body Model: ±8kV (Air-gap discharge)/ ±4kV (Contact discharge)
Power Supply	DC 12V
Power Consumption (Max)	16W
Device Dimension (W x H x D)	215mm x 42mm x 140.2mm/8.46" x 1.65" x 5.52"
Product Weight	1.2kg/2.64lbs

Transmission Distance

Cable Type	Range	Supported Video
HDMI	Input: 15m/50ft Output: 10m/33ft	1080P@60Hz 24bpp
	Input/Output: 10m/33ft	4K@30Hz 4:4:4 24bpp 4K@60Hz 4:2:0 24bpp
	Input/Output: 3m/10ft	4K@60Hz 4:4:4 24bpp

Panel Description

Front Panel

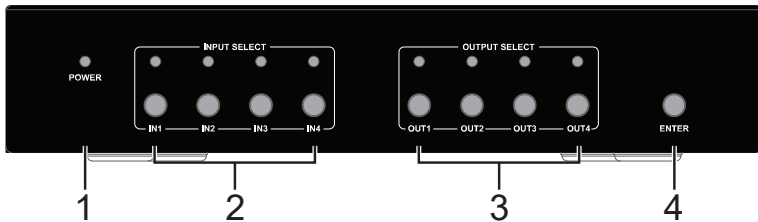

ID	Name	Description
1	Power LED	<ul style="list-style-type: none"> On: The device is powered on. Off: The device is powered off.
2	INPUT SELECT	<p>Input selection LEDs and buttons for input ports (1-4).</p> <ul style="list-style-type: none"> LED On: The input port is selected. LED Blinking: The input port is routed to a specific output. LED Off: The input port is not selected. <p>Input selection buttons (1-4): press to select specific input port.</p>
3	OUTPUT SELECT	<p>Output selection LEDs and buttons for output ports (1-4).</p> <ul style="list-style-type: none"> LED On: The output port is selected. LED Blinking: The output port is routed to a specific input port. LED Off: The output port is not selected. <p>Output selection buttons (1-4): press to select</p>

ID	Name	Description
		specific output port.
4	ENTER	<ul style="list-style-type: none"> Press this button to perform the input and output selection. Hold the button for about 10s to reset the IP settings of the device.

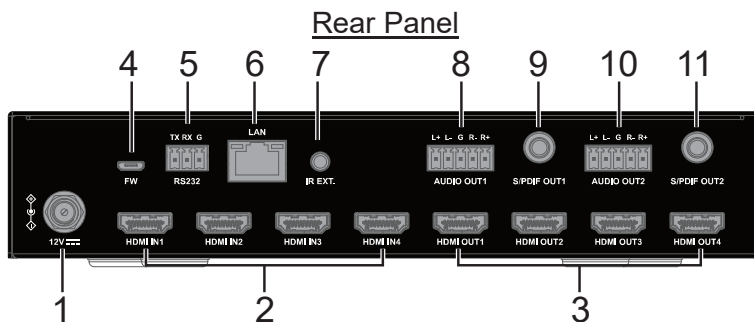

ID	Name	Description
1	12V	Connect to the power adapter and AC power cord provided for power input.
2	HDMI IN (1-4)	Connect to the HDMI source devices.
3	HDMI OUT (1-4)	Connect to the HDMI display devices.
4	FW	Connect to the PC for firmware (ARM module) upgrade.
5	RS232	Connect to the PC for RS232 control on this device.
6	LAN	Connect to a network device (e.g., network switch, router, computer, etc.) for LAN control (Web UI & Telnet).
7	IR EXT.	IR extension port. Connect to the IR receiver cable.
8	AUDIO OUT1	Analog audio de-embedded output from HDMI out 1. Connect to an amplifier or a speaker.
9	SPDIF OUT 1	Digital audio de-embedded output from HDMI out 1. Connect to an A/V receiver or similar.
10	AUDIO OUT2	Analog audio de-embedded output from HDMI out 2. Connect to an amplifier or a speaker.
11	SPDIF OUT2	Digital audio de-embedded output from HDMI out 2. Connect to an A/V receiver or similar.

Installation and Wiring

Warnings:

- Before installation and wiring, disconnect power from the device.
- During wiring, connect and disconnect the cables gently.

Installation

1. Attach the bracket to one side of the enclosure using the screws provided. The bracket is attached to the enclosure as shown.

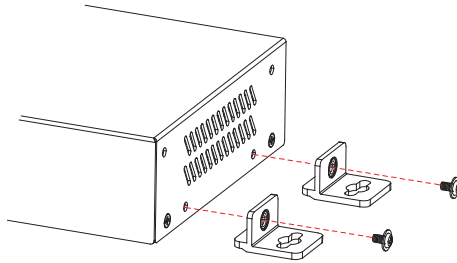

2. Repeat step 1 for the other side of the enclosure.
3. Attach the brackets to the surface or location desired using screws (not included in the package).

Wiring

The matrix supports three video working mode, including matrix switcher mode, multiview mode and videowall mode to meet different application requirements. Users can select working mode and configure corresponding settings through API commands or web UI. Detail information, please refer to the separate document “[API Command Set_MV4X4-4KUHD](#)” or “[Web UI](#)” section.

Matrix Switcher Mode

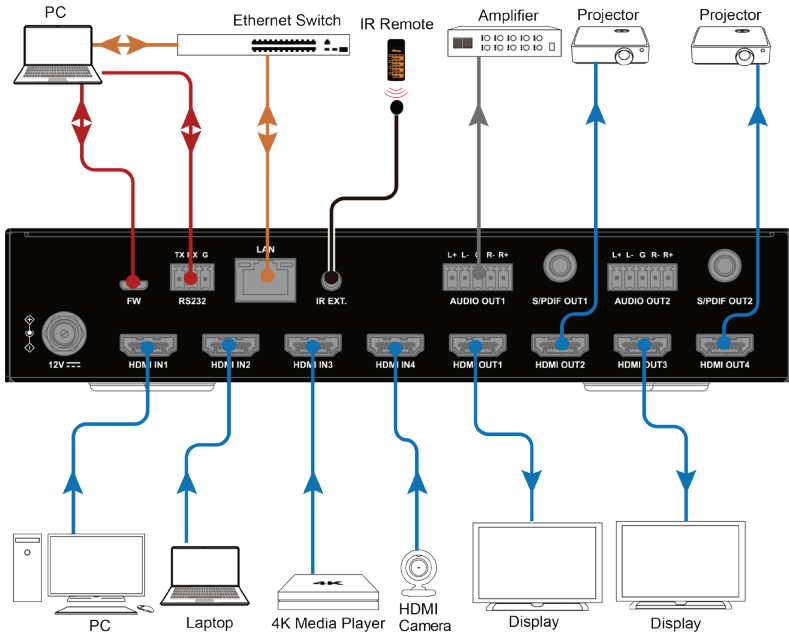

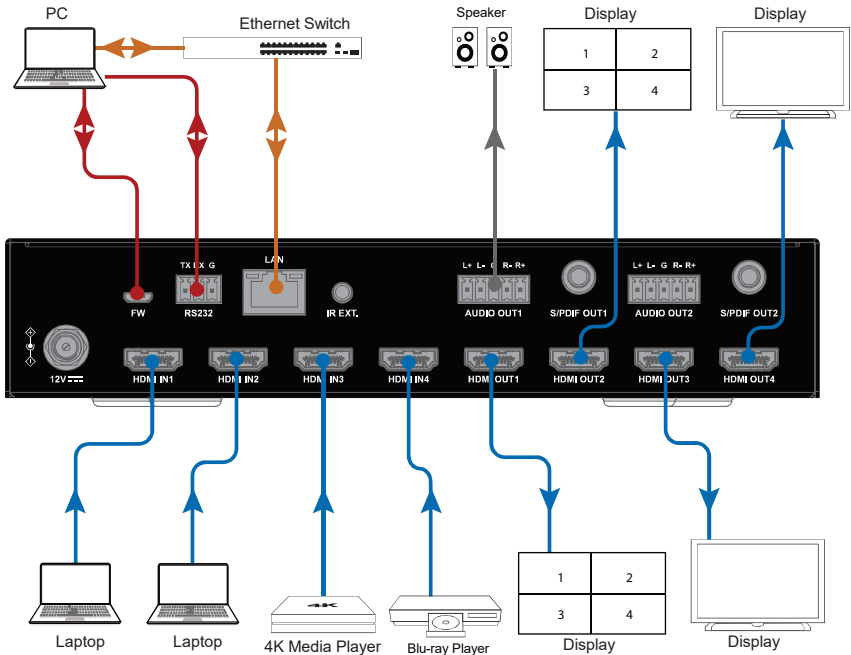

Multiview Mode



Note:

- Multiview output is mirrored in both HDMI output 1 and HDMI output 2, while HDMI output 3 and HDMI output 4 still support matrix switching.
- The audio source of multiple views can be set to any input source each window selected via API commands or web UI. Detail information, please refer to the separate document “[API Command Set_MV4X4-4KUHD](#)” or “[Web UI](#)” section.
- The matrix supports 5 layout modes, including Original, Dual view, PIP, Master and Quad, which can be select through API Commands or web UI. Detail information, please refer to the separate document “[API Command Set_MV4X4-4KHUHD](#)” or “[Web UI](#)” section.

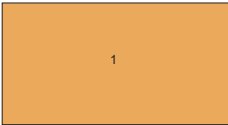
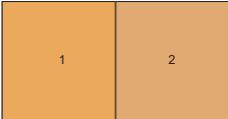
Layout Mode Introduction

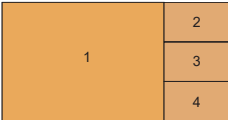
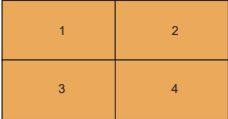
Graphic	Description
 <p style="text-align: center;">Original</p>	<p>Only one original input signal source without image processing is selected to be shown on the connected display. The input switching in this layout mode is same with matrix switcher mode.</p>
 <p style="text-align: center;">Dual view</p>	<p>Two input signals are selected simultaneously to be shown as two windows on the displays connected with HDMI output 1 and HDMI output 2.</p>
 <p style="text-align: center;">PIP</p>	<p>Two input signals are selected simultaneously to be shown as two windows on the displays connected with HDMI output 1 and HDMI output 2. The smaller window covers on the lower right corner above the larger one by default. The size (default: 1/16) and position (default: bottom right) of the smaller screen can be set through API commands or web UI.</p>
 <p style="text-align: center;">Master</p>	<p>The four HDMI input sources are shown as 4 windows simultaneously on the displays connected with HDMI output 1 and HDMI output 2. The master input can be selected from HDMI IN 1~4, and the slave screens are in same size.</p>
 <p style="text-align: center;">Quad</p>	<p>The four HDMI input sources are shown as 4 windows in same size simultaneously on the displays connected with HDMI output 1 and HDMI output 2.</p>

Videowall Mode

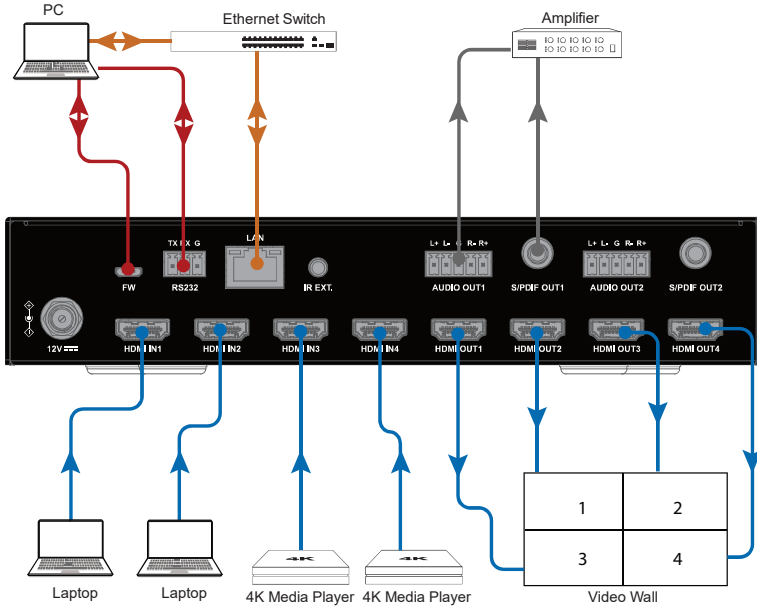

The matrix supports 2x2 videowall layout. Users can select any input as source of the videowall, set output distribution, set bezel correction and set 180° rotation of output image (to facilitate 2x2 videowall setup using TV display) through API commands or web UI. Detail information, please refer to the separate document “[API Command Set_MV4X4-4KUHD](#)” or “[Web UI](#)” section.

Button Control

Users can perform basic switching of input sources to output displays in matrix mode. For multiview and videowall control, it only supports web GUI control and API for configuration and control.

To select an input source for the output display:

1. Press one or multiple buttons of OUT 1-4 to select output port(s). The LED will light up once specific output port is selected.
2. Press one button of IN 1-4 to select an input port. The LED will light up one specific input port is selected.
3. Press the ENTER button to implement the selection. The selection takes effect when the LEDs are off.

IR Control

The device can be controlled by the IR remote controller in matrix switcher mode. Connect the IR receiver cable to the IR EXT. port at the rear panel of the device and ensure the receiver eye is accessible to the remote controller.

Note, due to complexity to configure and control, multiview and videowall only support web GUI and API configuration and control.

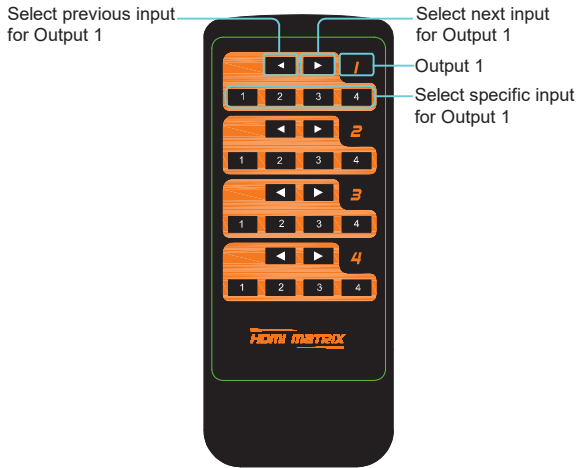

To select an input source for one output display:

1. Connect the IR receiver cable to the IR EXT. port at the rear panel of the device.
2. Select the target output display from the column 1-4.
3. Press the target input port number or previous (◀) / next (▶) button to select the desired input source.

Command Control

Advanced users may need to control the device via API commands. Two methods are provided for controlling this device through API commands:

1. RS232.

Connect a control PC to the RS232 port of the device. Before sending API commands to control the device, ensure the serial ports between this device and PC are configured correctly. A professional RS232 serial interface software (e.g., Serial Assist) may be needed as well.

Parameters	Default Value
Baud Rate	115200 bps
Data bits	8 bits
Parity	None
Stop bits	1 bit
Flow control	None

2. Telnet.

Connect a control PC to the LAN port of the device. Before you intend to control the device through telnet API, you shall establish connection between this device and your computer.

The form of the command for telnet connection is below:

telnet ip (port)

- *ip*: The device's IP address.
- *port*: The device's port number, this is non-required for some Telnet control tools. Default setting is 23.

For example, if the device's IP address is 192.168.11.143, the command for telnet connection shall be the following:

telnet 192.168.11.143

Obtain IP Address of the Device

To obtain the device's IP address:

1. Connect a control PC to the RS232 port of the device.
2. Configure RS232 parameters for the PC's serial port correctly through a RS232 serial port tool, such as Serial Assist.
3. Input the command `GET IPADDR<CR><LF>` and send. You will get a response with IP address, see following:

Input:

`GET IPADDR<CR><LF>`

Response:

IPADDR 172.16.18.173 MASK 255.255.255.0 GATEWAY 172.16.18.1

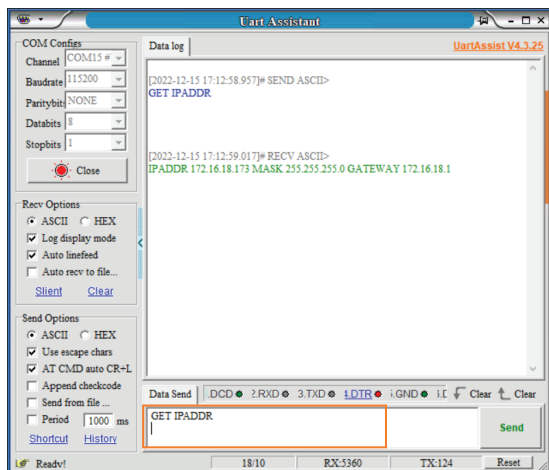

Note: When all is configured properly, you can control the device through commands, which are available in the separate document “*API Command Set_MV4X4-4KUHD*”.

Web UI

The Web UI designed for this device allows for basic controls and advanced settings. It can be accessed through a modern browser with latest version, e.g., Chrome, Safari, Firefox, IE10+, etc.

To get access the Web UI:

1. Connect the LAN port of the device to a local area network. (Ensure there’s a DHCP server in the network so that the device can obtain a valid IP address.)
2. Connect the PC to the same network as this device.
3. Input the device’s IP address in the browser and press Enter,

the following window will pop up. (Refer to [Obtain IP Address of the Device](#) section to get the device's IP address quickly).

4. The following window pops up. Input the password (default password: admin) and click **Login**.



The image shows a dialog box titled "Matrix Control Login". It contains a label "Password:" followed by a text input field. To the right of the input field is a blue button labeled "Login".

5. Input a new password in the dialog box and click **Apply** to enter the main page. The password shall be alphanumeric with 4 to 16 characters in length.

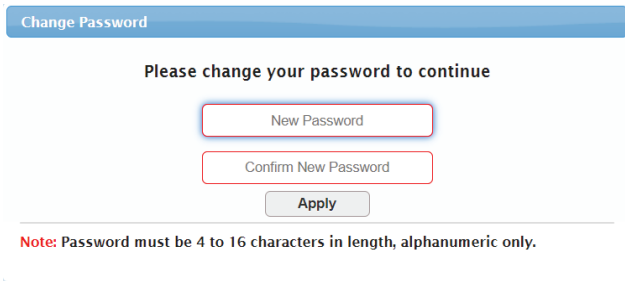

The image shows a dialog box titled "Change Password". It contains the text "Please change your password to continue". Below this text are two text input fields: "New Password" and "Confirm New Password". Below the input fields is a button labeled "Apply". At the bottom of the dialog box, there is a red note: "Note: Password must be 4 to 16 characters in length, alphanumeric only."

The main page consists of three tabs: Matrix Control, General Setting, Advanced Setting.

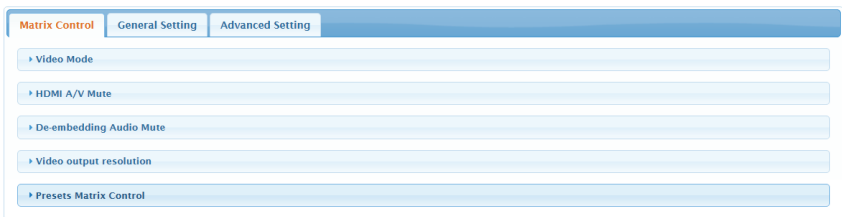

The image shows the main page settings menu. It has three tabs: "Matrix Control", "General Setting", and "Advanced Setting". The "Matrix Control" tab is selected. Below the tabs are five settings items, each with a right-pointing arrow:

- ▶ Video Mode
- ▶ HDMI A/V Mute
- ▶ De-embedding Audio Mute
- ▶ Video output resolution
- ▶ Presets Matrix Control

Matrix Control

Video Mode

1. Matrix switcher

The screenshot shows the 'Video Mode' interface with 'Matrix switcher' selected. It features a table for routing inputs to outputs and a legend for status indicators.

Zone\Source	INPUT 1	INPUT 2	INPUT 3	INPUT 4	CEC Control
OUTPUT 1	Working				On Off
OUTPUT 2		Working			On Off
OUTPUT 3			Working		On Off
OUTPUT 4				Working	On Off
ALL OUTPUTS					On Off

Legend: Working (Green), Error (Red)

When set the video mode to “Matrix switcher”, the device is used as a 4x4 matrix, this section manages distribution of input sources to output displays.

Click the button in the table to select the input for the output display (button turns from white to green once selection is done).

- **ALL OUTPUTS:** Click to route INPUT (n) for all OUTPUTS.

Default setting: Input 1 is routed to Output 1, ..., Input (n) is routed to Output (n), n = 1, 2, 3, 4.

- **CEC Control:**

⇒ **On:** Click to power on the display connected to the output selected through CEC.

⇒ **Off:** Click to power off the display connected to the output selected through CEC.

- **Video Details:** Click to view detailed information of input and output ports including status, resolution, framerate, etc., see following:

Video Details
✖

Input

Port 1 Refresh

Status
Connected

Frame Rate:
60

HDCP Version
NO HDCP

Signal
Valid

Color Space:
RGB

Resolution:
3840x2160

Color Depth:
8bit

Output

Port 1 Refresh

Status
Connected

Frame Rate:
60

HDCP Version
HDCP2.2

Signal
Valid

Color Space:
Ycbcr420

Resolution:
3840x2160

Color Depth:
8bit

2. Multi viewer

Video Mode

Matrix switcher
 Multi viewer
 Video wall

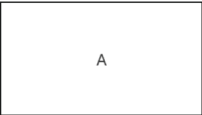

Original

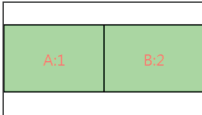

Dual View

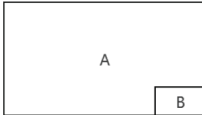

PIP

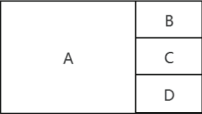

Master



Quad

Zone\Source	INPUT 1	INPUT 2	INPUT 3	INPUT 4	CEC Control
OUTPUT 1&OUTPUT 2-A					On Off
OUTPUT 1&OUTPUT 2-B					On Off
OUTPUT 3					On Off
OUTPUT 4					On Off

Image Stretch:

Window A: Normal Full

Window B: Normal Full

Audio: Window A

When set the video mode to “Multi viewer”, the output 1 and output 2 support multiple layout modes (Multiview output is mirrored displayed in both HDMI output 1 and HDMI output 2).

This section allows users to set layout mode among “Original”, “Dual View”, “PIP”, “Master” and “Quad”, select input source for each layout window and other configurations in different layout modes.

Default Setting: Dual View.

- **Dual View (Default):**

- ⇒ **OUTPUT 1 & OUTPUT 2-A/OUTPUT 1 & OUTPUT 2-B:**

Click the button in the table to select the input for the window A-1/ window B-2 of output 1 and output 2 (button turns from white to green once selection is done).

Default Setting: Input 1 is routed to Output 1 & Output 2-A, Input 2 is routed to Output 1 & Output 2-B.

- ⇒ **OUTPUT 3 & OUTPUT 4:** Click the button in the table to select the input for the output 3 and output 4 respectively (button turns from white to green once selection is done).

Default: Input 3 is routed to Output 3, and input 4 is routed to Output 4.

- ⇒ **CEC Control (On/Off):** Click to power on/off the display connected to the output selected through CEC.

Note: OUTPUT 1 and OUTPUT 2 display multiple windows mirrored, and can be powered on/off simultaneously through CEC.

- ⇒ **Image Stretch (Normal/Full):** By default, the image on the display is shown in normal aspect ratio in order to keep it undistorted. If users want to set one selected input's image to stretch to fill the entire screen, click “Full” to set. Users also can use the API command “SET VIDIN_STRETCH prm prm1<CR><LF>” to set it, please refer to the separate document “*API Command Set_MV4X4-4KUHD*”.

For example, in Dual view mode, by default, it is shown as figure 1, if users want to set window 1 to stretch full screen, click “Full” button below window 1 in web UI page or send command “SET VIDIN_STRETCH in1 origin <CR><LF>”, and input 1’ s image will be shown as figure 2.

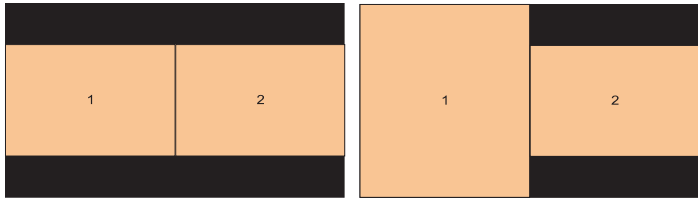

Figure 1

Figure 2

⇒ **Audio:** Select audio source for output 1 and output 2 from the dropdown menu.

Default Setting: window A, the audio is from the source window A selected.

Audio:

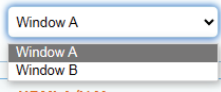

- **Original:**

Video Mode

Matrix switcher
 Multi viewer
 Video wall

Original
 Dual View
 PIP

Master
 Quad

Zone/Source	INPUT 1	INPUT 2	INPUT 3	INPUT 4	CEC Control
OUTPUT 1	<input checked="" type="checkbox"/>				<input type="checkbox"/> On <input type="checkbox"/> Off
OUTPUT 2		<input checked="" type="checkbox"/>			<input type="checkbox"/> On <input type="checkbox"/> Off
OUTPUT 3			<input checked="" type="checkbox"/>		<input type="checkbox"/> On <input type="checkbox"/> Off
OUTPUT 4				<input checked="" type="checkbox"/>	<input type="checkbox"/> On <input type="checkbox"/> Off

- ⇒ **OUTPUT 1/2/3/4:** Click the button in the table to select input source for output 1/2/3/4 respectively (button turns from white to green once selection is done).
Default Setting: Input 1 is routed to Output 1, ..., Input (n) is routed to Output (n), n = 1, 2, 3, 4.
- ⇒ **CEC Control (On/Off):** Click to power on/off the display connected to the output selected through CEC.

- **PIP**

The screenshot shows a video control interface with the following elements:

- Video Mode:** Radio buttons for Matrix switcher, Multi viewer (selected), and Video wall.
- Display Modes:**
 - Original: A single window labeled 'A'.
 - Dual View: Two windows labeled 'A' and 'B' side-by-side.
 - Master: A large window 'A' with three smaller windows 'B', 'C', and 'D' stacked vertically on the right.
 - Quad: Four windows labeled 'A', 'B', 'C', and 'D' in a 2x2 grid.
 - PIP: A large green window 'A.1' with a smaller green window 'B.2' in the bottom right corner.
- Routing Table:**

Zone\Source	INPUT 1	INPUT 2	INPUT 3	INPUT 4	CEC Control
OUTPUT 1&OUTPUT 2-A					On Off
OUTPUT 1&OUTPUT 2-B					On Off
OUTPUT 3					On Off
OUTPUT 4					On Off
- PIP Settings:**
 - PIP Position: Bottom Right
 - PIP Size: 1/16
 - Audio: Window A

- ⇒ **OUTPUT 1 & OUTPUT 2-A/OUTPUT 1 & OUTPUT 2-B:** Click the button in the table to select the input for the window A-1/ window B-2 of output 1 and output 2 (button turns from white to green once selection is done).
Default Setting: Input 1 is routed to Output 1 & Output 2-A, Input 2 is routed to Output 1 & Output 2-B.
- ⇒ **OUTPUT 3 & OUTPUT 4:** Click the button in the table to select the input for the output 3 and output 4

respectively (button turns from white to green once selection is done).

Default Setting: Input 3 is routed to Output 3, and Input 4 is routed to Output 4.

- ⇒ **CEC Control (On/Off):** Click to power on/off the display connected to the output selected through CEC.

Note: OUTPUT 1 and OUTPUT 2 display multiple windows mirrored, and can be powered on/off simultaneously through CEC.

- ⇒ **PIP Position:** Select the position of the window B-2 (small window) from the dropdown menu.

Default setting: Bottom Right

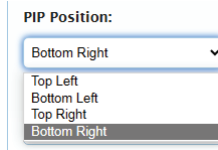

- ⇒ **PIP Size:** Select the ratio of the window B-2 (small window) to window A-1 (big window) from the dropdown menu. Default setting: 1/16

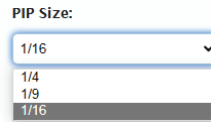

- ⇒ **Audio:** Select audio for output 1 and output 2 from the dropdown menu. Default setting: window A, the audio is from the source window A selected.

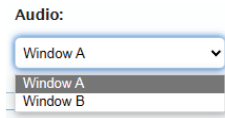

- **Master**

The screenshot shows a video control interface with the following elements:

- Video Mode:** Radio buttons for Matrix switcher, Multi viewer (selected), and Video wall.
- Display Modes:**
 - Original:** A single window labeled 'A'.
 - Dual View:** Two windows labeled 'A' and 'B' side-by-side.
 - PIP:** A large window 'A' with a smaller window 'B' overlaid in the bottom right corner.
 - Master:** A large green window 'A-1' with three smaller windows 'B-2', 'C-3', and 'D-4' stacked vertically on its right side.
 - Quad:** A 2x2 grid of windows labeled 'A', 'B', 'C', and 'D'.
- Routing Table:** A table with columns for Zone/Source, INPUT 1, INPUT 2, INPUT 3, INPUT 4, and CEC Control. Green cells indicate selected inputs.
- Audio:** A dropdown menu currently set to 'Window A'.

Zone/Source	INPUT 1	INPUT 2	INPUT 3	INPUT 4	CEC Control
OUTPUT 1&OUTPUT 2-A	Green				
OUTPUT 1&OUTPUT 2-B		Green			On Off
OUTPUT 1&OUTPUT 2-C			Green		On Off
OUTPUT 1&OUTPUT 2-D				Green	On Off
OUTPUT 3			Green		On Off
OUTPUT 4				Green	On Off

- ⇒ **OUTPUT 1 & OUTPUT 2-A /OUTPUT 1 & OUTPUT 2-B/ OUTPUT 1 & OUTPUT 2-D/ OUTPUT 1 & OUTPUT 2-D:** Click the button in the table to select the input for the window A-1/ window B-2/window C-3/window D-4 of output 1 and output 2 (button turns from white to green once selection is done).
Default Setting: Input 1 is routed to Output 1 & Output 2-A, Input 2 is routed to Output 1 & Output 2-B, Input 3 is routed to Output 1 & Output 2-C, and Input 4 is routed to Output 1 & Output 2-D.
- ⇒ **OUTPUT 3 & OUTPUT 4:** Click the button in the table to select the input for the output 3 and output 4 respectively (button turns from white to green once selection is done).
Default Setting: Input 3 is routed to Output 3, and Input 4 is routed to Output 4.
- ⇒ **CEC Control (On/Off):** Click to power on/off the display

connected to the output selected through CEC.

Note: OUTPUT 1 and OUTPUT 2 display multiple windows mirrored, and can be powered on/off simultaneously through CEC.

⇒ **Audio:** Select audio for output 1 and output 2 from the dropdown menu. Default setting: window A, the audio is from the source window A selected.

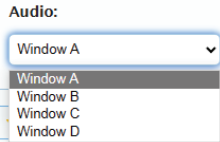

- **Quad**

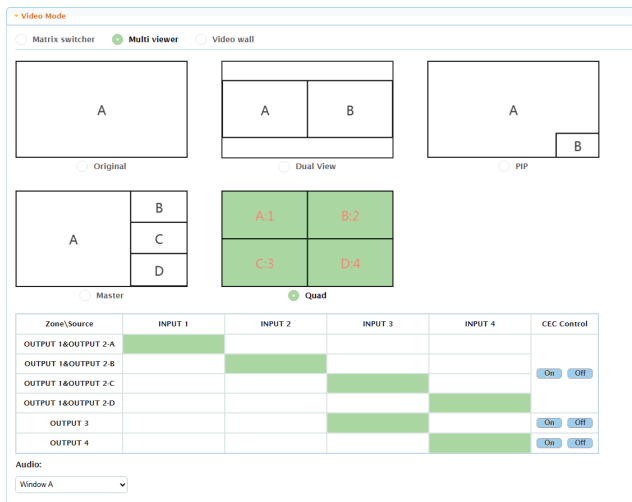

Zone/Source	INPUT 1	INPUT 2	INPUT 3	INPUT 4	CEC Control
OUTPUT 1&OUTPUT 2-A	Green				
OUTPUT 1&OUTPUT 2-B		Green			
OUTPUT 1&OUTPUT 2-C			Green		On Off
OUTPUT 1&OUTPUT 2-D				Green	On Off
OUTPUT 3			Green		On Off
OUTPUT 4				Green	On Off

⇒ **OUTPUT 1 & OUTPUT 2-A /OUTPUT 1 & OUTPUT 2-B/ OUTPUT 1 & OUTPUT 2-D/ OUTPUT 1 & OUTPUT 2-D:** Click the button in the table to select the input for the window A-1/ window B-2/window C-3/window D-4 of output 1 and output 2 (button turns from white to green once selection is done).

Default Setting: Input 1 is routed to Output 1 & Output 2-A, Input 2 is routed to Output 1 & Output 2-B, Input 3 is routed to Output 1 & Output 2-C, and Input 4 is routed to Output 1 & Output 2-D.

- ⇒ **OUTPUT 3 & OUTPUT 4:** Click the button in the table to select the input for the output 3 and output 4 respectively (button turns from white to green once selection is done).

Default Setting: Input 3 is routed to Output 3, and Input 4 is routed to Output 4.

- ⇒ **CEC Control (On/Off):** Click to power on/off the display connected to the output selected through CEC.

Note: OUTPUT 1 and OUTPUT 2 display multiple windows mirrored, and can be powered on/off simultaneously through CEC.

- ⇒ **Audio:** Select audio for output 1 and output 2 from the dropdown menu. Default Setting: window A, the audio is from the source window A selected.

3. Videowall

The screenshot shows a software interface for configuring a videowall. It includes several sections:

- Mode Selection:** Radio buttons for Matrix switcher, Multi viewer, and Video wall (selected).
- Video wall layout:** A 2x2 grid with buttons for OUTPUT 1, OUTPUT 2, OUTPUT 3, and OUTPUT 4. The '2x2' layout is selected.
- Video wall outputs:** A table mapping window positions to outputs.

	OUTPUT 1	OUTPUT 2	OUTPUT 3	OUTPUT 4
Top Left	Green			
Top Right		Green		
Bottom Left			Green	
Bottom Right				Green
- Video wall input:** A table mapping sources to inputs.

	INPUT 1	INPUT 2	INPUT 3	INPUT 4
Source	Green			
- Bezel Adjustment:** Input fields for VW, OW, VH, and OH, with an Apply button.
- Diagram:** A schematic showing a window (VW) within a bezel (OW) on a display of height (OH) and width (VH). UNIT: 1mm.
- Video wall flip:** Radio buttons for OUTPUT 1, OUTPUT 2, OUTPUT 3, and OUTPUT 4.

When set the video to “Videowall” mode, users can set videowall outputs distribution, select input source, set bezel correction and set videowall image rotation.

- **Videowall layout:** Shows the videowall layout is 2x2.
- **Videowall outputs:** Click the button in the table to set the positions of the outputs in videowall (button turns from white to green once selection is done).

Default Setting:

OUTPUT 1: Top Left;

OUTPUT 2: Top Right;

OUTPUT 3: Bottom Left;

OUTPUT 4: Bottom Right.

- **Videowall input:** Click the button in the table to select input source for the videowall (button turns from white to green once selection is done).

Default Setting: INPUT 1

- **Videowall flip:** Click the check box before the output 1-4 to set the corresponding image to be rotated 180°.

Default setting: unchecked.

- **Bezel Adjustment:** Set bezel compensation, so that there is no position deviation of image from each screen in the videowall.

Default settings: 0; Range: 0-10000

⇒ **OW/OH:** These are the outside width/height of each videowall display.

⇒ **VW/VH:** These are the inner width/height of each videowall display.

⇒ **Apply:** Click to apply the bezel correction settings.

Note: To ensure proper visual display, all videowall displays are recommended to be same size.

HDMI A/V Mute

▼ HDMI A/V Mute

OUTPUT 1 OFF

OUTPUT 2 OFF

OUTPUT 3 OFF

OUTPUT 4 OFF

- **ON:** Select to mute video and audio for selected HDMI output port.
 - **OFF:** Select to unmute video and audio for selected HDMI output port.
- Default setting: OFF

De-embedded Audio Mute

▼ De-embedding Audio Mute

OUTPUT 1 OFF

OUTPUT 2 OFF

- **ON:** Select to mute de-embedded audio for selected audio output ports.
 - **OFF:** Select to unmute de-embedded audio for selected audio output ports.
- Default setting: OFF

Video output resolution

▼ Video output resolution

Output 1

Auto Manual Bypass

Resolution

0x0@0

This section manages resolution configurations for Output 1-4. Three operation options are provided for each output.

- **Auto:** Select to automatically adapt to display EDID and resolution. E.g., If the display supports up to 4K@30Hz, the device will output signal with 4K@30Hz.

- **Manual:** Select a desired output resolution from the Resolution dropdown menu for the selected output port.
- **Bypass:** Select to bypass the input video source to the selected output port. When “Bypass” is selected, black screen may occur on the display if unsupported resolutions are switched to the display.

Default: Auto

Note:

- In Matrix switcher mode, “Auto” and “Manual” options are available for all output ports (1 to 4), while “Bypass” is available for Output 1 and Output 2 only.
- In Multiview mode, when select original layout mode, “Auto” and “Manual” options are available for all output ports (1 to 4), while “Bypass” is available for Output 1 and Output 2 only. When select other layout modes, “Auto” and “Manual” options are available for Output 1 and Output 2, while “Bypass” is available for Output 3 and Output 4 only.

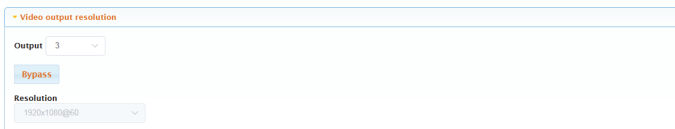
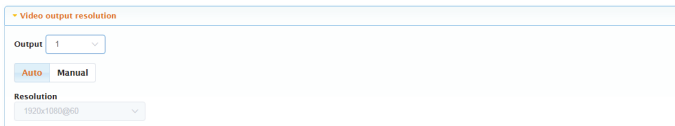

- In Videowall mode, “Auto” and “Manual” options are available for all output ports (1 to 4).

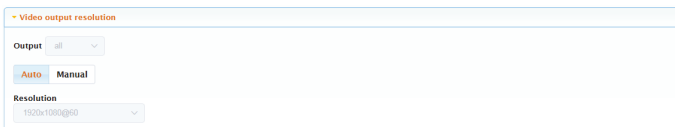

Presets Matrix Control

Presets Matrix Control

Preset 1

Preset 2

Preset 3

This section saves or loads the settings of or to Video Matrix Control section.

- **Save:** Click to save settings of Video Matrix Control section.
- **Load:** Click to load settings to Video Matrix Control section.

To save a setting of Video Matrix to Preset 1:

1. Complete the input and output routing in Video Matrix Control section.
2. Click “Save” in “Preset 1”. Then the “Preset 1” is saved successfully.

General Setting

Source Naming

Source Naming

Input 1

Input 2

Input 3

Input 4

Note: The length of alias name is limited to 15 characters total.

This section allows you to change to new input ports’ names.

- **Save:** Click to save and apply all changes.
- **Reset:** Click to reset all changes.

Note: The length of each new name shall not exceed 15 characters.

Zone Naming

Zone Naming

Output 1 Output 2 Output 3

Output 4

Note: The length of alias name is limited to 15 characters total.

This section allows you to change to new output ports' names.

- **Save:** Click to save and apply all changes.
- **Reset:** Click to reset all changes.

Note: The length of each new name shall not exceed 15 characters.

Advanced Setting

Lower Power Mode

Low Power Mode

Standby: ON OFF

This section provides setting of Lower Power Mode. In Low Power Mode, the device will shut down all video outputs and enter standby status.

- **ON:** Select to turn on Lower Power Mode to make the device enter standby status.

Note: When on is selected, the web UI page will log out, you need to re-login to enter the main page.

- **OFF:** Select to turn off Lower Power Mode to make the device work properly.

Default setting: OFF

EDID Preset

EDID Preset			
Input	Preset	Input	Preset
INPUT 1	<input type="text" value="4K60 2.0CH PCM Audio with SDR"/>	INPUT 2	<input type="text" value="4K60 2.0CH PCM Audio with SDR"/>
INPUT 3	<input type="text" value="4K60 2.0CH PCM Audio with SDR"/>	INPUT 4	<input type="text" value="4K60 2.0CH PCM Audio with SDR"/>

This section allows you to configure EDID setting for each input port. Available EDID options are provided from the dropdown menu, click to select a desired option.

- Copy From Output 1
- Copy From Output 2
- Copy From Output 3
- Copy From Output 4
- 4K60 2.0CH PCM Audio with HDR
- 4K60 2.0CH PCM Audio with SDR (Default)
- 4K30 2.0CH PCM Audio with HDR
- 4K30 2.0CH PCM Audio with SDR
- 1080p@60Hz 2.0CH PCM Audio with HDR
- 1080p@60Hz 2.0CH PCM Audio with SDR
- EDID Write

EDID Read

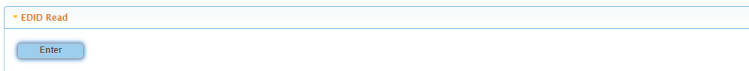

A dialog box titled "EDID Read" with a blue border. Inside, there is a light blue button labeled "Enter".

Click Enter to enter EDID Setting page, select the desired HDMI output and click to “Read” its EDID information.

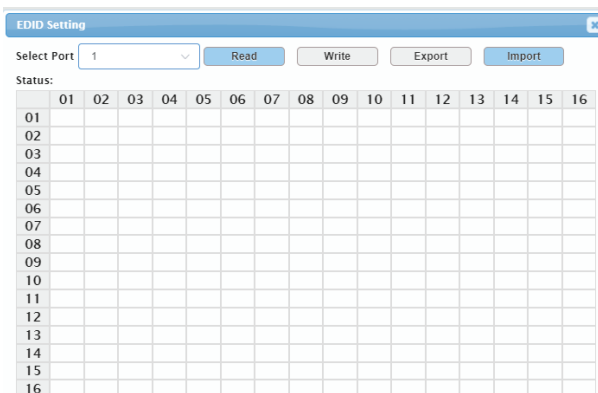

The "EDID Setting" window features a title bar with a close button. Below the title bar, there is a "Select Port" dropdown menu currently set to "1". To the right of the dropdown are four buttons: "Read" (highlighted in blue), "Write", "Export", and "Import". Below these buttons, the text "Status:" is displayed. The main area of the window is a grid with 16 columns labeled 01 through 16 and 16 rows labeled 01 through 16. All cells in the grid are currently empty.

- **Read:** Click to read the selected output port's EDID

information.

- **Write:** Click to write EDID information to the selected input port.
- **Export:** Click to export EDID file to your local computer.
- **Import:** Click to import EDID file from your local computer.

CEC Control

Output	Manual		Auto	
	Display On	Display Off	On/Off	Delay Time(1~30min)
OUTPUT 1	<input type="button" value="Display On"/>	<input type="button" value="Display Off"/>	<input type="checkbox"/>	2
OUTPUT 2	<input type="button" value="Display On"/>	<input type="button" value="Display Off"/>	<input type="checkbox"/>	2
OUTPUT 3	<input type="button" value="Display On"/>	<input type="button" value="Display Off"/>	<input type="checkbox"/>	2
OUTPUT 4	<input type="button" value="Display On"/>	<input type="button" value="Display Off"/>	<input type="checkbox"/>	2

- **Display On:** Click to power on the display connected to the output selected.
- **Display Off:** Click to power off the display connected to the output selected.
- **Auto On/Off:** Select to enable or disable CEC Auto Control. Default setting: Off
- **Auto Delay Time (1~30min):** Click the up/down arrow to set the time for the display to power off automatically when no signal is present. For example, if the time is set to 2 minutes, the output display will power off automatically when there's no signal at the display for 2 minutes.

HDCP

HDCP		
INPUT 1	<input type="checkbox"/>	
INPUT 2	<input type="checkbox"/>	
INPUT 3	<input type="checkbox"/>	
INPUT 4	<input type="checkbox"/>	

This section allows you to enable or disable HDCP encryption of each input port.

- **ON:** Select to enable HDCP encryption for the selected input

port.

- **OFF:** Select to disable HDCP encryption for the selected input port.

Default setting: ON

Change Login Password

Change Login Password

Old Password

New Password

Confirm New Password

Note: Password must be 4 to 16 characters in length, alphanumeric only.

Save

This section is to change login password.

Default setting: admin

Note: Password must be 4 to 16 characters in length, alphanumeric only.

Network

Network

IP Type

IP Address

Subnet Mask

Default Gateway

Save

This section is to set between the static and dynamic IP address.

- IP Type:
 - ⇒ **DHCP:** When enabled, the IP address of the Matrix is assigned automatically by the DHCP server connected.
 - ⇒ **Static:** When enabled, you need to set up the IP address manually.

Default setting: DHCP

- **Save:** Click to save and perform the network setting, and the setting change will take effect immediately.

Note:

- When "Static" is selected, please ensure your PC is in the same network segment as the device.

Custom Web UI Logo

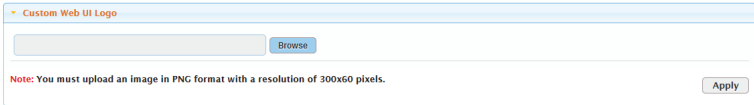

Custom Web UI Logo

Note: You must upload an image in PNG format with a resolution of 300x60 pixels.

This section allows you to create your own logo for the Web UI. To create customized Web UI logo: click “Browse” for the new logo file, and choose “Apply”.

Note: The new logo used should be in PNG format and less than 300x60 pixels.

System Version

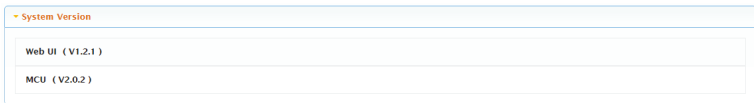

System Version

Web UI (V1.2.1)
MCU (V2.0.2)

This section provides Web UI and MCU version information.

FW Update

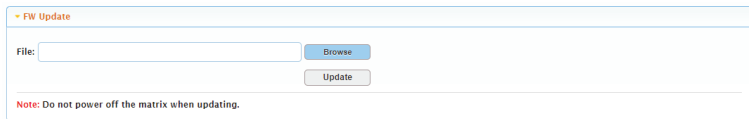

FW Update

File:

Note: Do not power off the matrix when updating.

To update device’s firmware:

1. Click “Browse” for the update file.

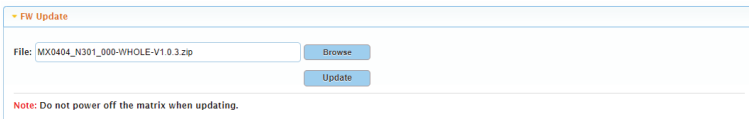

FW Update

File:

Note: Do not power off the matrix when updating.

2. Click “Update” to perform upgrade. The update will be

completed when the progress bar reaches 100%.

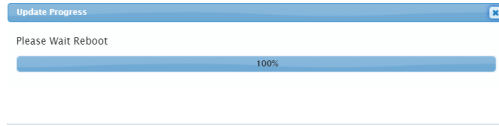

Note:

- The device will reboot automatically when firmware update is completed successfully. Please wait for about 2-3 minutes, then refresh and log in again.
- DO NOT power off the device during the updating process.

System

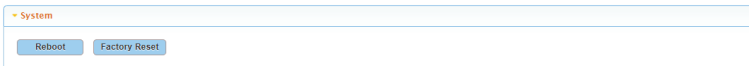

- **Reboot:** Click to reboot device.
- **Factory Reset:** Click to reset the device to factory default.

Log

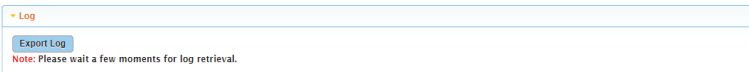

This section displays system setting change records. Click “Export Log” to download the log to your local computer.

Firmware Upgrade

The device supports firmware upgrade through web UI and micro-USB port on rear panel.

To upgrade firmware through Web UI, see [FW Update](#) section.

To upgrade firmware through micro-USB port, perform the following:

1. Download the upgrade file on your local PC.
2. Connect the device's micro-USB port to your PC. Send the command **UPG UFU<CR><LF>** to the device using a RS232 serial tool.
3. Open the upgrade file folder and launch the **USBDownloadTool2.1.exe** software.

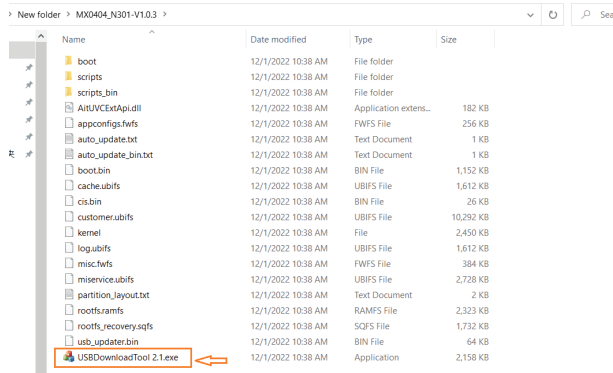

4. Click “Upgrade Firmware” to start upgrade. A window will pop up, indicating that firmware is completed successfully.

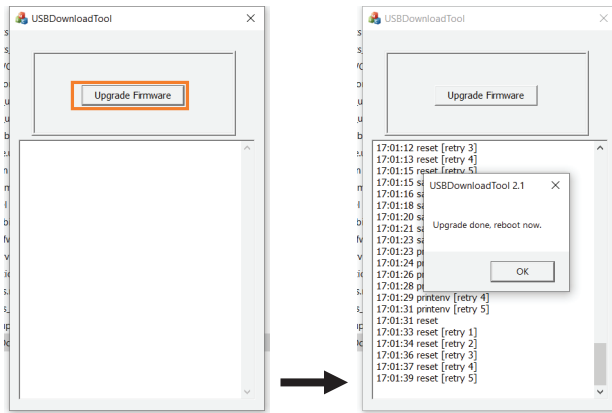

When the upgrade process is completed, the device will reboot.

Note:

- Do not cut off the power during the upgrade process.

Warranty

All LINK products come with a 2-year limited liability warranty. This warranty includes parts and labor repairs on all components found to be defective in material or workmanship under normal conditions of use. This warranty shall not apply to products which have been abused, modified, or disassembled. Warranty items only by authorized resellers. Warranty not eligible for products purchased through non-authorized online sellers.

A product that fails under conditions other than those covered will be repaired at the current price of parts and labor in effect at the time of repair. Such repairs are warranted for 90 days from the date of reshipment to the buyer. If the unit is delivered by mail, customers agree to insure the unit or assume the risk of loss or damage in transit. Under no circumstances will a unit be accepted without a return authorization number. The warranty is in lieu of all other warranties expressed or implied, including without limitations, any other implied warranty or fitness or merchantability for any particular purpose, all of which are expressly disclaimed. Proof of sale may be required in order to claim warranty.

LINK

MSTR

WWW.MSTRBRAND.COM