

UN 5.0-Gallon Round Solid Packaging with EZ Cover®

Multiple Uses

Solid Hazardous Materials
 Solid Packaging (1H2)
 Packing Group II or III (Y)
 Gross mass rating of 27 kg. / 59.5 lbs.

Product Codes

Container: **U059**
 Description: 5.0-gallon round can
 Cover: **LTGZ**
 Description: Tamper-evident, EZ Cover
 with four tabs and tubular gasket

Features

Gauge: 90 mil.
 Nominal capacity: 5.0 USG / 19.0L
 Stack performance: 400 lbs.*
 Tare weights: Body: 2.12 lbs. / .96 kgs.
 Cover: .60 lbs. / .27 kgs.

*Note: *Ratings will be reduced with uneven load distribution.*

Specifications with Cover

Dimensions: 12-3/8"D. X 14-7/8"H
 Maximum capacity: 5.6 USG / 21 L
 Tare weight: 2.72 lbs. / 1.23 kgs.*

*Note: *With handle, add .10 lbs.*

Colors

Standard: White, Black and Natural
 Custom: Available at manufacturer's discretion

Decorating Options

Silk - Screening: 32"W X 8-3/4"H
 Four or six* color offset printing
 Print area: 34"L X 9-1/4"H
 Sleeve or pressure sensitive labeling

*Notes: *Where available*

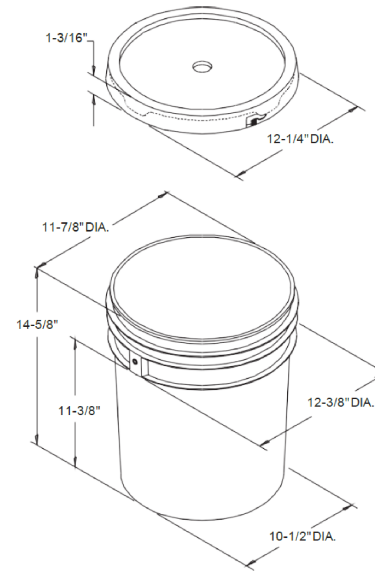

Shipping Data

	Bodies	Covers*
Qty. per pallet/carton:	144	1152 (24 boxes of 48)
Gross Weight (lbs./kgs.)**:	305.3/138.5	691.2/311
Den. (lbs./C.F./kgs./m3):	5.9/95.5	6.2/98.1
Length (in./cm.):	49.3/125.2	51/129.5
Width (in./cm.):	37.5/95.3	40/101.6
Height (in./cm.):	49.5/127.7	95/241.3

Filled Containers

36 (12 per layer / 3 layers high)
 Pallet height: 48.8"

Full truckload quantity of 6,336 bodies and covers***

*Notes: *Bulk pack of 288 also available
 **Weight does not include pallet/packaging
 ***Truckload quantity based on 53' trailer*

Materials

FDA approved materials
 Resin: Body: High-Density Polyethylene (HDPE)
 Cover: High-Density Polyethylene (HDPE) with
 Ethylene Propylene Diene Monomer (EPDM) Gasket

Optional Carrying Handles

Plastic HDPE or
 Metal nine-gauge gal. steel

DISCLAIMER

THIS INFORMATION IS PROVIDED AS A GENERAL GUIDE, INCLUDING DIMENSIONS. IT IS THE CUSTOMER'S RESPONSIBILITIES TO SELECT THE PROPER CONTAINER FOR PRODUCT AND APPLICATION COMPATIBILITY.

DISTRIBUTED BY:



REF NO.:

DWG10142

DESCRIPTION:

5 gallon HDPE Open Head Pail