

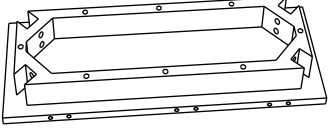







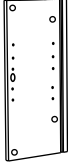

ASSEMBLY INSTRUCTIONS

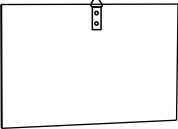
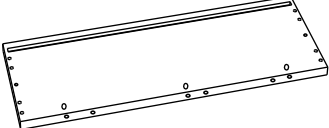
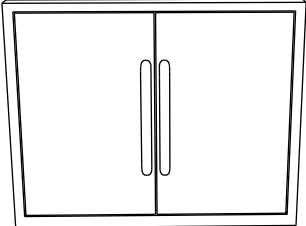
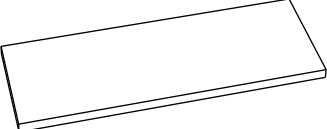
McCutcheon Free- Standing Accent Floor Cabinet





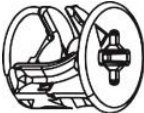

PART LIST :-

NO.	DESCRIPTION	IMAGE	QTY
A	BOTTOM		1
B	LEGS		4
C	LEFT SIDE PANNEL		1
D	RIGHT SIDE PANNEL		1
E	BACK		1
F	TOP		1
G	FRAME WITH PRE-ATTACHED DOOR		1
H	ADJUSTABLE SHELF		1

HARDWARE LIST :-

NO.	DESCRIPTION	IMAGE	QTY
I	ALLEN SCREWS	 M6X50	8
J	WASHER	 M6x16	8
K	DOWEL	 8x40mm	24
L	MINIFIX	 10x40mm	18
M	CAMLOCK	 12x15mm	18
N	SHELF PIN	 5X18mm	4
O	ALLEN KEY		1

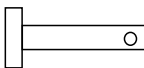
ANTI TIP KIT LIST :-

P	ANCHOR	 4X35mm	2
Q	D - RING	 20X50mm	1
R	SCREW	 4X35mm	2
S	WIRE	 12X270mm	1
T	RIVIT	 10X25mm	1
U	PIN	 8X30mm	1

STEP:- 1

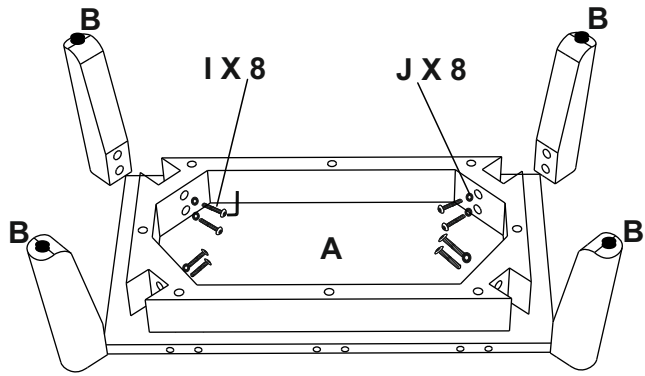

STEP:- 2

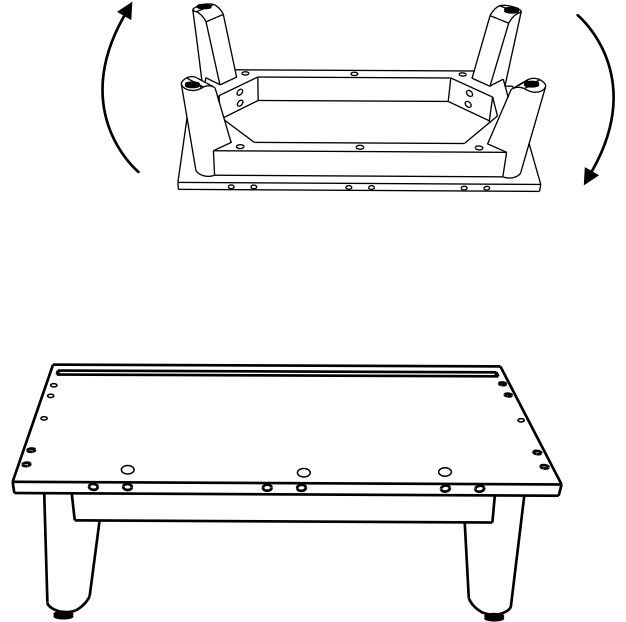

STEP:- 3

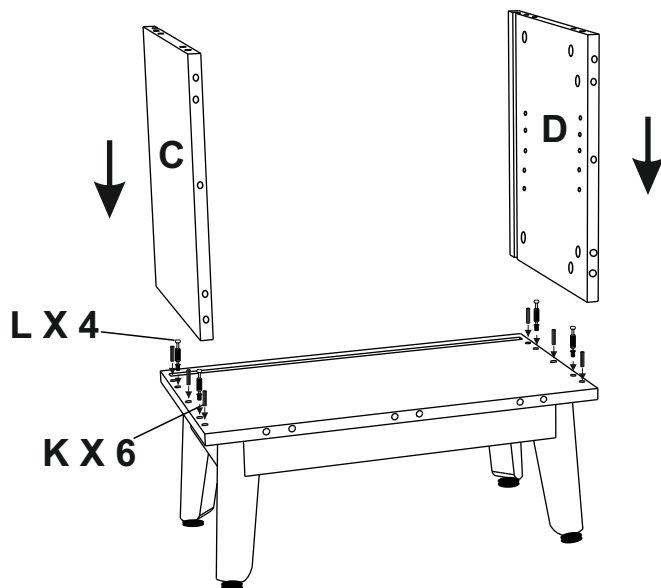

STEP:- 4

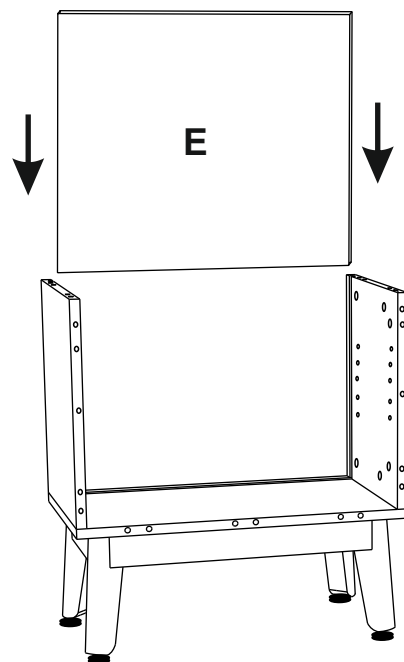

STEP:- 5

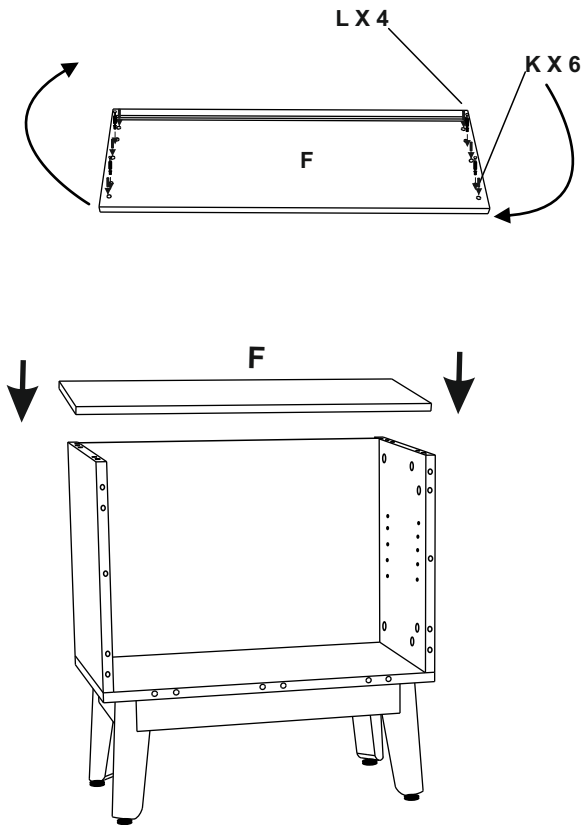

STEP:- 6

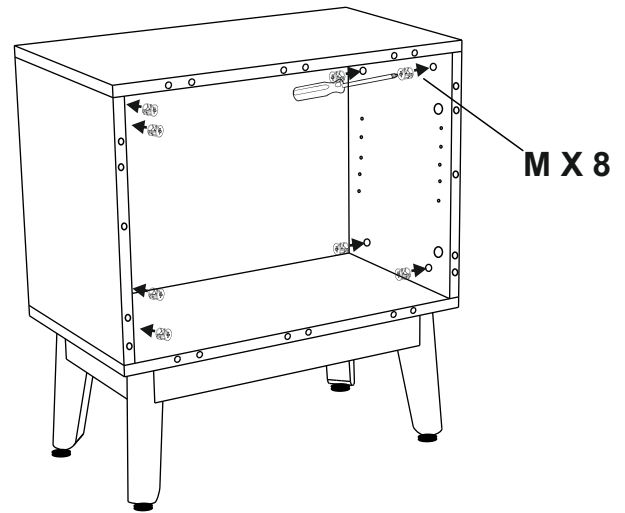

STEP:- 7

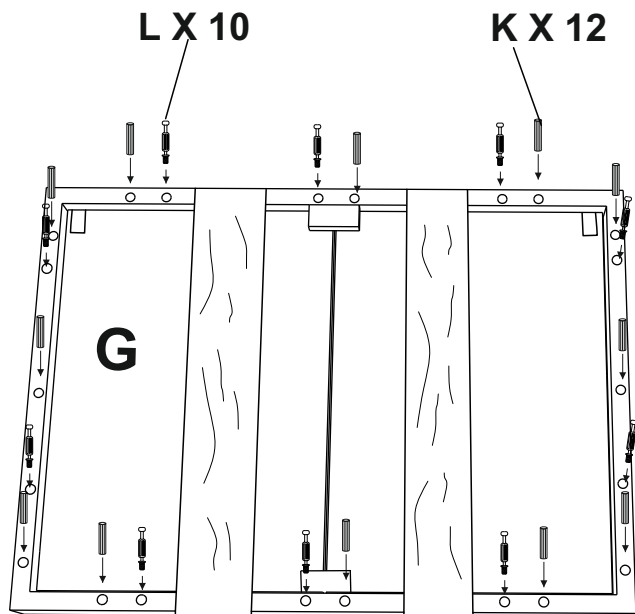

STEP:- 8

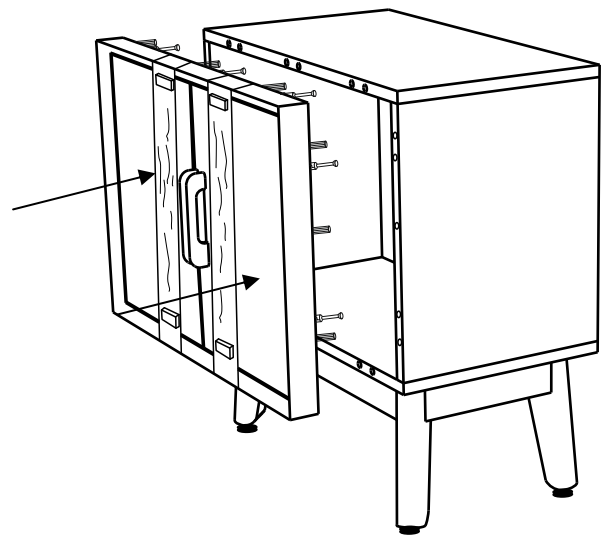

STEP:- 9

Use Paper Cutter for removing shrink wrap before final door assmebly.

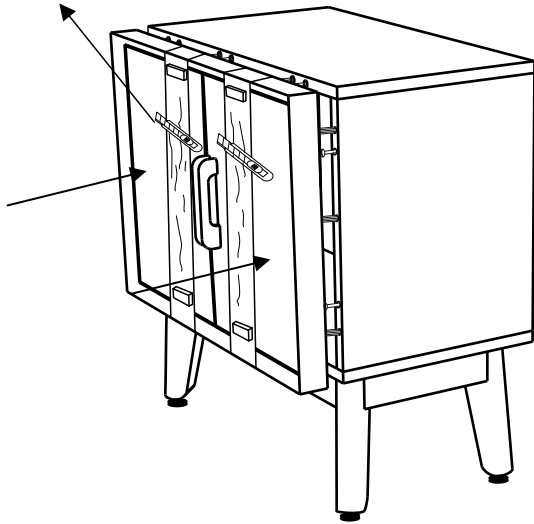

STEP:- 10

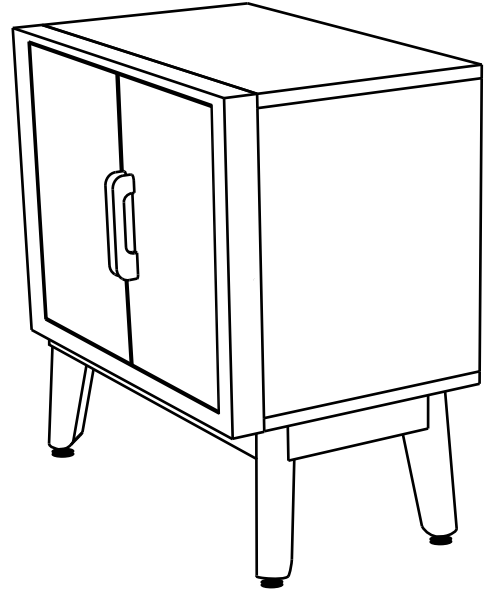

STEP:- 11

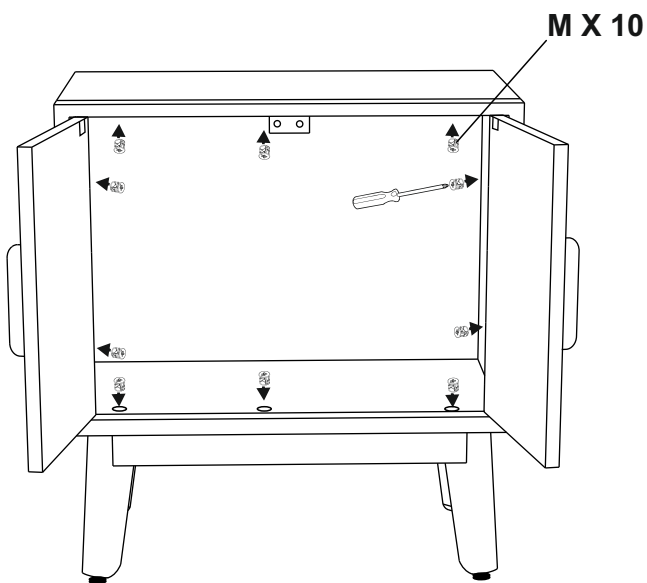

STEP:- 12

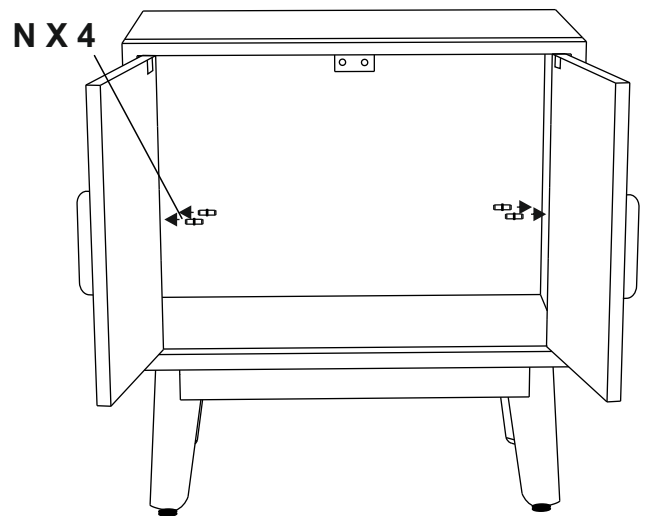

STEP:- 13

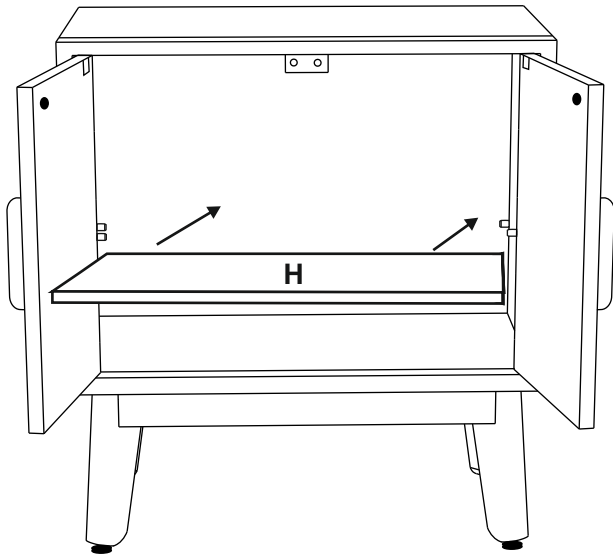

STEP:- 14

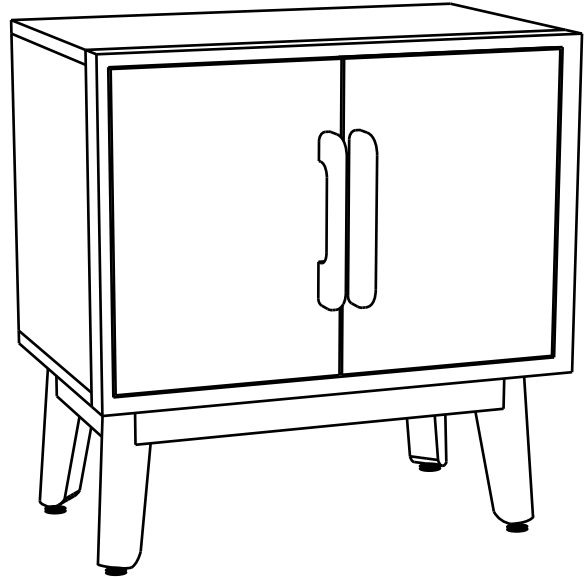

STEP:- 15

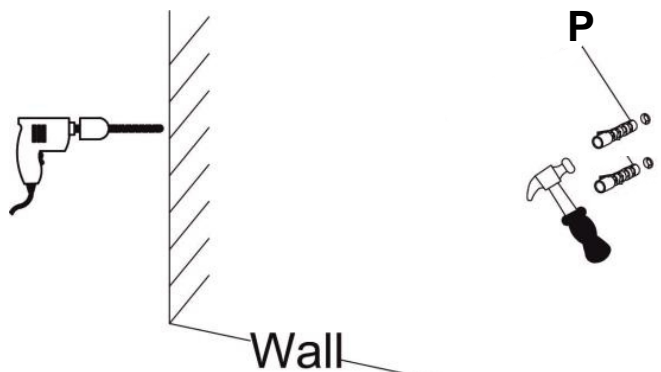

If installing item into a wall stud, do not use wall anchors.

If installing item into drywall use instructions below:

1. Predrill a 1/16" hole in anchor locations to verify no stud is present.
2. If no stud is present, predrill a hole in the drywall slightly smaller than the body (long portion that is inserted in the wall) of the wall anchor.
3. Using a light hammer, gently tap the wall anchor into place until the ridge of the wall anchor is touching the drywall.
4. Using a hand screwdriver, set the screw into the wall anchor the appropriate distance away from the wall to allow the product hanger to rest securely on the screw.

Si vous installez l'article dans un poteau mural, n'utilisez pas des dispositifs d'ancrage au mur.

Si vous installez l'article dans une cloison sèche, utilisez les directives ci-dessous:

1. Pré-percez un trou de 1,6 mm à l'emplacement des dispositifs d'ancrage pour vérifier l'absence de poteau mural.
2. Le cas échéant, pré-percez dans la cloison sèche un trou qui est légèrement plus petit que le corps (partie longue qui est insérée dans le mur) du dispositif d'ancrage.
3. Au moyen d'un marteau léger, tapez doucement le dispositif d'ancrage au mur en place jusqu'à ce que sa crête touche à la cloison sèche.
4. Au moyen d'un tournevis manuel, placez la vis dans le dispositif d'ancrage au mur à la distance appropriée du mur pour permettre au support du produit de s'appuyer solidement sur la vis.

Si instala el artículo en un montante de pared, no use tacos de anclaje.

Si instala el artículo en un panel de yeso, siga las siguientes instrucciones:

1. Con un taladro, haga un orificio de 1.5 mm en las ubicaciones de los andajes para verificar que no haya montantes.
2. Si no hay montantes, haga un orificio en la pared de yeso que sea levemente más pequeño que el cuerpo (parte más larga que se inserta en la pared) del anclaje, utilizando un taladro.
3. Con un martillo liviano, golpee suavemente el anclaje de pared en su lugar hasta que la cresta toque la pared de yeso.
4. Con un destornillador manual, coloque el tornillo en el anclaje a una distancia adecuada de la pared para permitir que el soporte del producto repose de manera segura sobre el tornillo.

7 CSS5541 1 _

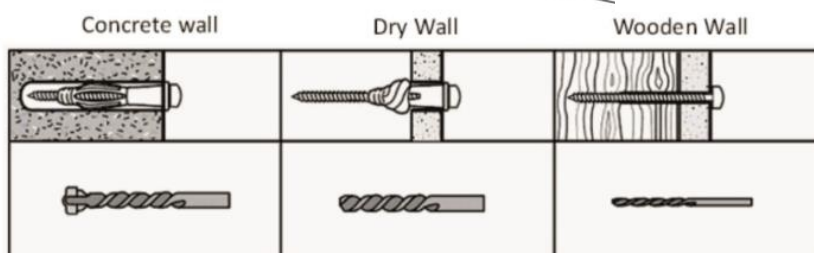

STEP:- 16

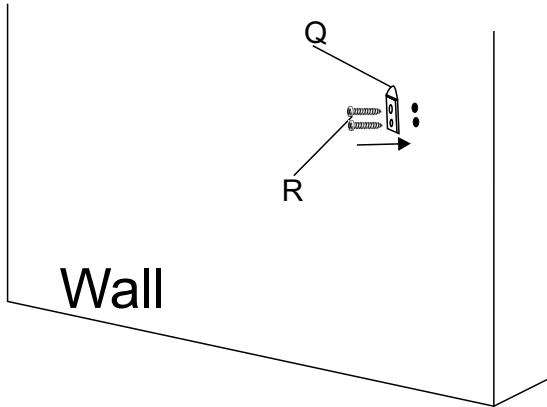

STEP:- 17

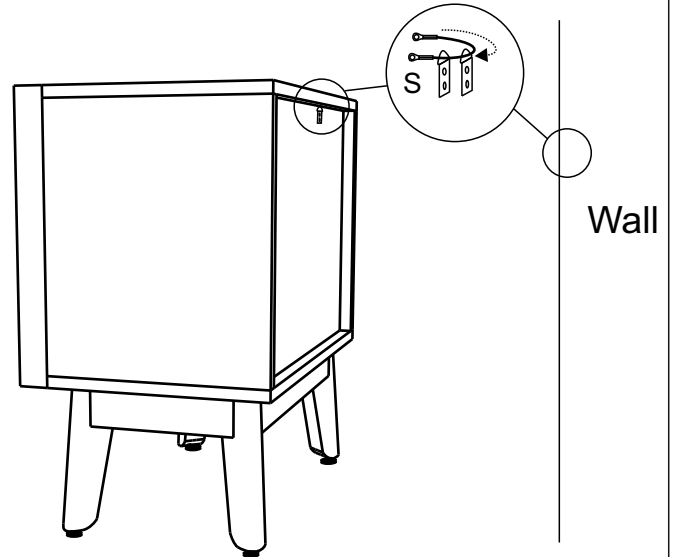

STEP:- 18

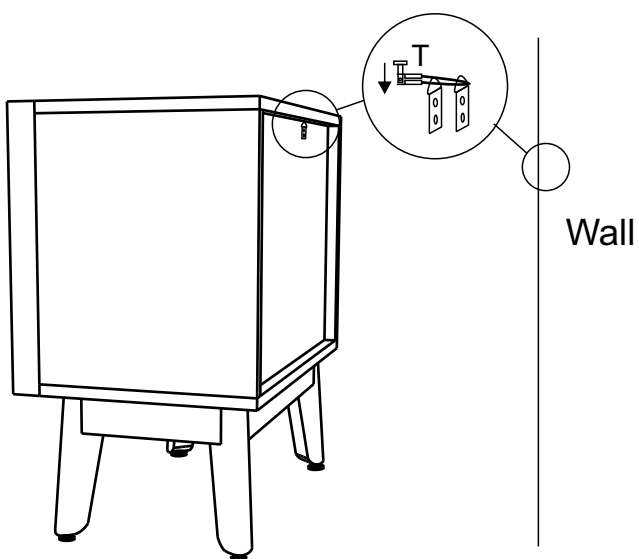

STEP:- 19

