



# Straight Line, Side Opening Deadend Clamps



## Aluminum Straight Line, Side Opening Deadend Clamps

Connects primary conductor to deadend insulator

### Features

- U-Bolts are captive
- Spring loaded side opening - shipped in open position
- Tin plated for copper conductor (add suffix "-TP")

### Material

Body and Keeper: Aluminum Alloy A356-T6  
 Cotter Pin and Compression Spring: Stainless steel  
 Hardware: Steel hot dip galvanized ASTM A-153

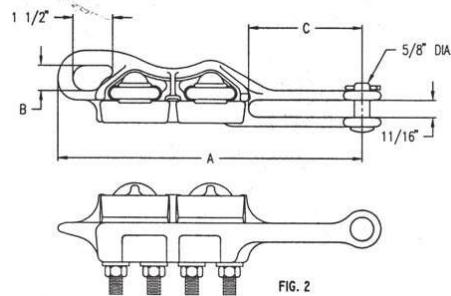
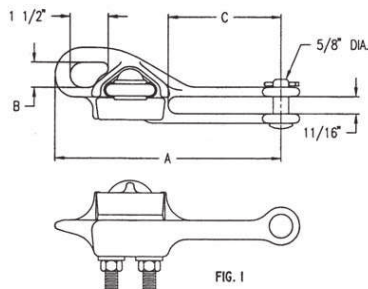

Catalog Number	Conductor Range			U-Bolts		Dimensions			Ultimate Strength		Weight /100 (lbs)
	Inches	ACSR	Aluminum	No	Size	A	B	C	Body	Sag Eye	
ASO-398-1-N	0.198 - 0.447	#6 - 2/0	#4 - 2/0	1	3/8	7.78	3.56	1.06	6000	6000	116
ASO-570-1-N	0.198 - 0.570	#6 - 4/0	#4 - 4/0	1	1/2	8.63	3.75	1.06	8000	8000	160
ASO-684-1-N	0.250 - 0.684	#4 - 336.4	#2 - 350	1	1/2	9.13	4.25	1.06	8000	8000	191
ASO-684-2-N	0.250 - 0.684	#4 - 336.4	#2 - 350	2	1/2	12.22	4.25	1.06	8000	8000	277
ASO-858-1-N	0.250 - 0.880	#4 - 556.5	#2 - 556.6	1	1/2	9.84	4.81	1.06	8000	5000	208
ASO-858-2-N	0.502 - 0.880	3/0 - 556.5	4/0 - 556.5	2	1/2	13.50	5.00	1.06	12000	9000	393
ASO-1160-2-N	0.684 - 1.160	336.4 - 900	397.5 - 954	2	1/2	15.88	7.00	1.06	12000	9000	450
ASO-1259-2-N	0.666 - 1.263	336.4 - 1113	336.4 - 1200	2	1/2	15.50	6.75	1.06	15000	11250	610

### Notes:

- 1) Suffix "-N" indicates no fitting
- 2) Replace "-N" with suffix "-S" for socket fitting
- 3) Replace "-N" with suffix "-C" for clevis fitting
- 4) Add suffix "-HP" for hex clevis pin fitting
- 5) Add suffix "-E" for lifting eye on keeper fitting
- 6) Add suffix "-TP" for tin plating
- 7) Recommended torque on U-Bolts: 3/8" - 20-25 ft/lbs; 1/2" - 40-45 ft/lbs

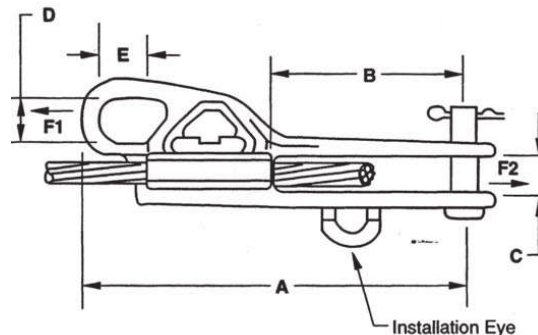

Catalog Number	Conductor Range			U-Bolts		Dimensions			Ultimate Strength		Weight /100 (lbs)
	Inches	ACSR	Aluminum	No	Size	A	B	C	Body	Sag Eye	
HCDS51-SO	0.190 - 0.510	#6 - 3/0	#4 - 4/0	1	1/2	8.00	3.81	0.75	8000	6000	175
HCDS88-SO	0.250 - 0.880	#4 - 556.5	#2 - 556.5	1	1/2	10.13	5.00	1.00	10000	6000	228

### Notes:

- 1) Add suffix "-HP" for helix clevis pin
- 2) Add suffix "-TP" for tin plating
- 3) Recommended torque on U-Bolts: 1/2" - 40-45 ft/lbs.