

ASSEMBLY INSTRUCTION

TUFTED WINGBACK FULL/QUEEN/KING HEADBOARD

A Headboard **B** Left Wooden Frame **C** Right Wooden Frame **D** Left Side Panel **E** Right Side Panel



1pc

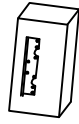

1pc

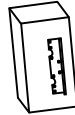

1pc

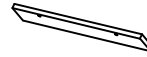

1pc



1pc

F Bolt
1/4" x 50mm



10pcs

G Flat Washer



10pcs

H Lock Washer



10pcs

I Allen Wrench



1pc

J Back Cover



1pc

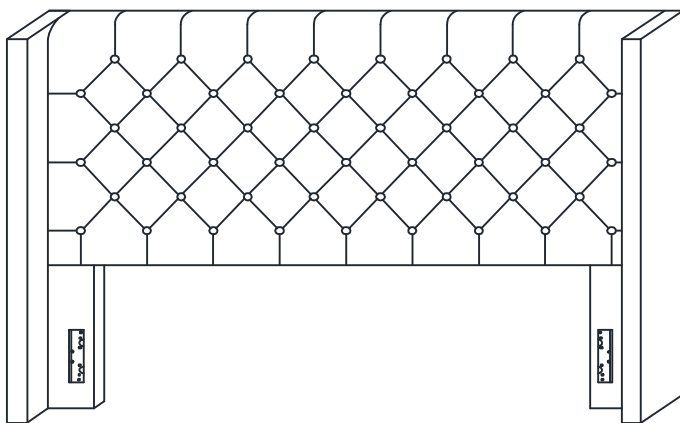

This page lists all the contents included in the box. Please take the time to identify the hardware as well as the individual components to this product. As you unpack and prepare for assembly, place the contents on a carpeted or padded area to protect them from damage.

-
- 1** Attached Wooden Frame (B) (C) to the Headboard (A) use Bolt (F), Lock Washer (H) and Flat Washer (G). Turn the Allen Wrench (I) in Bolt (F).

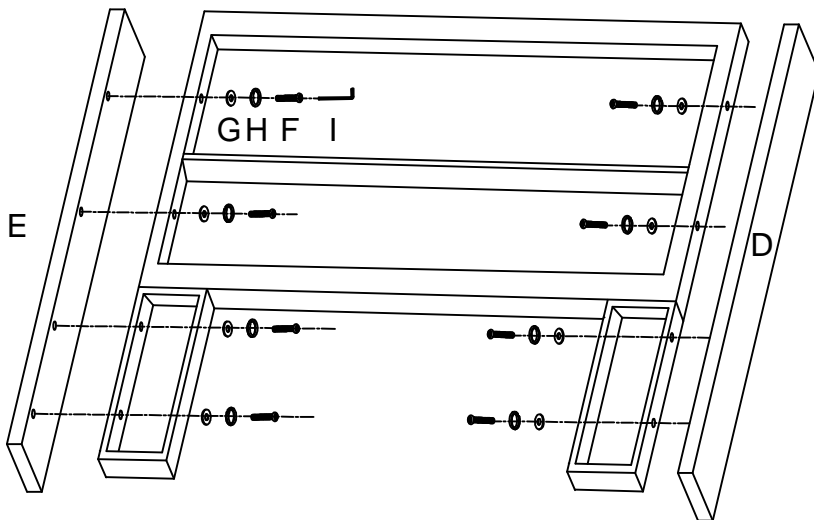
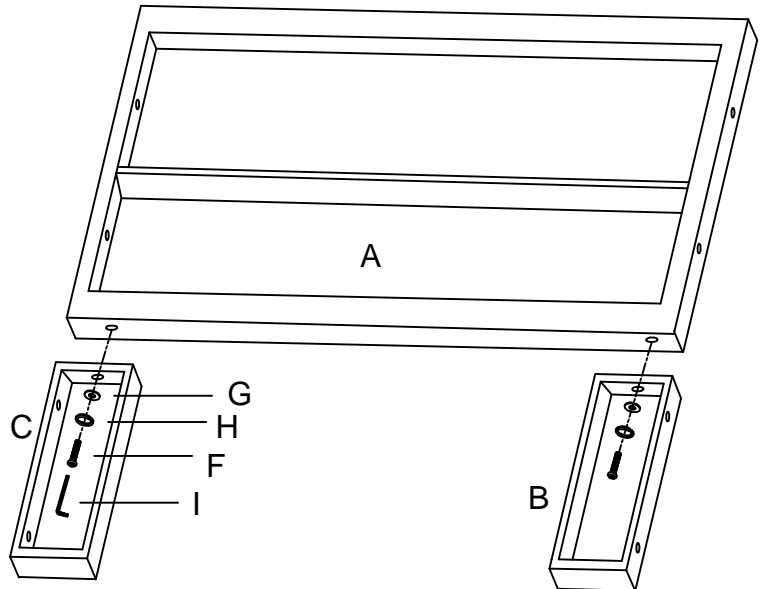

-
- 2** Attached Side Panel (D) (E) to the Headboard (A) use Bolt (F), Lock Washer (H) and Flat Washer (G). Turn the Allen Wrench (I) in Bolt (F)

-
- 3** Stick the Back Cover (J) on the back of the Headboard (A).

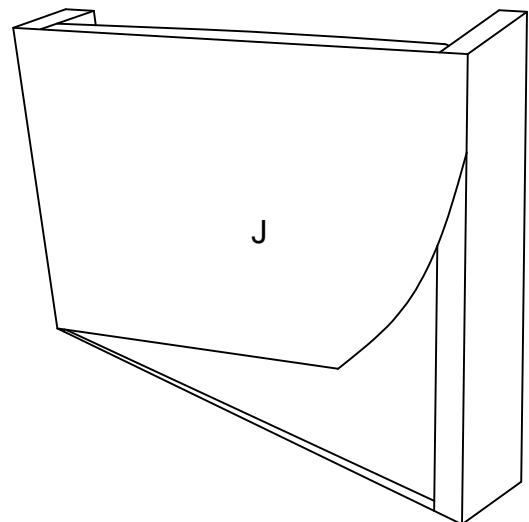

Cleaning & Care

Treat surface with care. Surface is resistant to scratches but is not scratch resistant. Clean surfaces with a dry or damp soft cloth. Do not use abrasive cleaners. Hardware may loosen over time. Periodically check that all connections are tight.

ASSEMBLY INSTRUCTION

WINGBACK KING BED WITH REGULAR SLATS

A Footboard



1 pc

B Side Rails

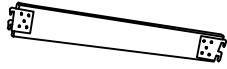

2 pcs

C Wooden Leg

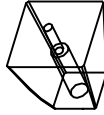

2 pcs

D Support Leg



15 pcs

E Wooden Slat

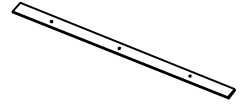

5 pcs

F Screw



20 pcs

G Bolt
1/4" x 75mm



2 pcs

H Bolt
1/4" x 50mm

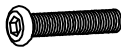

15 pcs

I Flat Washer



17 pcs

J Lock Washer



17 pcs

K Allen Wrench



1 pc

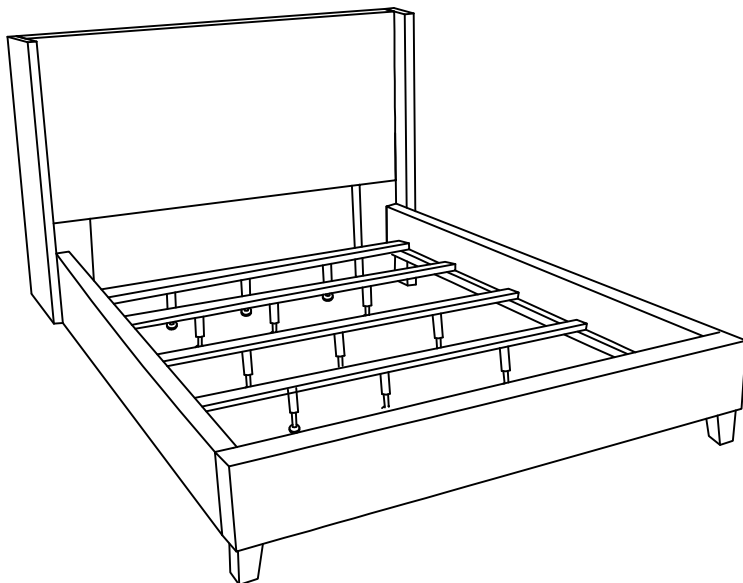

This page lists all the contents included in the box. Please take the time to identify the hardware as well as the individual components to this product. As you unpack and prepare for assembly, place the contents on a carpeted or padded area to protect them from damage.

- 1** Attached Wooden Leg (C) to the Footboard (A) use Bolt (G), Lock Washer (J) and Flat Washer (I) on both of holes. Turn the Allen Wrench (K) in Bolt (G).

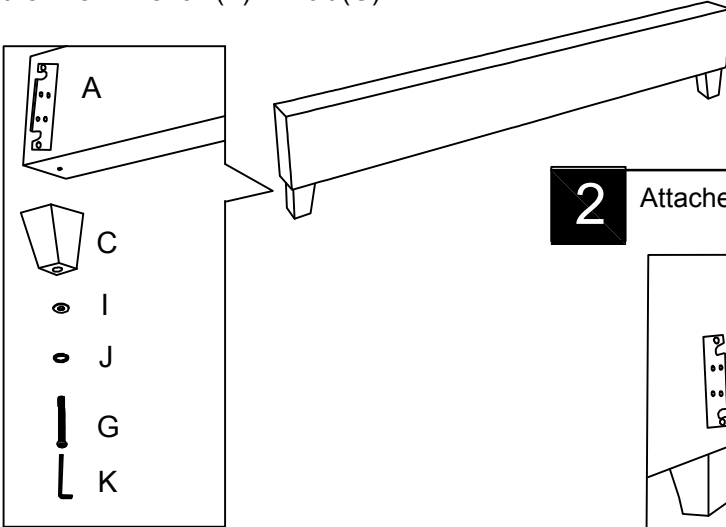

- 2** Attached Side Rail (B) to the Headboard and Footboard (A).

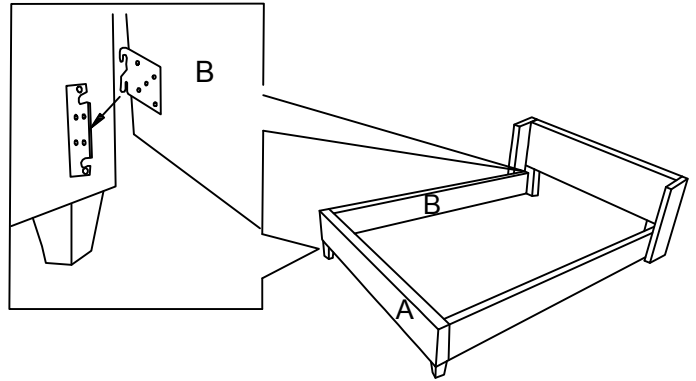

- 3** Assembly Wooden Slats (E) and Support Leg (D) use Flat Washer (I), Lock Washer (J) and Bolt (H), Turn the Allen Wrench (K) in Bolt (H).

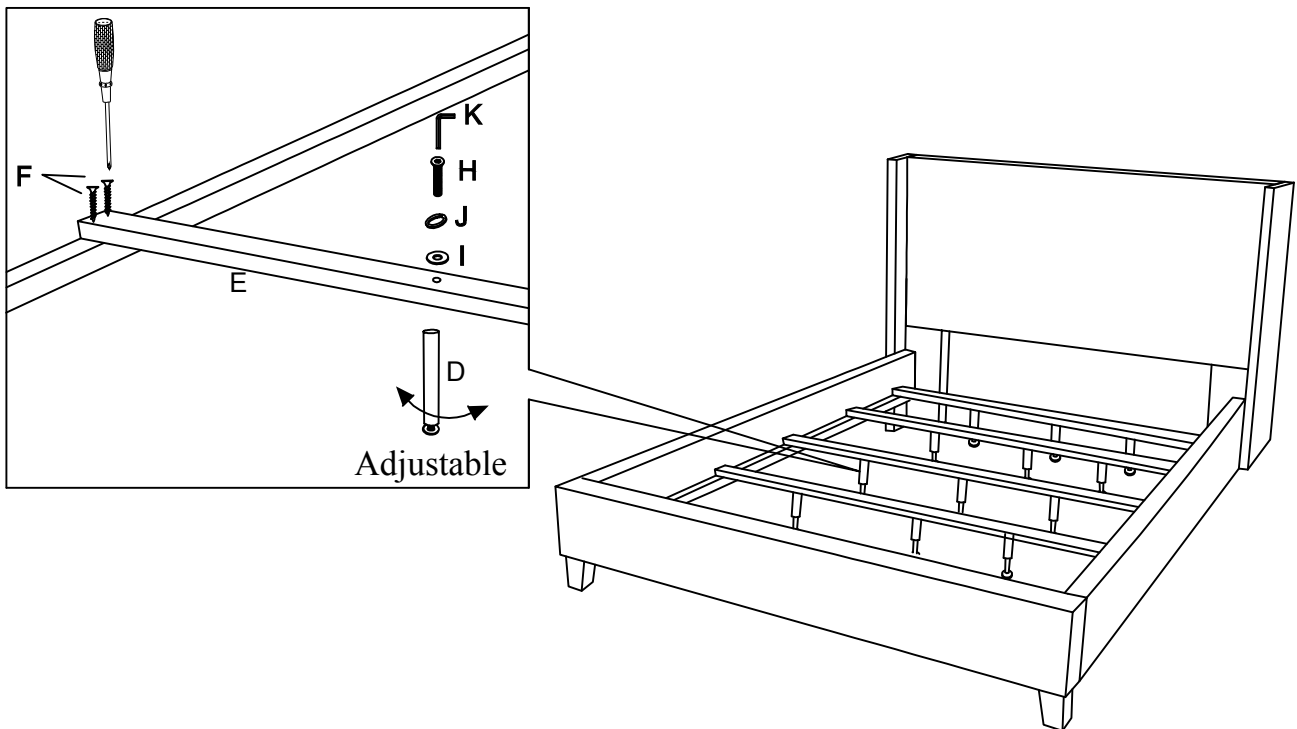

Cleaning & Care

Treat surface with care. Surface is resistant to scratches but is not scratch resistant. Clean surfaces with a dry or damp soft cloth. Do not use abrasive cleaners. Hardware may loosen over time. Periodically check that all connections are tight.