

### Step 1. Position Template

- Fold the template as indicated.
- Place it on the door edge at the desired height.
- Hold firmly and mark the handle fixing holes according to the template.

### Step 2. Mark and Drill Holes

- Drill 2 x 10mm holes at 60mm backset as marked.

### Step 3. Install Lever Assembly to Door

- Remove rosette cover (1) from lever assembly.
- Secure the threaded post (2) to the under rose (3) using the fully threaded short screw (4).
- Select the appropriate partially threaded long screw (5) (40mm or 48mm) based on your door thickness.
- Pass the screw through the backplate (6) and secure to the under rose.
- Insert the second fully threaded short screw (7) through the backplate and into the threaded post.
- Ensure lever is level before tightening screws securely.
- Re-apply rosette cover (1) to under rose by pushing cover over the rubber ring till flush with the door.

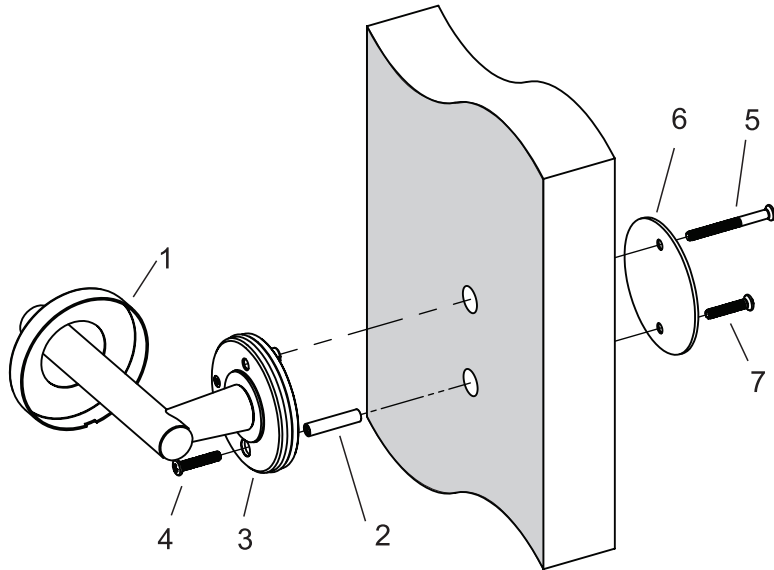

**NOTE:** Carefully follow these instructions when installing. Screws to be hand tightened to a recommended 2.5Nm torque.



⚠️ PRINT TO SCALE

FOLD HERE

FOLD HERE

Fit here on door edge

Fit here on door edge

template

BACKSET 60mm

2 x 10mm hole



Suits doors 32mm to 45mm thick.

Note: Drilling of pilot holes and drilling from both sides of the door is recommended.



**ALLEGION™**

**Allegion (New Zealand) Limited**  
 Freephone 0800 477 869  
 Email nzinfo@allegion.com  
 www.allegion.co.nz



01/2026  
 PDSC0026-R2