





# ASSEMBLY INSTRUCTIONS

8 - 1219

## SERVANT CONSOLE

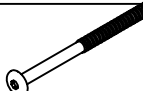
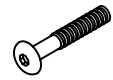
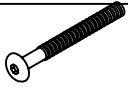
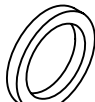
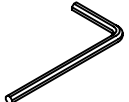
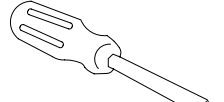
**HEKMAN**  
A HOWARD MILLER COMPANY

### HARDWARE ENCLOSED

- |   |   |   |
|---|---|---|
|  |  |  |
| ( A ) JCBC 6 X 100<br>4 Pcs   | ( B ) JCBC 6 X 40<br>4 Pcs  | ( C ) JCBC 6 X 60<br>4 Pcs  |
|  |  |  |
| ( D ) FLAT WASHER<br>12 Pcs   | ( E ) ALLEN KEY<br>1 Pcs  | ( F ) SCREW DRIVER +<br>1 Pcs   |
|  |  |  |
| ( G ) BOLT JMT 4x40<br>4 Pcs  | OPTION #1<br>( H ) KNOB 1.5"<br>4 Pcs   | OPTION #2<br>( I ) LION HEAD<br>4 Pcs   |

\*Do not tighten bolts from leg to top assembly until stretcher is in place and stretcher bolts have been started. When all bolts are finger tight then start to fullytighten bolts"

### STEP 1

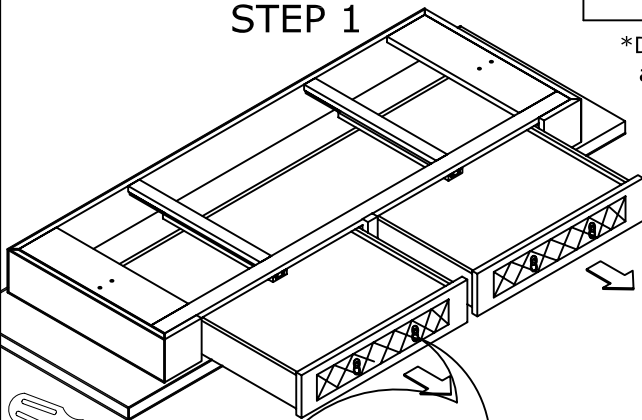

### STEP 3

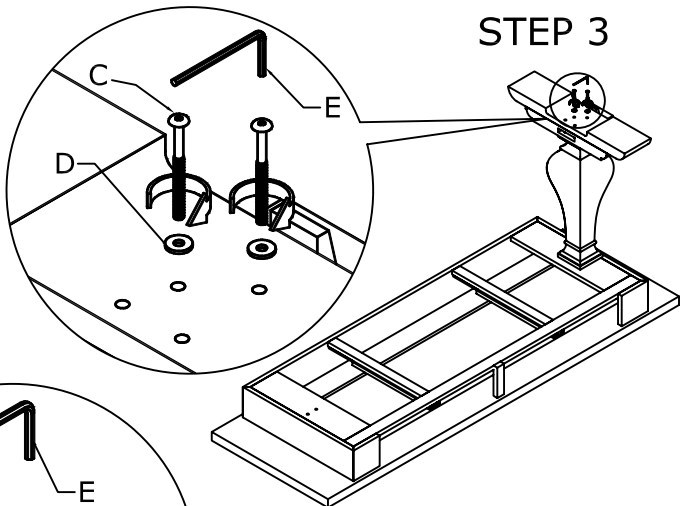

### STEP 2

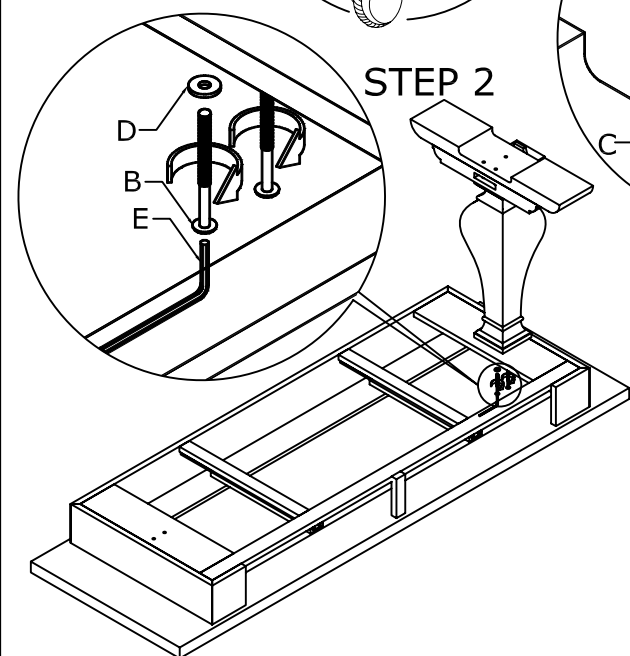

### STEP 4

