



Manufactured by:
Backyard Discovery
3305 Airport Drive, Pittsburg, KS 66762
800-856-4445

Basepoint Business Centre: Rivermead Drive, Westlea, Swindon SN5 7EX Phone: 0800-118-2476 J.P. Coenstraat 7, The Bridge, The Hague, 2595 WP, Netherlands Phone: 08005678990

12x10 ARLINGTON GAZEBO GUTTER KIT MODEL #: 9240414



Please visit www.backyarddiscovery.com
For the most up to date assembly manual, to register your product, or to order
replacement parts Para obtener instrucciones en español, visite
www.backyarddiscovery.com

OWNER'S MANUAL - PARTS IDENTIFICATION

Hardware Components



H101415 SCREW SELF PIERCING #8x1/2
(x10)

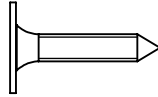

H101205 SCREW PWH BLK
(x8) 8x3/4

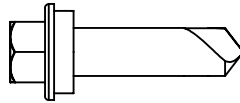

H101480 SCREW SELF TAPPING #9x1 BLK
(x10) 1/4 x 1

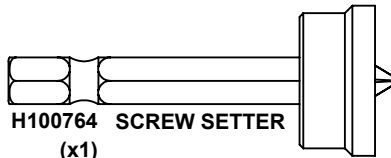

H100764 SCREW SETTER
(x1)

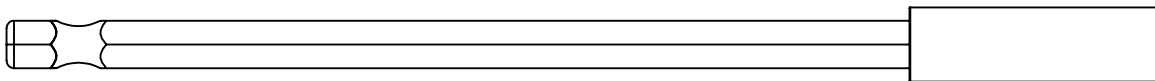

H101278 6" MAGNETIC DRIVER EXTENSION
(x1)



A6P01531 10 OZ SILICONE TUBE
(x1)

OWNER'S MANUAL - PARTS IDENTIFICATION

Hardware Components

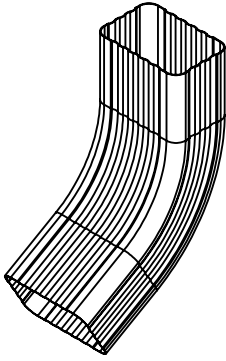

A4M05880 DOWNSPOUT ELBOW
(x2) 3"x10 7/16"x10 11/16"

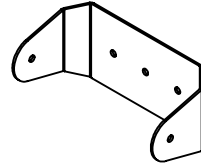

A4M06338 DOWNSPOUT CLIP
(x4) 1 7/16"x1 7/16"x3 1/8" [36x36x79]

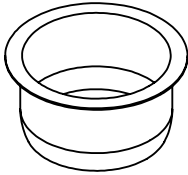

A4M04761 DOWNSPOUT OUTLET
(x2) 1 7/16"x2 7/8" [37x73]

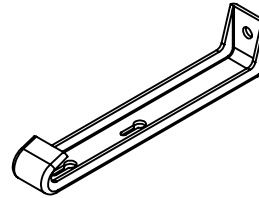

A4M04759 GUTTER HANGER
(x10) 3/4"x1"x4 15/16" [19x25x125]

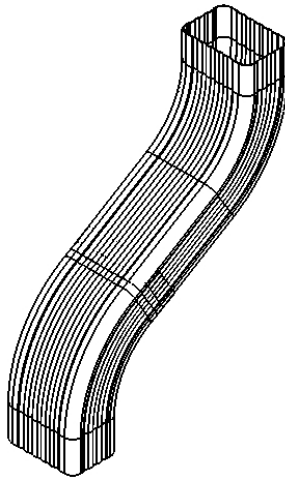

A4M05878 DOWNSPOUT OFFSET - 8IN
(x2) 3"x9 5/8"x12 9/16"



A4M06340 DOWNSPOUT - 60"
(x2) 2"x3"x60" [51x76x1525]

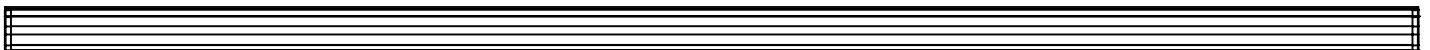

A4M06827 GUTTER W/ OUTLET
(x2) 3 11/16"x5 1/8"x117 3/4"

PRE-ASSEMBLY STEP 1 - SORTING PARTS

It is critical for ease of assembly that you take the time to sort and organize the parts and hardware.

HARDWARE PARTS:

- We recommend that you have a separate table to organize the hardware.
- Hardware bags are printed with a seven-digit, alpha-numeric part number.
- You can organize your hardware by part number or group by hardware type (e.g. bolts, nuts, etc.).
- During assembly you only need to reference the last four digits of the number.



TOOLS REQUIRED:



Cordless Drill or
Electric Drill



Caulk Gun



Tape Measure



1/8" Drill Bit

OFFSET ORIENTATION

TO ENSURE WATER FLOWS PROPERLY, IT IS IMPORTANT TO ORIENT DOWNSPOUT PIPING CORRECTLY. STARTING AT THE TOP, DOWNSPOUTS MUST FEED INTO THE NEXT SECTION AS SHOWN.

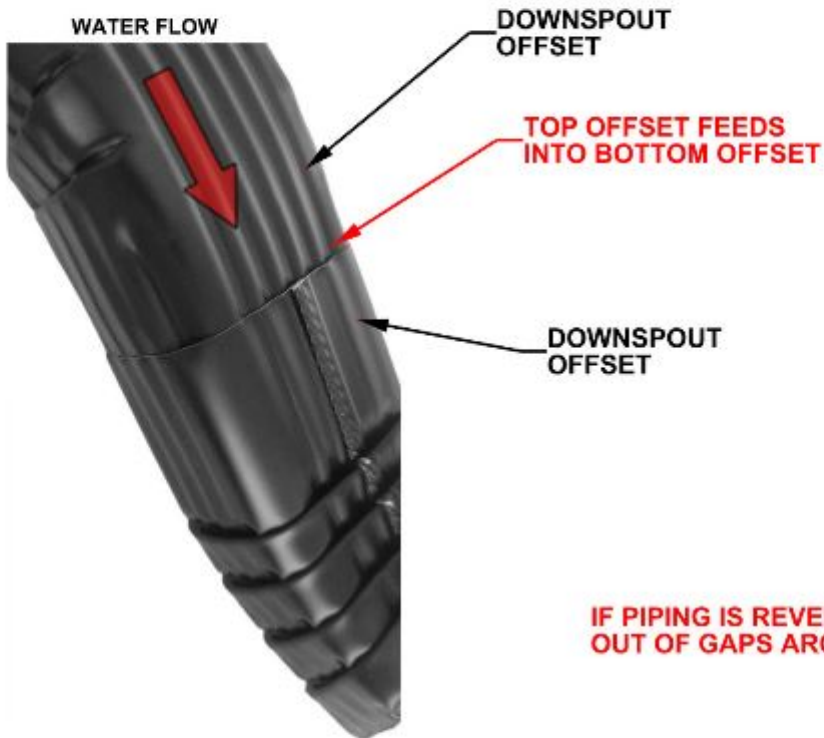

IF PIPING IS REVERSED, WATER WILL RUN OUT OF GAPS AROUND JOINTS

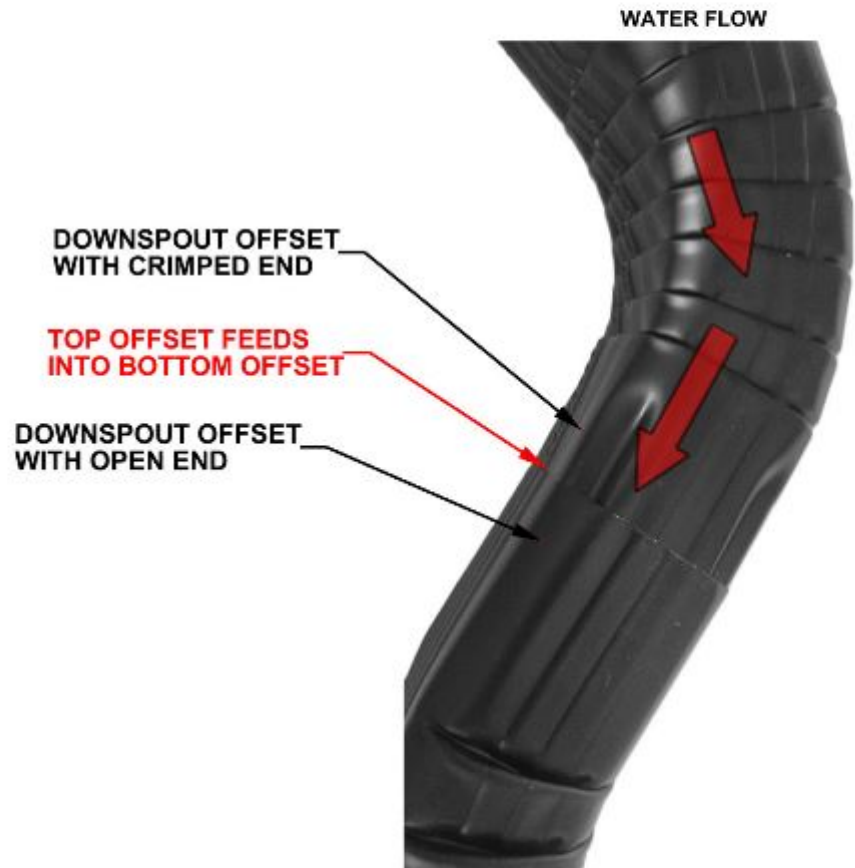

GUTTER SPLICE PAGE

- NOTE:**
- APPLY SILICONE TO INSIDE CHANNEL ON BOTH SIDES.
 - ENSURE SILICONE IS EVENLY APPLIED ALONG THE CHANNEL.
 - AFTER GUTTER SPLICE HAS BEEN SLID ONTO GUTTERS AND SILICONE HAS HAD TIME TO CURE, USING HAND PRESSURE ONLY, FOLD THE TOP TAB OVER EDGE OF GUTTER

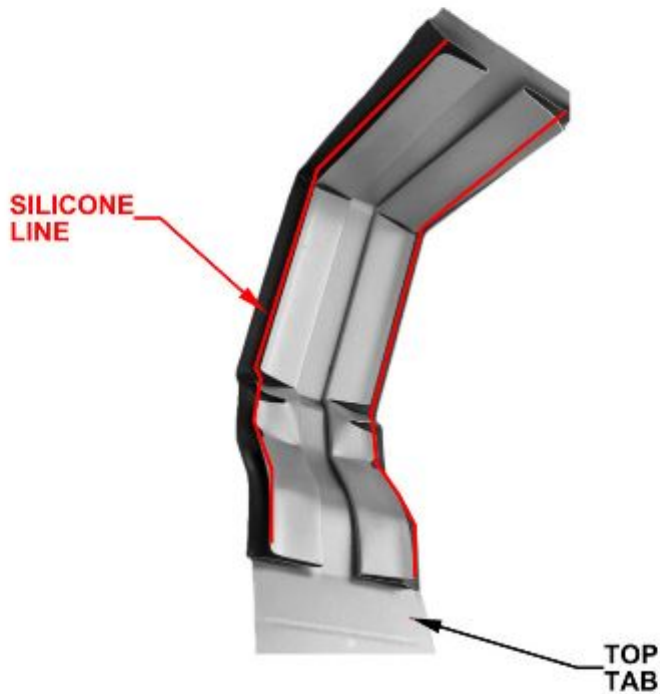
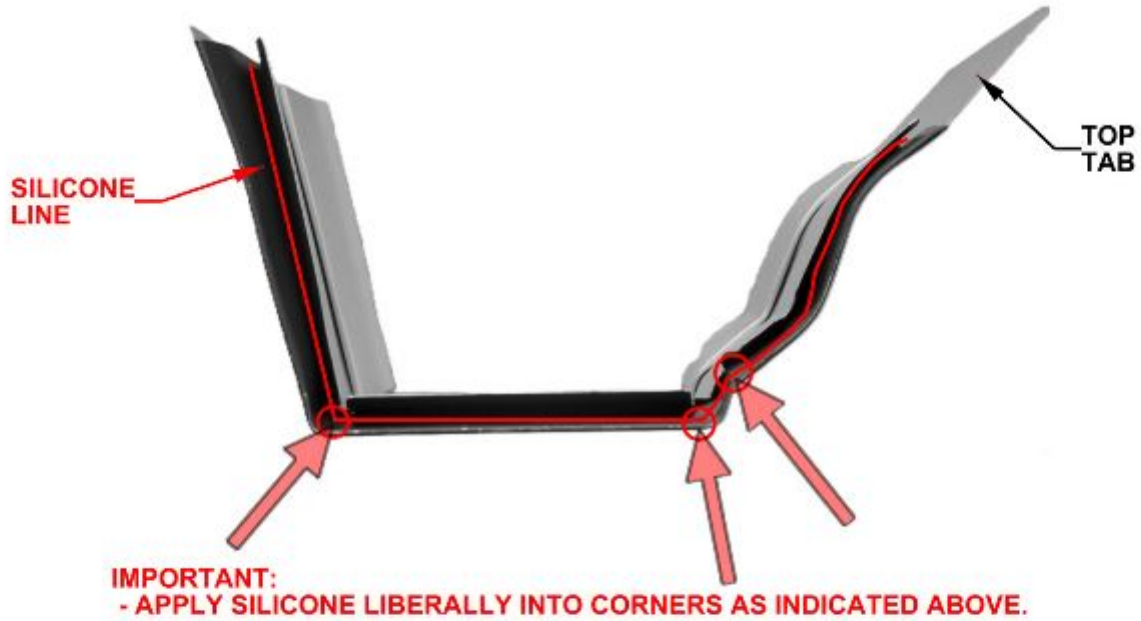

WAIT APPROXIMATELY 45 MINUTES FOR SILICONE TO BE COME TACKY.
AFTER 24 HOURS, SILICONE HAS CURED AND CAN HOLD WATER

STEP 1 - GUTTER ASSEMBLY

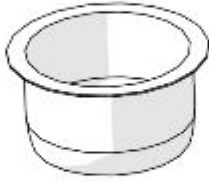

A4M04761 DOWNSPOUT OUTLET
(x2)



A4M06827 GUTTER W/ OUTLET
(x2)

- APPLY A BEAD OF SILICONE AROUND THE BOTTOM LIP OF THE DOWNSPOUT OUTLET AND PLACE OUTLET INSIDE GUTTER.
- COMPLETE THIS STEP TWICE.

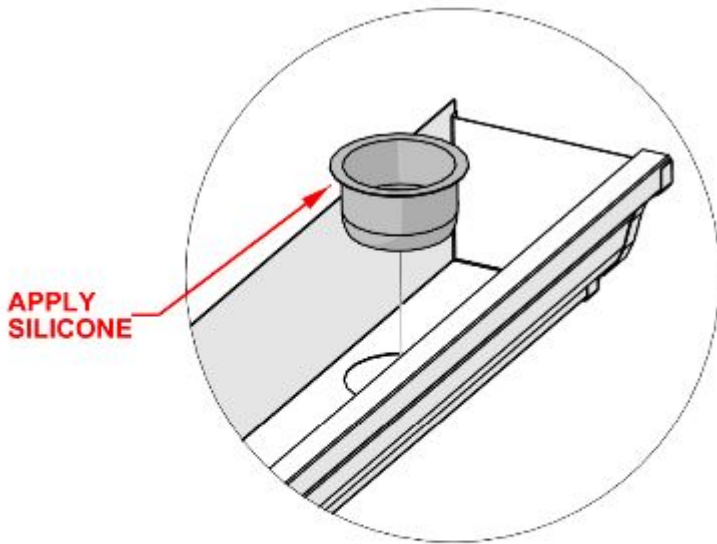

APPLY
SILICONE

TIP: PRESSURE MAY NEED TO BE APPLIED TO GET OUTLET INTO POSITION. USE A WET FINGER TO FLATTEN SILICONE AFTER INSTALL.

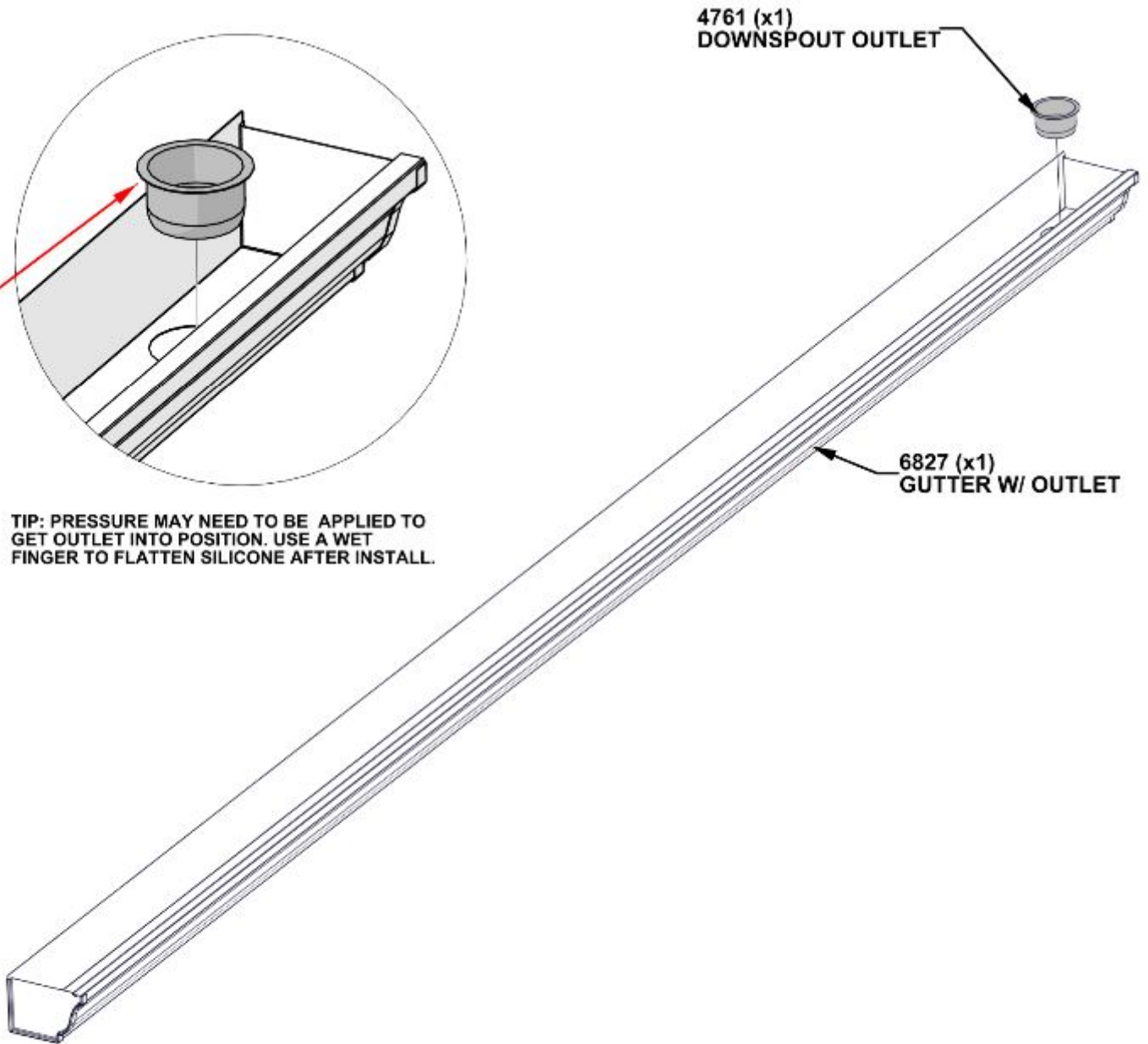

4761 (x1)
DOWNSPOUT OUTLET

6827 (x1)
GUTTER W/ OUTLET

STEP 2 - GUTTER ASSEMBLY



GUTTER W/ OUTLET ASSEMBLY - STEP 1
(x2)

QTY	PART NUMBER	DESCRIPTION
4	H101480	SCREW SELF TAPPING #9x1 BLK

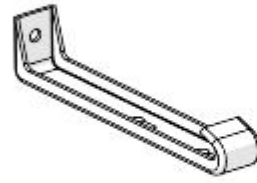

A4M04759 GUTTER HANGER
(x4)

- SLIDE GUTTER UP TO ROOF METAL.
- FLUSH GUTTER WITH FASCIA BOARD.
- GUTTER HANGERS WILL BE INSTALLED APPROXIMATELY 3" [75mm] FROM THE INSIDE OF GUTTER.
- GUTTER HANGER WILL BE INSTALLED AT A DOWNWARD ANGLE TO AVOID EDGE TRIM.
- PRE-DRILL 1/8" [3mm] PILOT HOLES FOR EASE OF ASSEMBLY.

- **COMPLETE THIS STEP ON BOTH SIDES.**
- **DOWNSPOUTS WILL BE AT OPPOSITE CORNERS.**

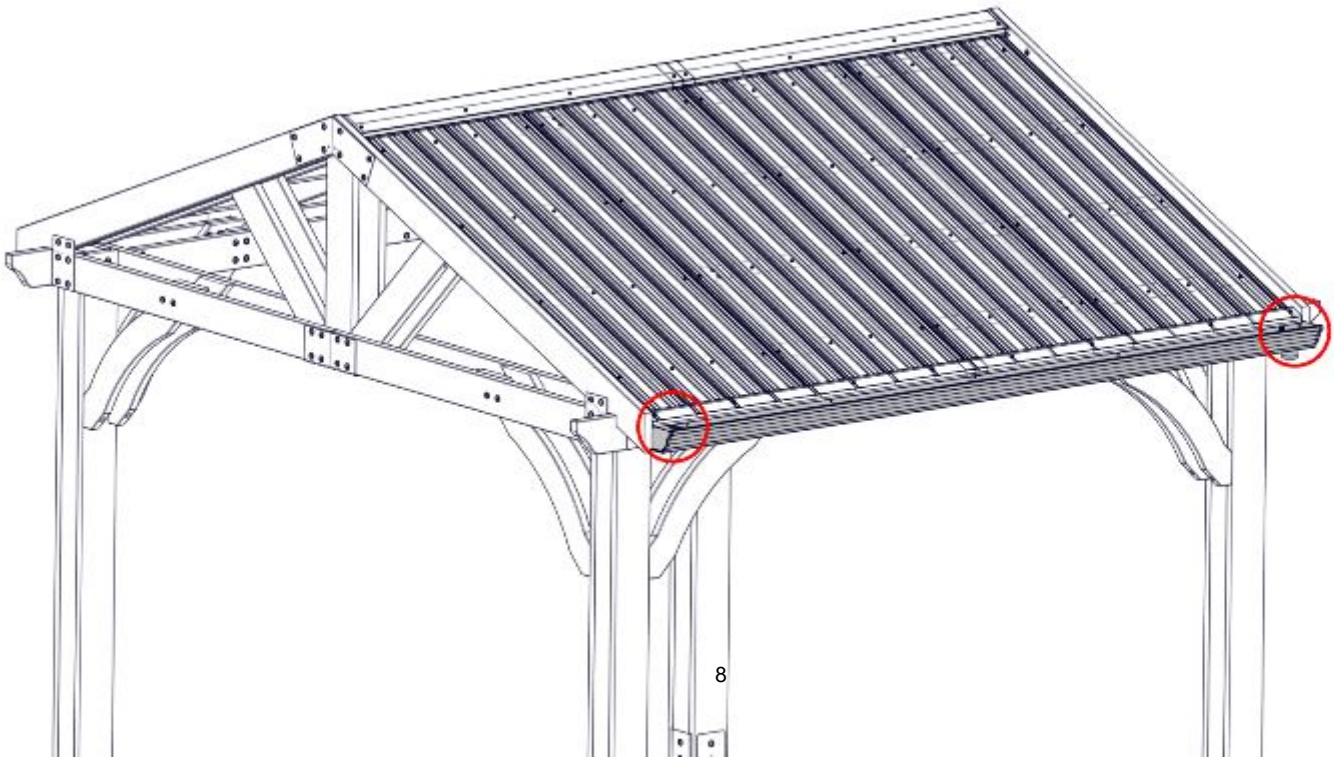
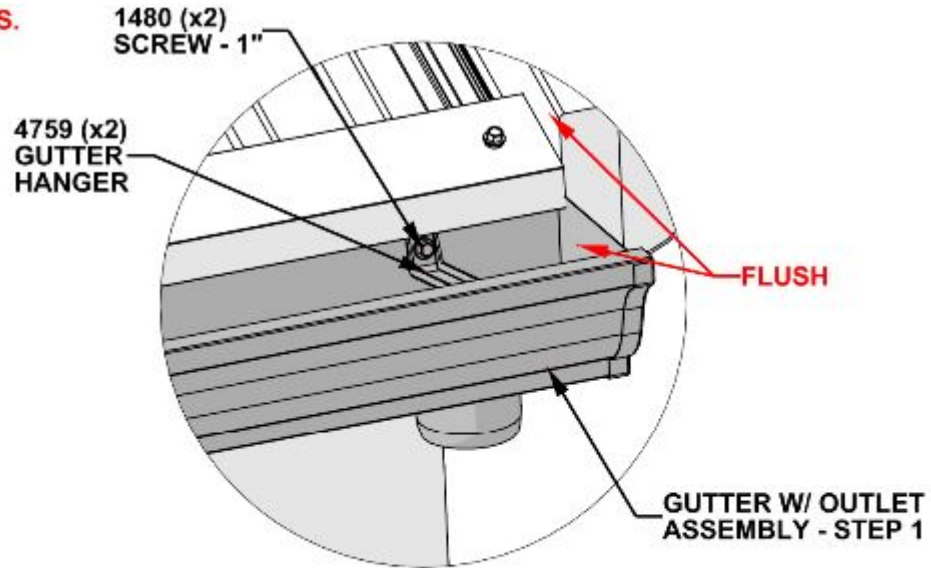

STEP 3 - GUTTER ASSEMBLY

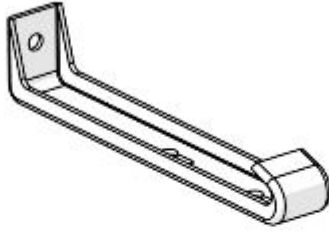

A4M04759 GUTTER HANGER
(x6)

QTY	PART NUMBER	DESCRIPTION
6	H101480	SCREW SELF TAPPING #9x1 BLK

- ATTACH REMAINING GUTTER HANGERS ON BOTH SIDES.
- START WITH THE MIDDLE HANGER.
- EVENLY SPACE HANGERS.

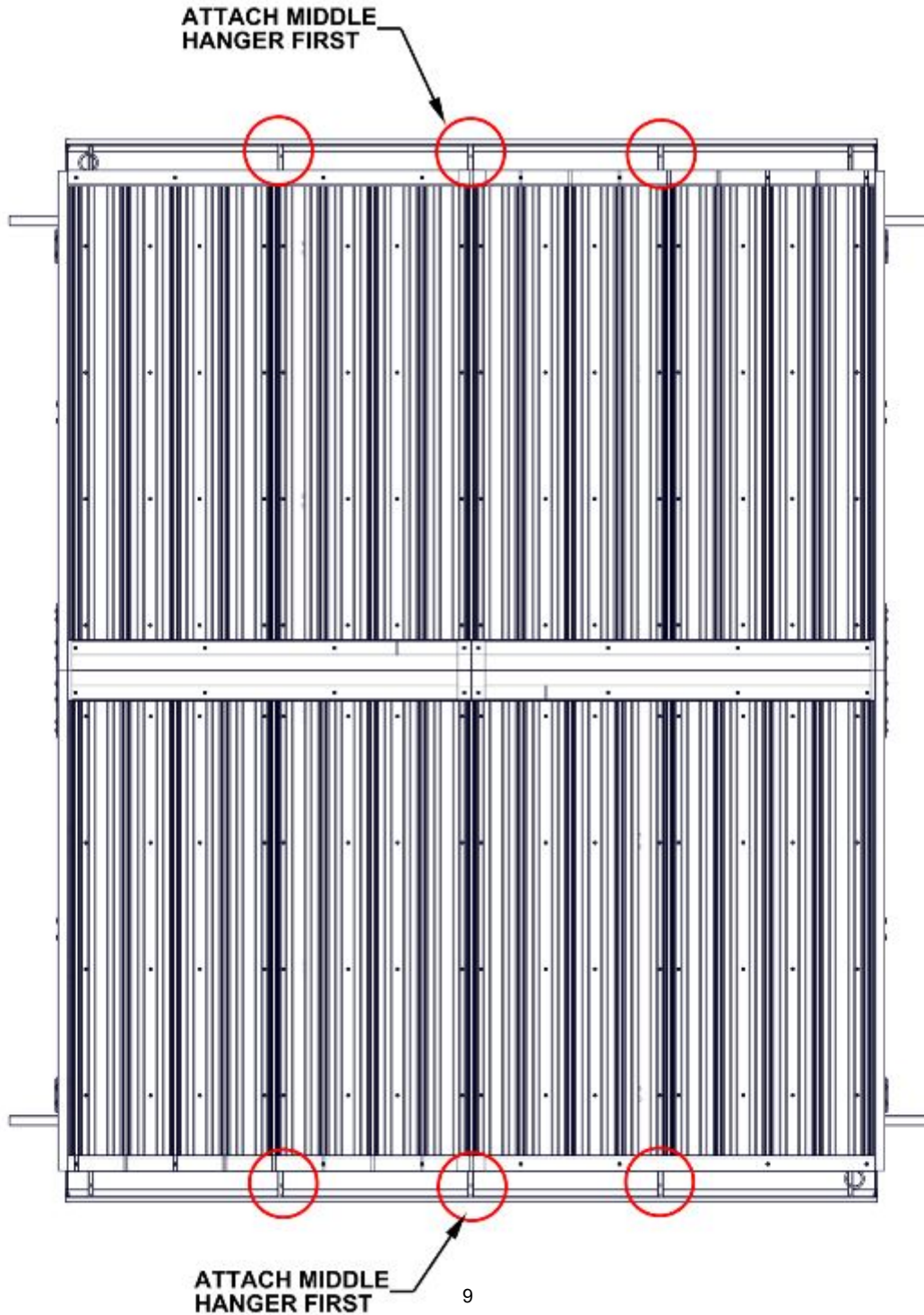

STEP 4 - GUTTER ASSEMBLY

QTY	PART NUMBER	DESCRIPTION
8	H101205	SCREW PWH 8x15x3/4 BLK

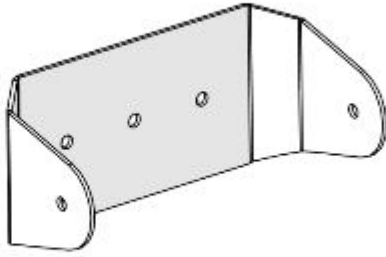

A4M06338 DOWNSPOUT CLIP
(x4)

- IT IS IMPORTANT TO CENTER 4782 CLIP AND HARDWARE ON POST AS SHOWN.
- ATTACH GUTTER CLIP APPROXIMATELY 15-3/4" [400mm] AND 74-1/4" [1885mm] OFF THE GROUND.

ATTENTION:
IF MOSQUITO NETTING IS ATTACHED, ZIP NETTING TOGETHER TO ENSURE IT CLOSES COMPLETELY AND IS PULLED TIGHTLY, THEN FASTEN CLIP ON TOP OF NETTING.

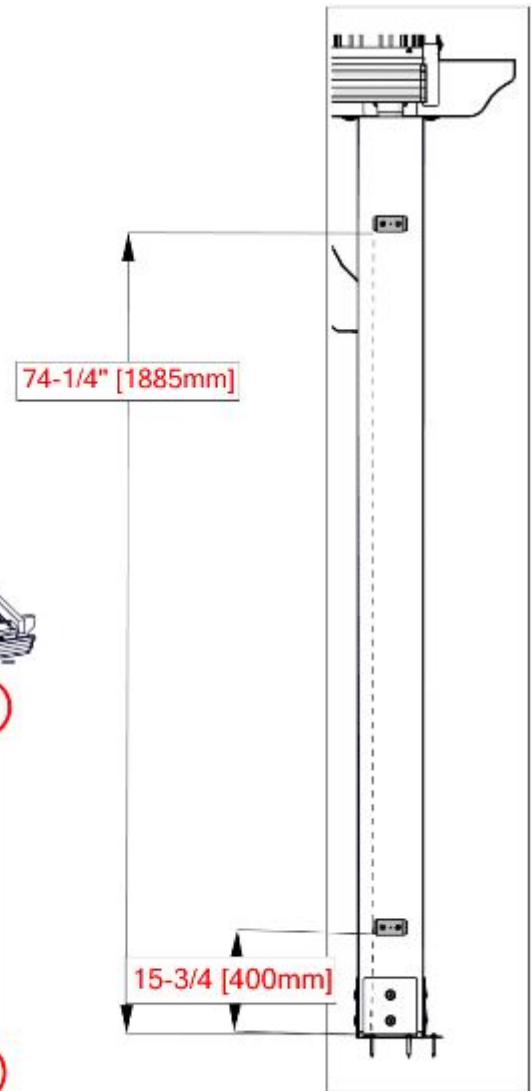
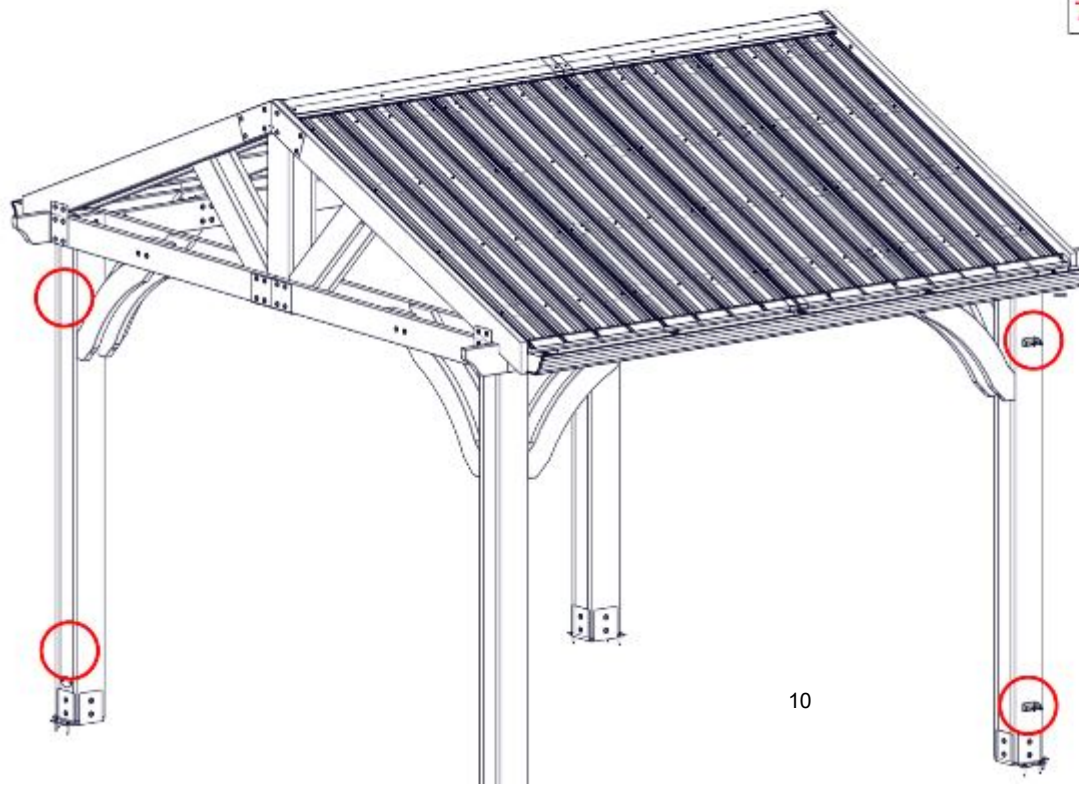
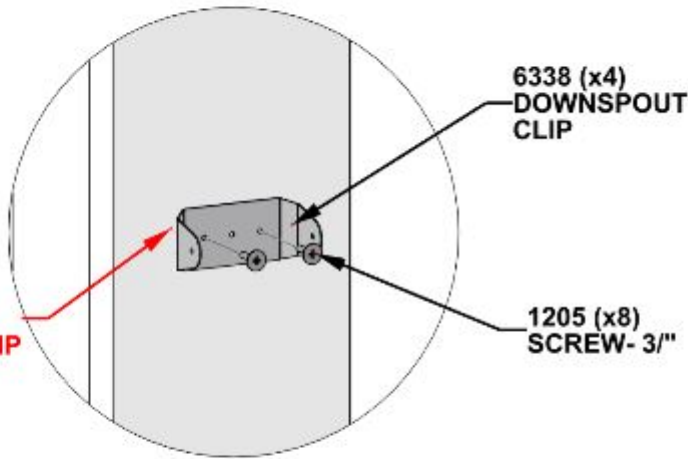

STEP 5 - GUTTER ASSEMBLY



A4M05880 DOWNSPOUT ELBOW - LONG
(x2)



A4M06340 DOWNSPOUT - 60"
(x2)



A4M05878 DOWNSPOUT OFFSET - 8"
(x2)

- INSERT TAPERED ENDS INTO LARGER ENDS AS SHOWN.
- NOTE ORIENTATION OF DOWNSPOUT OFFSET. SEE DOWNSPOUT OFFSET PAGE FOR DETAIL.
- COMPLETE THIS STEP TWICE.

5878 (x1)
DOWNSPOUT OFFSET - 8IN

TAPERED
END

NOTE TOP OFFSET
ELBOW GOES INSIDE
BOTTOM OFFSET ELBOW

6340 (x1)
DOWNSPOUT - 60"

TAPERED
END



5880 (x1)
DOWNSPOUT ELBOW - LONG

STEP 6 - GUTTER ASSEMBLY



DOWNSPOUT ASSEMBLY - STEP 5
(x2)

QTY	PART NUMBER	DESCRIPTION
2	H101415	SCREW SELF PIERCING #8x1/2 BRN

- SLIDE DOWNSPOUT ASSEMBLY OVER GUTTER OUTLET AND ATTACH WITH HARDWARE PROVIDED.
- NOTE GUTTER WILL NOT EXTEND TO GROUND, THERE WILL BE FLOATING SPACE.
- COMPLETE AT BOTH DOWNSPOUT POSITIONS.

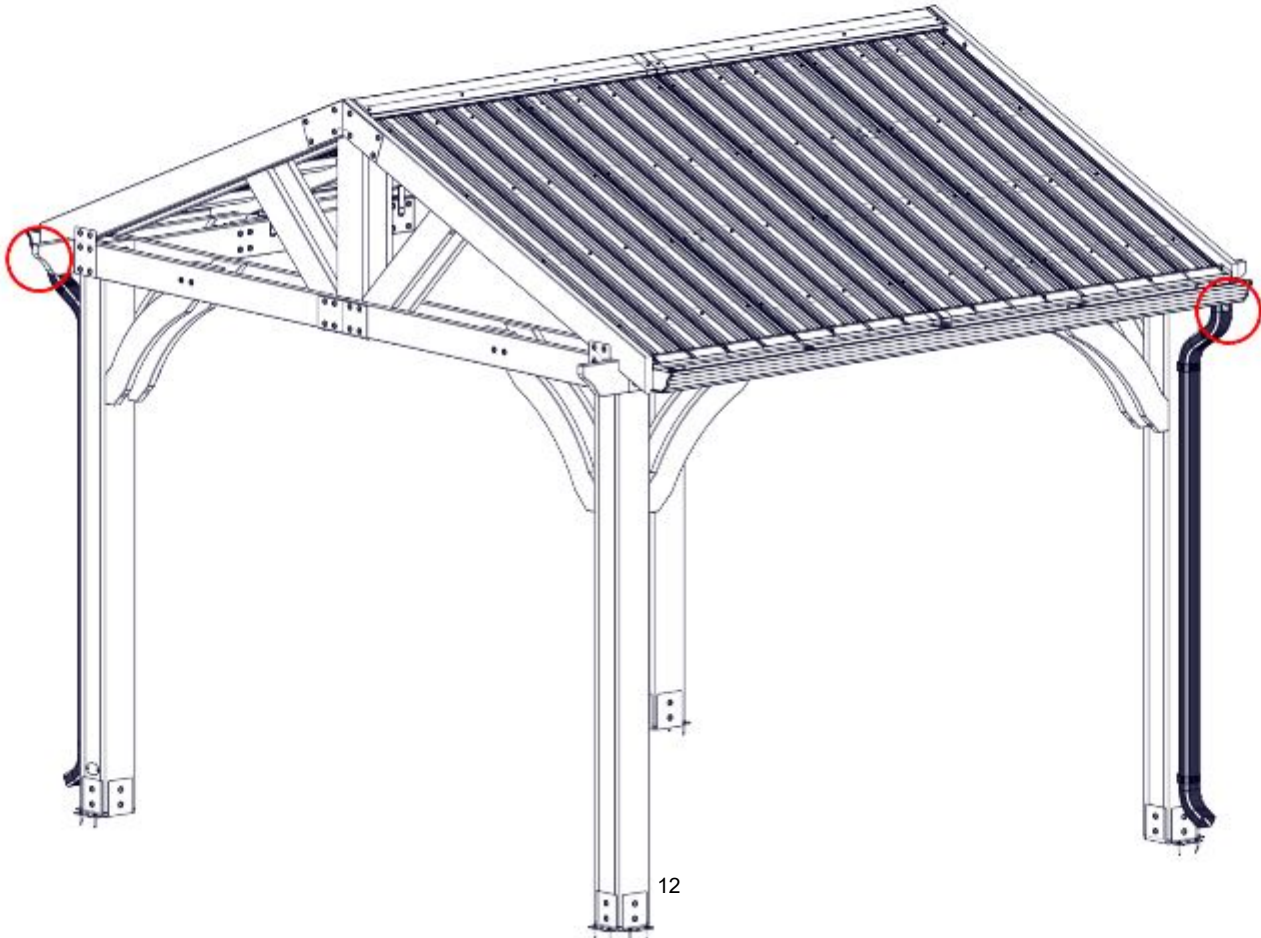
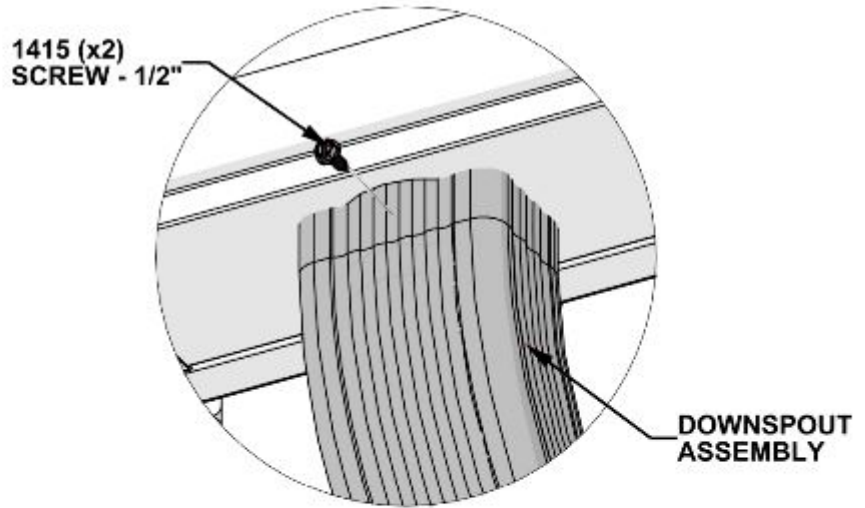

STEP 7 - GUTTER ASSEMBLY

QTY	PART NUMBER	DESCRIPTION
8	H101415	SCREW SELF PERCING #8x1/2 BRN

- FASTEN DOWNSPOUT CLIP TO DOWNSPOUT USING HARDWARE PROVIDED.
- COMPLETE THIS STEP AT BOTH DOWNSPOUTS.

