

WALKER EDISON

TM

25" Solid Wood 2 Drawer Night Stand with Gallery

SKU# BR2DRLEENS

LOT: AAYYWW-XXX



For Residential Use Only

Please visit our website for the most current instructions, assembly tips, report damage, or request parts. www.walker-edison.com

WE Time to get started

Set up a clean and soft workplace to avoid damage during assembly. You can use the box and internal protections as cover. It also helps to double-check if you've got all the pieces and parts before diving in assembly.

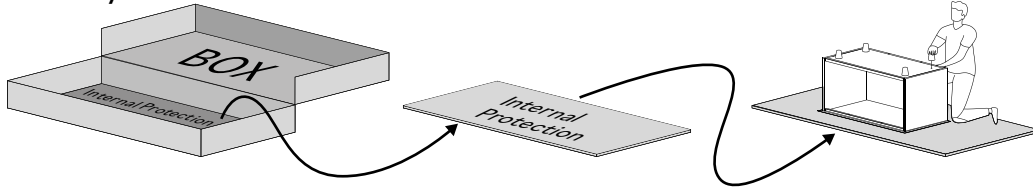

**Estimated time
for assembly**

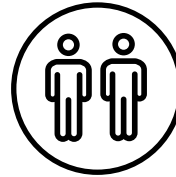

2 People Build

**People recommended
for assembly**

Make it a team effort!
Grab a friend for quicker,
easier assembly.

Tools Needed

Grab a Phillips head screwdriver to conquer this assembly. We will also need a hammer to help.

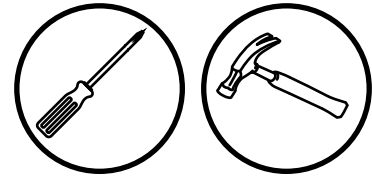

Use power tools with caution

This furniture is made of Solid Wood and Composite Wood, soft materials. If you choose to use power tools, set it to the slower setting. Be careful! Power tools can cause cracking or damage to the furniture, they can also damage the hardware if misused.

Power tool damages are not covered by the Walker Edison warranty.

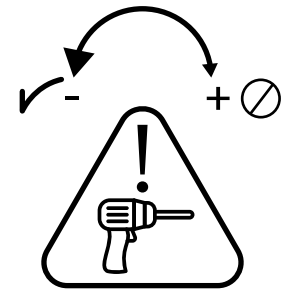

Slide care

Your furniture has highly durable wooden sliders. From time to time we recommend applying paraffin or standard candle wax to improve gliding of the sliders.

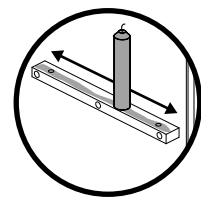

Scan to get assembly tips and help!









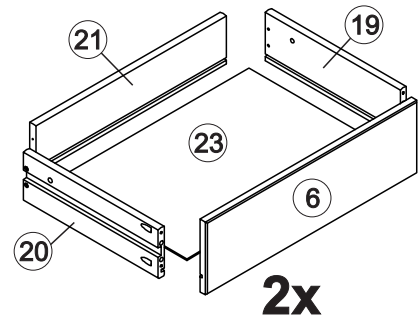
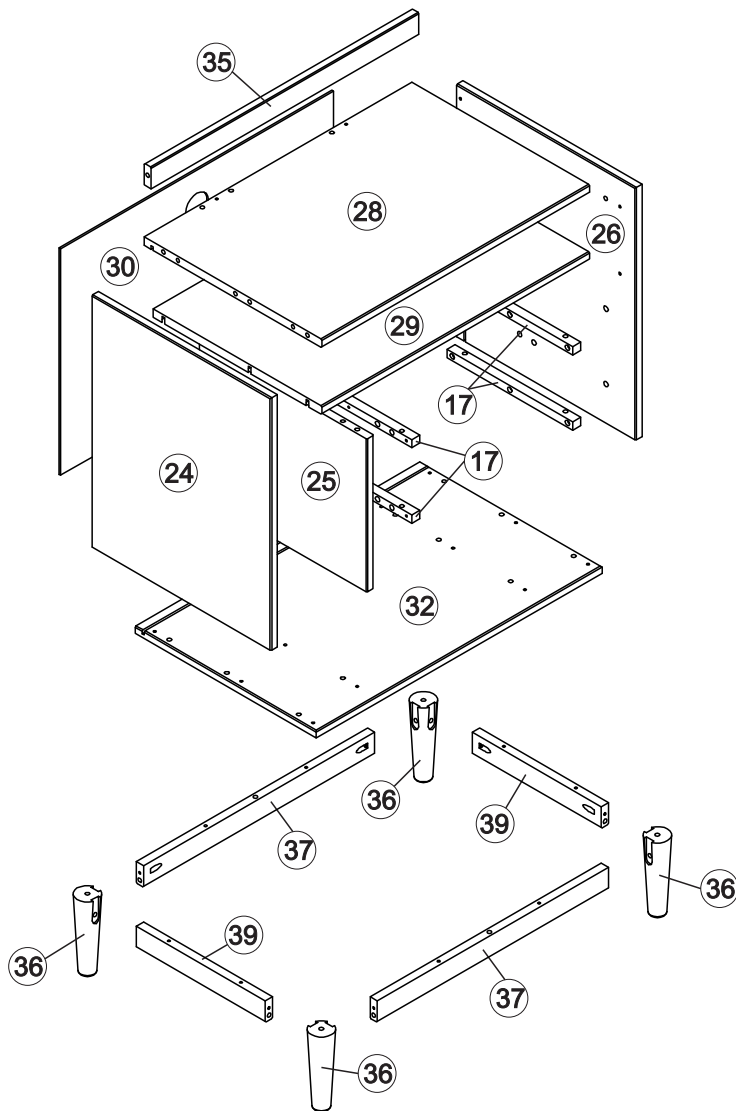

Parts List

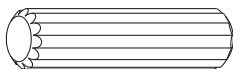
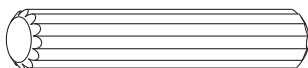
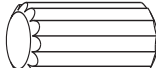
Part Number	Description	Quantity
6	Drawer Front	2
17	Wood Slider	4
19	Right Drawer Side	2
20	Left Drawer Side	2
21	Drawer Back	2
23	Drawer Bottom	2
24	Left Side Panel	1
25	Division	1
26	Right Side Panel	1

Part Number	Description	Quantity
28	Top	1
29	Shelf	1
30	Back Panel	1
32	Base Panel	1
35	Top Crossbeam	1
36	Foot	4
37	Bottom Front Crossbeam	2
39	Bottom Side Crossbeam	2

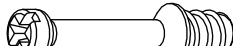

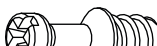
WE Hardware List

Part	Size	Name	Quantity
A	 Ø8*30mm	Wood dowel	47
B	 Ø8*40mm	Wood dowel	04
C	 Ø10*20mm	Wood dowel	12
D	 Ø3,0*12mm	Screw	04
E	 Ø4,0*25mm	Screw	12
F	 Ø3,5*30mm	Screw	18
G	 Ø4,0*40mm	Screw	22
H	 ø15*30mm	Cam bolt	14
I	 ø15*10mm	Cam lock	14
J	 -	Handle	02
K	 Ø8*8mm	Cam bolt	06
L	 -	Plastic lock	06
M	 -	Slap hole	06

The hardware quantities listed above are required for proper assembly.

Extra hardware pieces may be included.

Step 1

Let's get started. First step is inserting Wooden dowels (C) into Wood Sliders (17)

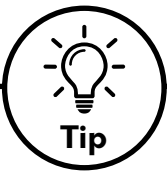
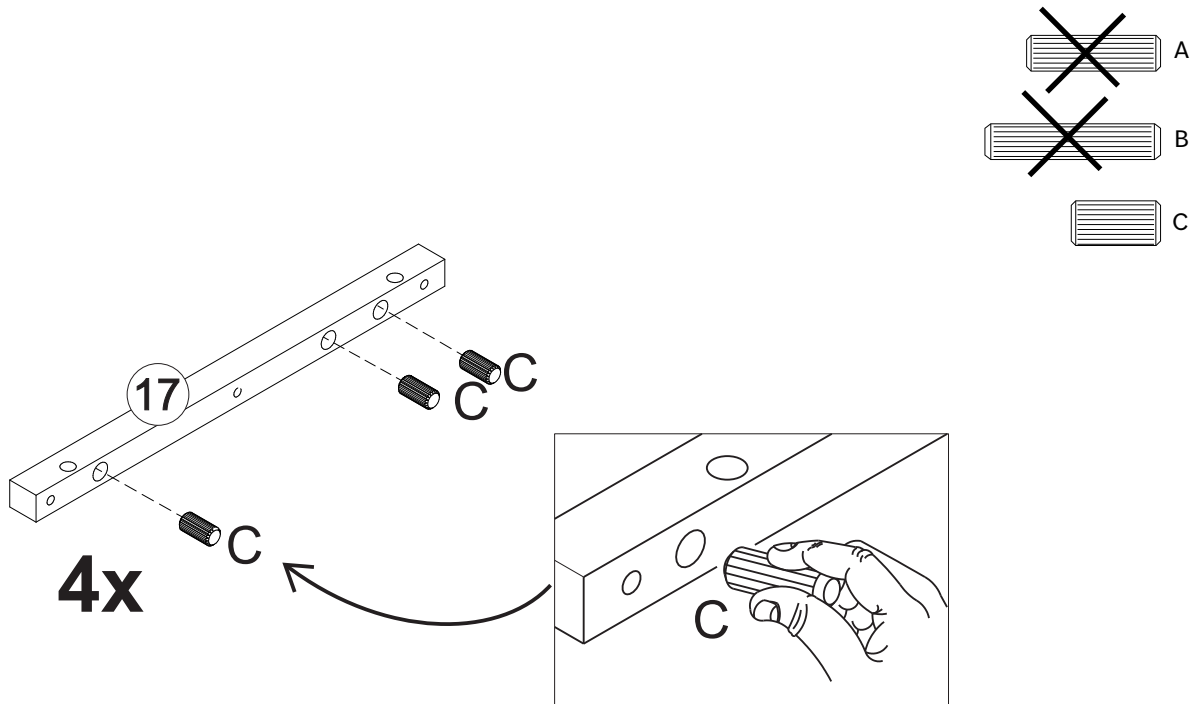

Tip

Wood Dowels

Dowels are essential in furniture assembly to create strong, precise connections.

They ensure structural integrity, prevent shifting, and simplify alignment, resulting in sturdier, longer-lasting furniture.

Follow these steps:

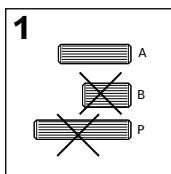

1: Select the appropriate size dowel according with step.

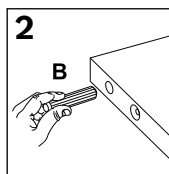

2: Insert into drilled hole and press firmly to ensure placement is set.

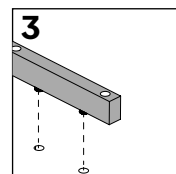
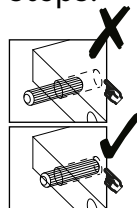

3: Align the dowel with corresponding piece and press together until secure.

Step 2

Insert Wooden dowel (A) into Right Drawer Side (19), Left Drawer Side (20), Left Side Panel (24), Division (25), Right Side Panel (26), Top (28), Top Crossbeam (35), Foot (36), Bottom Front Crossbeam (37) and Bottom Side Crossbeam (39).

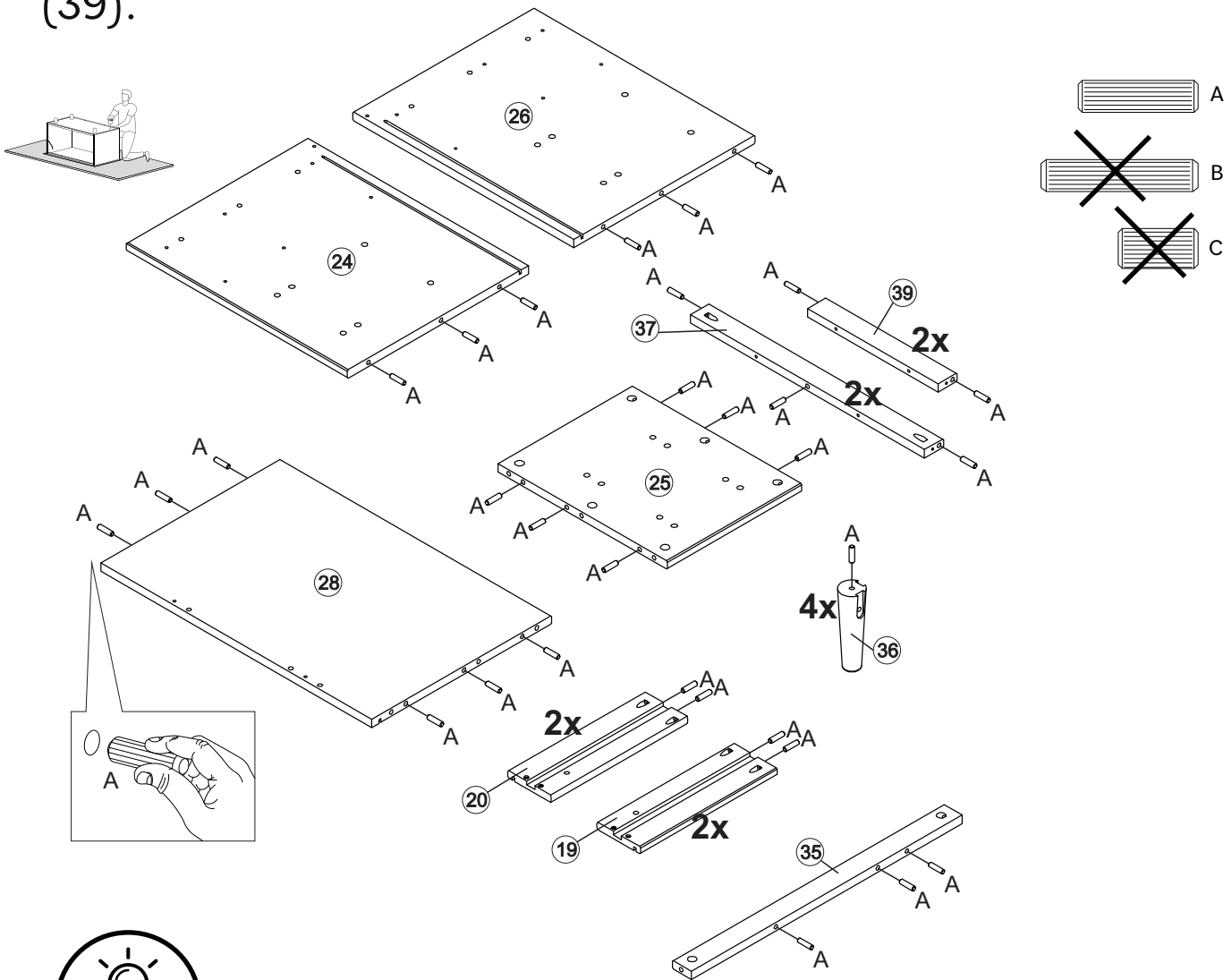

Tip

To keep your product looking its best and scratch-free, try assembling it on a soft surface like carpet or a blanket. This helps prevent any accidental scratches and keeps your furniture in top shape!

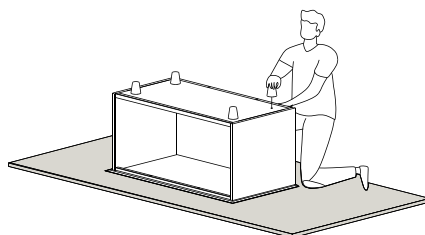

Step 3

Attach Cam Bolt (H), according to the diagram, on Left Side Panel (24), Right Side Panel (26), Shelf (29) and Base Panel (32) using a Phillips Head Screwdriver.

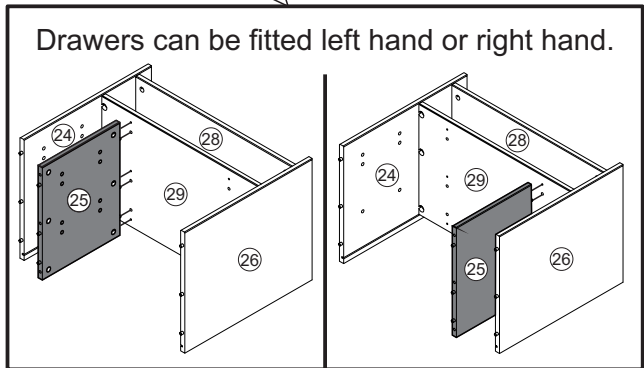
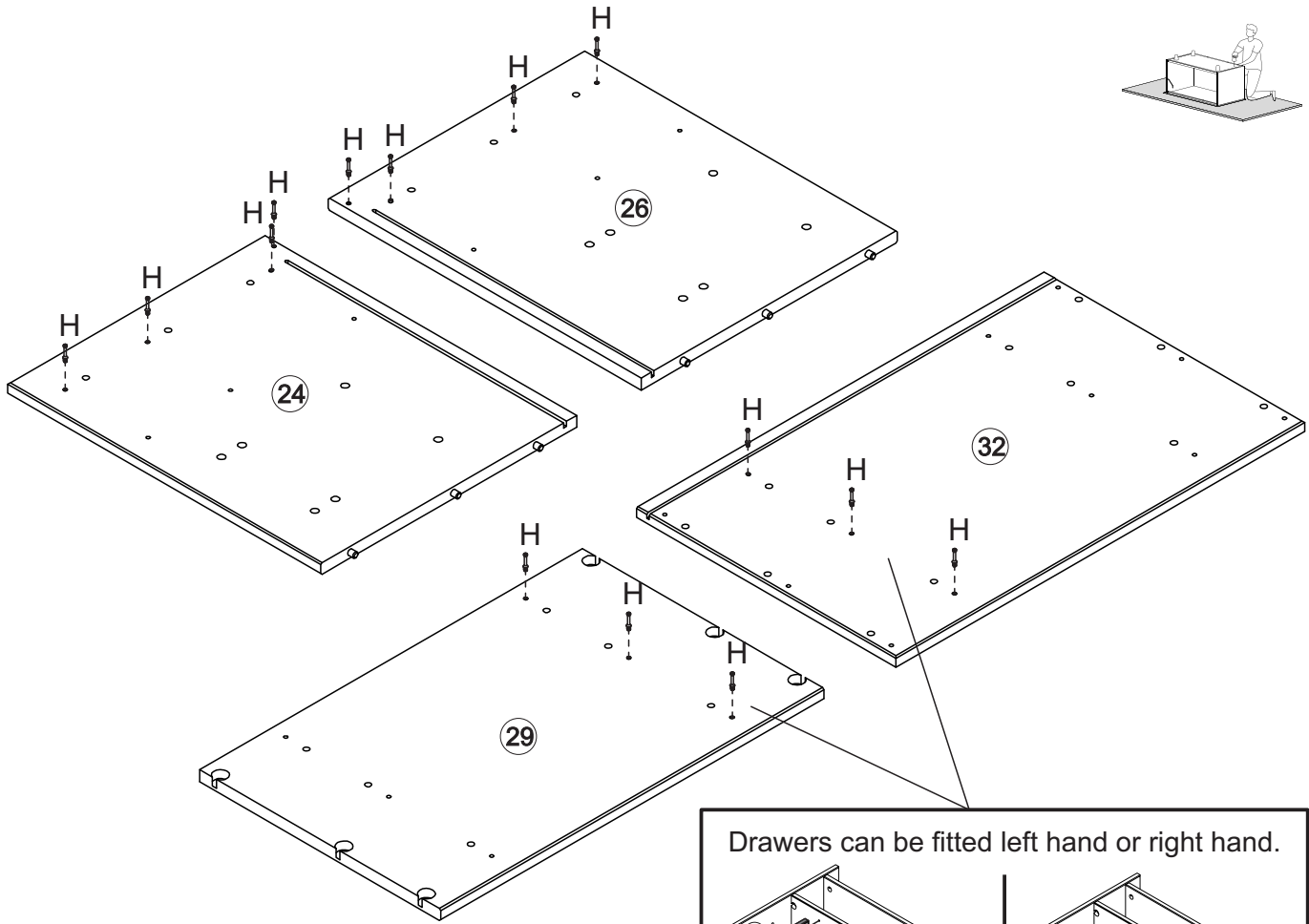

WARNING!
Assembly instruction shows drawers in the right side

Step 4

Do the same to Cam Bolts (K) on Left Side Panel (24) and Right Side Panel (26) using a Phillips Head Screwdriver.

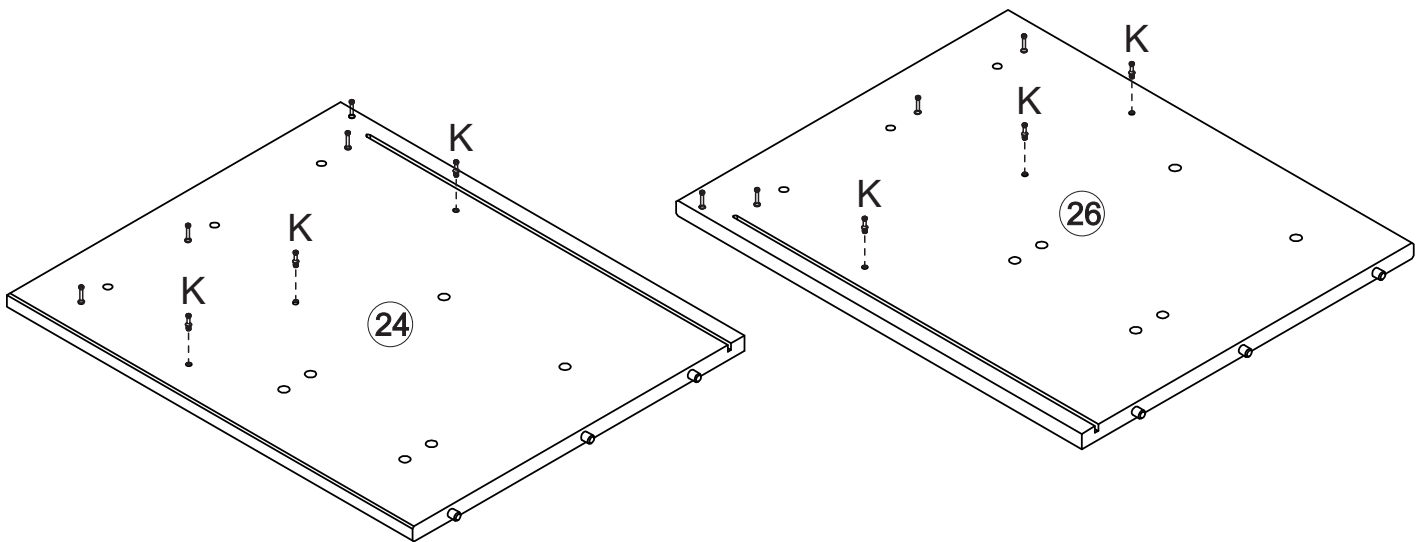

Step 5

Secure Wood Sliders (17) to Division (25) and Right Side Panel (26) using Screws (E) and a Phillips Head Screwdriver.

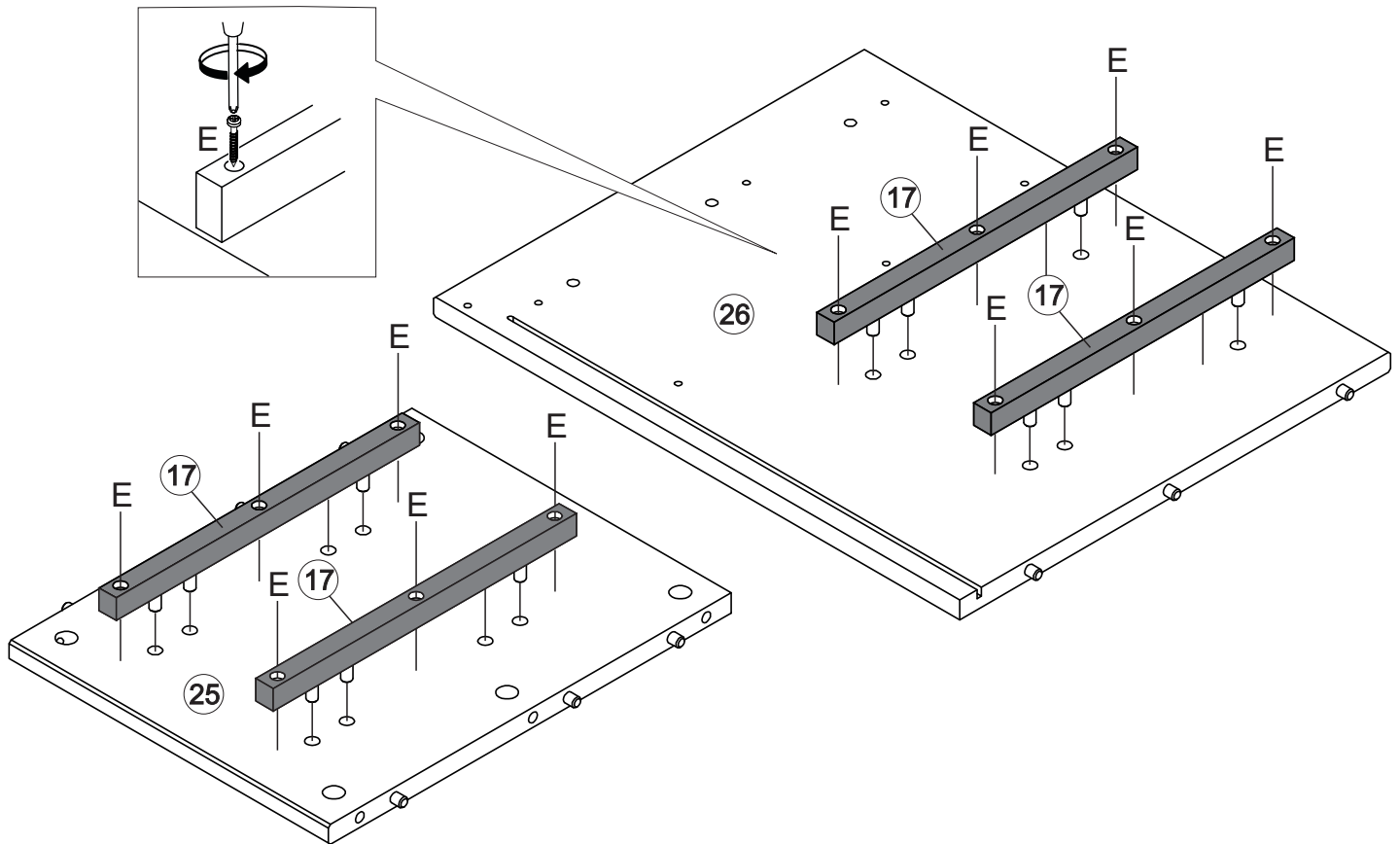
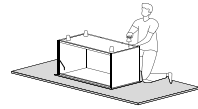

Step 6

Secure Top Crossbeam (35) to Top (28) using Screw (F) and a Phillips Head Screwdriver.

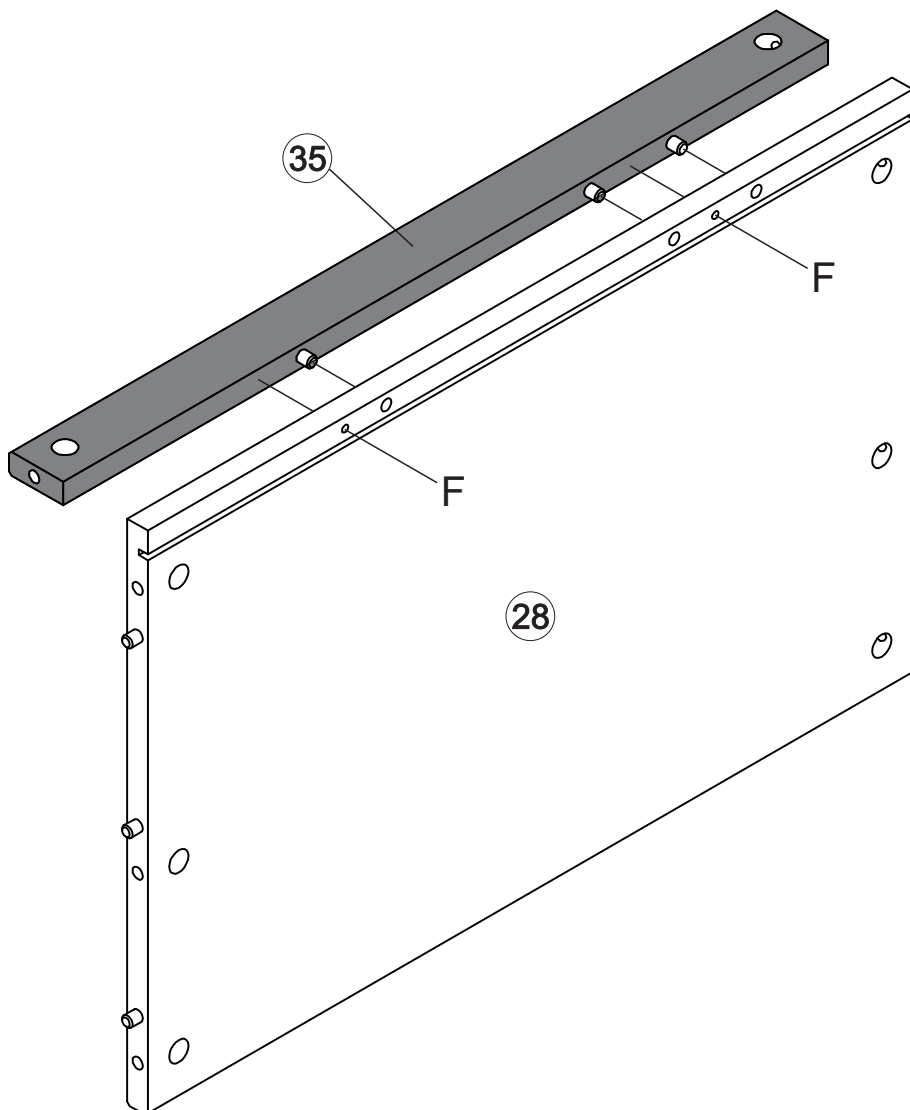
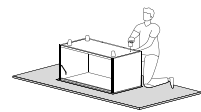

Step 7

Assemble Left Side Panel (24) and Right Side Panel (26) to Top (28) fitting Cam Bolts (H) and attaching Cam Locks (I) using a Phillips Head Screwdriver.

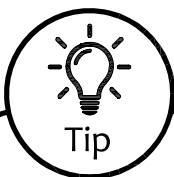
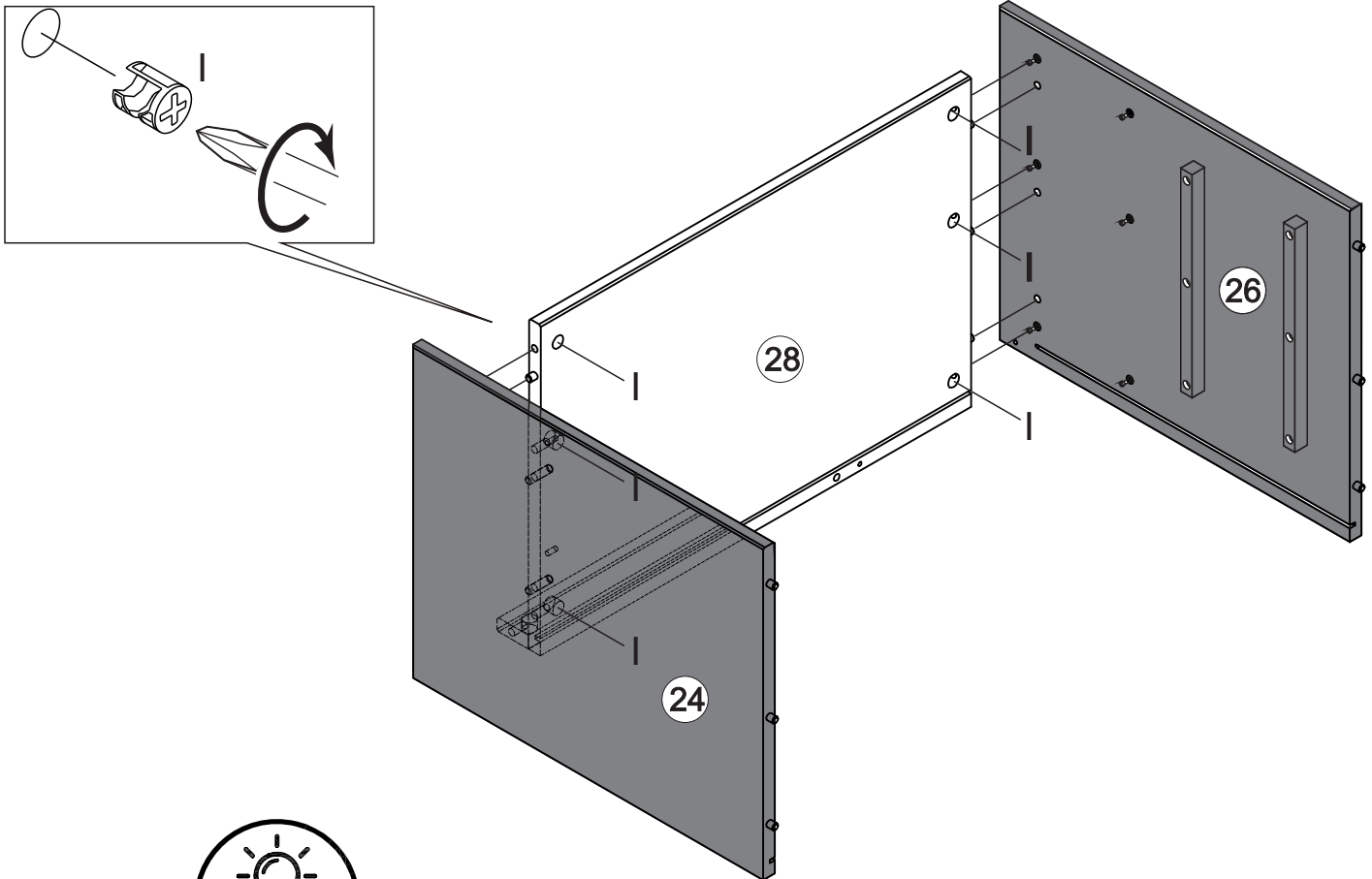

Tip

Cam Locks

Cam Locks help securely join two pieces together.
Follow these easy steps.

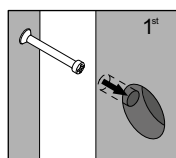

1: Insert Cam Bolt into bolt holes on the flat side. Don't over tighten!

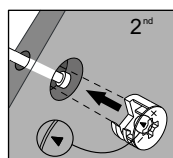

2: Assemble both parts together. The cam bolts goes in the drills holes that have a circular hole on the side, you should be able to see the cam bolt through it. After fitting parts together insert the cam lock on the side holes.

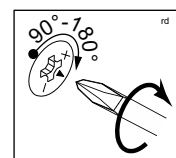

3: On the back of the Cam Lock will be a "C" shape. Insert the Cam Lock so the opening of the "C" fits over the Cam Bolt. Tighten with the screwdriver.

Step 8

Insert Plastic Lock (L) into Shelf (29) using a Hammer if necessary.

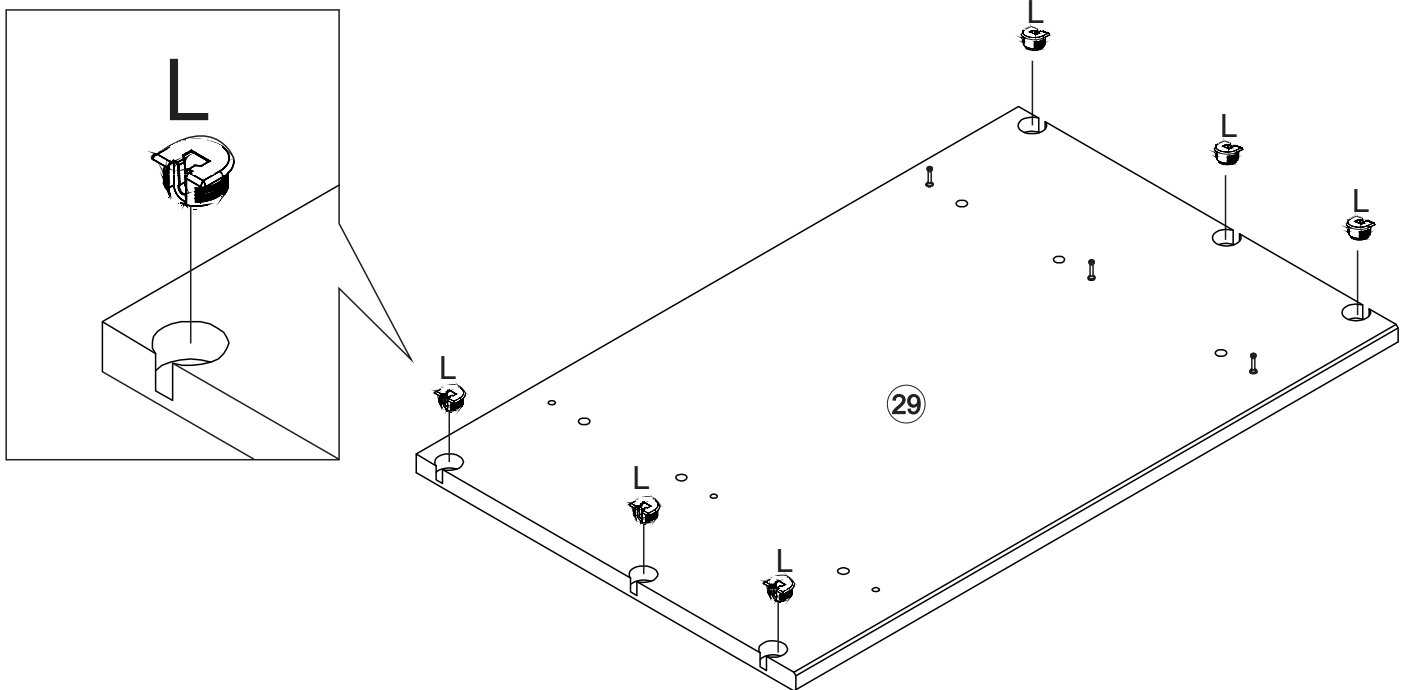

Step 9

Secure Division (25) to Shelf (29) using Cam Lock (I) and a Phillips Head Screwdriver.

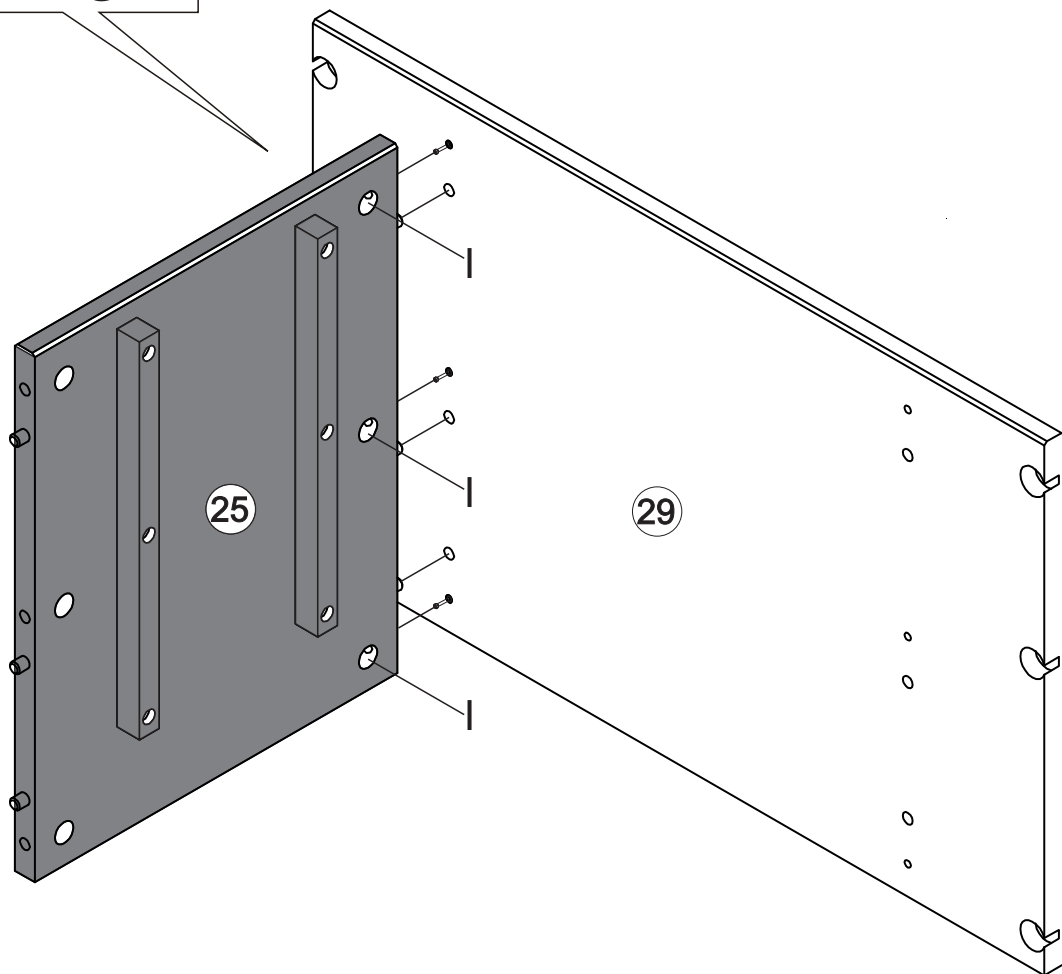
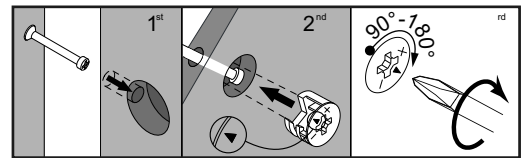
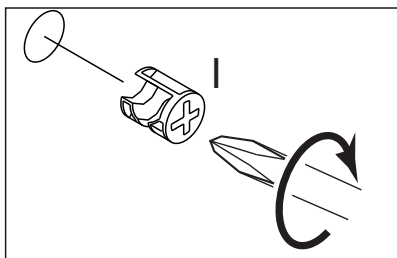
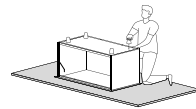

Step 10

Fit Division (25) and Shelf (29) over the pins. Align the pins on Left Side Panel (24) and Right Side Panel (26) inside the Plastic Lock (L).

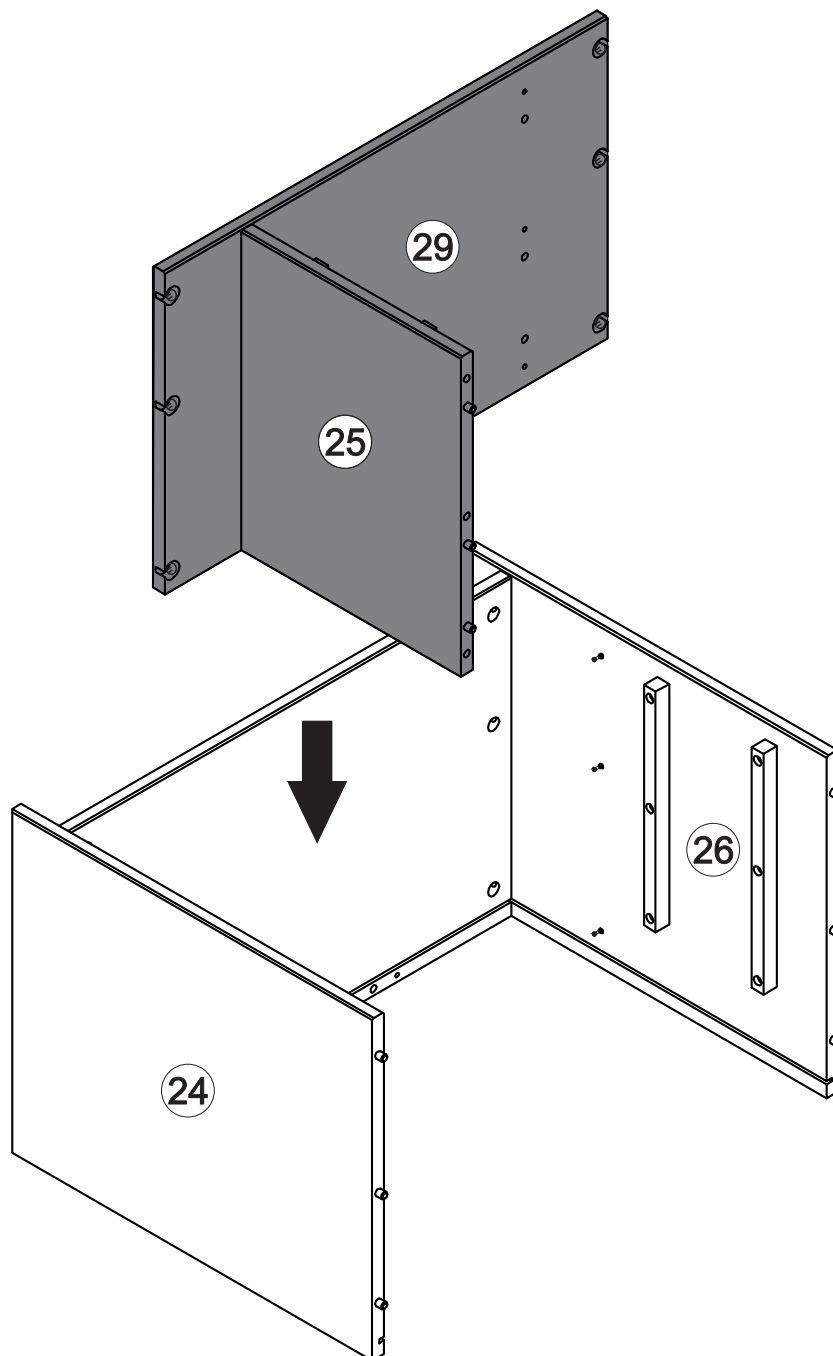

Step 11

Press until you feel the fit or "click".

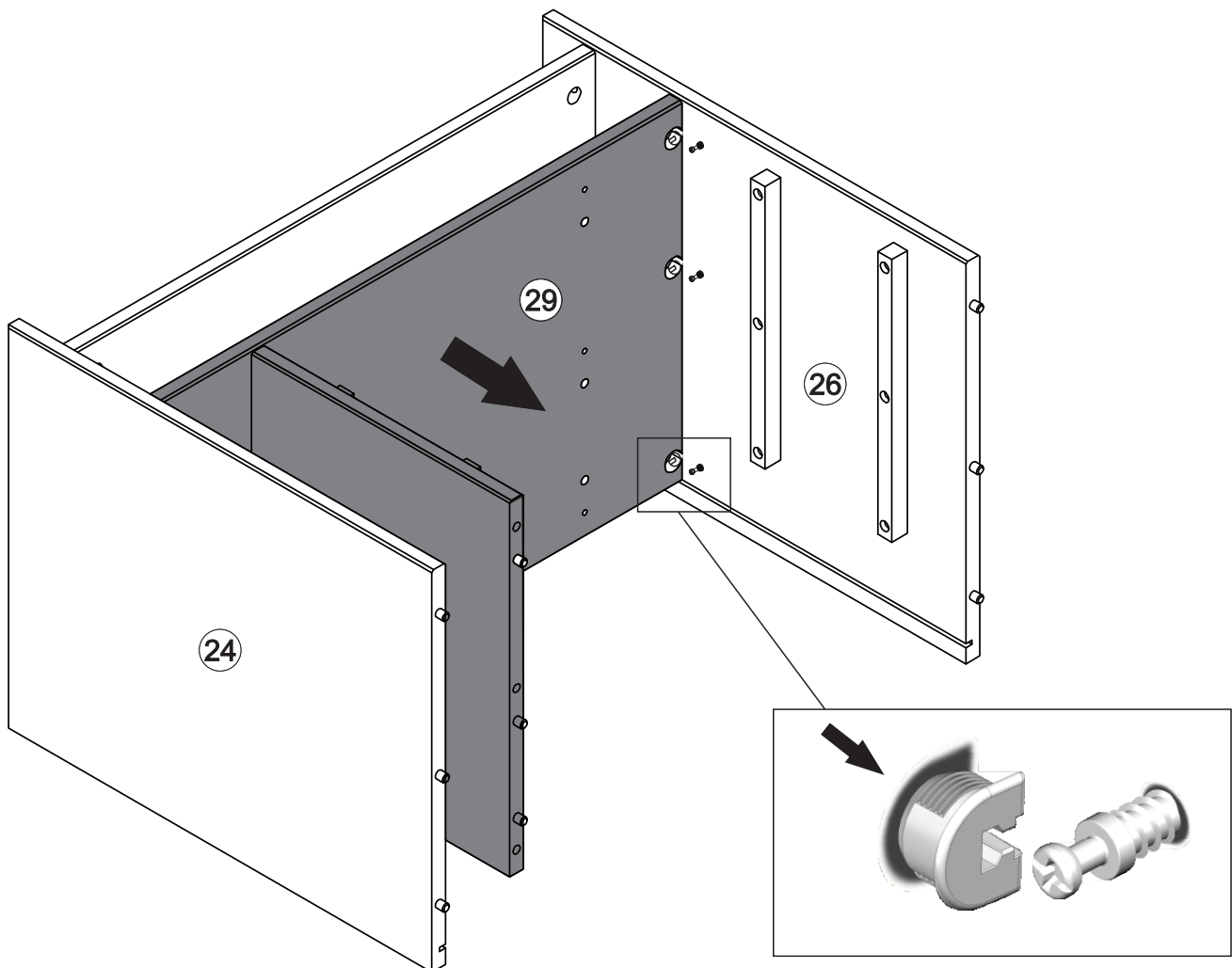
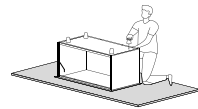

Step 12

Slide Back Panel (30) on the grooves on Left Side Panel (24) and Right Side Panel (26). Then attach Base Panel (32) using Screws (G) and a Phillips Head Screwdriver.

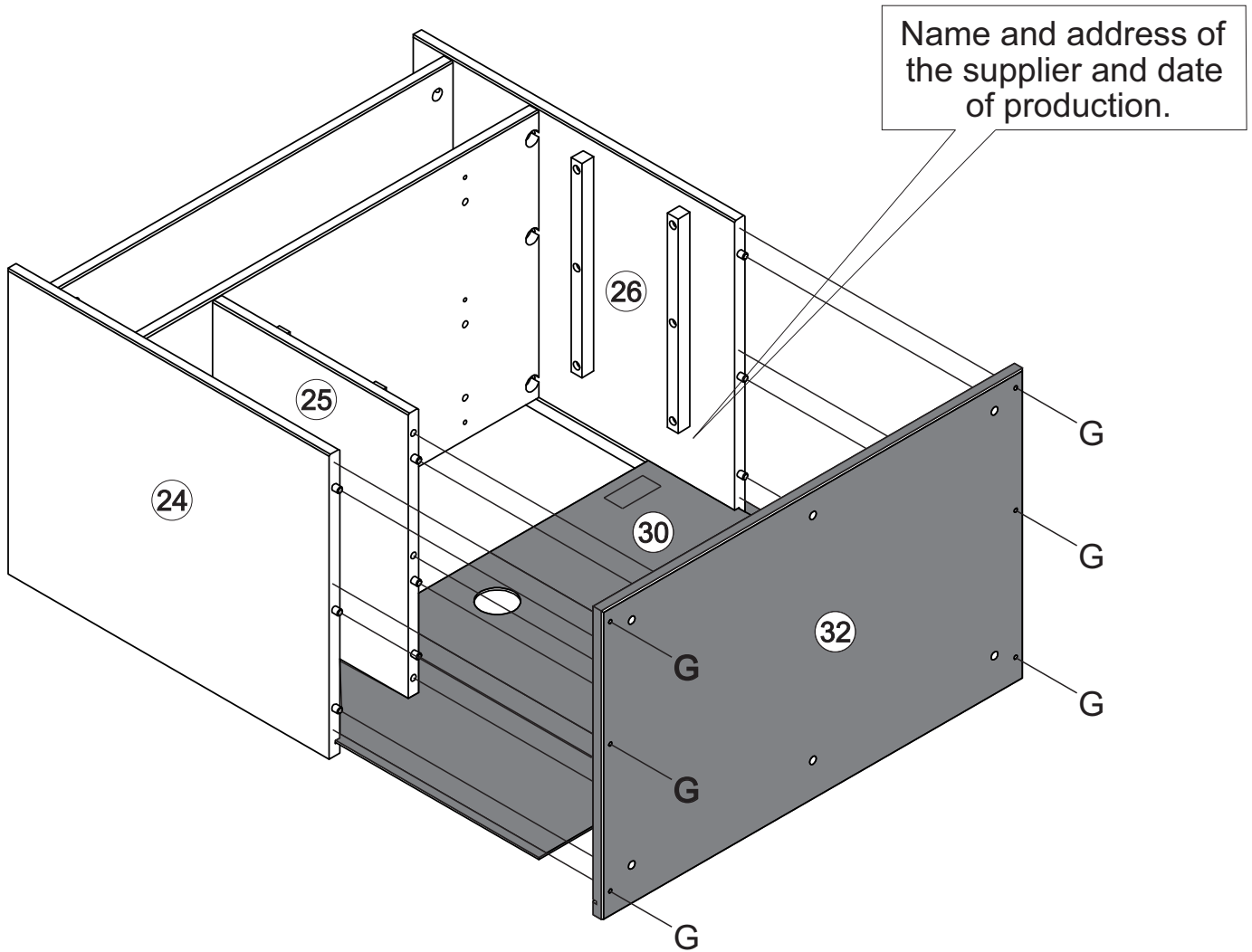

Step 13

Secure Base Panel (32) to Division (25) attaching Cam Lock (I) using a Phillips Head Screwdriver.

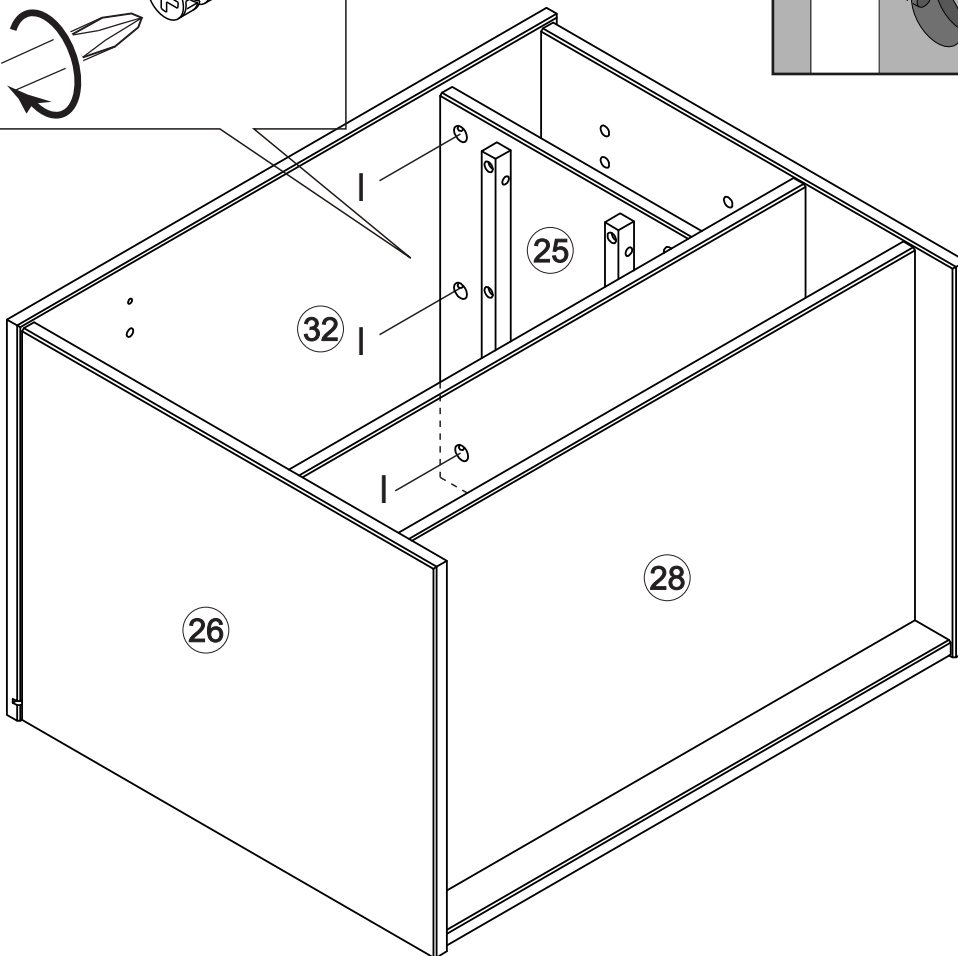
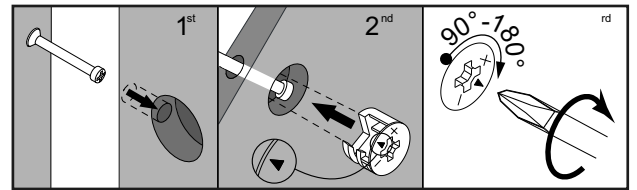
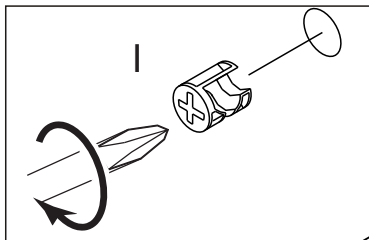

Step 14

Secure Bottom Front Crossbeam (37) to Foot (36) using Screws (G) and a Phillips Head Screwdriver.

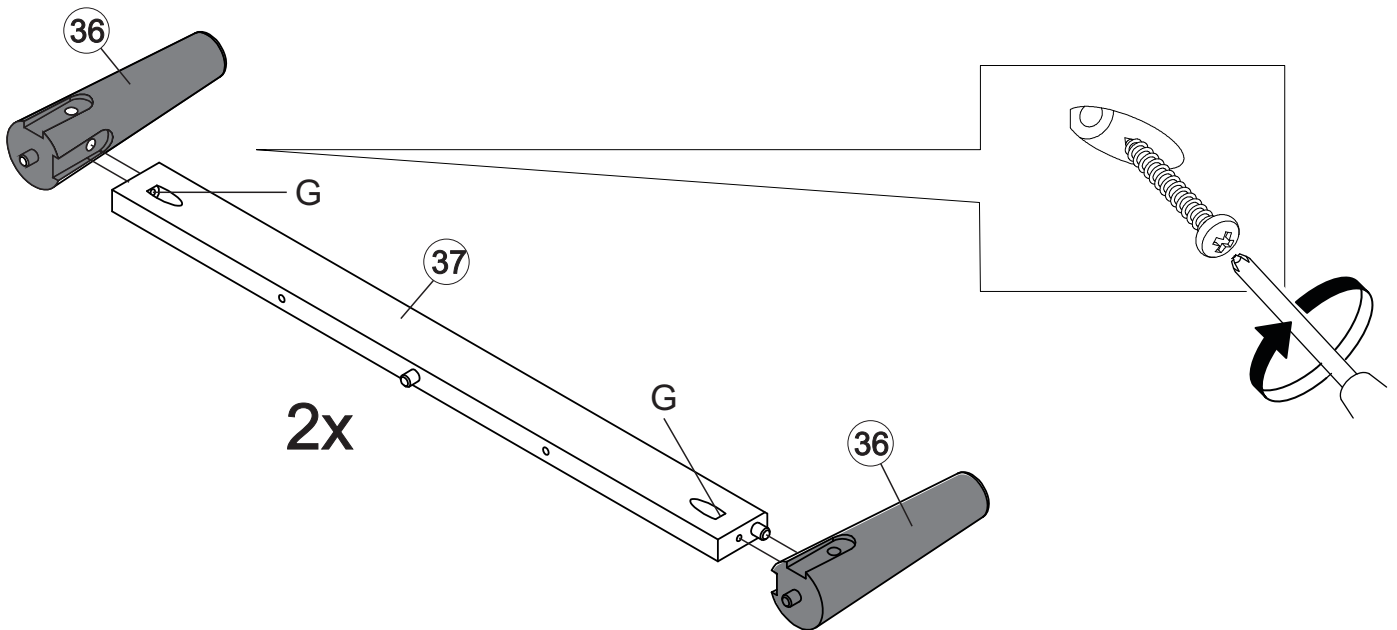

Step 15

Attach Bottom Side Crossbeam (39) to Foot (36) using Screws (G) and a Phillips Head Screwdriver.

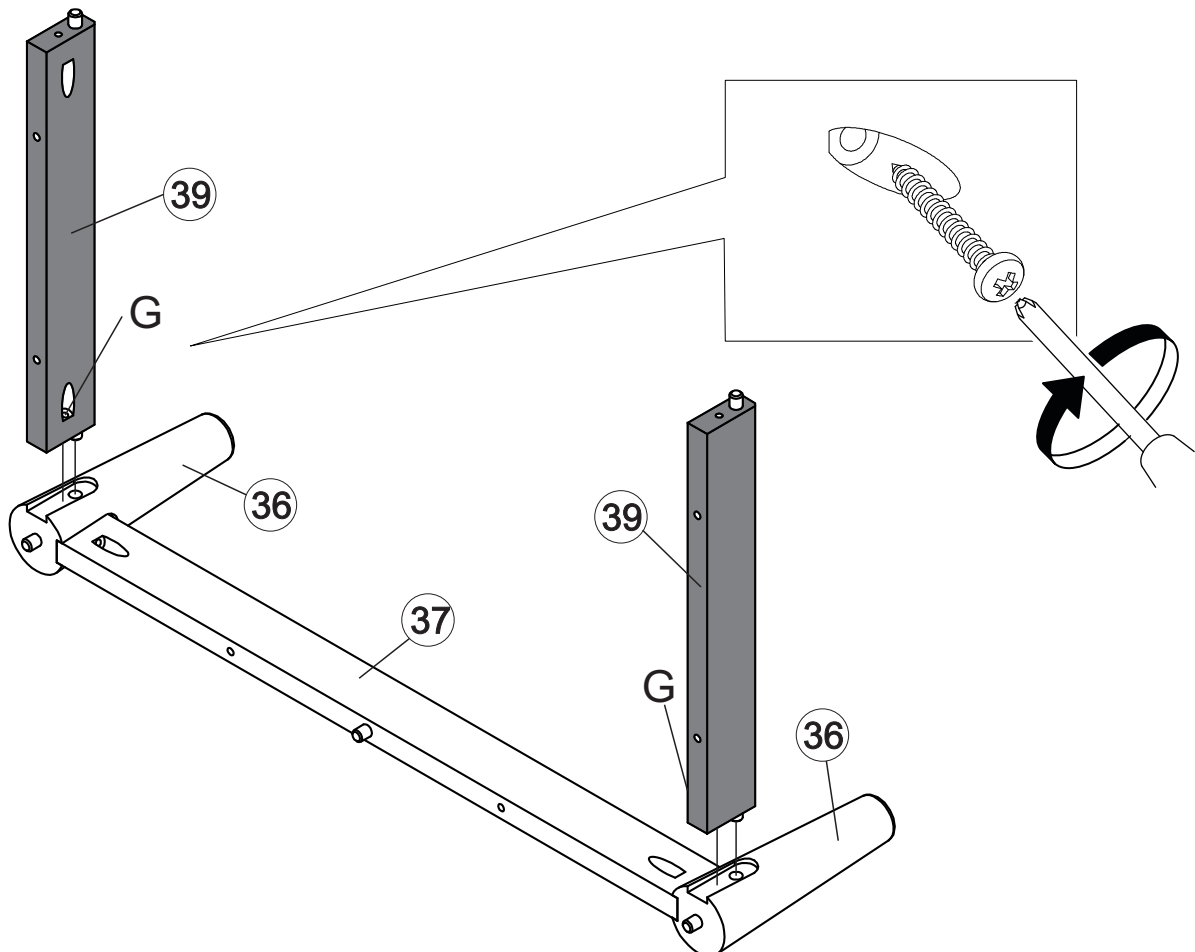
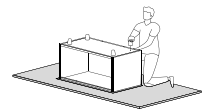

Step 16

To finish assembling the feet. Secure Bottom Side Crossbeam (39) to Foot (36) using Screws (G) and a Phillips Head Screwdriver.

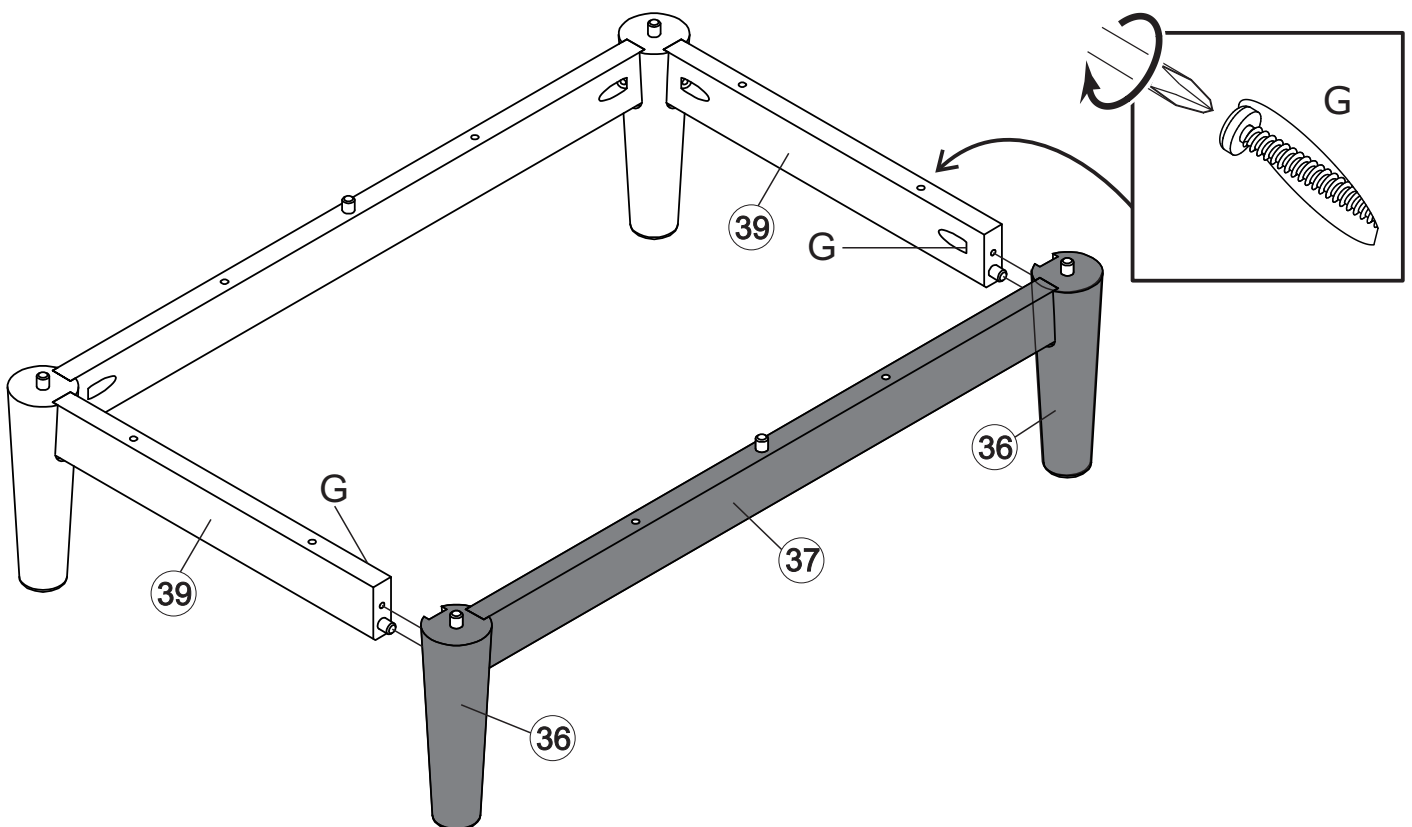

Step 17

Now, attach the assembled feet to Base Panel (32) using Screws (G) and a Phillips Head Screwdriver.

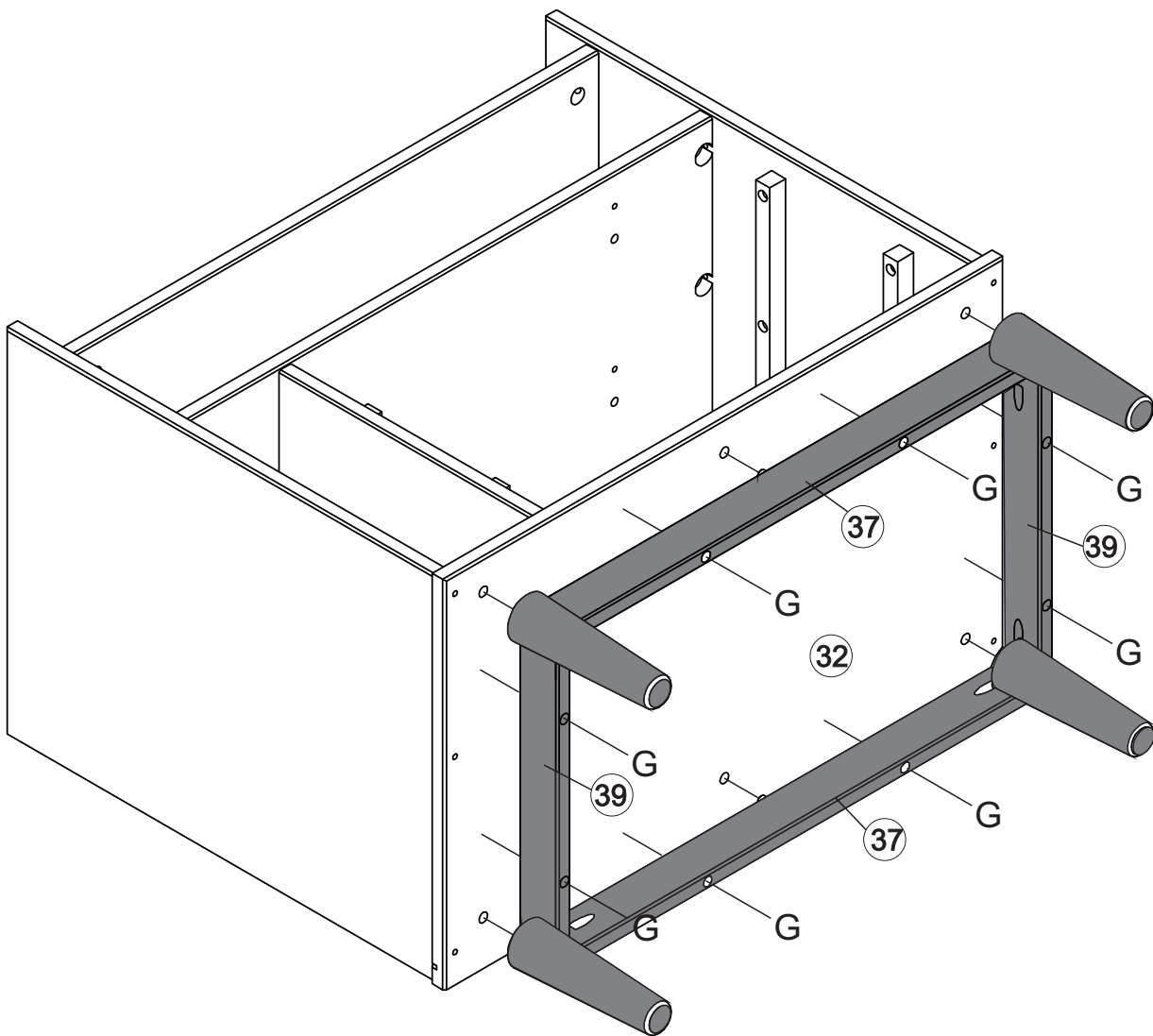

Step 18

Insert Wooden dowels (A) into Wood Sliders (17).

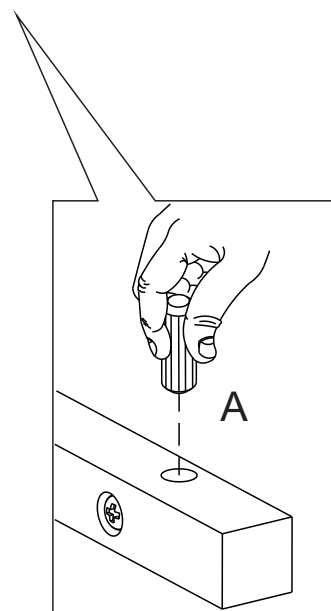
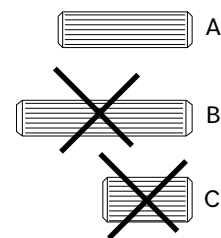
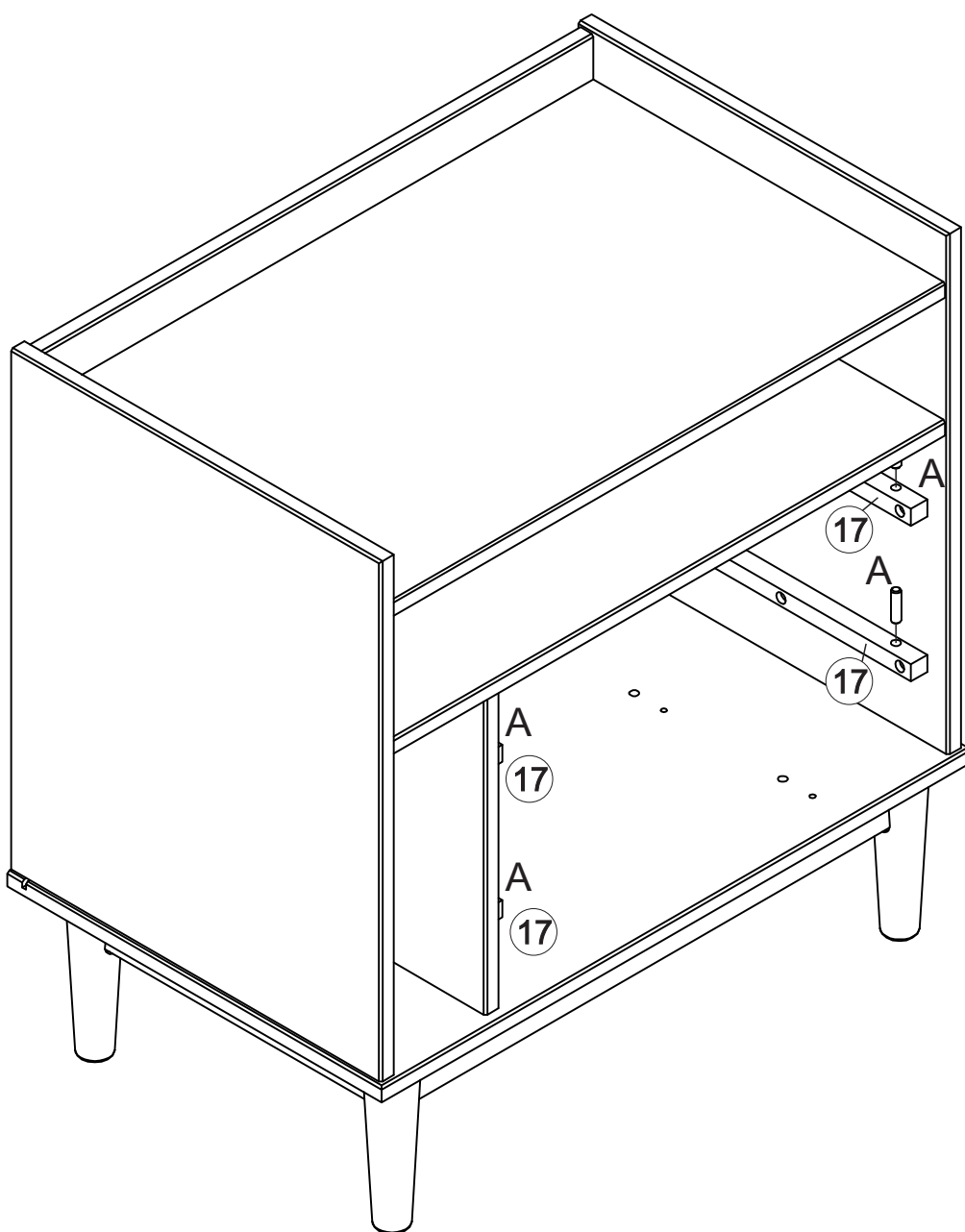

Step 19

Secure Right Drawer Side (19) and Left Drawer Side (20) to Drawer Front (6) using Screws (F) and a Phillips Head Screwdriver. Slide Drawer Bottom (23) on the grooves on Right and Left Drawer Sides (19,20) fitting in Drawer Front (6). Attach Drawer Back (21) to Right and Left Drawer Side (19,20) using Screws (F) and a Phillips Head Screwdriver.

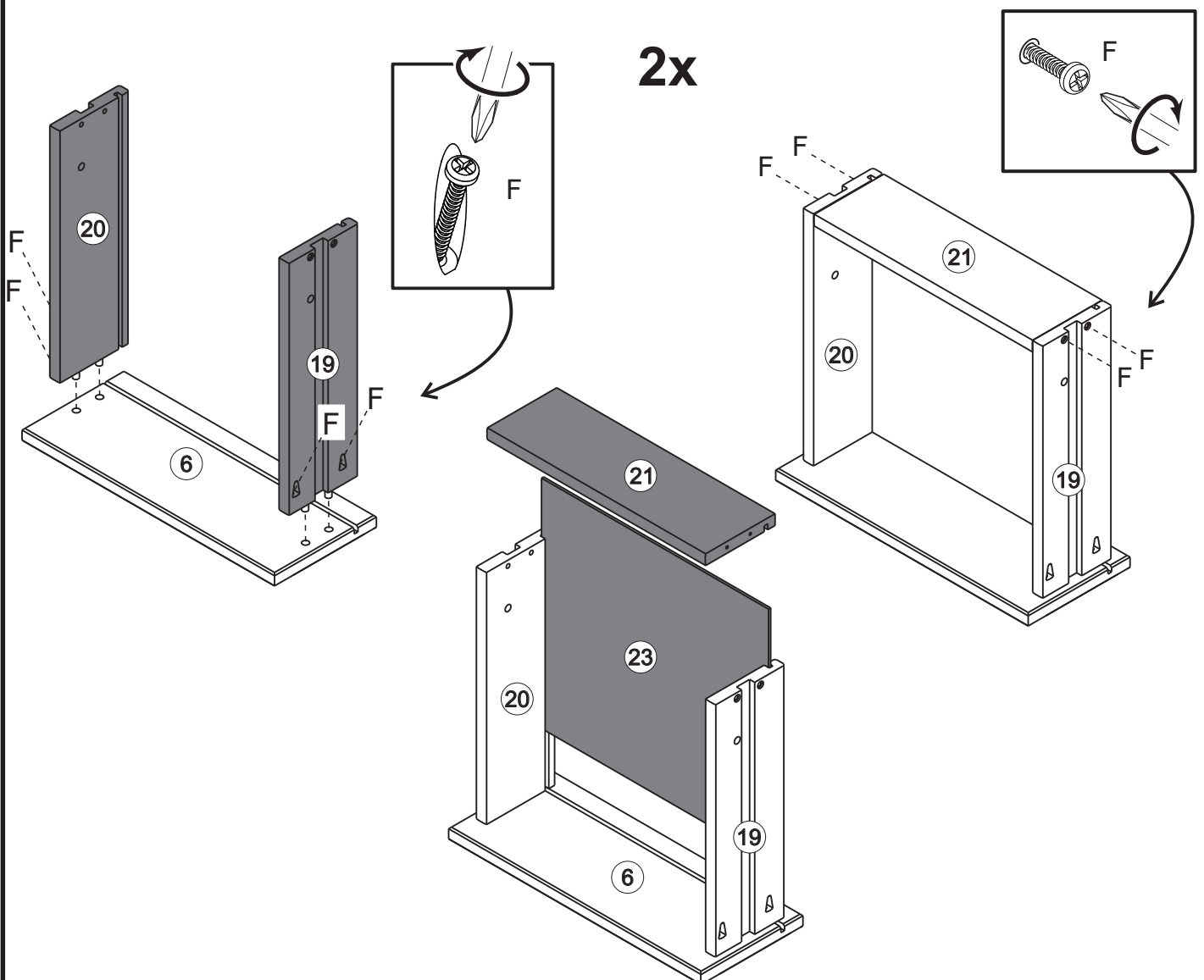

Step 20

Secure Handle (J) using Screws (D) and a Phillips Head Screwdriver in the pre drilled holes on the Drawer Front (6).



2x

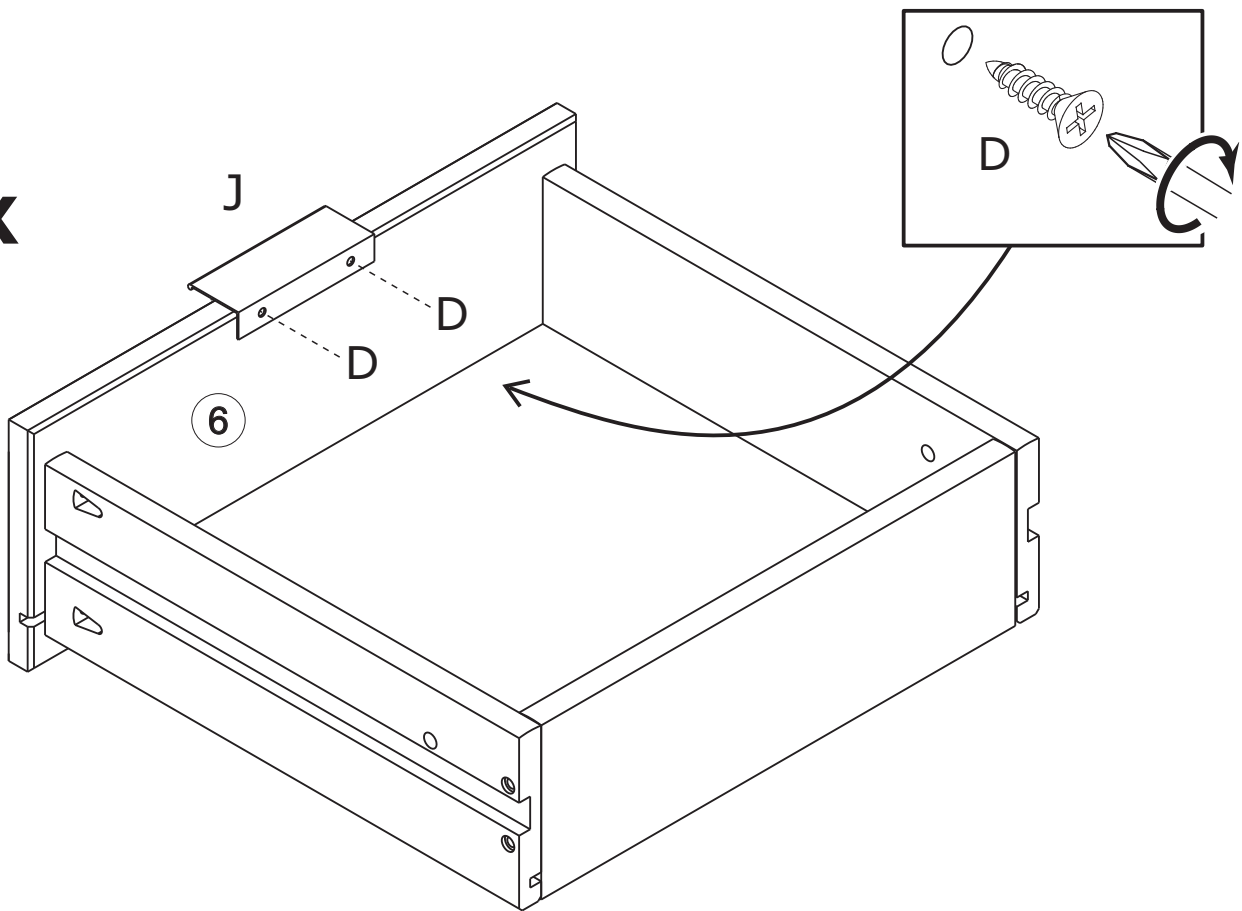

Step 21

Insert Wooden dowel (B) on the inside of all drawers, with the drawer inside the unit, after having passed the wooden dowel that is in the drawer slide. The dowel is not flush with the panel, it is a little inside the drawer to help when you need to remove the lock dowel to remove the drawer.

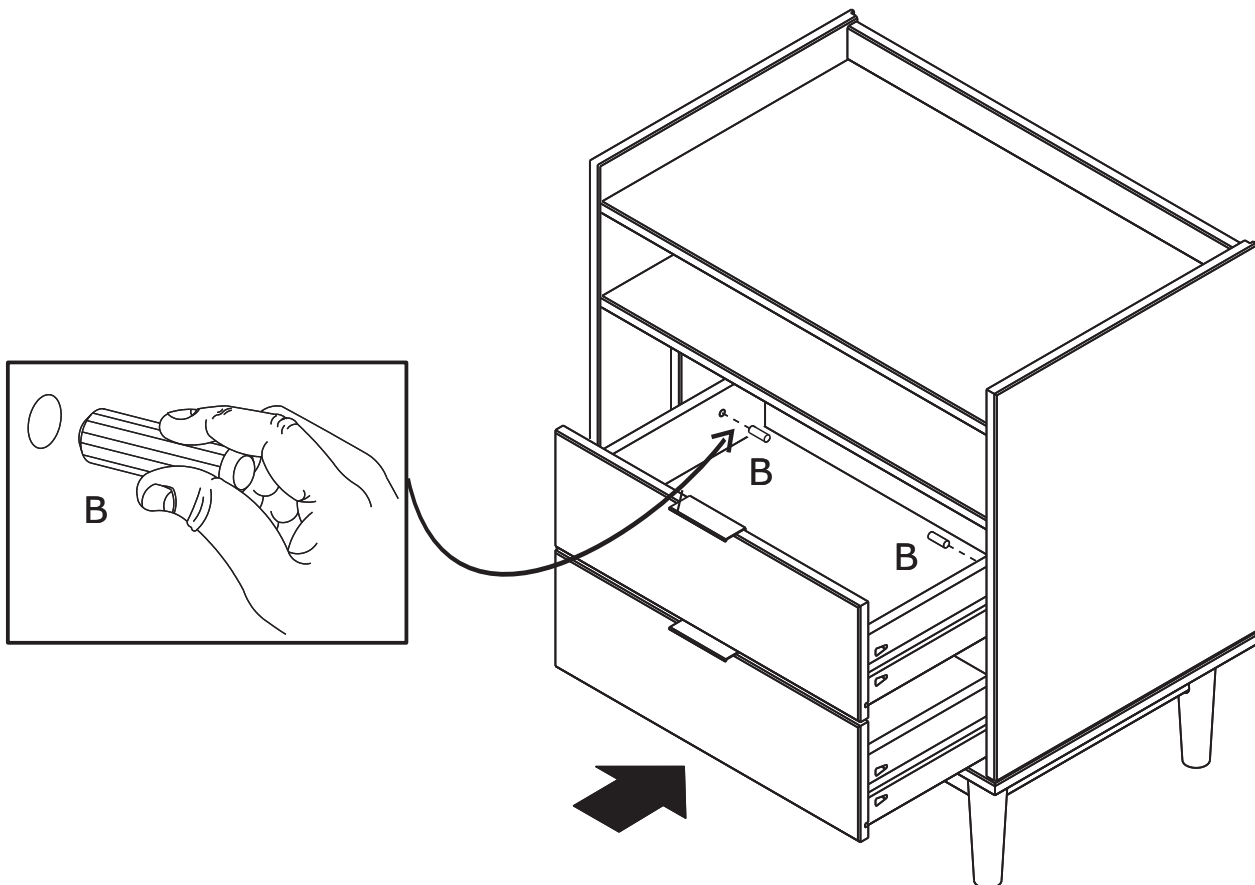
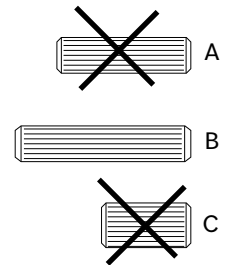

Step 22

Insert the slap hole (M) into the niche.

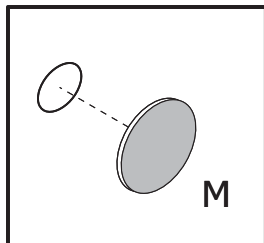
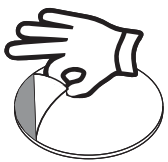

There are colors options for the slaps, choose the slap according to the color of your item.

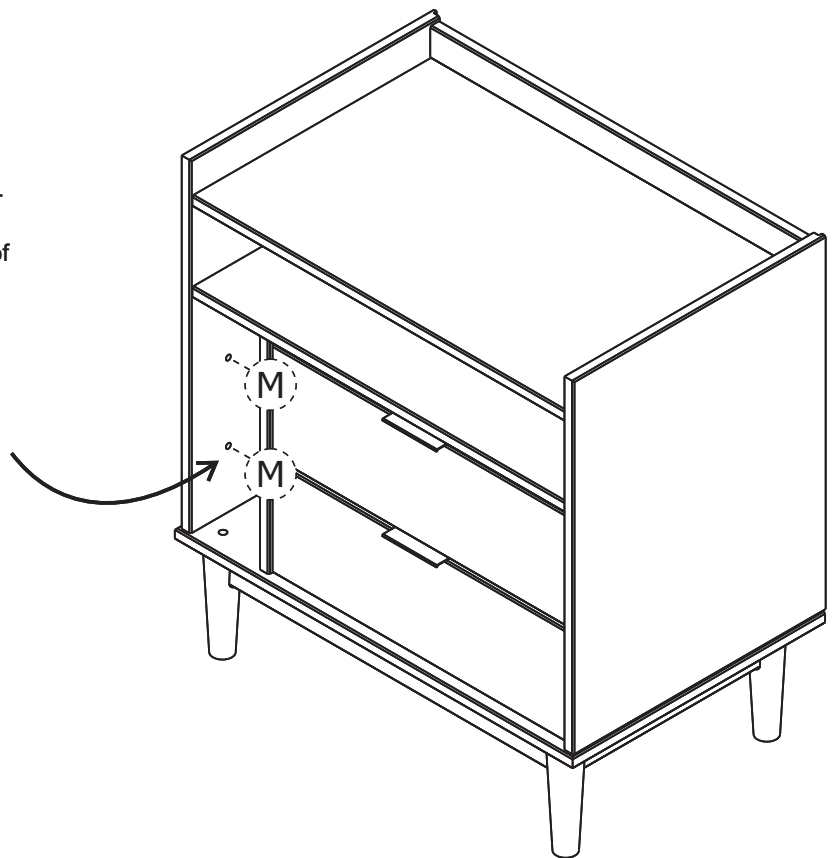

Step 23

Secure Top Crossbeam (35) to Left Side Panel (24) and Right Side Panel (26) using Cam Lock (I) and Phillips Head Screwdriver.

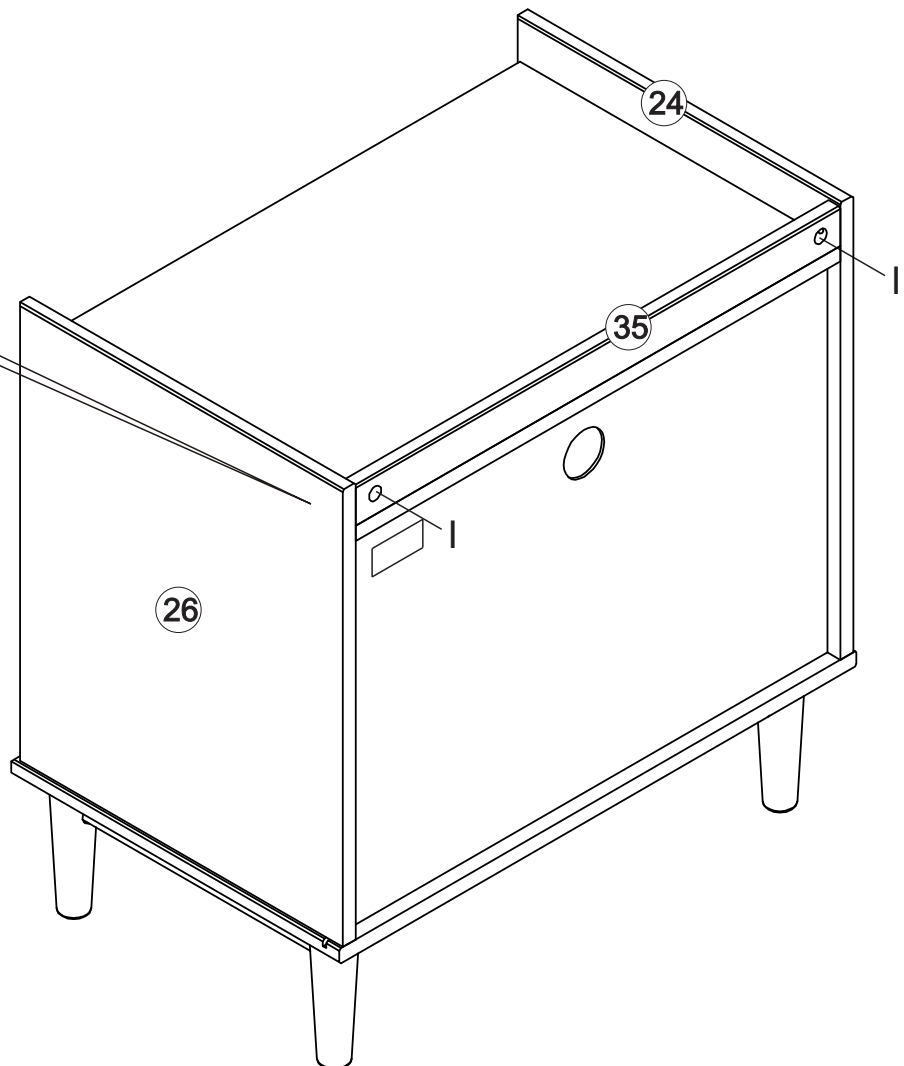
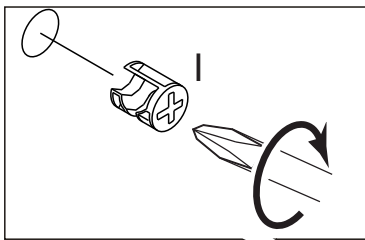
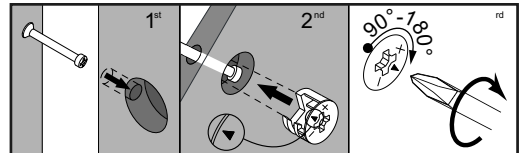

You did it! Enjoy your new Night Stand!

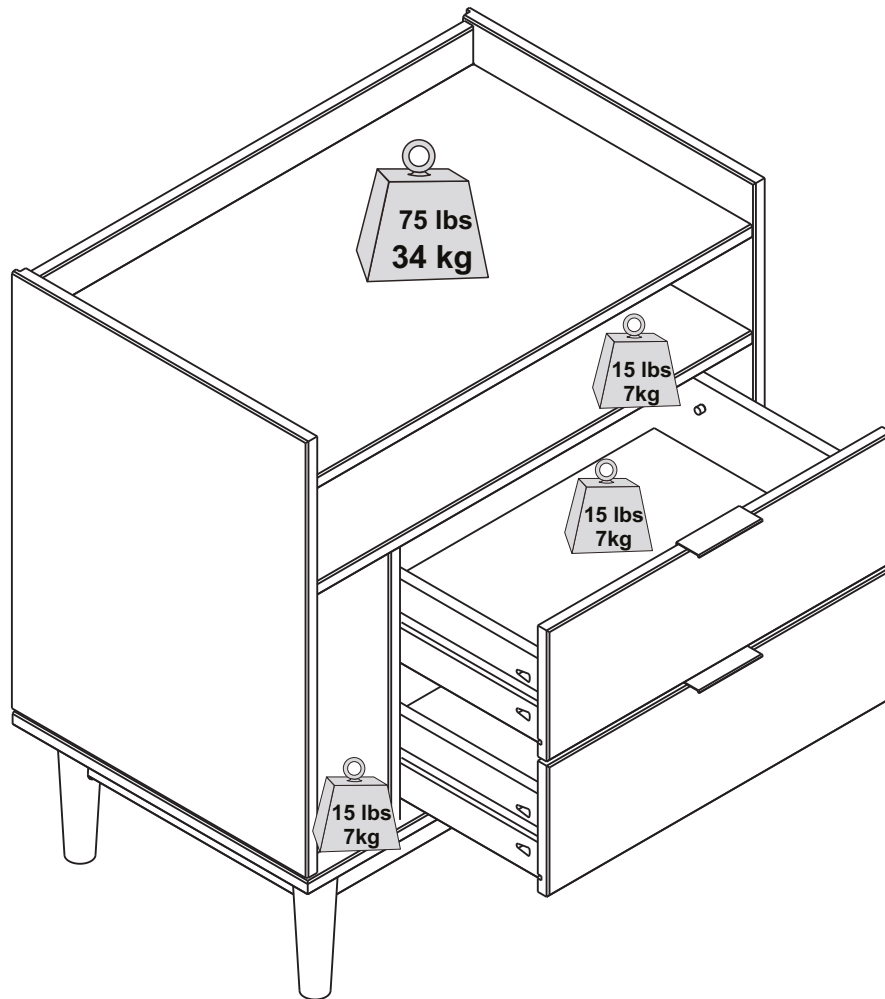

Congratulations on you new piece of furniture!
We would love to hear about it and see it.
Please leave us a review or post a picture with
[#mywalkerredisonhome](https://www.instagram.com/mywalkerredisonhome)

Assembling furniture can be tricky sometimes.

Our customer service team, located in Utah, is here for product information, help assembling a product, or for any other customer support issue

Call us at **801-433-3008**

Email us at service@walkeredison.com

Visit our Customer Service website at walkeredison.com/pages/customer-service

We are available to help Monday-Thursday 8am-5pm, Friday 8am-3pm MST

For details on Assembly Videos, Assembly Instructions, Replacement Parts, and Customer service,

SCAN HERE

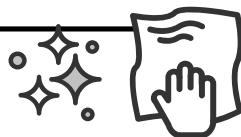

For cleaning, never use abrasives, use a soft cloth and water with neutral soap to clean the furniture.

WALKER EDISON

TM

Lee Table de Chevet Moderne en
Bois du Milieu du Siècle
Lee Mesita de Noche Moderna de
Mediados de Siglo em Madera



Pour usage résidentiel seulement

Visite notre site Web pour obtenir les instructions les plus récentes, des conseils d'assemblage, signaler des dommages ou commander des pièces. www.walkerredison.com

Sólo para uso residencial

Visite nuestro sitio web para consultar las últimas instrucciones, consejos de montaje, notificar daños o solicitar piezas. www.walkerredison.com

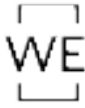

Il est temps de commencer / Hora de empezar

Prépare un lieu de travail propre et souple pour éviter tout dommage lors de l'assemblage. Tu peux utiliser la boîte et les protections internes comme base. Vérifie également que tu disposes de toutes les pièces et parties avant de te lancer dans l'assemblage.

Prepare un lugar de trabajo limpio y blando para evitar daños durante el montaje. Puede utilizar la caja y las protecciones internas como base. Comprueba también que tiene todas las piezas y partes antes de sumergirse en el montaje.

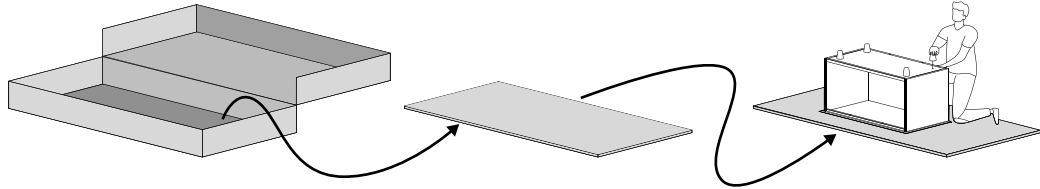

**Temps de montage
estimé**
**Tiempo estimado de
montaje**

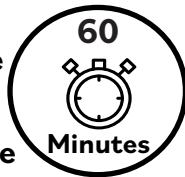

2 Personnes
2 Personas

Personnes recommandées pour le montage

Fais-en un effort d'équipe !
Appelle un ami pour un
assemblage plus rapide et plus
facile.

Personas recomendadas para el montaje

¡Hágalo en equipo!
Llame a un amigo para que el
montaje sea más rápido y sencillo.

Outils nécessaires

Munis-toi d'un tournevis cruciforme pour réaliser cet assemblage. Tu auras également besoin d'un marteau pour t'aider.

Herramientas requeridas

Tome un destornillador Phillips pour conquister este conjunto. También necesitaremos un martillo para ayudar.

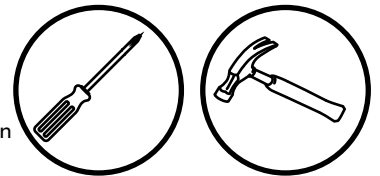

Utilise les outils électriques avec précaution

Ce meuble est réalisé en Bois Massif et Bois Composite, des matériaux souples. Si tu choisis d'utiliser des outils électriques, règle-les sur le mode le plus lent. Fais attention à toi ! Les outils électriques peuvent provoquer des fissures ou endommager les meubles, mais aussi les autres composants s'ils sont mal utilisés. Les dommages causés par un outil électrique ne sont pas couverts par la garantie Walker Edison.

Utilice las herramientas eléctricas con cuidado.

Este mueble está fabricado con madera maciza y madera compuesta, materiales blandos. Si decide utilizar herramientas eléctricas, ajústelas al ajuste más lento. Tenga cuidado. Las herramientas eléctricas pueden causar grietas o daños en el mueble, pero también en los herrajes si se utilizan mal.

Los daños causados por una herramienta eléctrica no están cubiertos por la garantía de Walker Edison.

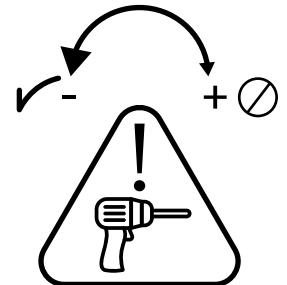

Attention avec la glissière

Tes meubles possèdent des glissières en bois très résistantes. De temps en temps, nous recommandons d'appliquer de la paraffine ou de la cire de bougie standard pour améliorer la glisse des curseurs.

Cuidado con las guías

Tus muebles cuentan con guías de madera de alta durabilidad. De vez en cuando, recomendamos la aplicación de parafina o cera estándar para mejorar el deslizamiento de los deslizadores.

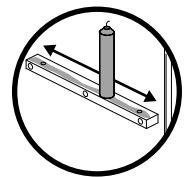

Scannez pour obtenir des conseils d'assemblage et de l'aide !
¡Escanee para obtener consejos de montaje y ayuda!

Nombre de pièces
Número de pieza

Description
Descripción

Quantité
Cantidad

6	Façade du tiroir Frente del Cajón	2
17	Glissières en Bois Correderas de Madera	4
19	Côté Droit du tiroir Lado Derecho del Cajón	2
20	Côté Gauche du tiroir Lado Derecho del Cajón	2
21	Arrière du tiroir Parte Trasera del Cajón	2
23	Fond du tiroir Fondo del Cajón	2
24	Panneau Gauche Panel Izquierdo	1
25	Panneau Central Panel Central	1
26	Panneau Droit Panel Derecho	1

Nombre de pièces
Número de pieza







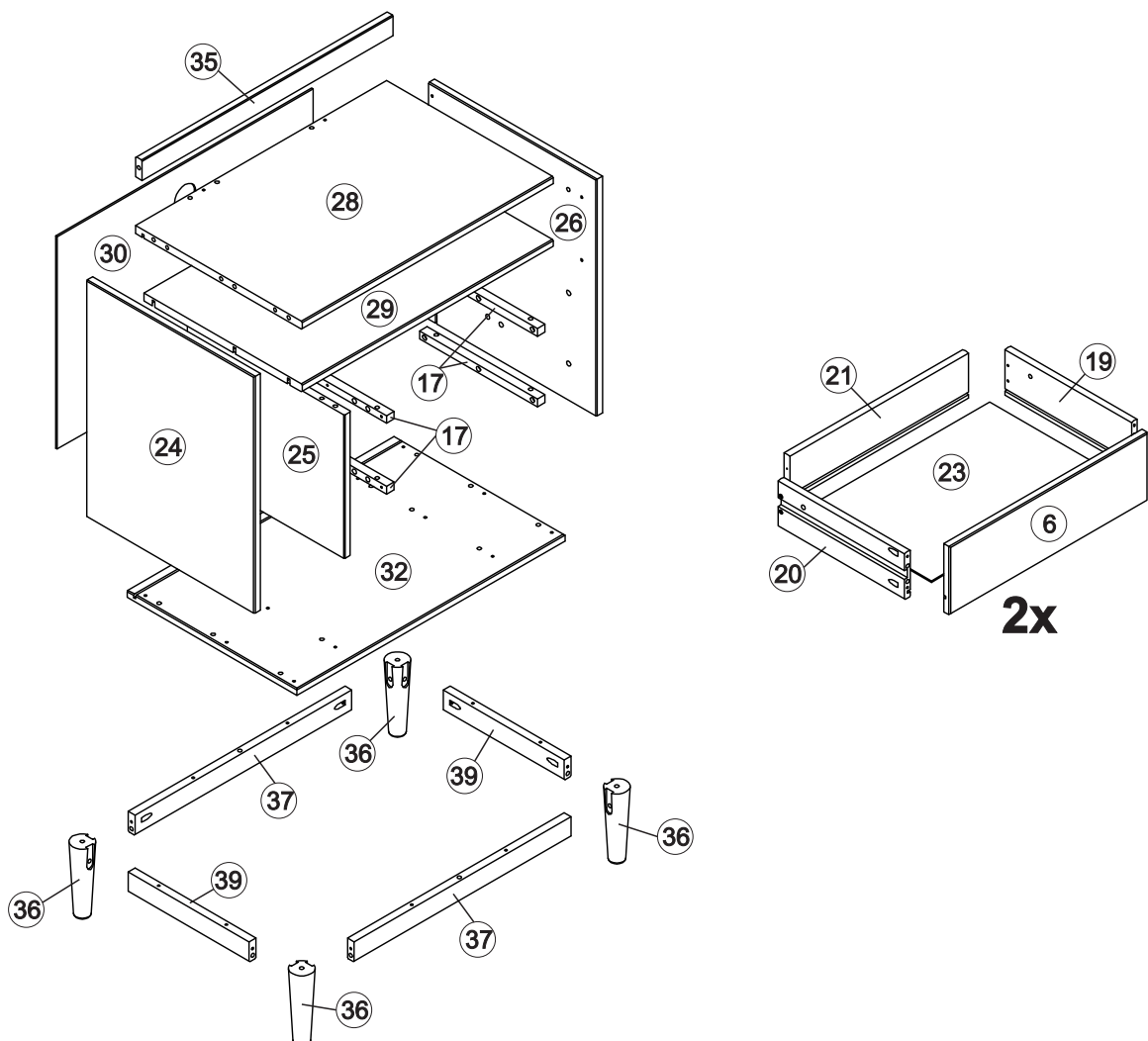

Description
Descripción

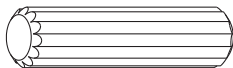
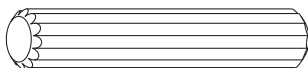
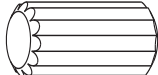
Quantité
Cantidad

28	Panneau Supérieur Panel Superior	1
29	Étagère Repisa	1
30	Panneau arrière Panel inferior	1
32	Panneau inférieur Panel Inferior	1
35	Barre supérieure Travesaño superior	1
36	Pied Pie	4
37	Traverse Avant Inférieur Travesaño Delantero Inferior	2
39	Traverse Latérale Inférieur Travesaño Lateral Inferior	2

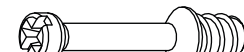

Liste de composants / Lista de hardware

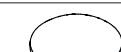
	Parte Parte	Taille Tamaño	Nom Nombre	Quantité Cantidad
A		Ø8*30mm	Cheville en bois Espiga de madera	47
B		Ø8*40mm	Cheville en bois Espiga de madera	04
C		Ø10*20mm	Cheville en bois Espiga de madera	12
D		Ø3,0*12mm	Vis Tornillo	04
E		Ø4,0*25mm	Vis Tornillo	12
F		Ø3,5*30mm	Vis Tornillo	18
G		Ø4,0*40mm	Vis Tornillo	22
H		ø15*30mm	Goujon de Assemblage Conector	14
I		ø15*10mm	Boitier de Assemblage Traba del Conector	14
J			Poignée Manija	02
K		Ø8*8mm	Goujon de Assemblage Conector	06
L		-	Verrou en Plastique Traba Plastica	06
M			Cache-trou Tapa agujero	06

Les quantités de composants indiquées ci-dessus sont nécessaires pour un assemblage correct.

Des pièces supplémentaires peuvent être incluses.

Las cantidades de tornillería indicadas anteriormente son necesarias para un montaje correcto.

Se pueden incluir piezas de ferretería adicionales.

Étape / Paso 1

(FR)

Commençons! La première étape consiste à insérer les Chevilles (C) dans les Glissières en Bois (17).

(ES)

¡Manos a la obra! El primer paso es insertar las Espigas (C) en las Correderas de Madera (17).

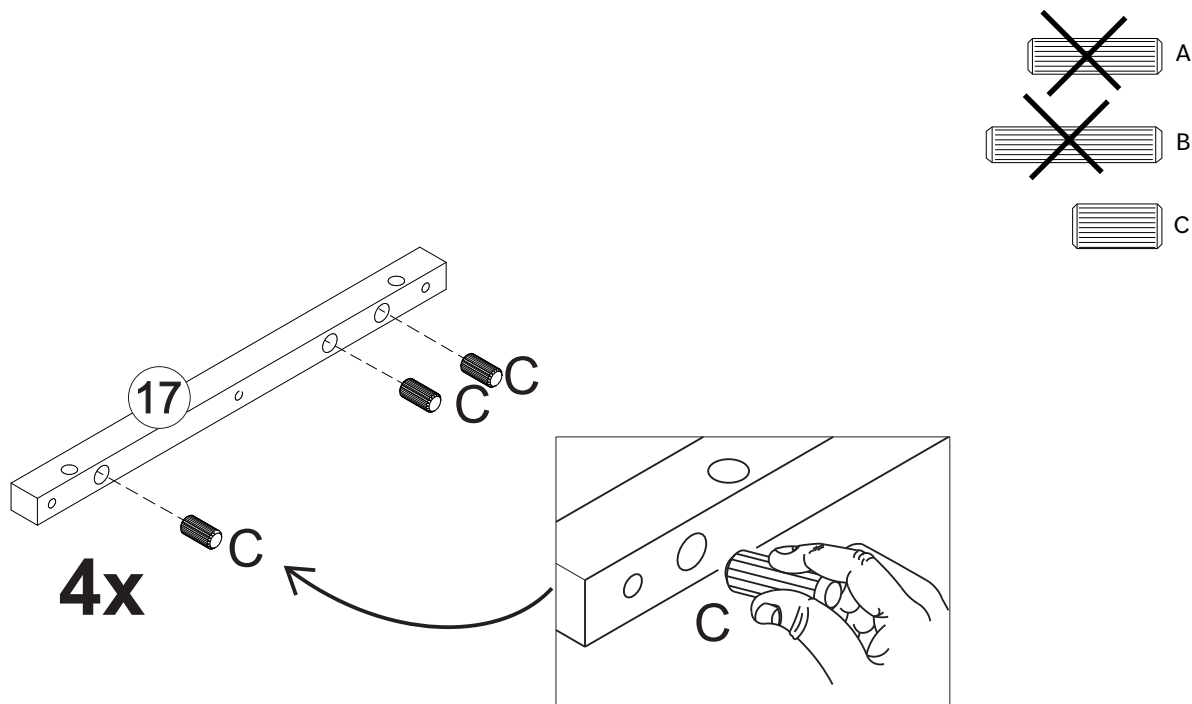

Cheville en bois

Les chevilles sont essentielles lors de l'assemblage de meubles pour créer des connexions solides et précises. Elles garantissent l'intégrité structurelle, empêchent les déplacements et simplifient l'alignement, ce qui permet d'obtenir des meubles plus résistants et plus durables. suis ces étapes :

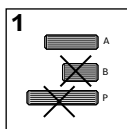

1: Sélectionne la taille de cheville appropriée en fonction de l'étape.
1: Seleccione el tamaño de espiga adecuado según el paso.

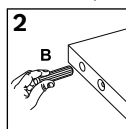

2: Insère dans le trou indiqué et appuie fermement pour assurer un positionnement correct.
2: Insértela en el orificio indicado y presione firmemente para asegurar su correcta colocación.

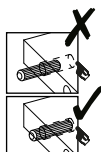

Sigue estos pasos:

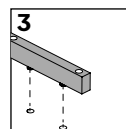

3: Alinee la cheville avec la pièce correspondante et enfonce-la jusqu'à ce qu'elle soit ferme.
3: Alinee el pasador con la pieza correspondiente y presiónelo hasta que encaje.

Étape / Paso 2

(FR)

Insère les Chevilles (A) dans le Côté Droit du Tiroir (19), Côté Gauche du Tiroir (20), Panneau Gauche (24), Panneau Central (25), Panneau Droit (26), Panneau Supérieur (28), Traverse Supérieur (35), Pied (36), Traverse Avant Inférieur (37) et Traverse Latérale Inférieur (39).

(ES)

Inserte las Espigas (A) en el Lado Derecho del Cajón (19), Lado Izquierdo del Cajón (20), el Panel Izquierdo (24), Panel Central (25), Panel Derecho (26), Panel Superior (28), Travesaño Superior (35), Pie (36), Travesaño Delantero Inferior (37) y Travesaño Lateral Inferior (39).

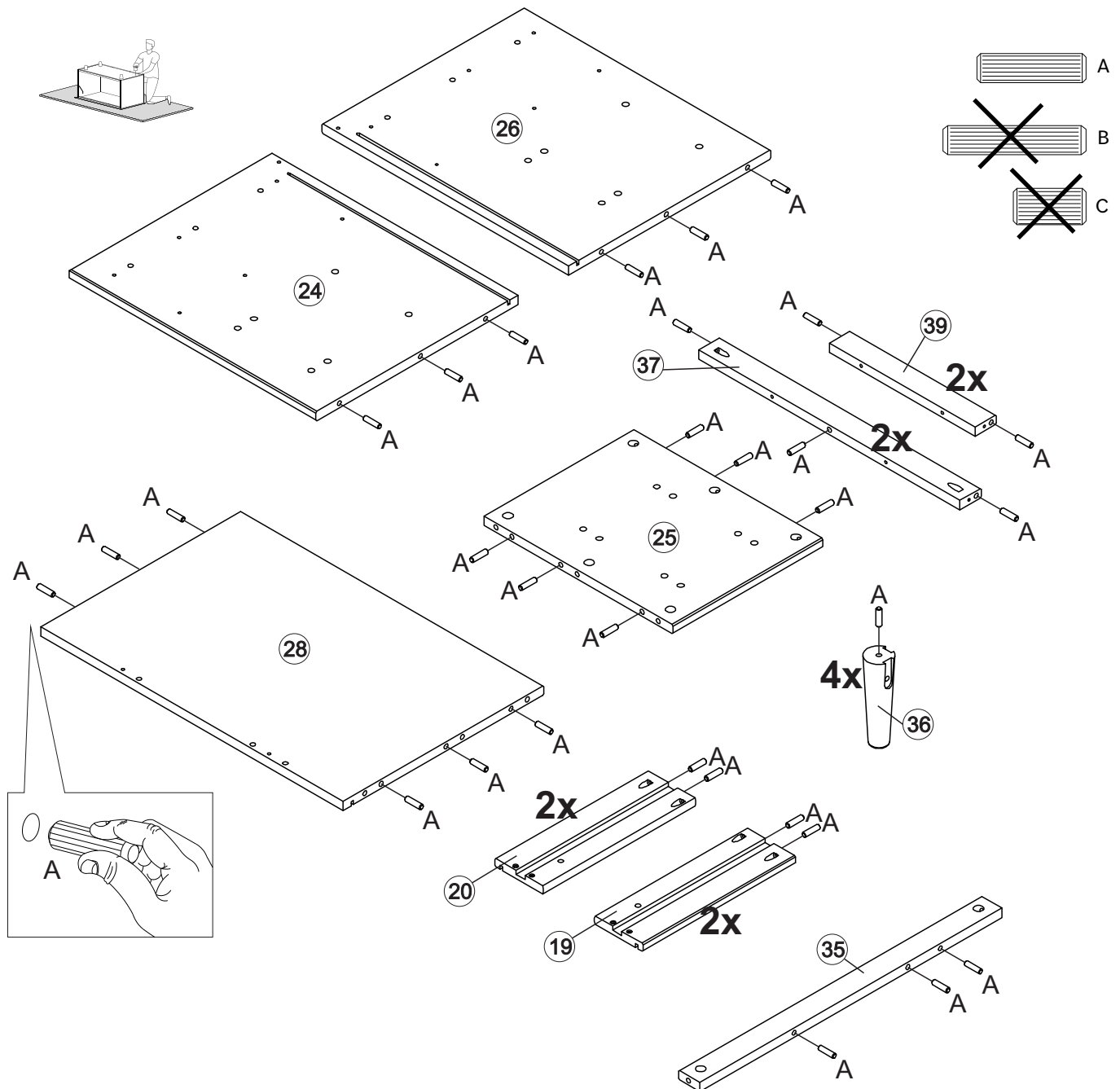

Tip
Pour que ton produit conserve son meilleur aspect et sans rayures, essaie de le monter sur une surface souple telle qu'un tapis ou une couverture. Cela permet d'éviter les rayures accidentelles et de garder tes meubles en bon état!

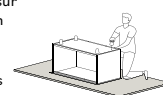

Para mantener su producto con el mejor aspecto y sin arañazos, pruebe a montarlo sobre una superficie blanda, como una alfombra o una manta. Así evitará arañazos accidentales y mantendrá sus muebles en perfecto estado.

Étape / Paso 3

(FR)

Fixez le Goujon de Assemblage (H), selon le schéma, sur le Panneau Gauche (24), Panneau Droit (26), l'Étagère (29) et le Panneau Inférieur (32) à l'aide d'un tournevis Phillips.

(ES)

Fije el Conector (H), según el diagrama, en el Panel Izquierdo (24), Panel Derecho (26), la Repisa (29) y el Panel Inferior (32) con un destornillador Phillips.

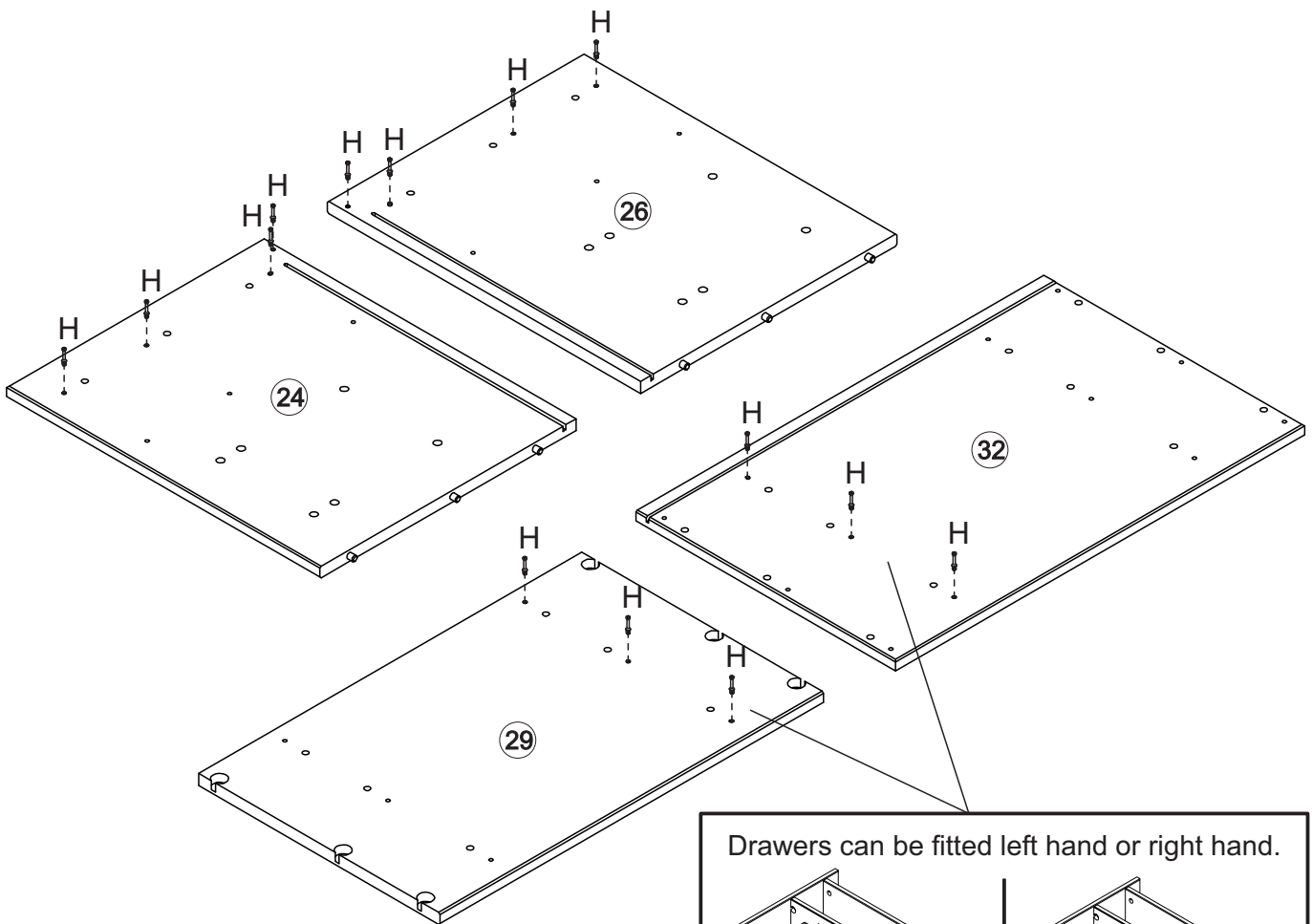
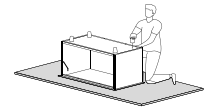

Drawers can be fitted left hand or right hand.

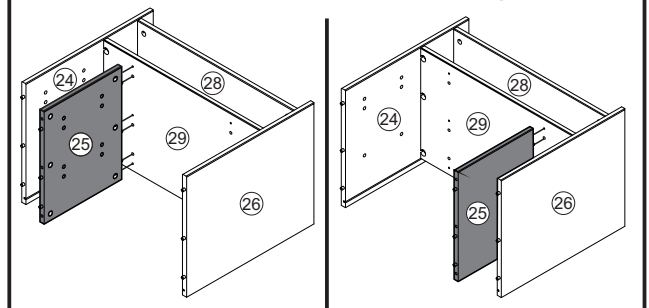

WARNING!

Assembly instruction shows drawers in the right side

Étape / Paso 4

(FR)
Faites de même avec les Boitier de Assemblage (K) sur le Panneau Gauche (24) et le Panneau Droit (26) à l'aide d'un tournevis phillips.

(ES)
Haga lo mismo con los Conectores (K) en el Panel Izquierdo (24) y el Panel Derecho (26) usando un destornillador Phillips.

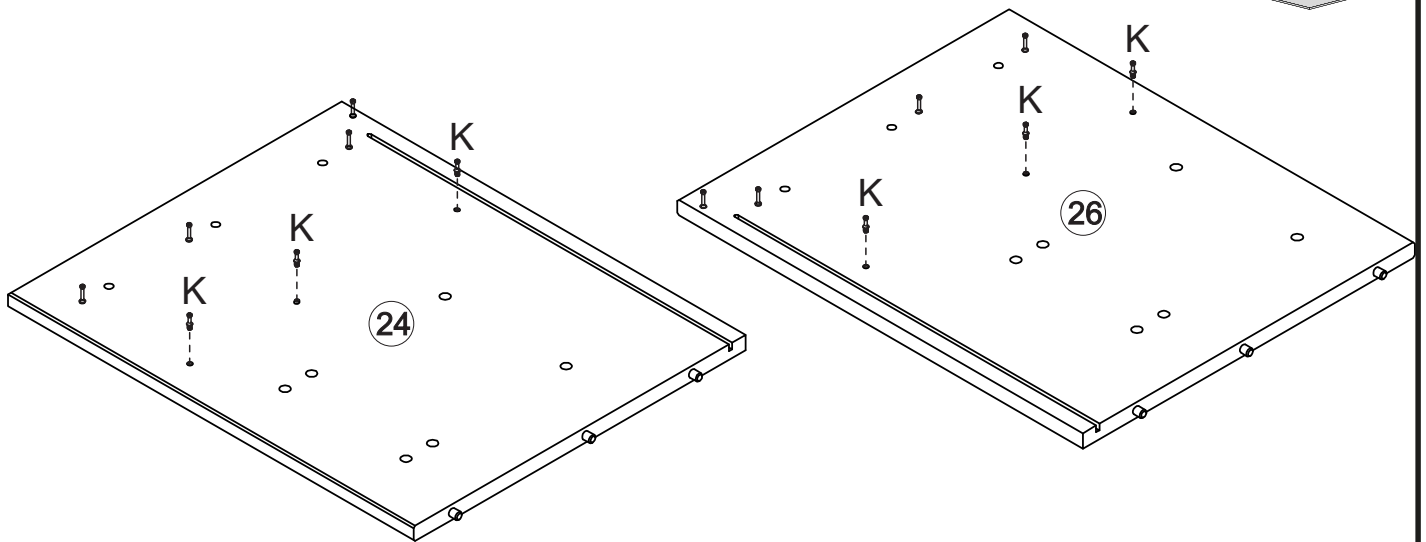

Étape / Paso 5

(FR)
Attacher Glissières en Bois (17) dans le Panneau Central (25) and Panneau Droit (26) utilisant Vis (E) et un tournevis Phillips.

(ES)
Fije las Correderas de Madera (17) a la división (25) y al panel lateral derecho (26) usando el tornillo (E) y un destornillador Phillips.

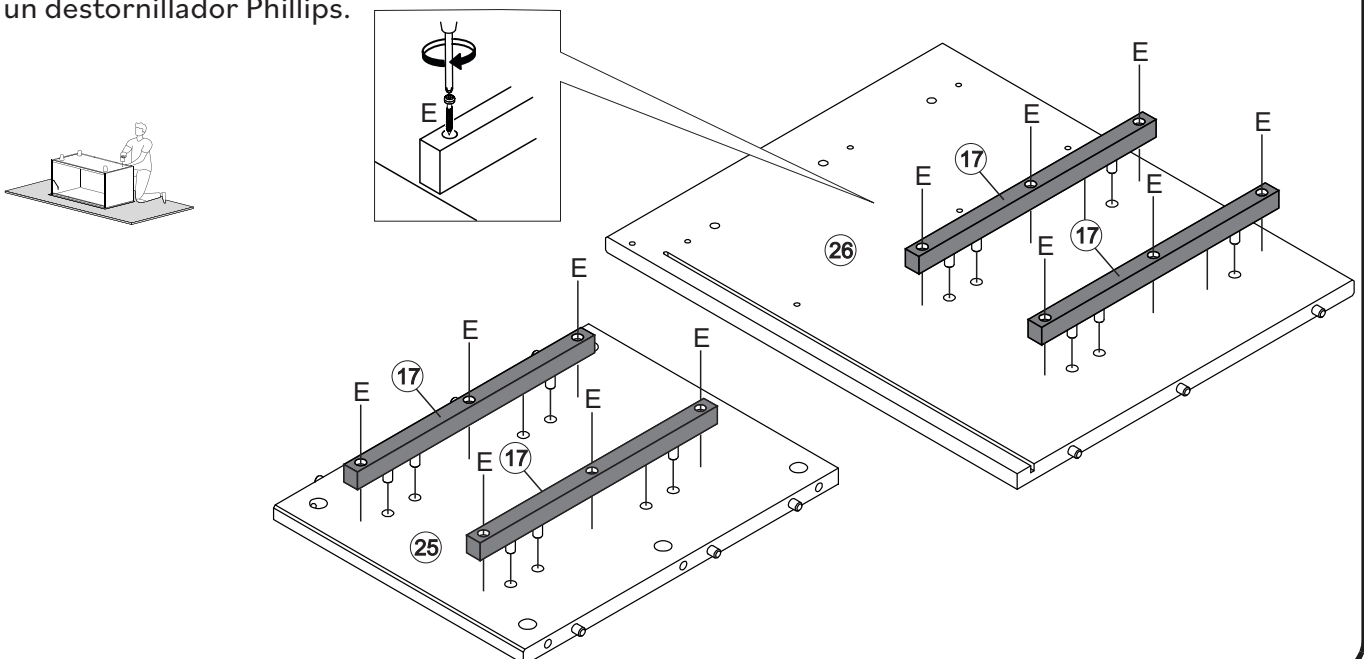

Étape / Paso 6

(FR) Fixez la Traverse Supérieure (35) au Panneau Supérieure (28) à l'aide de la vis (F) et d'un tournevis Phillips.

(ES) Fije el Travesaño Superior (35) al Panel Superior (28) usando el Tornillo (F) y un destornillador Phillips.

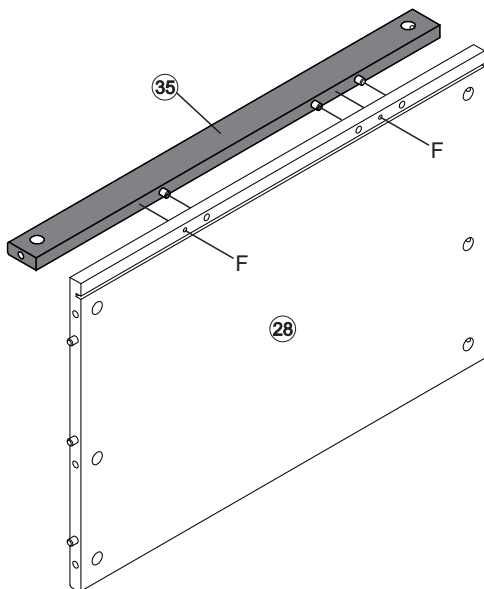

Étape / Paso 7

(FR) Assemblez le Panneau Gauche (24) et le Panneau Droit (26) sur le Panneau Supérieure (28) en installant les Goujons de Assemblage (H) et en fixant les Boitiers de Assemblage (I) à l'aide d'un tournevis cruciforme.

(ES) Ensamble el Panel Izquierdo (24) y el Panel Derecho (26) en el Panel Superior (28), colocando los Conectores (H) y fijando las Trabas del Conector (I) con un destornillador Phillips.

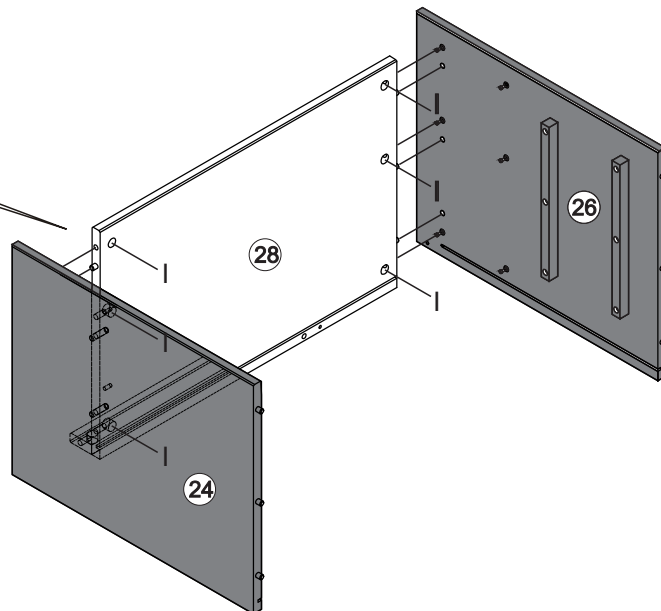
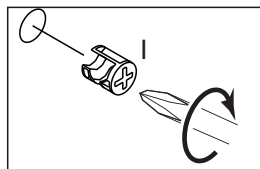
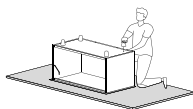

Tip

Mini Fix

Mini Fix permet de joindre deux pièces en toute sécurité. Suis ces étapes simples.

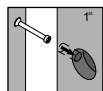

1: Insère le Mini Fix dans les orifices du côté plat. Ne serre pas trop !
1: Coloca el tornillo Mini Fix en los orifices del lado plano. No aprietes demasiado!

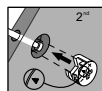

2: Joins les pièces en bois. Les vis Mini Fix entrent dans les orifices qui ont des trous sur les côtés, tu dois pouvoir voir les vis Mini Fix à travers ceux-ci. Après avoir installé les pièces, insère le tambour Mini Fix dans les orifices latéraux.
2: Une las piezas de madera. Los tornillos Mini Fix entran en las piezas que tienen orificios en los lados, por lo que deberías poder ver los tornillos Mini Fix a través de ellos. Después de encajar las piezas, inserta el tambor del tornillo Mini Fix en los orifices laterales.



3: Sur la partie arrière du tambour, il aura la forme d'un « C ». Insère le tambour de manière à ce que l'ouverture « C » s'emboîte à la vis Mini Fix. Serre-la avec le tournevis.
3: La parte posterior del tambor tendrá la forma de «C». Inserta el tambor de modo que la abertura de la «C» encaje en el tornillo Mini Fix. Aprétalo con un destornillador.

Étape / Paso 8

(FR) Insérez le Verrou en Plastique (L) dans l'Étagère (29) à l'aide d'un marteau si nécessaire.

(ES) Inserte la Traba Plastica (L) en la Repisa (29) usando un martillo si es necesario.

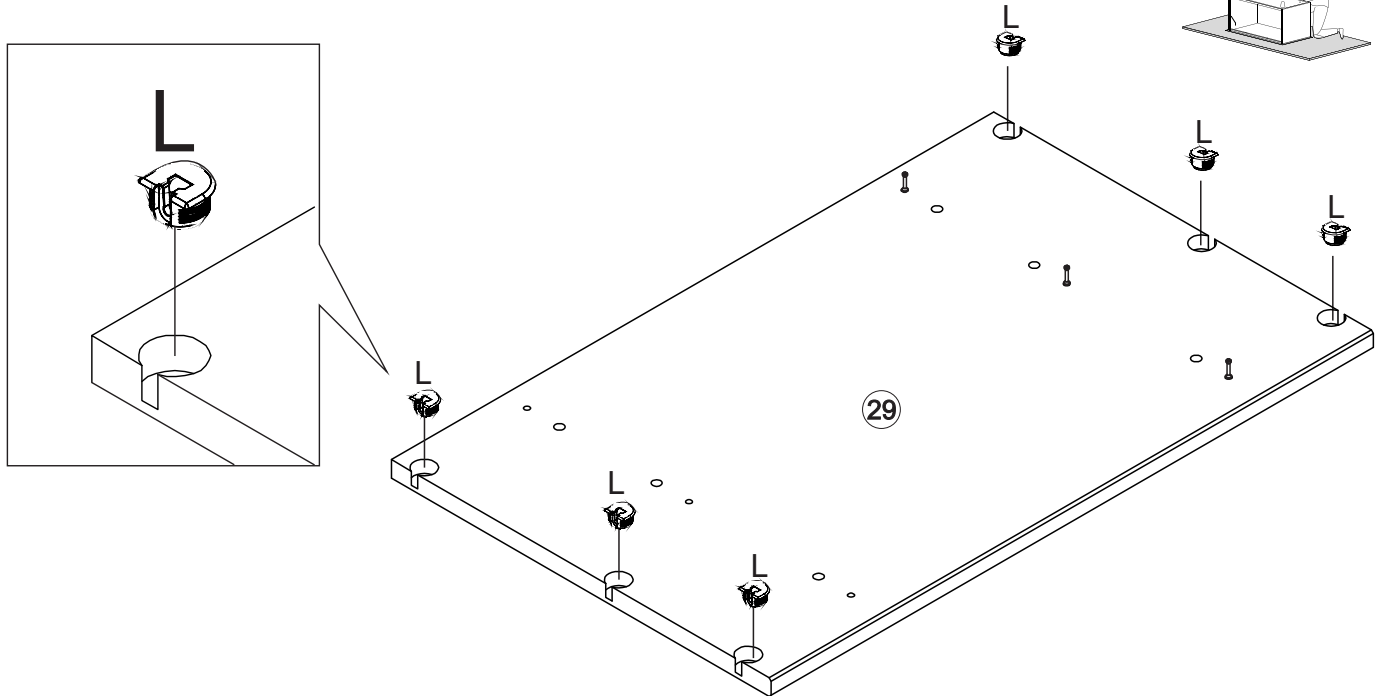

Étape / Paso 9

(FR) Fixez le Panneau Central (25) à l'Étagère (29) à l'aide du Boitiers de Assemblage (I) et d'un tournevis Phillips.

(ES) Asegure el Panel Central (25) a la Repisa (29) usando la Traba del Conector (I) y un destornillador Phillips.

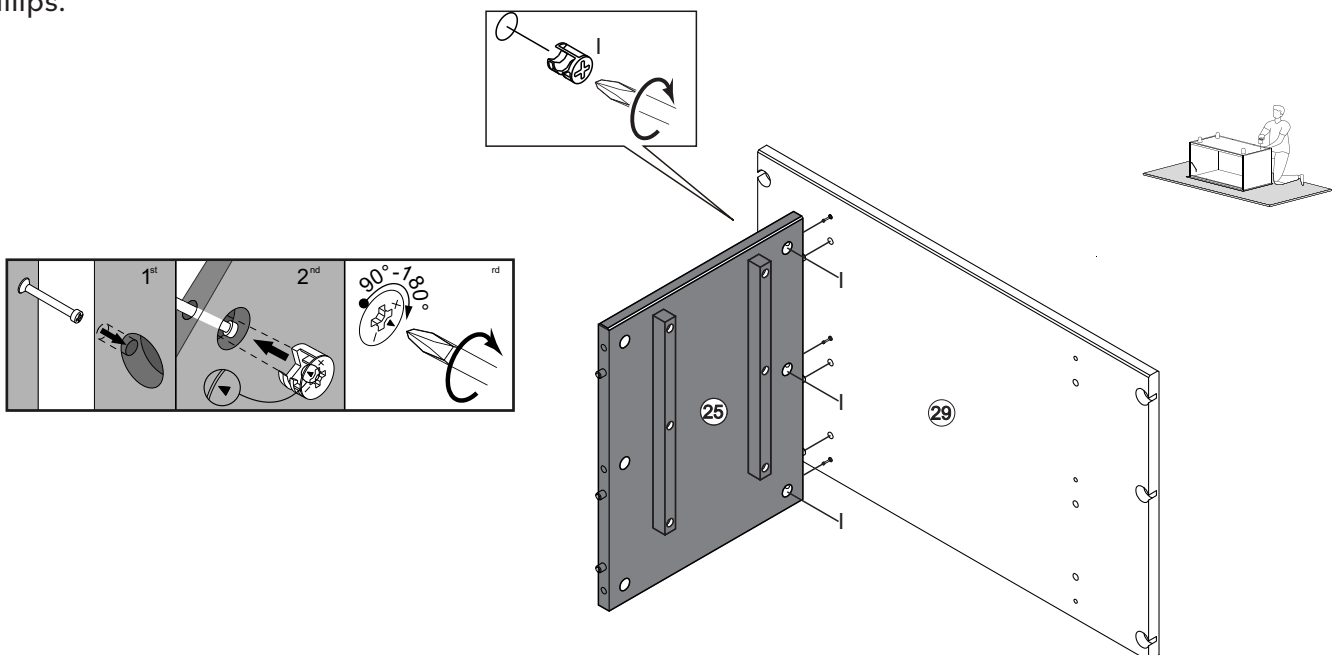

Étape / Paso 10

(FR)
Placez la Panneau Central (25) et l'Étagère (29) sur les broches. Alignez les broches du Panneau Gauche (24) et du Panneau Droit (26) à l'intérieur du Verrou en Plastique (L).

(ES)
Coloque el Panel Central (25) y la Repisa (29) sobre los pasadores. Alinee los pasadores del Panel Izquierdo (24) y del Panel Derecho (26) dentro de la Traba Plastica (L).

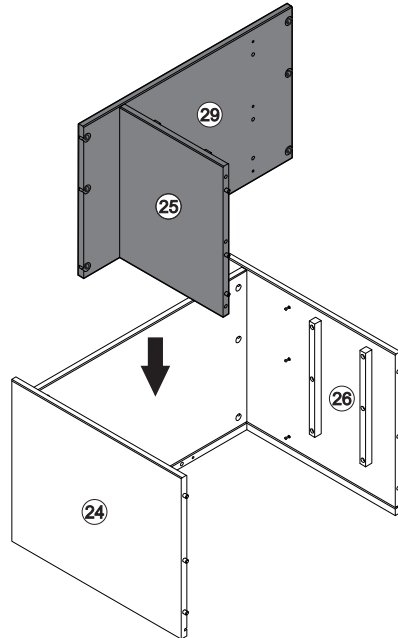

Étape / Paso 11

(FR)
Appuyez jusqu'à ce que vous sentiez l'ajustement ou "clic".

(ES)
Presione hasta que sienta el ajuste o haga "clic"

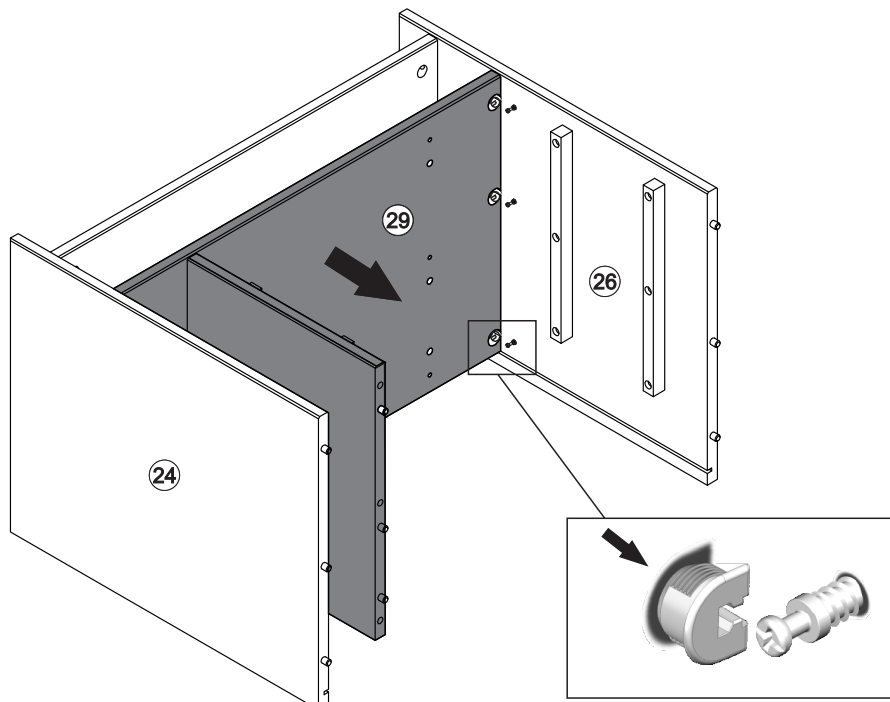

Étape / Paso 12

(FR)
Faites glisser le Panneau Arrière (30) sur les rainures du Panneau Gauche (24) et du Panneau Droit (26). Fixez ensuite le Panneau Inférieur (32) à l'aide de la vis (G) et d'un tournevis Phillips.

(ES)
Deslice el Panel Trasero (30) en las ranuras del Panel Izquierdo (24) y del Panel Derecho (26). Luego fije el Panel Inferior (32) usando el Tornillo (G) y un destornillador Phillips.

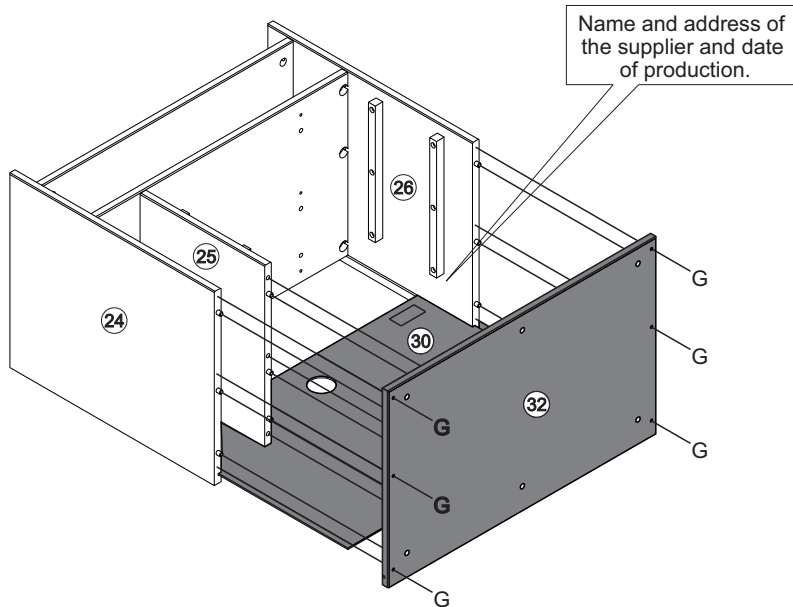

Étape / Paso 13

(FR)
Fixez le Panneau Inférieur (32) à le Panneau Central (25) en fixant le Boitiers de Assemblage (I) à l'aide d'un tournevis Phillips.

(ES)
Asegure el Panel Inferior (32) al Panel Central (25) fijando la Traba del Conector (I) con un destornillador Phillips.

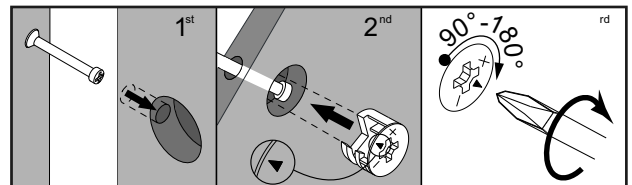
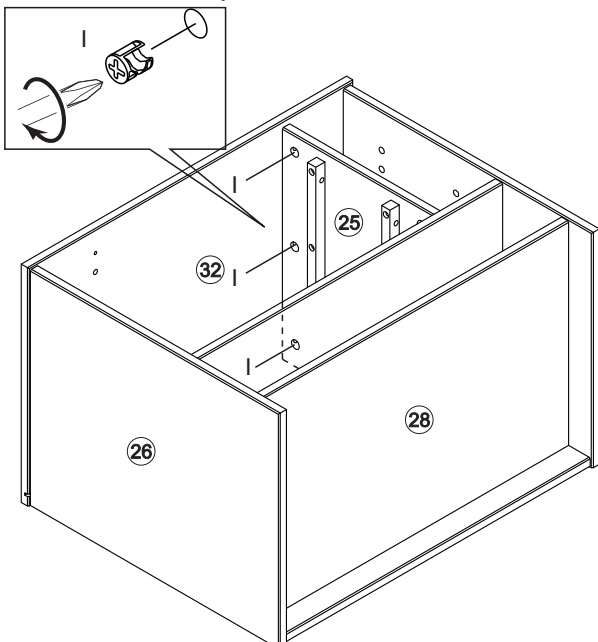

Étape / Paso 14

(FR)

Fixez la Traverse Avant Inférieure (37) au Pied (36) à l'aide de la Vis (G) à l'aide d'un tournevis Phillips.

(ES)

Asegure el Travesaño Delantero Inferior (37) al Pie (36) usando el Tornillo (G) y un destornillador Phillips.

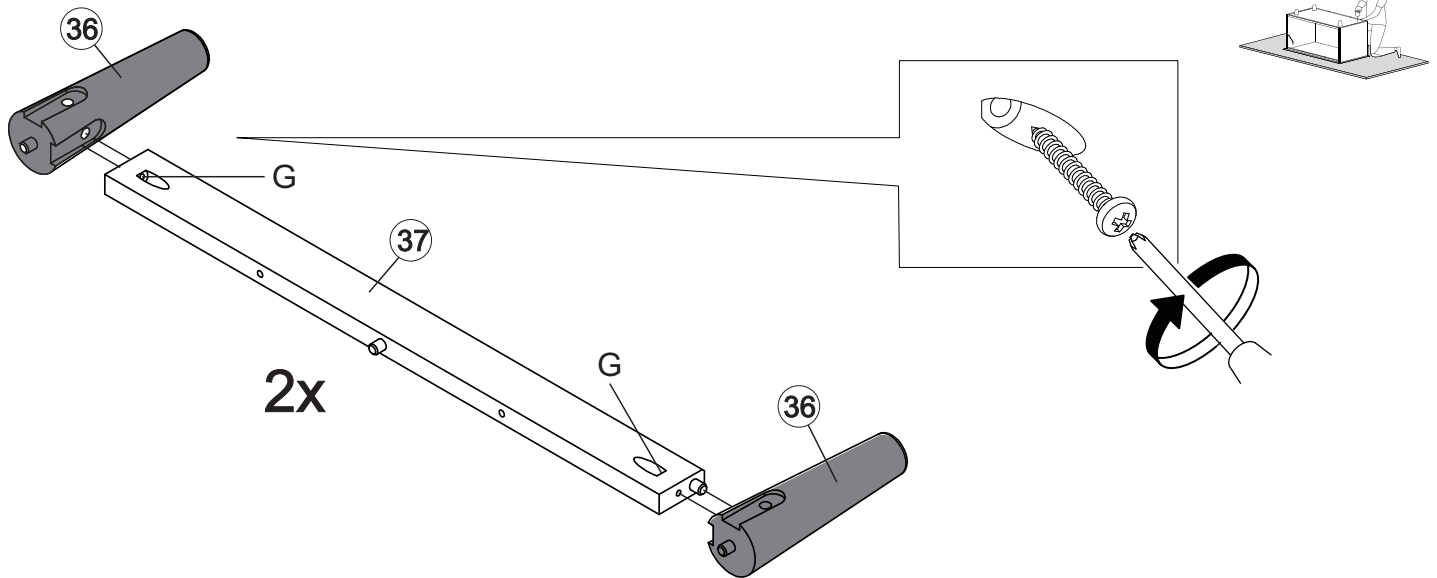

Étape / Paso 15

(FR)

Fixez la Traverse Latérale Inférieure (39) au Pied (36) avec la Vis (G) à l'aide d'un tournevis Phillips.

(ES)

Fije el Travesaño Lateral Inferior (39) al Pie (36) con el Tornillo (G) usando un destornillador Phillips.

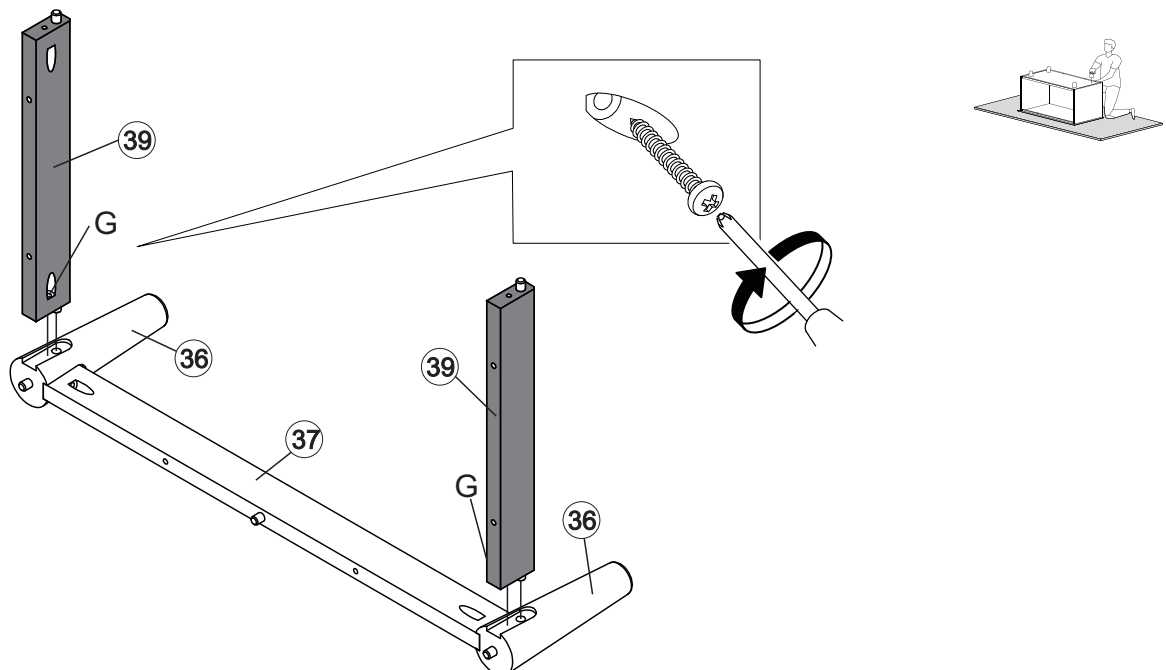

Étape / Paso 16

(FR) Pour terminer l'assemblage des pieds, fixez la Traverse Latérale Inférieure (39) au Pied (36) avec la Vis (G) à l'aide d'un tournevis phillips.

(ES) Para terminar de ensamblar los pies, fije el Travesaño Lateral Inferior (39) al Pie (36) con un Tornillo (G) y un destornillador Phillips.

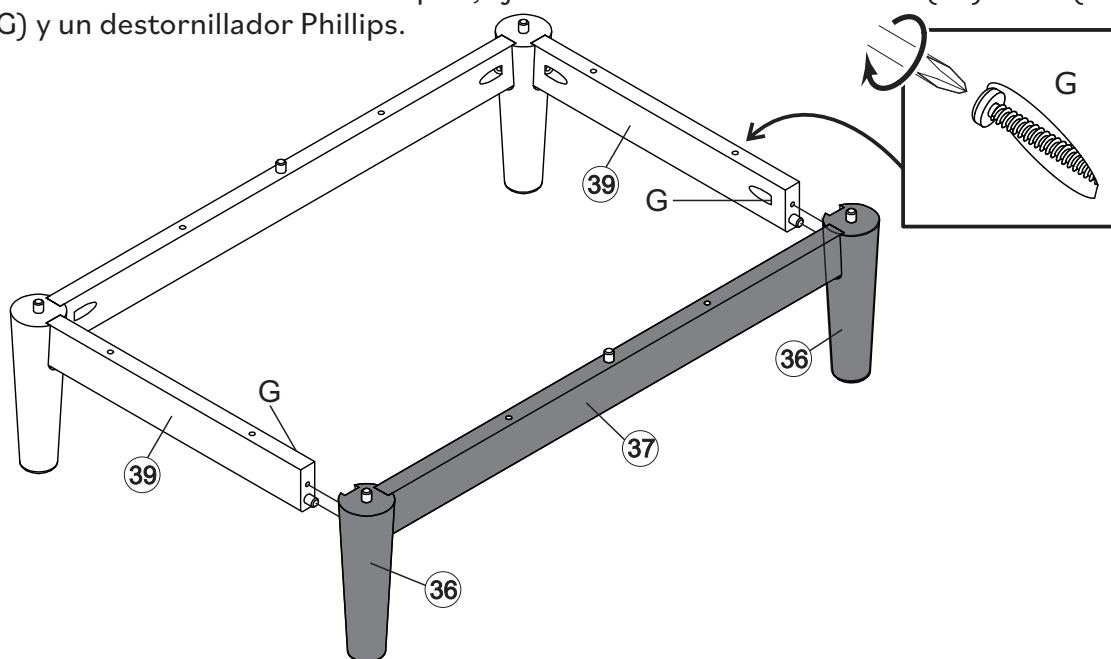

Étape / Paso 17

(FR) Maintenant, fixez les pieds assemblés au Panneau Inférieure (32) avec la Vis (G) à l'aide d'un tournevis Phillips.

(ES) Ahora, fije los pies ensamblados al Panel Inferior (32) con el Tornillo (G) y un destornillador Phillips.

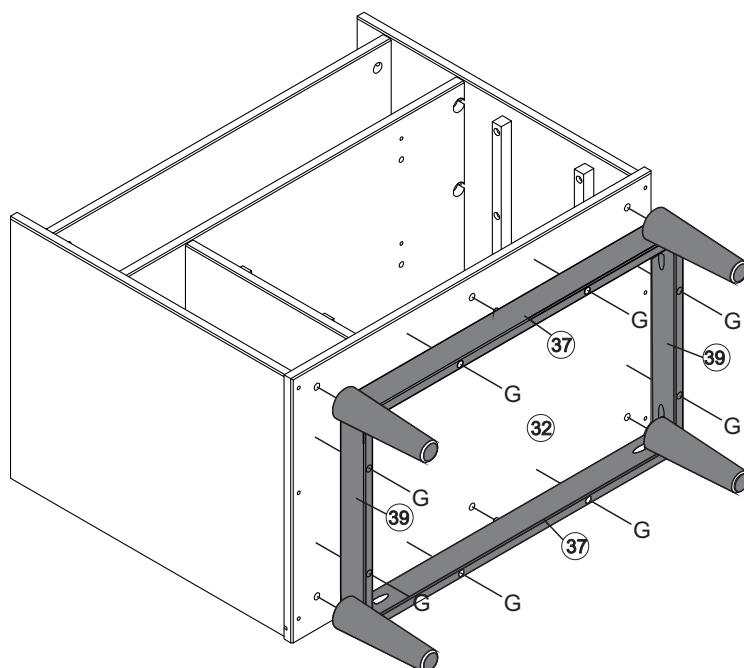

Étape / Paso 18

(FR)
Insère les Chevilles (A) dans les Glissières en Bois (17).

(ES)
Inserte las Espigas (A) en las Correderas de Madera (17).

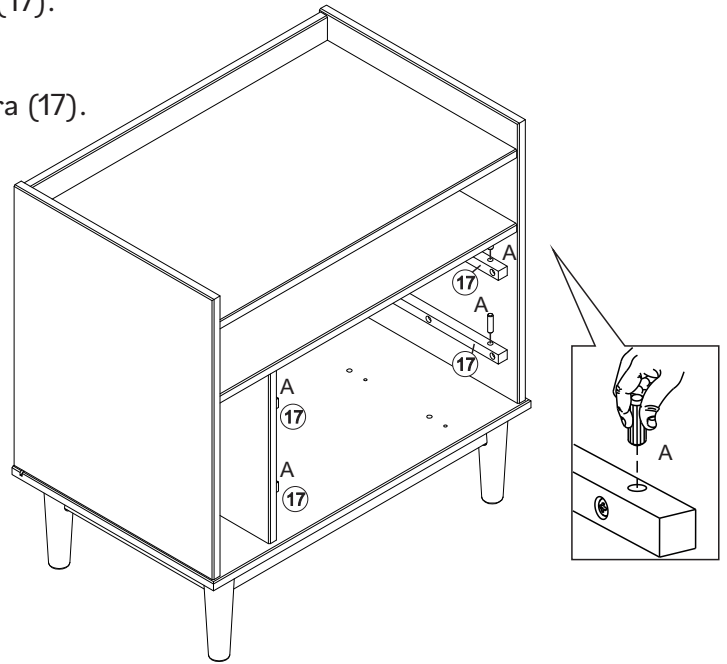
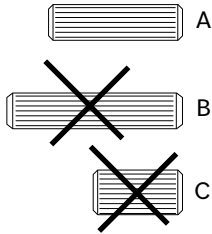

Étape / Paso 19

(FR)
Attacher Panneau Droit (19) et Panneau Gauche (20) à l'Façade du Tiroit (6) avec la Vis (F) à l'aide d'un tournevis Phillips. Faites glisser le Fond du Tiroir (23) sur les rainures des Côtés Droit et Gauche du Tiroir (19,20) en s'adaptant à la Façade du Tiroir (06). Fixez l'Arrière du Tiroir (21) aux Côtés Droit et Gauche du Tiroir (19, 20) à l'aide des Vis (D) et d'un tournevis Phillips.

(ES)
Fije el Panel Derecho (19) y el Panel Izquierdo (20) al Frente del Cajón (06) con un Tornillo (F) y un destornillador Phillips. Deslice la Parte Inferior del Cajón (23) en las ranuras de los Lados Derecho e Izquierdo del Cajón (19,20) que encajan en el Frente del Cajón (06). Fije la Parte Posterior del Cajón (21) al Lado Derecho e Izquierdo del Cajón (19,20) usando Tornillos (D) y un destornillador Phillips.

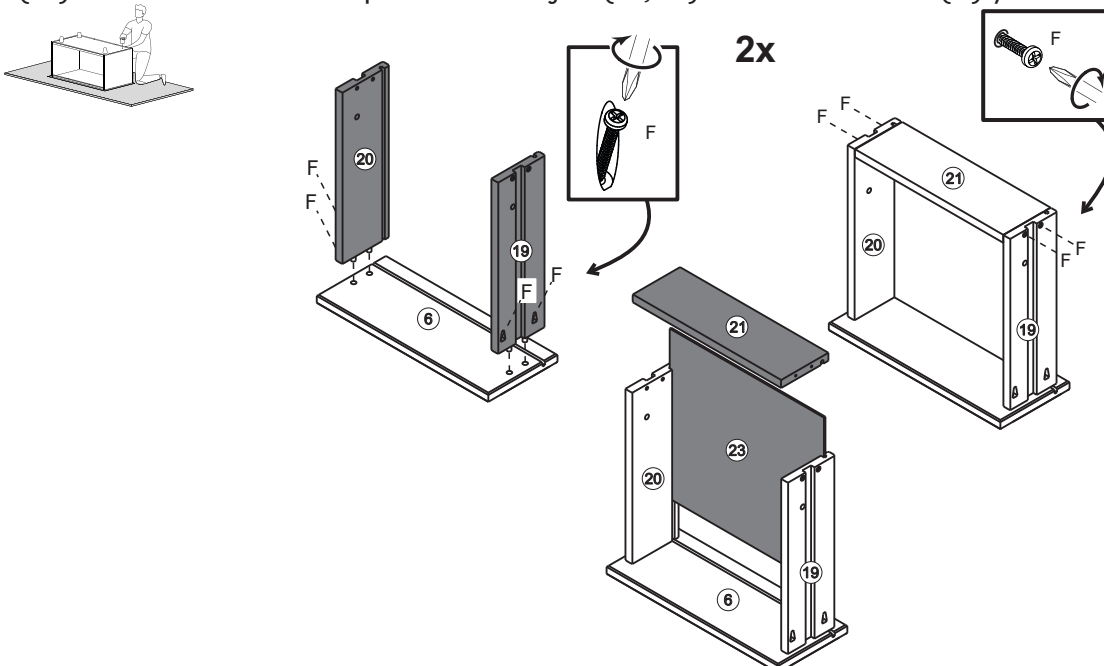

Étape / Paso 20

(FR)
Fixez la Poignée (J) avec la Vis (D) à l'aide d'un tournevis Phillips dans les trous pré-percés sur la Façade du Tiroir (06).

(ES)
Asegure la Manija (J) con el Tornillo (D) usando un destornillador Phillips en los orificios previamente perforados en el Frente del Cajón (06).

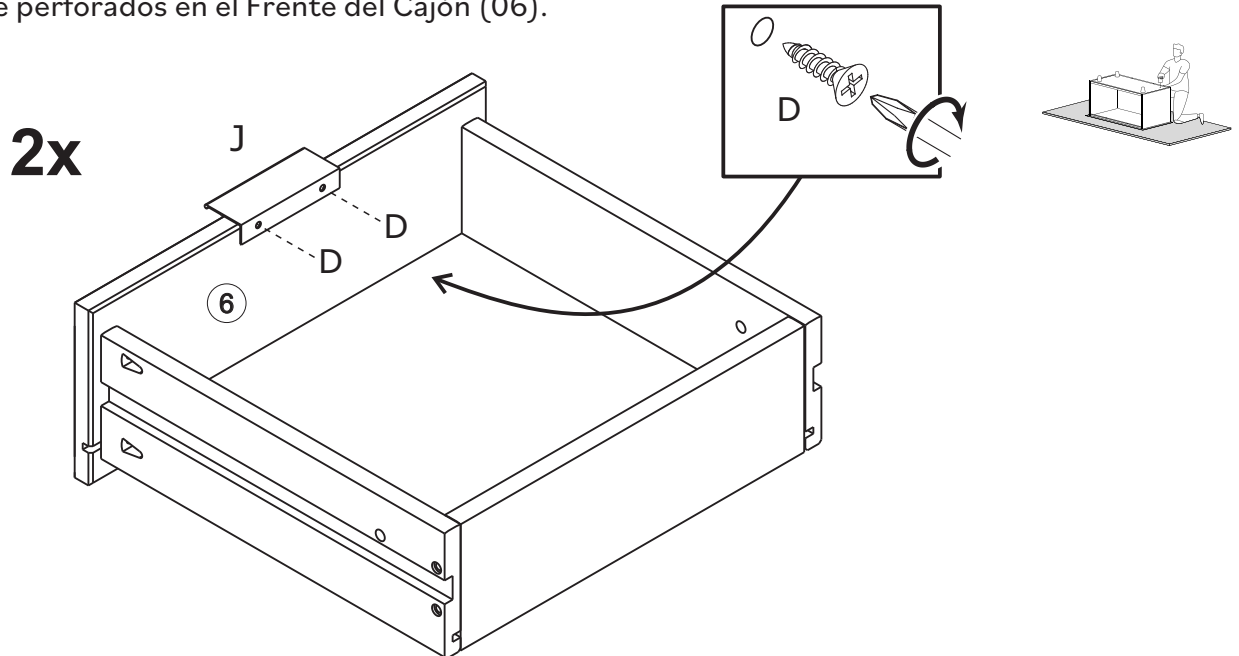

Étape / Paso 21

(FR)
Insérer la Cheville(B) à l'intérieur de tous les tiroirs, avec le tiroir à l'intérieur de l'unité, après avoir passé la cheville qui se trouve dans la glissière du tiroir. La cheville n'est pas à fleur du panneau, elle se trouve un peu à l'intérieur du tiroir pour vous aider lorsque vous devez retirer la cheville de verrouillage pour retirer le tiroir.

(ES)
Inserte la Espiga (B) en el interior de todos los cajones, con el cajón dentro de la unidad, después de haber pasado la espiga que se encuentra en la corredera del cajón. La clavija no está al ras con el panel, está un poco dentro del cajón para ayudar cuando necesite quitar la espiga de bloqueo para quitar el cajón.

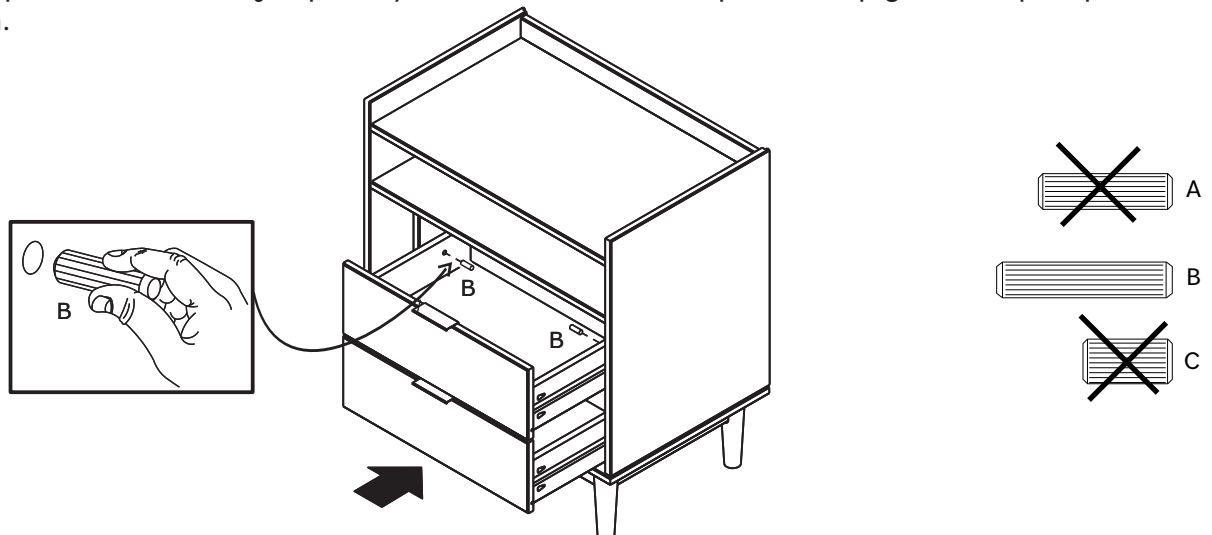

Étape / Paso 22

FR
Insérez le cache-trou (M) dans la niche.

ES
Inserte el Tapa agujero (M) en el nicho.

Il existe des options de couleurs pour les cache-trou, choisissez le cache-trou en fonction du meuble

Hay opciones de colores para los tapa agujeros, elige los tapa agujeros según el color del mueble

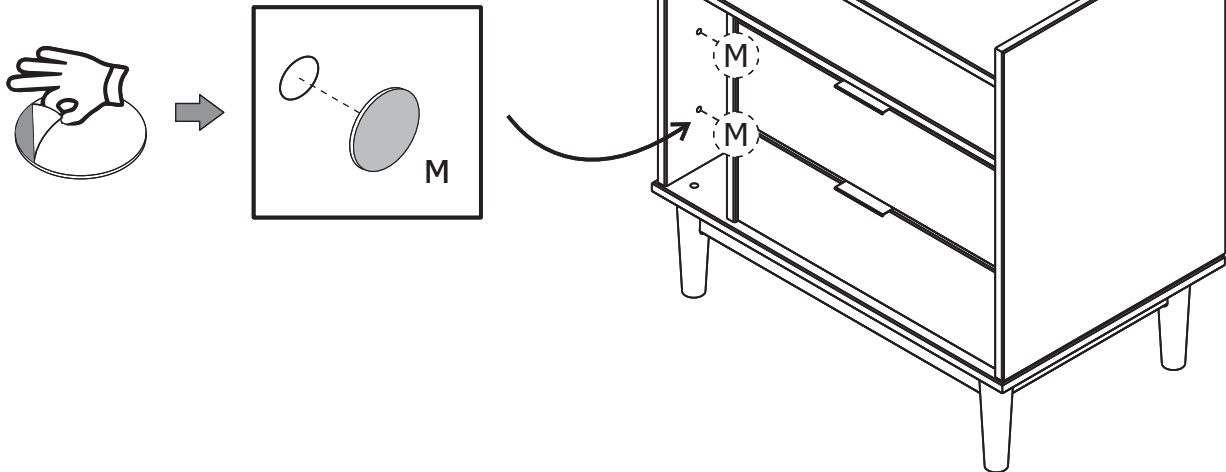

Étape / Paso 23

(FR)
Fixez la Traverse Supérieure (35) au Panneau Gauche (24) et au Panneau Droit (26) avec un Boitiers de Assemblage (I) à l'aide d'un tournevis cruciforme.

(ES)
Fije el Travesaño Superior (35) al Panel Izquierdo (24) y al Panel Derecho (26) con la Traba de Conector (I) usando un destornillador Phillips.

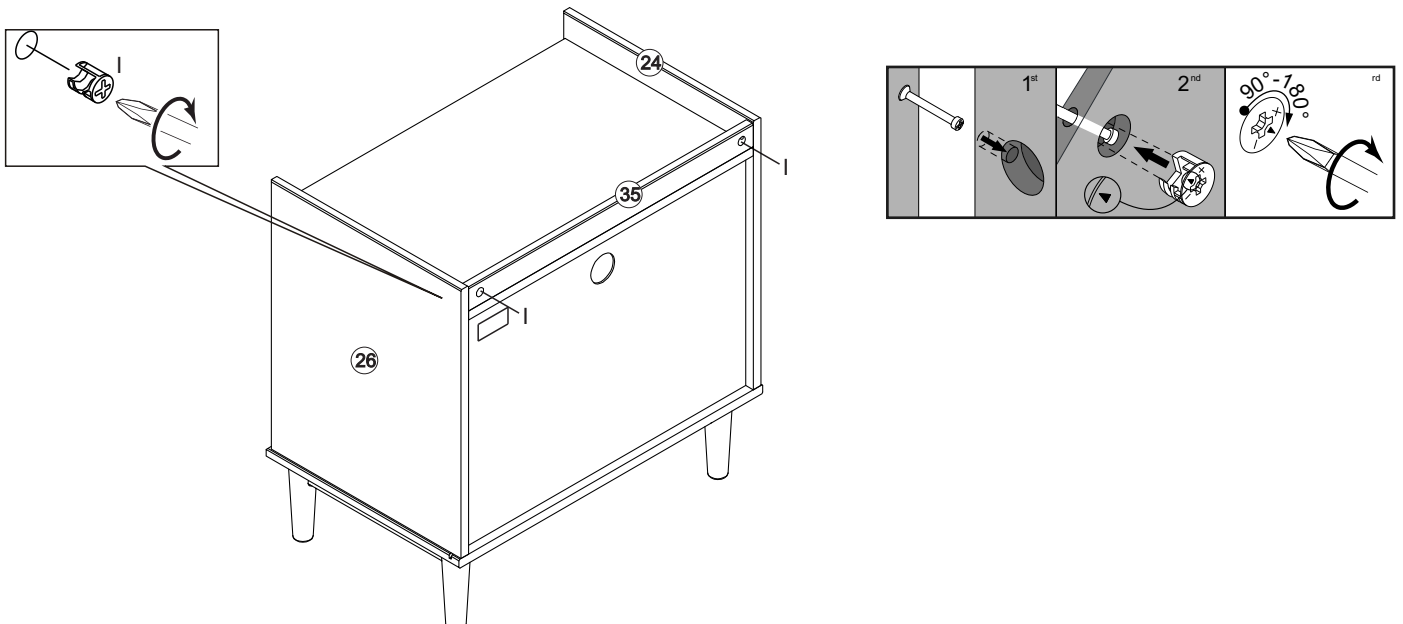

Tu as réussi ! Profite de ton nouveau Table de Chevet!
¡Lo ha conseguido! ¡Disfrute de su nueva Mesita de Noche

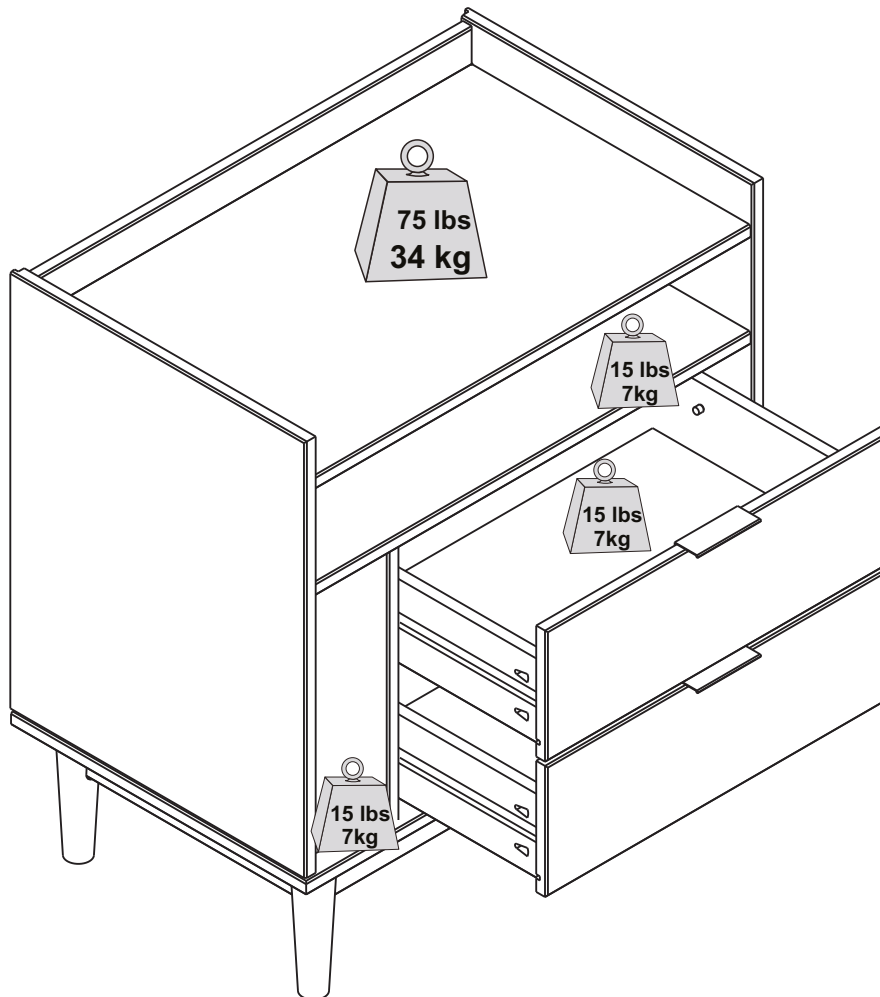

Bravo pour ton nouveau meuble !

Nous aimerions t'en entendre parler et le voir.

S'il te plait, laisse-nous un commentaire ou publie une photo sur

#mywalkeredisonhome

¡Enhorabuena por sus nuevos muebles!

Nos encantaría oírlo y verlo.

Por favor, déjenos un comentario o publique una foto con

#mywalkeredisonhome

Assembler des meubles peut parfois être compliqué.

Notre équipe de service client, située dans l'Utah, est là pour obtenir des informations sur les produits, aider pour l'assemblage d'un produit ou pour tout autre problème de support client.

Appelle-nous **801-433-3008**

Envoie-nous les e-mails à service@walkeredison.com

walkeredison.com/pages/customer-service

Nous sommes disponibles pour t'aider du Lundi au Jeudi de 8 am - 5 pm, Vendredi de 8 am - 3 pm MST.

Pour plus de détails sur les vidéos d'assemblage, les instructions d'assemblage, les pièces de rechange et le service client.

NUMÉRISER ICI.



Pour le nettoyage, n'utilise jamais d'abrasifs, utilise un chiffon doux et de l'eau avec du savon neutre pour nettoyer les meubles.

A veces, montar muebles puede resultar complicado.

Nuestro equipo de atención al cliente, ubicado en Utah, está a su disposición para informarle sobre los productos, ayudarle a montarlos o resolver cualquier otro problema de atención al cliente.

Llámenos **801-433-3008**

Envíenos un correo electrónico a service@walkeredison.com

Visite nuestra página web de atención al cliente

walkeredison.com/pages/customer-service

Estamos a su disposición para ayudarle de lunes a jueves de 8:00 a 17:00, viernes de 8:00 a 15:00 MST.

Para más detalles sobre videos de montaje, instrucciones de montaje, piezas de recambio y servicio de atención al cliente

ESCANEE AQUÍ



Para la limpieza, nunca utilice productos abrasivos, utilice un paño suave y agua con jabón neutro para limpiar los muebles.