

IN40022CH

MAE 3-LIGHT WALL SCONCE

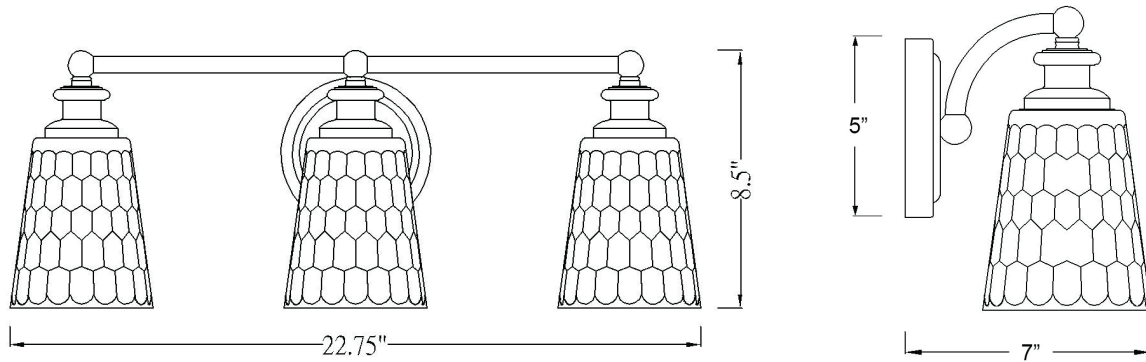

Description:	Mae 3-Light Wall Sconce
Finish:	Chrome
Dimensions:	22-3/4" W x 8-1/2" H x 7" ext. Height on Center: 5"
Bulbs:	3-100W Med.
Installed Weight:	5.25 lbs.
Certification:	cUL / damp location

Material:	Steel and glass
Shades:	Glass
Glass:	Clear Optic
Back Plate Dimensions:	5" Dia.
Chain/Wire:	NA
Additional Finishes:	Oil-rubbed bronze and matte black